

Jabot Template System Instructions



Updated on 2/18/08

INTRODUCTION

Cascades and jabots, together with swags, lend beauty, style, and elegance to window treatments. The Jabot Template System will help you to center fabric motifs, mark the fabric, and enable you to pleat jabots quickly and evenly. The Jabot Template System consists of:

1. A clear Jabot Template
2. Two Jabot Pleating Tapes

Terms:

“Jabots,” “cascades,” “tails,” “ascots,” and many other terms have been used to refer to this type of treatment. The Jabot Template System and instructions use the term “jabot” to describe the treatments in Fig. A, and “double jabot” for the treatment shown in Fig. B. We will use these terms throughout our instructions to eliminate any confusion.

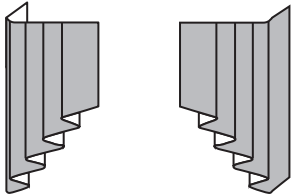

Fig. A Left Jabot and Right Jabot

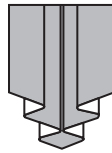

Fig. B Double Jabot

Seam Allowance:

The user does not have to add a seam allowance since the Jabot Template System includes a $\frac{1}{2}$ " seam. For mounting purposes, the template adds an extra 1" to the top of the jabot to go over the board. Adjust accordingly, if more or less fabric is needed to go over the board.

JABOT: Step-by-Step

Example:

The jabot example explained in the following instructions has a 13" finished width, with four pleats, 4" return, 18" short point and 38" long point.

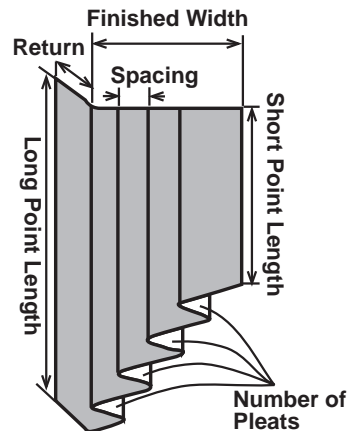

Step 1-Measurements

- Determine jabot's:
 1. Finished width
 2. Number of pleats
 3. Long point length
 4. Short point length
 5. Return

Step 2-Position Template

- Stack the face fabric and lining, **right** sides together.
- If work on the **right** jabot, have the face fabric on top, if work on the **left** jabot, have the lining on top.
- Lay the clear Jabot Template on the fabric. If necessary, reposition the template to center the motif.
- On the template, find the desired number of pleats and the finished width. Make a note of, as shown below on the Post Note:
 1. The color of the width number
 2. The letter following the width number
- Along the top edge of the template, draw a straight line from the desired return to the desired jabot finished width (See below).

1. Start at the arrow marked with the desired return (e.g. 4").
2. Draw a straight line along this edge.
3. End at the arrow marked with the desired jabot width (e.g. 13").

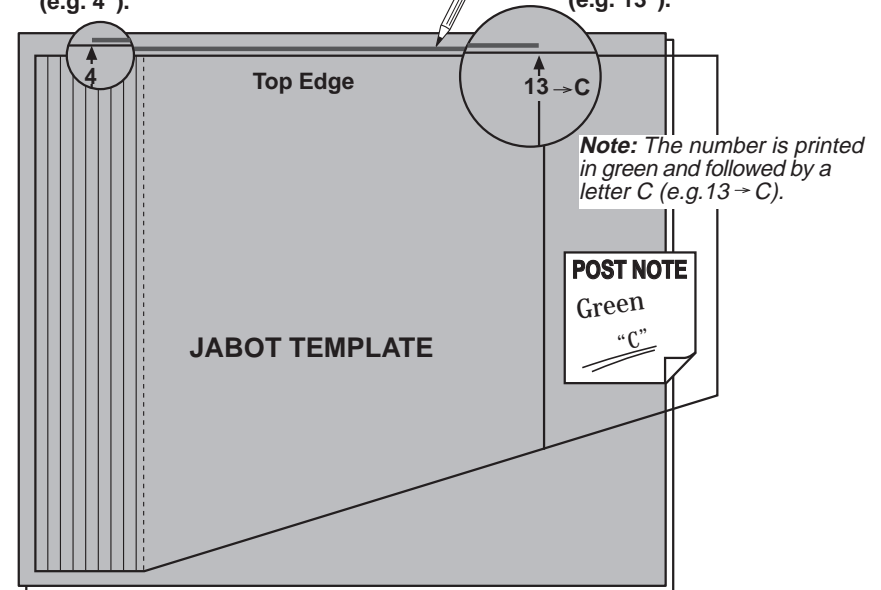

Step 3-Mark Fabric

- Along the straight line marked with the desired jabot finished width, find the desired short point and mark (See 1. below).
- Find the desired jabot long point along the dashed line on the return side of the template. Draw a straight line from the dashed line to the desired jabot return (See 2. below).

Note: If the jabot's long or short point measurements are longer than the markings provided on the template, use a straight edge to extend the lines.

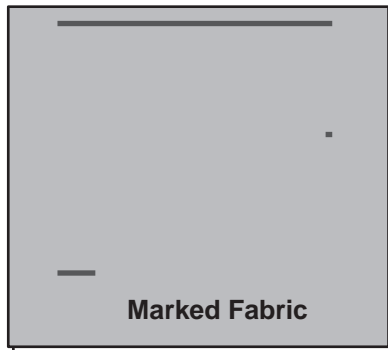
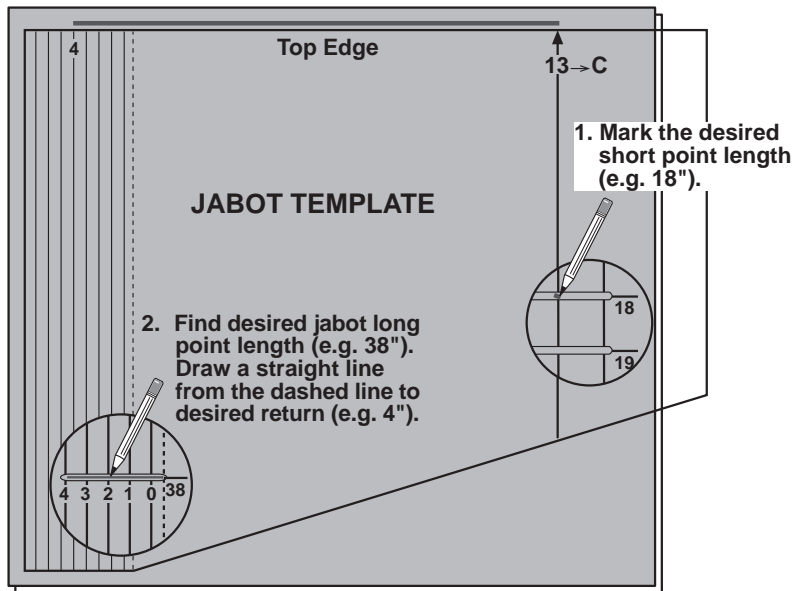

Step 4-Draw Jabot Pattern

- Remove the template. Using a straight edge, draw straight lines to connect the marks.

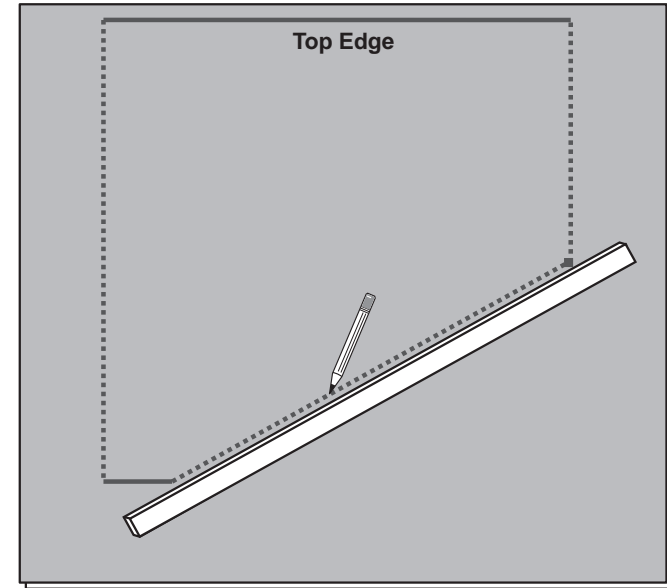

Note: If the jabot has a contrast band, refer to page 10 for instructions.

Step 5-Sew Jabot

- Cut the face fabric and lining. If using interlining, cut interlining as well.
- With right sides together and using a 1/2" seam allowance, stitch the face fabric and lining together along all edges except top.
- Trim the corners. Turn right side out and press.

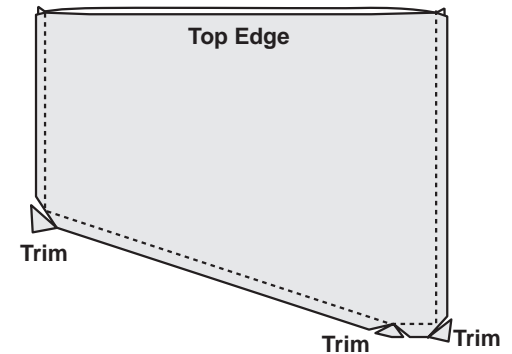

Step 6-Position and Pin Jabot Pleating Tapes

- Lay the jabot sideways on the worktable with the face fabric up, as shown.
- Place the first Jabot Pleating Tape on the jabot along the top edge. If the return is 4" (as in this example), align the return edge of the jabot with the 4" mark on the Jabot Pleating Tape (See below). Place the second tape parallel to the first tape and near the short point. Make sure that both Jabot Pleating Tapes lay straight and smooth.
- Pay attention **ONLY** to the portion of the Jabot Pleating Tape with the color that matches the color of the width number noted in Step 2. (For the example used here: to make a jabot with a 13" finished width with four pleats, refer **ONLY** to the green portion of the Jabot Pleating Tape.)
- Pin the tapes to the jabot at each pair of matching color dots. Make sure the pins catch **BOTH** the face fabric **AND** the lining.

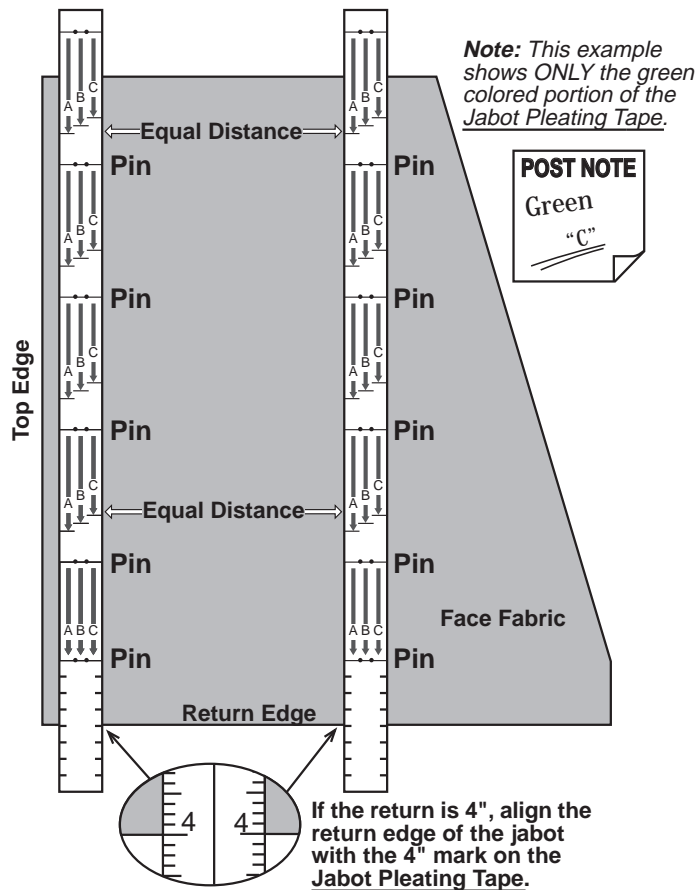

Step 7-Fold Jabot

- Skip the first pair of pins closest to the return edge, pick up the Jabot Pleating Tapes and jabot by each pair of pins. Follow the arrows with the appropriate color and letter, fold over in the arrow direction to align the pins with the horizontal lines pointed by those arrows.
- Pin the fabric to secure the pleat, as shown.
- Repeat folding and pinning at each pair of pins. This forms the evenly placed pleats.

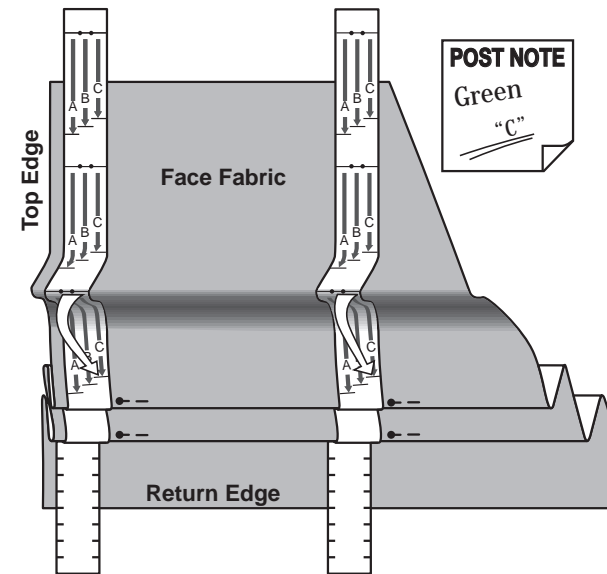

Step 8-Secure Pleats

- Leave the pins set in step 7 in place. Remove the pins from both Jabot Pleating Tapes. Remove both Jabot Pleating Tapes.
- Stitch along the top edge of the jabot to secure the pleats. Remove all the pins.
- To mount, refer to page 10.

DOUBLE JABOT: Step-by-Step

A double jabot, like the one illustrated here, may be looked at as a left and a right jabot joined together along the center. The steps in making double jabots are very similar to making regular jabots.

Example:

The double jabot example explained in the following instructions has a total finished width of 12" (finished half width of 6"), with two pleats on each half width. The short point length is 12" and the long point length is 18".

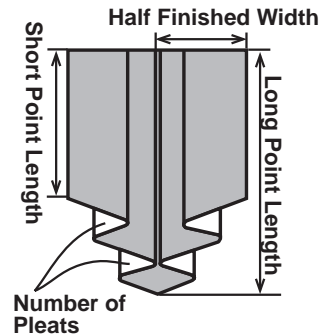

Step 1-Measurements

- Determine jabot's:
 1. Half finished width
 2. Number of pleats on each half width
 3. Long point length
 4. Short point length

Step 2-Position Template

- Stack the face and lining fabrics with **right sides together**.
- Fold the fabrics, as shown below.
- Place the clear Jabot Template on the fabrics. Make sure the fabric folded edge aligns with the dashed line labeled for double jabot on the Jabot Template, as shown.
- On the template, find the desired number of pleats and the half finished width. Make a note of, as shown below on the Post Note:
 1. The color of the width number
 2. The letter following the width number
- Along the top edge of the template, draw a straight line from the fabric folded edge to the desired jabot finished half width.

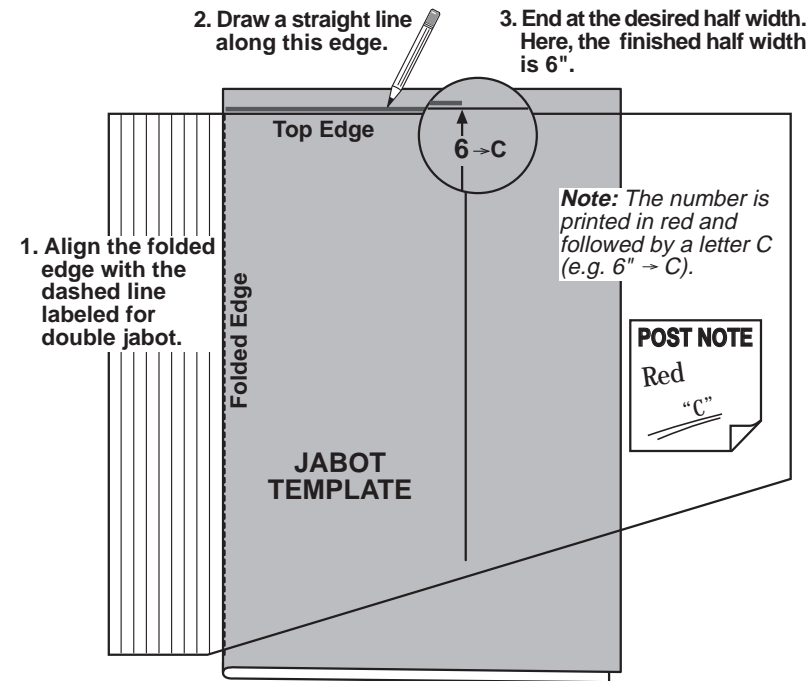

Step 3-Mark Fabric

- Along the straight line marked with the desired finished half width, find the desired short point length and mark (See 1. below).
- Find the desired long point length along the dashed line and mark (See 2. below).

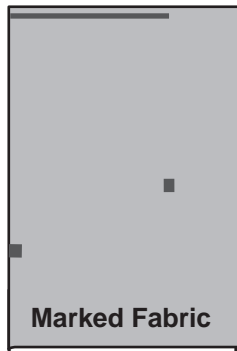
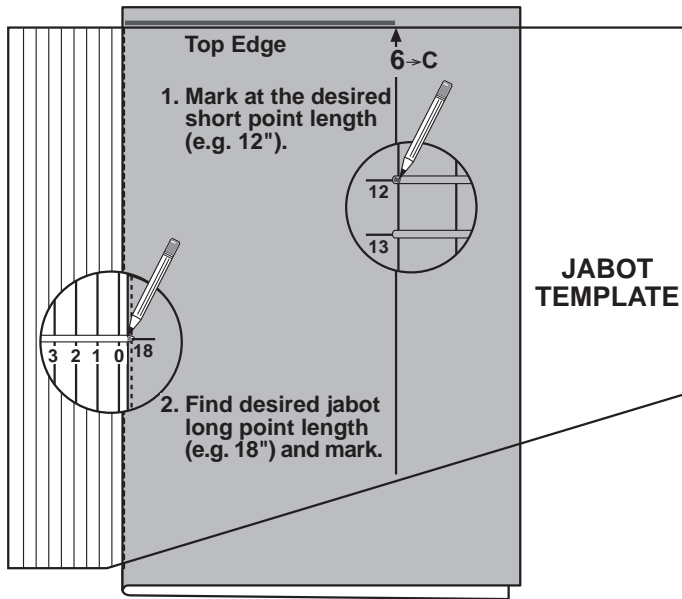

Step 4-Draw Double Jabot Pattern

- Remove the template. Using a straight edge, draw straight lines to connect the marks.

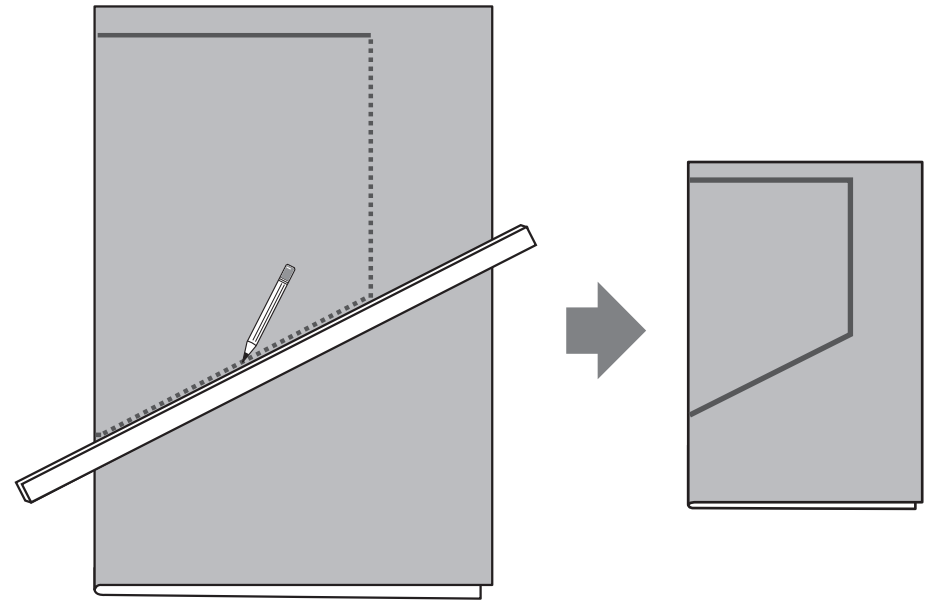

Step 5-Sew Double Jabot

- Cut the face fabric and lining. If using interlining, cut interlining as well.
- With right sides together, using a $\frac{1}{2}$ " seam allowance, stitch the face fabric and lining together on all sides except the top.
- Trim the corners. Turn right side out and press.

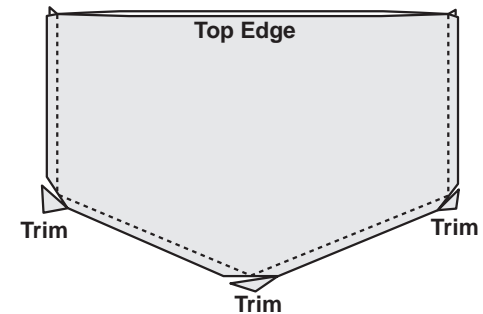

Step 6-Position and Pin Jabot Pleating Tapes

- Lay the double jabot sideways on the table with the face fabric up, as shown below.
- Draw a center line on the jabot with disappearing marking pen (Stock# **PM21** or **PM22**).
- Place the first Jabot Pleating Tape along the top edge of the double jabot. Position the second tape parallel to the first tape. Align the 0" mark on both tapes with the center line.
- Pay attention **ONLY** to the portion of the Jabot Pleating Tape with the color that matches the color of the width number that was noted in Step 2. For the example used here: to make a 6" finished half width double jabot with two pleats, refer **ONLY** to the red portion of the Jabot Pleating Tape.
- Pin the tapes to the jabot at each pair of matching color dots. Make sure the pins catch **BOTH** the face fabric **AND** the lining.

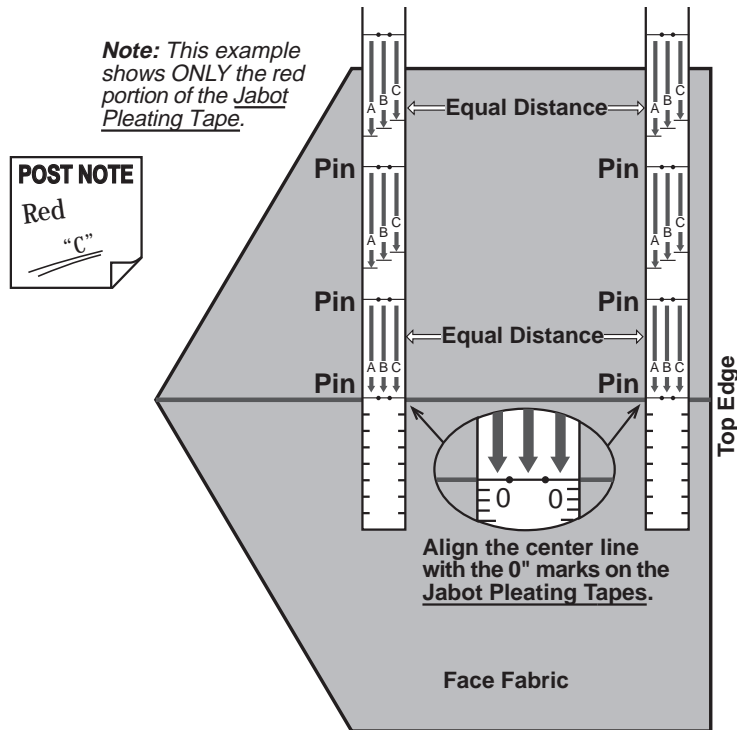

Step 7-Fold Double Jabot

- Skip the first pair of pins at the center line, pick up the Jabot Pleating Tapes and jabot by each pair of pins. Following the arrow with the appropriate color and letter, fold over in the arrow direction to align the pins with the horizontal lines pointed by the arrows.
- Pin the fabric to secure the pleat, as shown.
- Repeat folding and pinning at each pair of pins. This forms the evenly placed pleats.
- Leaving the pins you just set in place, remove the pins from both Jabot Pleating Tapes. Remove both Jabot Pleating Tapes.
- Repeat Steps 6 and 7 on the other half of the double jabot.

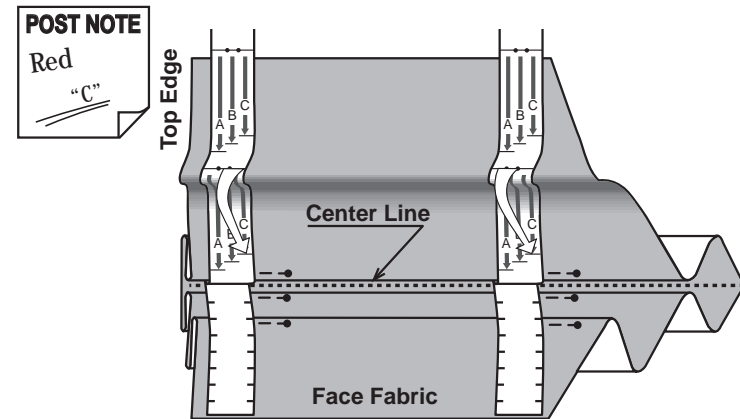

Step 8-Secure Pleats

- Stitch along the top edge to secure all the pleats. Remove pins from the double jabot.
- To mount, refer to page 10.

Q & A

Q1: My fabric has a dominating pattern. I know that I should cut the pair of jabots mirror imaging from each other, but how do I do that?

A: As shown below, if fabric motif is NOT symmetrical, the two jabots are NOT going to be mirror images. The two jabots should be cut so the main pattern occupies approximately the same location. Placing the main pattern at eye level is often considered more attractive.

You also need extra fabric yardage. For a pair of the same size jabots with no seam:

$$\text{Yardage} = (\text{Long point} + 2'' + 1 \text{ repeat}) \times 2$$

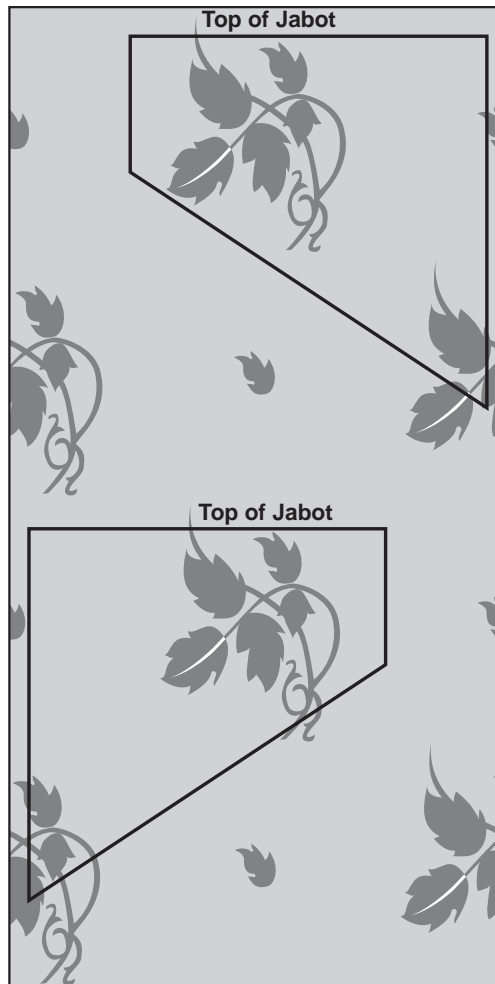

Q2: How do I make a jabot with a pointed return?

A: Some customers prefer a pointed return, as shown.

Un-pleated:

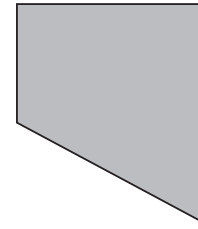

Pleated:

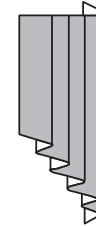

In Step 3 in the instructions, find the desired jabot long point length on the dashed line at the return side of the template, BUT do not mark. Instead, mark at the desired return and connect the dots and line.

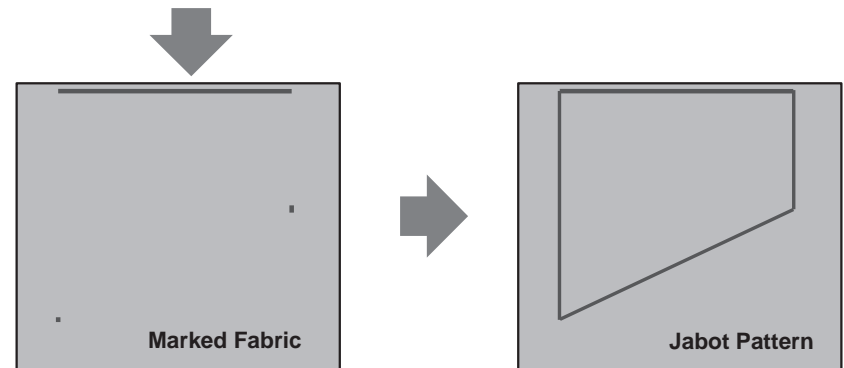
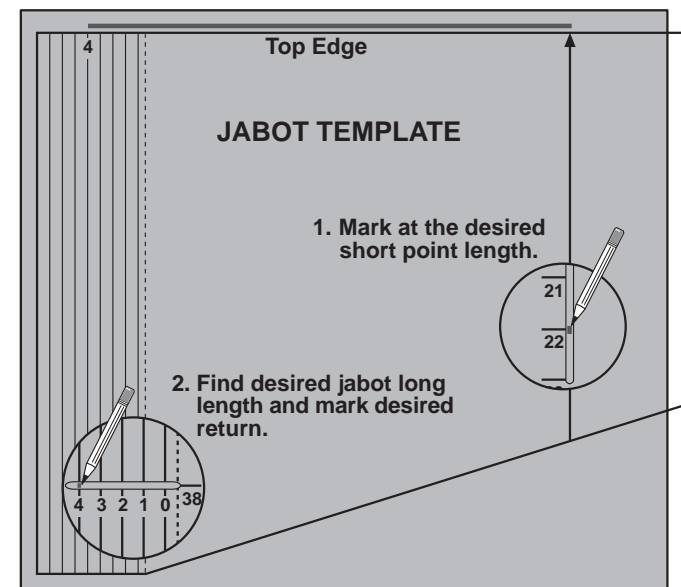

Q3: How do I cut a contrast color band like the ones shown here?

Un-pleated:

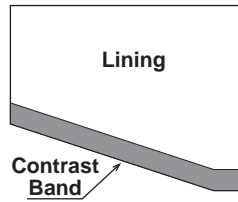

Pleated:

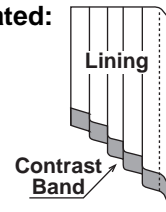

A: After marking and cutting the fabrics for the jabot, place the Jabot Template on the fabric. Make sure the jabot's long point lines up with the black dot at the bottom of the template. As the example below shows, the diagonal bottom of the jabot falls in the range indicated by the Template as 7".

On the fabric for the contrast band, using the jabot you have cut as a template, trace the return and diagonal bottom edge. Next, move the jabot 7" up and trace the return and diagonal bottom edge again. Draw vertical lines to connect the marks. Cut the contrast band. No adjustment for seam allowance is needed. Make sure that the band is cut along the same grain direction as the jabot.

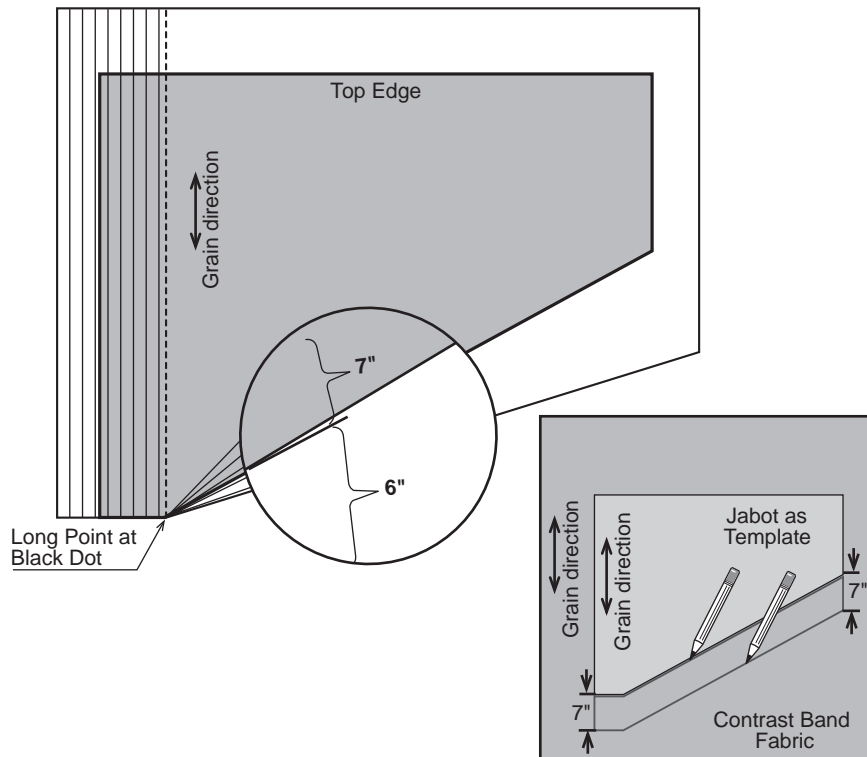

For jabots with pointed returns, position the Jabot Template on the fabric. Align the dashed line on the template with the return edge of the jabot, as shown.

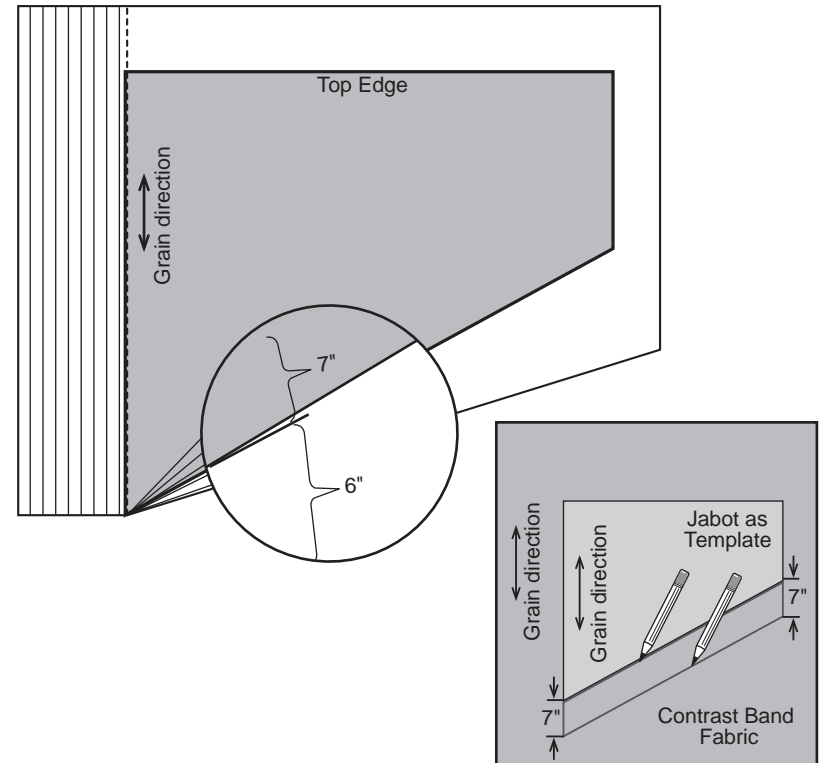

Q4: How do I mount my swags and jabots?

A: You can staple or use hook and loop tapes to mount swags and jabots to dustboards or rods. Wrap and sew a piece of Swag/Jabot Mounting Tape (Stock# **HJ222**) along the top unfinished edge of the treatment. make sure that loop half is on the lining side and hook half is on the face fabric side. Staple hook tape (Stock# **HT100**) to the dustboard front edge or spiral wrap pressure sensitive hook tape (Stock# **HPS100**) around the rod. Attach swags and jabots to the dustboard or rod.

Q5: I am using blackout lining in my jabots. Can I use this system?

A: Yes, but with caution. You cannot use pins to pin the Jabot Pleating Tapes to your jabot fabric since the holes left by the pins let light shine through. However, you can place the Jabot Pleating Tapes on your jabot and use disappearing marking pen (Stock # **PM21** or **PM22**) to mark all the pleats.

Q6: I have to make a pair of asymmetrical jabots. One is longer than the other. Should I keep the short point lengths of both jabots the same, or keep the slanted bottom angles the same?

A: This is entirely a design preference. The diagrams below illustrate the two variations. Each conveys a very different look.

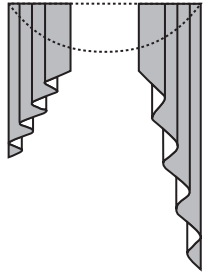

Same Short Point Length

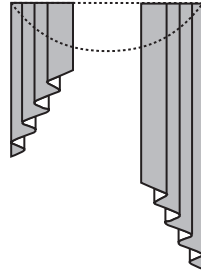

Same Slanted Bottom Angle

To keep the slanted bottom angle the same, mark and cut the shorter jabot first. Then flip it over and use it as a template to mark the longer jabot along the slanted edge.

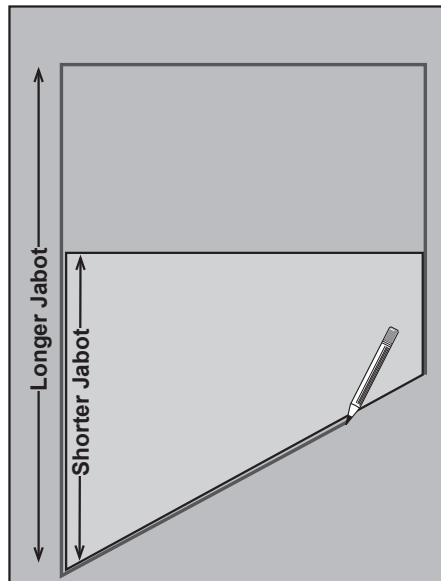

Q7: When there are jabots with different widths, how do I keep a uniform look in one room?

A: You may keep the same number of pleats per jabot and vary the spacing; or, keep the same spacing, but vary the number of pleats per jabot. Alternatively, you may vary BOTH the number of pleats AND the spacing. Different looks are shown in the following diagrams.

The jabot spacings are indicated by the different colors on the template. If the jabot finished width is printed in black - spacing is $1\frac{1}{2}$ - 1", printed in red - spacing is $1\frac{1}{2}$ - 2", printed in green - spacing is $2\frac{1}{2}$ - 3".

Same Number of Pleats, but Different Spacing

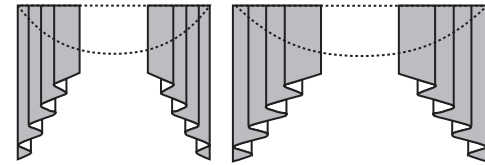

Same Spacing, but Different Number of Pleats

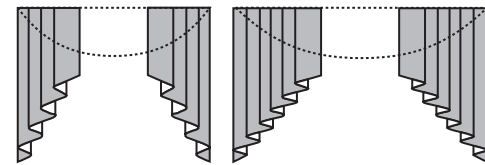

Change BOTH Spacing AND Number of Pleats

