

AUTOMATE® DC SOFT SHADE SYSTEMS

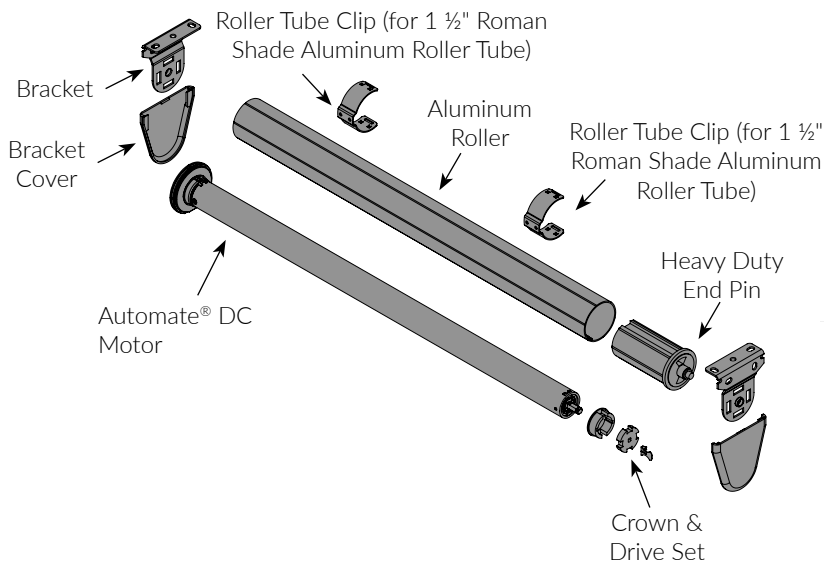

ADDITIONAL OPTIONS

- Motor End Covers

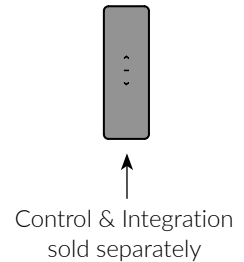
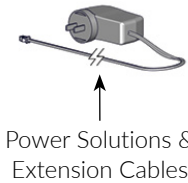

1 – CHOOSE YOUR SHADE QUANTITY

Let our in-house experts know how many shades to assemble.

2 – CHOOSE YOUR SHADE WEIGHT

Shade Weight determines Motor Size. Up to 13 lbs. or up to 23 1/2 lbs.

3 – CHOOSE YOUR LIFTING MATERIAL

Select from Encased Lift Cord Tube or 6" Lift Band.

**Builds do not include Lift Cord or Lift Band. Remember to order Lift Cord or Lift Band.*

4 – CHOOSE YOUR SHADE DIMENSIONS

Maximum size for 13 lb. system is 84" x 84". Minimum shade width is 18".

Maximum size for 23 1/2 lb. system is 120" x 120". Minimum shade width is 23 1/2".



5 – CHOOSE YOUR LIFTING MATERIAL SPECIFICATIONS

Select the Number of Columns of lifting material on the shade. Indicate the distances between each column. Minimum spacing for Lift Band = 8"; Encased Lift Cord = 7".

6 – CHOOSE YOUR SHADE MOUNT

Select Front / Standard or Reverse Mount, as well as Motor Placement Left or Right.

7 – CHOOSE YOUR MOTOR POWER & ACCESSORIES

Select from Power Supplies, or a Battery Tube/Pack with optional Eco Friendly Solar Panel Battery Charger.

8 – CHOOSE YOUR CONTROL & INTEGRATION

Sold separately - see [compatibility chart](#). Select from a variety of remotes and wall switches, or take your shade control to the next level by upgrading to a hub to integrate your shades with whole home and voice control systems.

AUTOMATE® DC SOFT SHADE SYSTEM

REV February 1, 2025

Encased Lift Cord or 6" Lift Band | BUILDS DO NOT INCLUDE LIFT CORD OR LIFT BAND

12" cords are only included to show the correct routing
Systems are built with 1 1/2" diameter roller tube



A DIVISION OF ROLLEASE ACMEDA

ACCOUNT # _____

Company _____ Contact _____ Date _____
 Street Address _____ Person to contact with technical questions _____
 City _____ State _____ Zip _____ PO _____ Phone _____
 Email _____ (required for shipping confirmation)
 Ship to (if different from above) _____ Attn _____
 Street Address _____ City _____ State _____ Zip _____

PLEASE COMPLETE ITEMS 1 THROUGH 9.

For assistance, call Customer Service at 866.985.3423.
Email completed form to rteautomation@RowleyCompany.com.

1 Total number of shades to be made to these specifications → (Use another order form for shades with different specifications)

2 SHADE WEIGHT: Include the weight of the fabric, lining, stiffeners & bottom weights.

UP TO 13 LBS.
25 mm motor size | CSRTMDCZ25112
(On 1 1/2" tube)

UP TO 23 1/2 LBS.
28 mm motor size | CSRTMDCZ28112
(On 1 1/2" tube)

2 1/4" WIDTH BRACKETS INCLUDED
1 3/8" Proj.
RSB10

SEE ALL BRACKETS FOR COMPARISON »

3 TYPE OF LIFTING MATERIAL ENCASED LIFT CORD TUBE 6" LIFT BAND

4 EXACT SHADE DIMENSIONS in inches. We do not make any additional deductions.
Maximum size for 13 lb. system is 84" x 84". Minimum shade width is 18".
Maximum size for 23 1/2 lb. system is 120" x 120". Minimum shade width is 23 1/2".

WIDTH

Dustboard size 3/4" x 2 1/2"

5 NUMBER OF COLUMNS OF LIFTING MATERIAL ON THE SHADE. INDICATE THE DISTANCES BETWEEN EACH COLUMN OF LIFTING MATERIAL ON THE SHADE.

Minimum spacing for Lift Band = 8"; Encased Lift Cord = 7". Your headrail will be built according to the measurements you provide on the chart below. Your sketch doesn't have to be to scale, but THE NUMBERS MUST BE ACCURATE to the nearest 1/8". Draw vertical lines to show the columns of Encased Lift Cord. Be sure to include every column, including those close to the edges of the headrail. The first two columns are sketched for you. Write the measurements to indicate the distance between each column of Encased Lift Cord and the next. CHECK THAT THESE MEASUREMENTS ADD UP TO THE EXACT SHADE WIDTH IN ITEM 4.

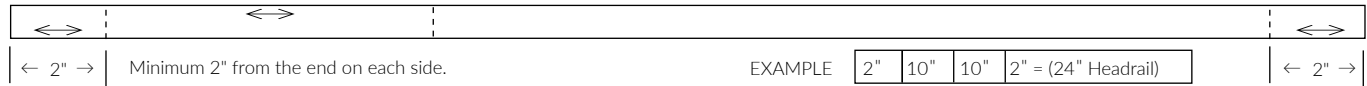

6 SHADE MOUNTING: Shades are typically mounted over the front of the operating system. Indicate if you plan to mount to the back of the operating system by checking the box. No additional charge.

FRONT MOUNT STANDARD REVERSE MOUNT
 MOTOR LEFT MOTOR RIGHT

***ACCESSORIES & CONTROL & INTEGRATION BELOW IN ITEMS 7 & 8 SOLD SEPARATELY.**

7 ACCESSORIES* Requires Battery Tube, Battery Pack or Power Supply.

BATTERY TUBE | \$34.65 (use with 25 mm motor only)
 SOLAR PANEL | \$127.20

RECHARGEABLE BATTERY PACK | \$100.09
 BATTERY CHARGER (Required) | \$15.90
 CHARGER CABLE EXTENDER 48" | \$9.00

POWER SUPPLY 5' | \$40.53
 POWER CABLE EXTENDER 48" | \$5.78
 POWER SUPPLY 10 1/2' | \$86.63
 POWER CABLE EXTENDER 48" | \$5.78

8 CONTROL & INTEGRATION* 1 control required for system to function - sold separately.

HANDHELD REMOTE OPTIONS 65' Range
 Push 1 ch | \$68.90 | Push 5 ch | \$74.20 | Push 15 ch | \$79.50
 White Black White Black White Black

CUT-IN MOUNT SWITCH OPTIONS 65' Range, Requires RTMSMB/W \$9.01
 1 Ch white \$53.68 | 2 Ch white \$59.99 | 15 Ch white \$79.50

SURFACE MOUNT WALL SWITCH | \$74.20 (5 Channel, 65' Range)

AUTOMATE PULSE 2 HUB | \$270.30 (60' Range)
 ARC USB SIGNAL REPEATER | \$127.20 (Extends the wireless range of the Automate® Pulse 2 Hub & Remotes up to 60')
 WALL CHARGER | \$15.90

INTERIOR SUN SENSOR | \$47.70 (65' Range)
 BOND BRIDGE PRO HUB | \$379.00 (3,500 sq. ft. Range)

9 READ THE TERMS OF SALE on the Custom Solutions Payment Form on page 3, sign and submit along with your signed forms.

*Builds do not include Lift Cord or Lift Band. Remember to order Lift Cord or Lift Band.

SHIPPING » [Flat Rate Shipping Program](#) Lengths over 8' will ship truck and incur an oversized fee. Splicing options for overlength sizes and alternative freight quotes available.

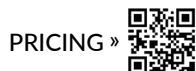

PRICING »

Rowley® Company
230 Meek Road / Gastonia / NC / 28056
Phone » Motorized Systems 866-985-3423
© 2025 Rowley® Company, LLC

Signature of purchaser / cardholder

Date

PAYMENT FORM

ACCOUNT # _____

To place a Custom Solutions Shade System or Drapery Hardware System order, you must complete and sign the Payment Form along with the applicable system build form. You may submit your completed forms via email to Sales@RowleyCompany.com.

For Order Forms, visit RowleyCompany.com/CustomSolutions

<input type="radio"/> OVERNIGHT SHIPPING (additional freight will apply)	SHIPPING » Flat Rate Shipping Program Lengths over 8' will ship truck and incur an oversized fee. Splicing options for overlength sizes and alternative freight quotes available.								
SELECT ONE <input type="radio"/> <input type="radio"/> <input type="radio"/> <input type="radio"/>	EXPIRATION DATE <table border="1" style="width: 100%; height: 20px; border-collapse: collapse;"> <tr> <td style="width: 25%;"></td> <td style="width: 25%;"></td> <td style="width: 25%;"></td> <td style="width: 25%;"></td> </tr> </table>								
CREDIT CARD # - LAST 4 DIGITS <table border="1" style="width: 100%; height: 20px; border-collapse: collapse;"> <tr> <td style="width: 25%;"></td> <td style="width: 25%;"></td> <td style="width: 25%;"></td> <td style="width: 25%;"></td> </tr> </table>					SECURITY CODE <table border="1" style="width: 100%; height: 20px; border-collapse: collapse;"> <tr> <td style="width: 25%;"></td> <td style="width: 25%;"></td> <td style="width: 25%;"></td> <td style="width: 25%;"></td> </tr> </table>				
I authorize Rowley® Company to charge the credit card above for all of my orders submitted to Rowley® Company. I have read, understood and agree to the Terms of Sale on this payment form.									
<table border="1" style="width: 100%; border-collapse: collapse;"> <tr> <td style="text-align: center; padding: 5px;"> Credit Card Billing Address (if different than ship to address) </td> </tr> <tr> <td style="padding: 5px;"> Complete Name of Card Holder _____ Street Address _____ City _____ State _____ Zip _____ Phone _____ Email _____ </td> </tr> </table>	Credit Card Billing Address (if different than ship to address)	Complete Name of Card Holder _____ Street Address _____ City _____ State _____ Zip _____ Phone _____ Email _____	<table border="1" style="width: 100%; border-collapse: collapse;"> <tr> <td style="padding: 5px;"> <input type="checkbox"/> Ship and apply to my pre-approved Net 30 account. Account # _____ </td> </tr> </table> <p style="font-size: small; margin-top: 10px;"> The price of the custom build includes all parts, labor and packaging, but does not include sales tax where applicable or shipping charges, for which the receiver is responsible. All orders will ship within five business days from confirmation of order with satisfactory payment arrangements. Automated® Traverse orders will ship within 10 - 15 business days. For commercial orders, request a quote with timeline. Terms: Net 30 days to pre-approved accounts only or credit card. Prices, design and availability are subject to change or withdrawal without notice. </p>	<input type="checkbox"/> Ship and apply to my pre-approved Net 30 account. Account # _____					
Credit Card Billing Address (if different than ship to address)									
Complete Name of Card Holder _____ Street Address _____ City _____ State _____ Zip _____ Phone _____ Email _____									
<input type="checkbox"/> Ship and apply to my pre-approved Net 30 account. Account # _____									
_____ Signature of purchaser / cardholder	_____ Date								

TERMS OF SALE WARRANTIES BY ROWLEY® COMPANY

Rowley® Company agrees to repair or replace, free of charge, any Custom Solutions Shade or Track System that due to faulty parts or workmanship in the assembled Shade or Track System is returned freight pre-paid to Rowley® Company within ninety (90) days of delivery. The parts in the system are covered by a ten year warranty. These warranties do not cover systems that have been subjected to abuse. The Slim Drapery Motor is covered by a 5 year warranty.

Orders for Custom Solutions Shade or Track Systems are not cancelable and cannot be altered. Custom Solutions Shade or Track Systems are not returnable for any reason except warranty repair, as described above. The buyer verifies that all sizes and other specifications are correct. A Custom Solutions Shade or Track System will be custom-built to the size and other specifications written on the system order form. Rowley® Company will repair or replace without charge any Custom Solutions Shade or Track System that is not made correctly to those specifications. **THE CUSTOMER WILL BE CHARGED FOR ANY REPAIRS OR REPLACEMENT NECESSITATED BY AN ERROR IN THE MEASUREMENT OR OTHER SPECIFICATIONS.**

OWNERSHIP: All selected shipping preferences are F.O.B. shipping point from any Rowley® location; the buyer owns the shipment as soon as it leaves the Rowley® Company loading dock. In the event of damaged shipment, the buyer must accept the shipment and place a claim with the carrier. Prices quoted include all parts, labor and packaging for all Custom Solutions Shade or Track Systems. The buyer is responsible for shipping costs.