



# R-TEC Smart Controls - Handheld Remote, 5 Channel RTMHR5C

## TECHNICAL DATA / PACK CONTENTS

### PRODUCT SPECIFICATIONS

Parameters	Value
Voltage	3 V DC
Battery	CR2430
Radio Frequency	433.92 MHz
Transmitting Power	10 milliwatt
Transmission Range	65'
Temperature Working Range	50° F - 122° F (10° C - 50° C)

### PACK CONTENTS

1. Handheld Remote with Wall Mount, 5 Channel
2. Cradle and Wall Fixing Screws
3. Instruction Manual
4. 3 V - CR2450 Battery
5. Screwdriver



# INSTALLATION

## WALL MOUNTING

Use supplied fasteners and anchors to attach the base to wall.

Replace cover by pressing snap latches into place.

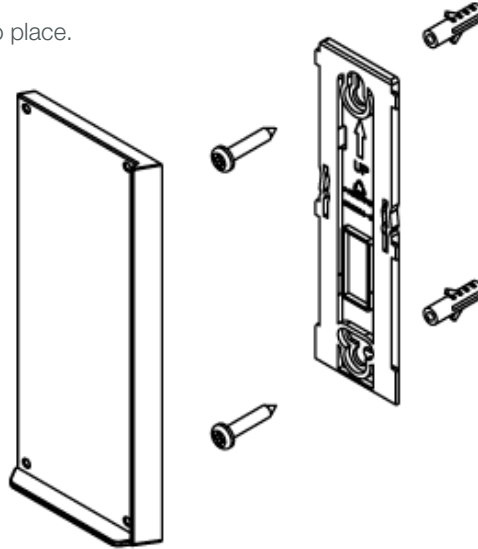

---

## REMOTE BATTERY

Remove cover from remote; unscrew with screwdriver included, then firmly press down and slide left.

Insert battery as directed, then slide cover back on remote and screw on with screwdriver included.

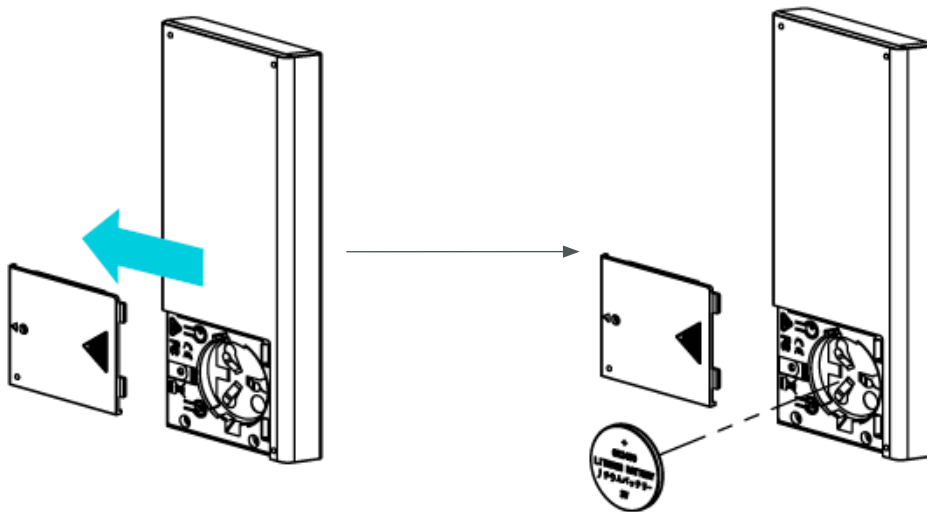

# FUNCTIONAL OVERVIEW

## BUTTONS

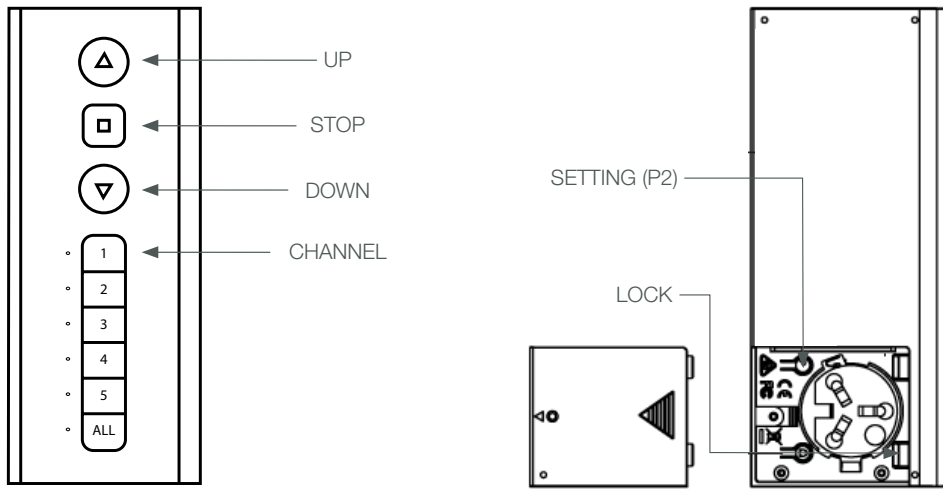

## SELECTING A CHANNEL



### IMPORTANT

To determine which channel is activated prior to programming or operating the control simply press and release any of the 'channel' buttons or the 'stop' button once and the active channel or channels will illuminate.



### IMPORTANT

You can program one channel at a time but you can operate several channels at once if desired after the programming has been completed.

Select a channel by 'toggling' it on until a blue LED is showing next to it. This will require pressing and releasing the channel once or twice until the light appears.

Deselect the channels that you don't want to be active by 'toggling' them off until the blue LED disappears.



Now only the channel that you want to program or operate will be active. Your selected channel is now ready to be programmed or operated.



### IMPORTANT

When a channel is selected, the blue LED will stay illuminated for four seconds and then go out. The channel remains active. Programming and operation of the window treatment(s) on the channel can proceed without reselecting the channels.

# GROUP CONTROL

Channel ALL is preset to control all window treatments paired to your multi channel remote.

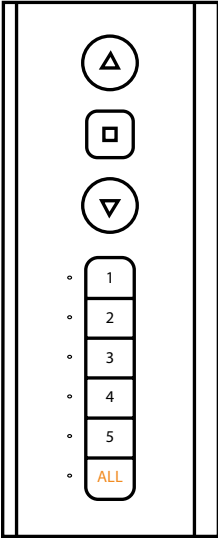

# PROGRAMMING



## IMPORTANT

Please refer to the relevant documentation of your motor model for instructions on adjusting motor settings.

## QUICK START PROGRAMMING

- 1 Select a single or multiple channels by toggling channels (3) as required. Note the corresponding LED next to each channel.

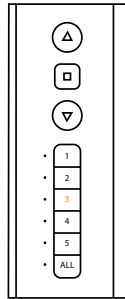

- 2 Hold P1 button on motor head for 2 seconds until the motor responds as below.

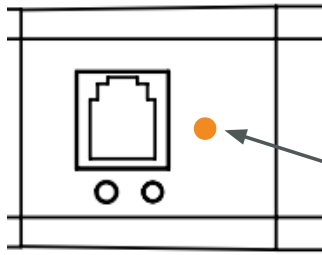

Motor Response



- 3 Within 4 seconds, hold the STOP button on remote for 3 seconds. The motor will respond as below.

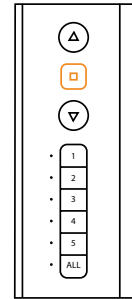

Motor Response



- 4 Press UP or DOWN to check the motor direction. If correct, skip to step 5 of setting the upper limit.

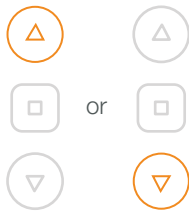

If the window treatment direction needs to be reversed; press and hold the UP and DOWN together for 5 seconds until the motor Jogs.

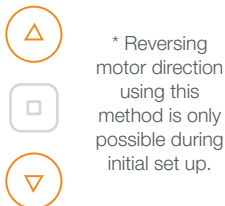

Motor Response



- 5 Move window treatment to desired top limit by pressing the UP arrow repeatedly. Then press and hold UP and STOP together for 5 seconds to save the limit.

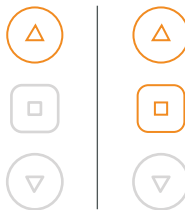

Motor Response



- 6 Repeat steps 1-6 for all motors. Once complete, press and hold the LOCK button for 6 seconds while looking at the LED, and hold until solid.

Approx. 6 SECS

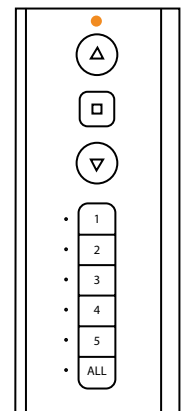
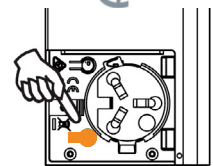

## SET A FAVORITE POSITION

Move window treatment to desired position by pressing **UP** or **DOWN** on the remote.

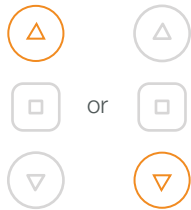

Press **P2** on the controller.

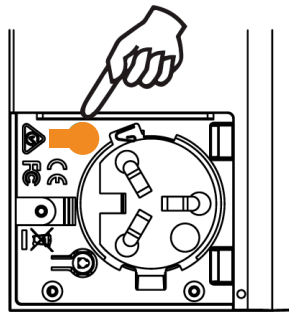

Motor Response

**JOG X1** **BEEP X1**

Press **STOP** on the controller.



Motor Response

**JOG X1** **BEEP X1**

Press **STOP** again on the controller.



Motor Response

**JOG X2** **BEEP X3**

## DISABLE LIMIT SETTING FUNCTION OF REMOTE



### IMPORTANT

This mode is intended to be used after all window treatment programming is completed. User Mode will prevent accidental or unintended changing of limits.

Push **LOCK** button to lock or unlocked position

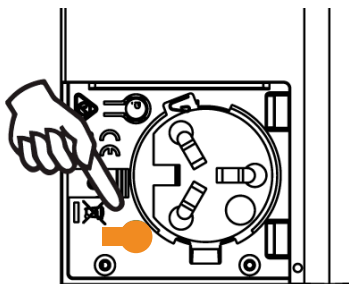

Pressing the **LOCK** button for 6 seconds will toggle between locked and unlocked LED show solid or flashing.

LED solid on when locked  
LED blinking when unlocked

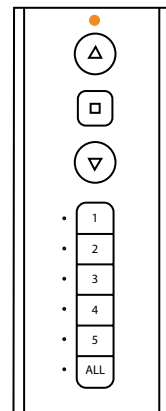

# ADDING OR REMOVING CONTROLLERS & CREATING GROUP CHANNELS

## USING MOTOR P1 BUTTON

Hold **P1** button on motor head.

Hold **STOP** on switch.

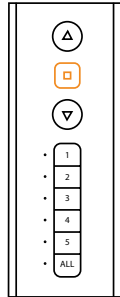
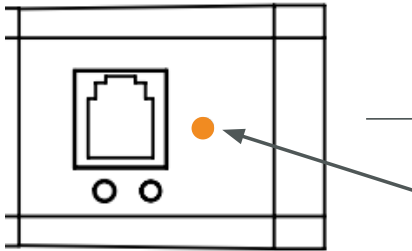

Motor Response

Motor Response



## USING PRE-EXISTING CONTROLLER

A = Existing button or channel (to keep).

B = Button or channel to add or remove.

Select the channel (5) you want to transfer.  
Press **P2** on existing remote.

Press **P2** a second time on existing remote.

Press the channel (1) on new remote.

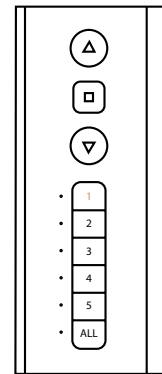
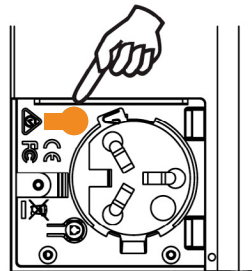
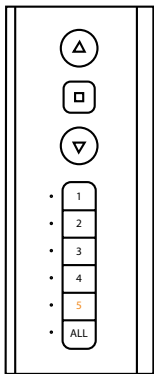

Motor Response

Motor Response

Motor Response



# TROUBLESHOOTING

Problem	Cause	Remedy
Motor is not responding	Remote battery is discharged	Replace battery.
	Battery is inserted incorrectly	Check battery polarity.
	Radio interference / Shielding	Ensure remote is positioned away from metal objects and that antenna on motor or receiver is kept straight and away from metal.
	Receiver distance is too far from remote	Move remote to a closer position or consider a repeater for improved performance.
	Power failure	Check power supply to motor is connected and active.
	Incorrect wiring	Check wiring is connected correctly (refer to motor installation instructions).
Cannot set limits on a single motor (multiple motors respond)	Using "Group" channels to adjust motor limits Red LED is solid	Always reserve an individual channel for programming functions.
		SYSTEM BEST PRACTICE - Provide an extra 5 channel remote in your multi motor projects, that provides individual control for each motor for programming purposes.

## Any Questions?

Contact our R-TEC Automation® in-house experts at 866.985.3423. Email us at [RTECAutomation@RowleyCompany.com](mailto:RTECAutomation@RowleyCompany.com).