

Roller Shade Installation Instructions Using an Automate® DC or Battery Motor - 25 mm or 28 mm

Please read all instructions before starting

INTRODUCTION:

The **Roller Shade Motorized System** is used to electronically control the shade using a motor and remote control. The total allowable weight will depend on the motor selected (see the chart below for allowable shade weights). By using a remote control or the smart phone app the operator can raise and lower the shade smoothly and precisely. **Figure 1** shows an assembled roller shade with motor and end brackets.

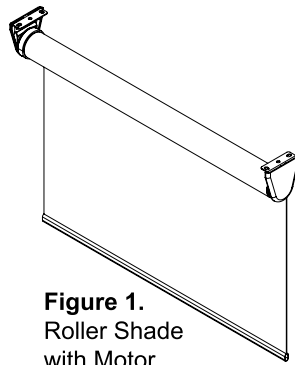

Figure 1.
Roller Shade with Motor

The **Roller Shade** can be mounted either inside or outside the window casing. For an inside mount, mount the brackets as close to the window as possible, yet have enough space for the shade fabric when completely rolled up.

The shade can be regular wind or reverse wind as shown below in **Figure 2**.

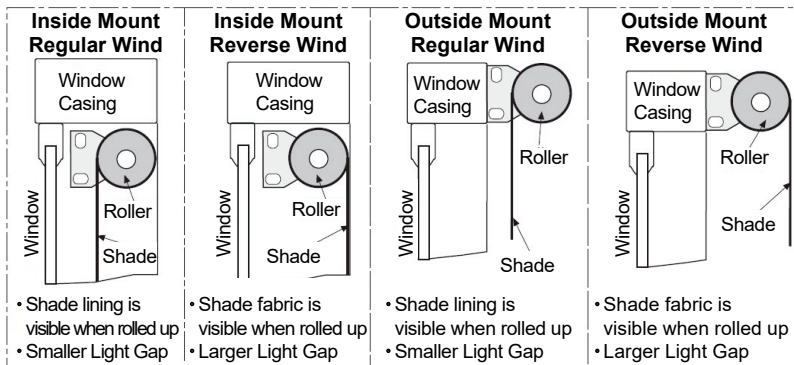

Figure 2. Side view on the top portion of the window

ALLOWABLE SHADE WEIGHTS:

Tubular Motor Item #	Motor Type	Tube Dia.	Maximum Shade Size	Min. Roller Shade Width/Roller Tube Length	Minimum Roman Shade Width/Dustboard Length	Maximum Shade Weight
MT01-1325-069028	Battery	1 1/4"	84" x 84"	20"	21 1/2"	15.5 lbs.
		1 1/2"	84" x 84"	22"	23 1/2"	13.0 lbs.
MT01-1325-069029	Battery	1 1/4"	84" x 84"	23"	24 1/2"	15.5 lbs.
		1 1/2"	84" x 84"	25"	26 1/2"	13.0 lbs.
MT01-1328-069008	Battery	1 1/2"	120" x 120"	28 1/2"	30"	23.5 lbs.
		2"	120" x 120"	28 1/2"	30"	17.5 lbs.
MT01-1225-069002	DC	1 1/4"	84" x 84"	16 1/2"	18"	15.5 lbs.
		1 1/2"	84" x 84"	16 1/2"	18"	13.0 lbs.
MT01-1228-069002	DC	1 1/2"	120" x 120"	22"	23 1/2"	23.5 lbs.
		2"	120" x 120"	22"	23 1/2"	17.5 lbs.
MT01-1325-069026	Battery	1 1/4"	84" x 84"	19"	20 1/2"	15.5 lbs.
		1 1/2"	84" x 84"	21"	22 1/2"	13.0 lbs.

PARTS LIST. See Figure 3.

1. Tubular Motor
2. Aluminum Roller
3. Heavy Duty End Pin
4. Wall Brackets
5. Bracket Covers
6. Crown and Drive Set
7. Tube Adapter (as required)

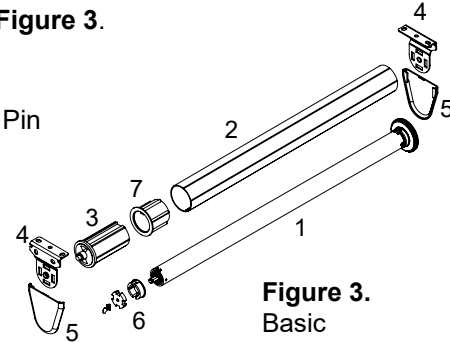
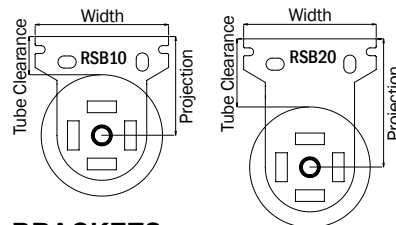

Figure 3.
Basic Components

BRACKETS & BRACKET COVERS:



BRACKET COVERS:

Item #	Fits
RSBC10/	RSB10
RSBC20/	RSB20

Available in White /W, Satin Nickel /SN and Black /K. Narrow brackets do not work with covers.

BRACKETS:

Item #	Proj.	Tube Clearance			Width
		1 1/4"	1 1/2"	2"	
RSNB10	1 5/8"	1"	7/8"	5/8"	1 1/2"
RSNB20	2 1/8"	1 1/2"	1 3/8"	1 1/8"	1 1/2"
RSNB30	2 7/8"	2 1/4"	2 1/8"	1 7/8"	1 1/2"

Zinc. Work with bracket covers.

Zinc. Don't work with bracket covers.

MEASUREMENT:

Step 1. See Figure 4.

- A. Inside Mount:** Measure the Width inside the casing (jam-to-jam, or casing-to-casing), where the brackets will be installed; and the Length from the top of the bracket to the bottom of the window. Mark your location.

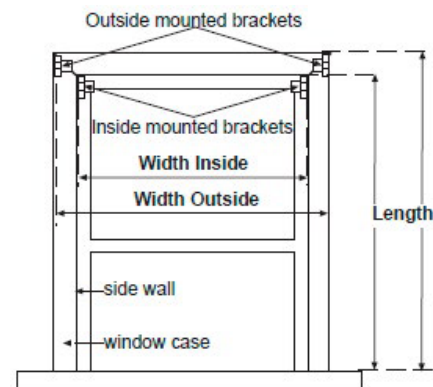

Figure 4. Measurements on a window

- B. Outside Mount:** Measure the Width outside between the outer edges of the window trim where the brackets will be installed; and the Length from the top of the bracket to the bottom of the window. Mark your location.

NOTE: Measure all windows for accuracy even though they may look the same.

FABRICATION:

Step 2. Cut shade cloth and aluminum roller.

A. Chart for Shade Cloth Width/Roller Tube Length

Tubular Motor Item #	Motor Type	Tube Dia.	Shade Cloth Width/ Roller Tube Length
MT01-1325-069028	Battery	1 1/4"	Overall Width - 1 5/16"
MT01-1325-069029		1 1/2"	Overall Width - 1 5/16"
MT01-1328-069008	Battery	1 1/2"	Overall Width - 1 5/16"
		2"	Overall Width - 1 5/16"
MT01-1225-069002	DC	1 1/4"	Overall Width - 1 5/16"
		1 1/2"	Overall Width - 1 5/16"
MT01-1228-069002	DC	1 1/2"	Overall Width - 1 5/16"
		2"	Overall Width - 1 5/16"
MT01-1325-069026	Battery	1 1/4"	Overall Width - 1 5/16"
		1 1/2"	Overall Width - 1 5/16"

Overall width is measured from outside edge of both brackets.

B. Chart for Shade Cloth Length (Finished Shade Cloth Length allows for a bottom bar pocket and to wrap around the roller at the top):

Tube Dia.	Finished Shade Cloth Length
1 1/4"	Length + 11"
1 1/2"	Length + 12"
2"	Length + 15"

NOTE: Cut the shade cloth square to ensure the shade will travel up and down and not track to the left or right.

INSTALLATION:

Step 3. Mount the brackets to the window casing according to the marked locations in **Figure 4** (see page 1). **Figure 6** shows the proper bracket placement options. The left and right Skyline brackets are identical so the motor can be mounted on the left or the right side.

A. To Inside of Window Casing

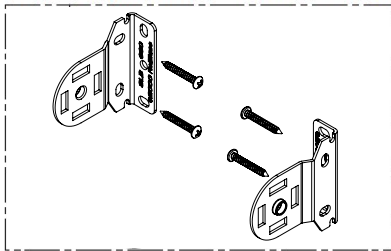

B. To Wall or Front of Window Casing

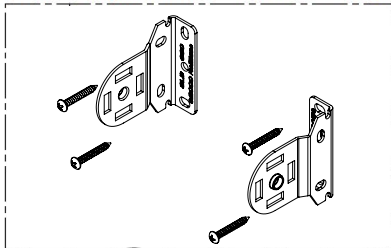

C. To Ceiling or Top of Window Casing

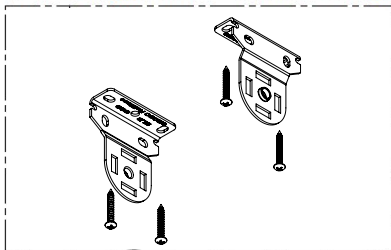

Figure 6. Install Brackets

Step 4. Slide the crown onto the motor as shown in **Figure 8**.

NOTE: Make sure to line up the notch in the crown and on the motor head.

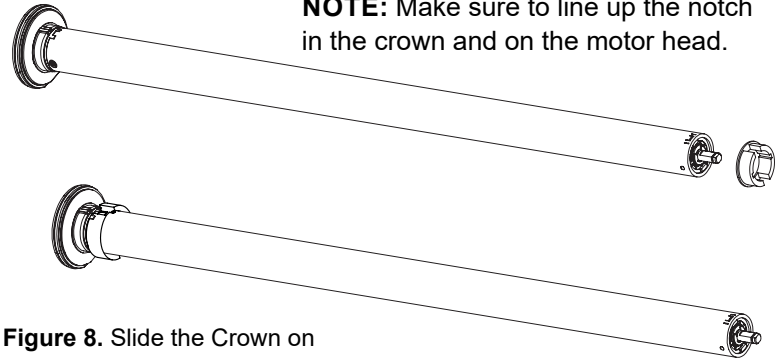

Figure 8. Slide the Crown on

Step 5. Slide the driver onto the end of the motor shaft. Then snap the drive retainer onto the motor shaft as shown in **Figure 9**.

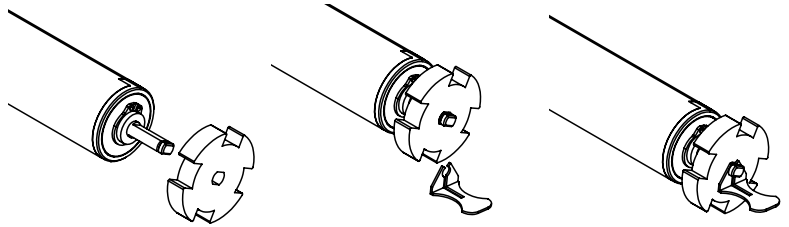

Figure 9. Slide the Driver on

Step 6. Insert the heavy duty end pin (and tube adapter where required) and the motor assembly into the roller tube. Make sure to line up the tabs on the tube with channels on the driver and crown as shown in **Figure 10**.

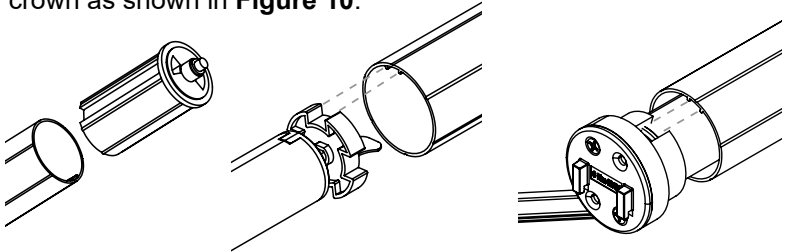

Figure 10. Insert the Heavy Duty End Pin and Motor Assembly.

Step 7. To install, insert the heavy duty end pin side of the tube into the center hole of the wall bracket shown in **Figure 11A**. While putting pressure on the spring pin, install the motor end onto the other bracket. The spring pressure will allow the tabs on the motor end to seat into the bracket as shown in **Figure 11B**.

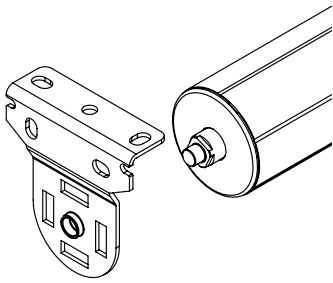

Figure 11A. End Pin Bracket

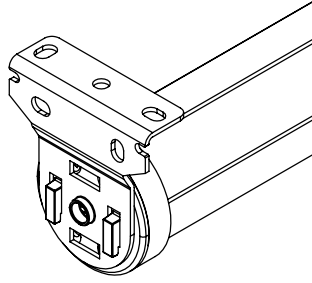
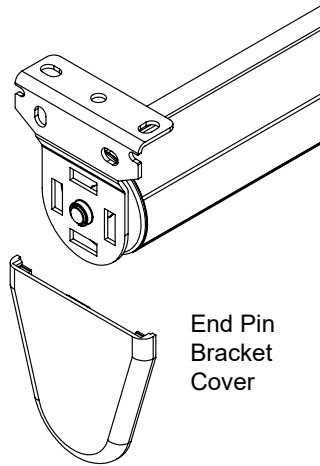

Figure 11B. Motor End Bracket

Step 8. Slide the bracket covers onto the brackets as shown in **Figure 12**.



End Pin
Bracket
Cover

Figure 12. Bracket Covers

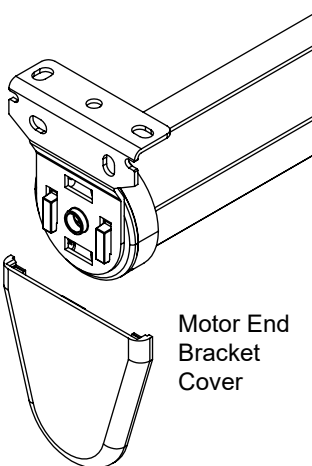

Motor End
Bracket
Cover

How to get started using your Motorized Roller Shade System with a Battery Motor:

- Please read all the instructions provided with your tubular motor.
- Your motor will be shipped in “sleep mode” and must be woken up before using.
- You will need a remote control or a smart phone to set up and control your tubular motor.
- Keep the cords and any loose fabric away from the rotating parts of the roller shade while in use.
- Only use charging options for your motor that are available through Rowley Company.
- Charge the battery motor fully before its first use, which will take approximately 6 hours.
- Battery motors will have an antenna cord out the end of the motor.

How to get started using your Motorized Roller Shade System with a DC Motor:

- Please read all the instructions provided with your tubular motor.
- Your motor will be shipped in “sleep mode” and must be woken up before using.
- You will need a remote control or a smart phone to set up and control your tubular motor.
- Keep the cords and any loose fabric away from the rotating parts of the roller shade while in use.
- Only use power options for your motor that are available through Rowley Company.

Roller Shade Installation Instructions Using an Automate® DC or Battery Motor - 35 mm

Please read all instructions before starting

INTRODUCTION:

The **Roller Shade Motorized System** is used to electronically control the shade using a motor and remote control. The total allowable weight will depend on the motor selected (see the chart below for allowable shade weights). By using a remote control or the smart phone app the operator can raise and lower the shade smoothly and precisely. **Figure 1** shows an assembled roller shade with motor and end brackets.

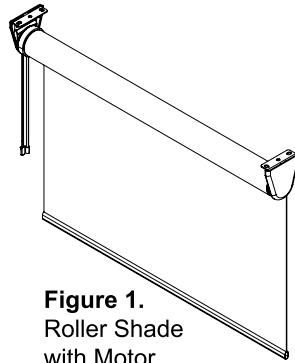

Figure 1.
Roller Shade with Motor

The **Roller Shade** can be mounted either inside or outside the window casing. For an inside mount, mount the brackets as close to the window as possible, yet have enough space for the shade fabric when completely rolled up.

The shade can be regular wind or reverse wind as shown below in **Figure 2**.

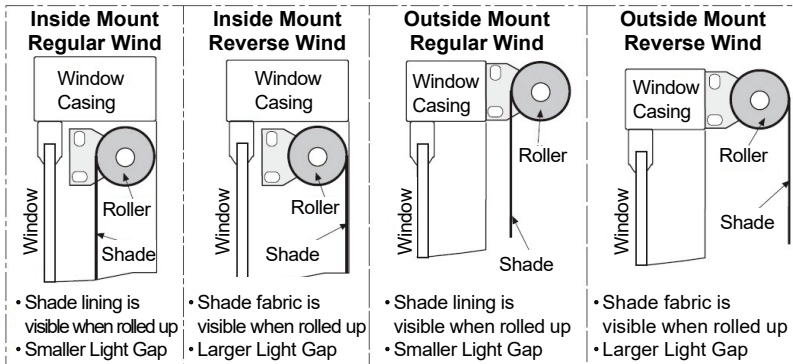

Figure 2. Side view on the top portion of the window

ALLOWABLE SHADE WEIGHTS:

Tubular Motor Item #	Motor Type	Tube Dia.	Maximum Shade Size	Minimum Roller Shade Width/ Roller Tube Length	Minimum Roman Shade Width/ Dustboard Length	Maximum Shade Weight
MT01-1335-069001	Battery	2"	120" x 120"	37.5"	39"	26.5 lbs.
MTDCRF35-3	DC	2"	120" x 120"	23.5"	25"	26.5 lbs.

PARTS LIST. See Figure 3.

1. Tubular Motor
2. Aluminum Roller
3. Heavy Duty End Pin
4. Wall Brackets
5. Bracket Covers
6. Crown and Drive Set
7. Motor Mount Plate with Screws
8. Tube Adapter

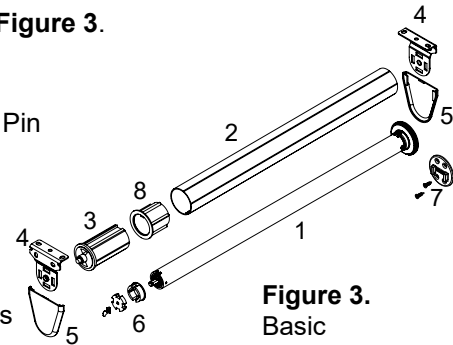
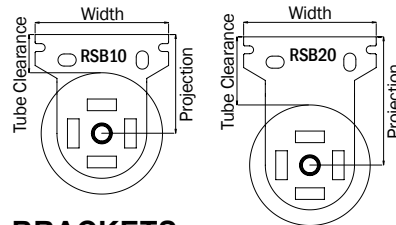

Figure 3.
Basic Components

BRACKETS & BRACKET COVERS:



BRACKET COVERS:

Item #	Fits
RSBC10/	RSB10
RSBC20/	RSB20

Available in White /W, Satin Nickel /SN and Black /K. Narrow brackets do not work with covers.

BRACKETS:

Item #	Proj.	2" Tube Clearance	Width
RSB10	1 5/8"	5/8"	2 1/4"
RSB20	2 1/8"	1 1/8"	2 1/4"

Zinc. Work with bracket covers.

Item #	Proj.	2" Tube Clearance	Width
RSNB10	1 5/8"	5/8"	1 1/2"
RSNB20	2 1/8"	1 1/8"	1 1/2"
RSNB30	2 7/8"	1 7/8"	1 1/2"

Zinc. Don't work with bracket covers.

MEASUREMENT:

Step 1. See **Figure 4**.

A. Inside Mount: Measure the **Width** inside the casing (jam-to-jam, or casing-to-casing), where the brackets will be installed; and the **Length** from the top of the bracket to the bottom of the window. Mark your location.

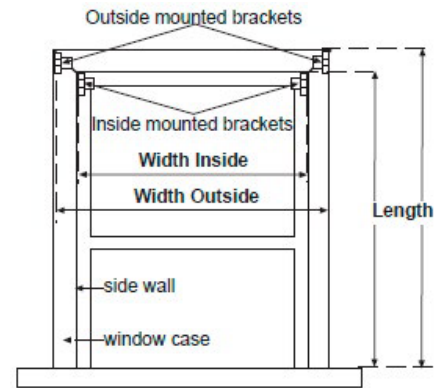

Figure 4. Measurements on a window

B. Outside Mount: Measure the **Width** outside between the outer edges of the window trim where the brackets will be installed; and the **Length** from the top of the bracket to the bottom of the window. Mark your location.

NOTE: Measure all windows for accuracy even though they may look the same.

FABRICATION:

Step 2. Cut shade cloth and aluminum roller.

A. Chart for Shade Cloth Width/Roller Tube Length

Tubular Motor Item #	Motor Type	Tube Dia.	Shade Cloth Width/ Roller Tube Length
MT01-1335-069001	Battery	2"	Overall Width - 1 7/16"
MTDCRF35-3	DC	2"	Overall Width - 1 7/16"

Overall width is measured from outside edge of both brackets.

B. Chart for Shade Cloth Length (Finished Shade Cloth Length allows for a bottom bar pocket and to wrap around the roller at the top):

Tube Dia.	Finished Shade Cloth Length
2"	Length + 15"

NOTE: Cut the shade cloth square to ensure the shade will travel up and down and not track to the left or right.

INSTALLATION:

Step 3. Mount the brackets to the window casing according to the marked locations in **Figure 4** (see page 1). **Figure 6** shows the proper bracket placement options. The left and right Skyline brackets are identical so the motor can be mounted on the left or the right side.

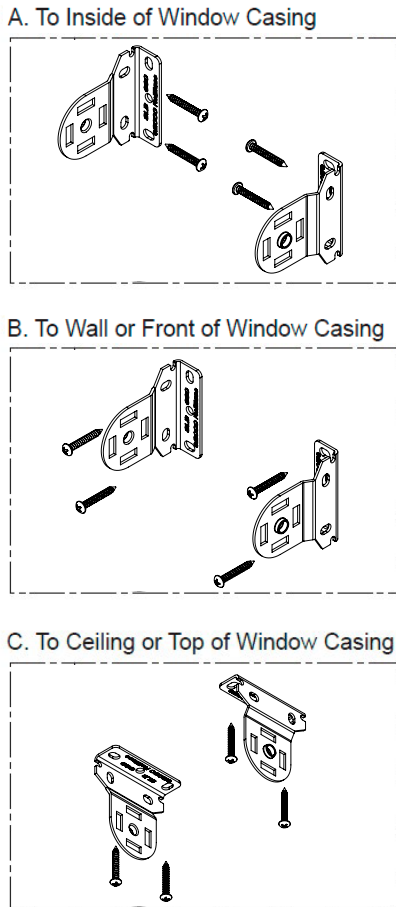

Figure 6. Install Brackets

Step 4. Install the motor mount plate to the tubular motor by using the screws provided and a Phillips screw driver, as shown in **Figure 7**.

NOTE: When mounting the plate it helps to mount it so the antenna and the power cord (on DC motor models) are pointed toward the back of the shade.

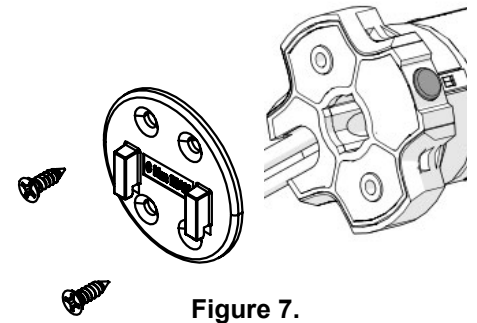

Figure 7. Install the Motor Mount Plate

Step 5. Slide the crown onto the motor as shown in **Figure 8**.

NOTE: Make sure to line up the notch in the crown and on the motor head.

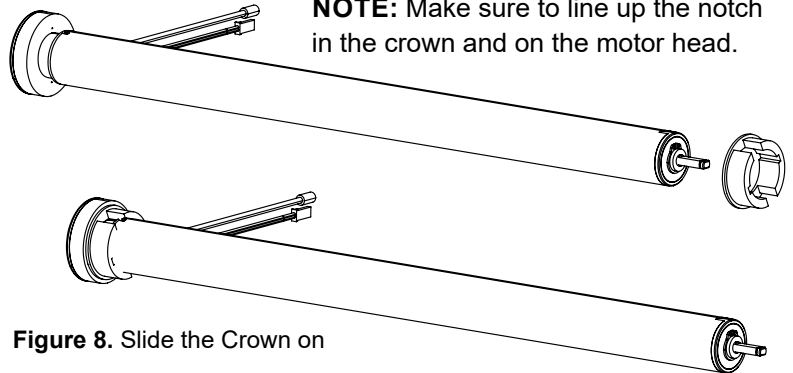

Figure 8. Slide the Crown on

Step 6. Slide the driver onto the end of the motor shaft. Then snap the drive retainer onto the motor shaft as shown in **Figure 9**.

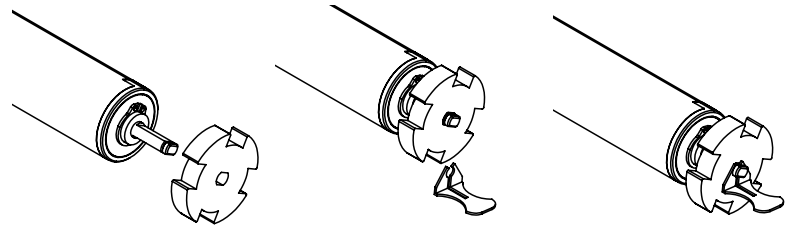

Figure 9. Slide the Driver on

Step 7. Insert the heavy duty end pin (and tube adapter where required) and the motor assembly into the roller tube. Make sure to line up the tabs on the tube with channels on the driver and crown as shown in **Figure 10**.

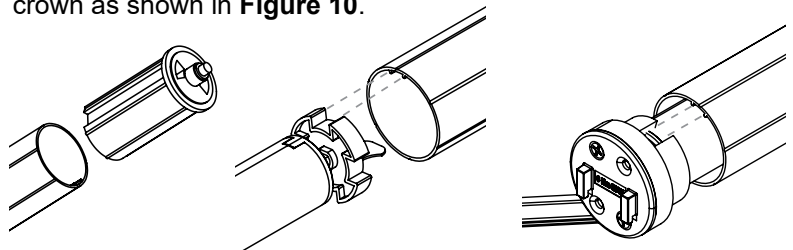

Figure 10. Insert the Heavy Duty End Pin and Motor Assembly.

Step 8. To install, insert the heavy duty end pin side of the tube into the center hole of the wall bracket shown in **Figure 11A**. While putting pressure on the spring pin, install the motor end onto the other bracket. The spring pressure will allow the tabs on the motor end to seat into the bracket as shown in **Figure 11B**.

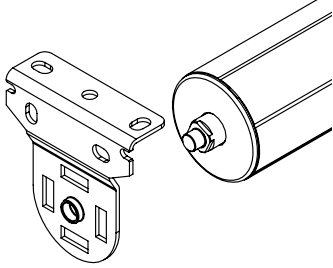

Figure 11A. End Pin Bracket

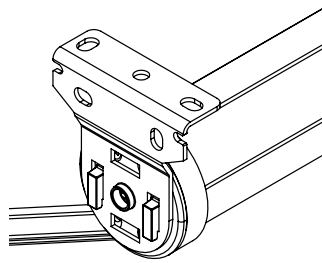
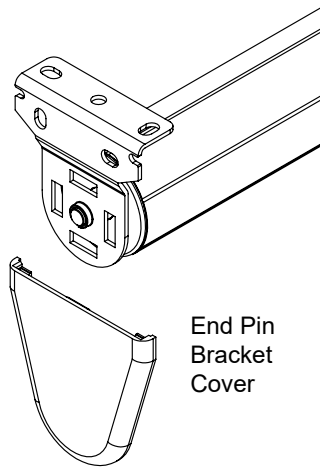

Figure 11B. Motor End Bracket

Step 9. Slide the bracket covers onto the brackets as shown in **Figure 12**.



End Pin
Bracket
Cover

Figure 12. Bracket Covers

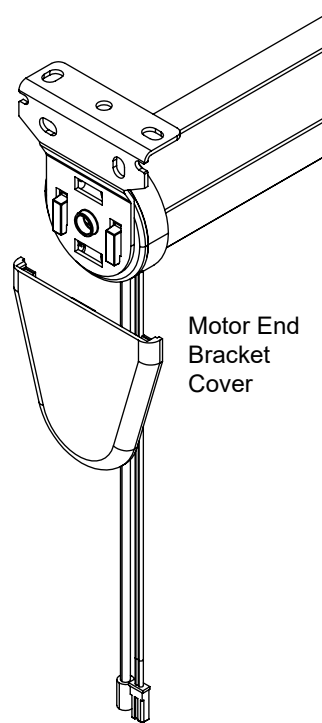

Motor End
Bracket
Cover

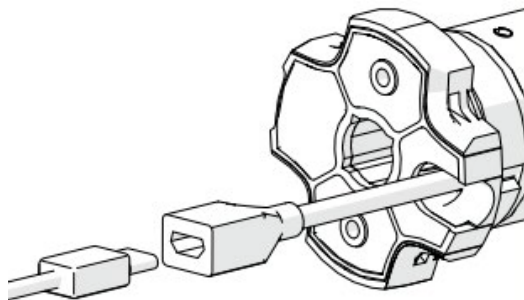

How to get started using your Motorized Roller Shade System with a Battery Motor:

- Please read all the instructions provided with your tubular motor.
- Your motor will be shipped in “sleep mode” and must be woken up before using.
- You will need a remote control or a smart phone to set up and control your tubular motor.
- Keep the cords and any loose fabric away from the rotating parts of the roller shade while in use.
- Only use charging options for your motor that are available through Rowley Company.
- Charge the battery motor fully before its first use, which will take approximately 6 hours.
- Battery motors will have an antenna cord out the end of the motor.

How to get started using your Motorized Roller Shade System with a DC Motor:

- Please read all the instructions provided with your tubular motor.
- Your motor will be shipped in “sleep mode” and must be woken up before using.
- You will need a remote control or a smart phone to set up and control your tubular motor.
- Keep the cords and any loose fabric away from the rotating parts of the roller shade while in use.
- Only use power options for your motor that are available through Rowley Company.
- DC motors will have a power cord and an antenna cord out the end of the motor.