

# MANUAL EZ RISE CORDLESS ROMAN SPRING SHADE SYSTEMS

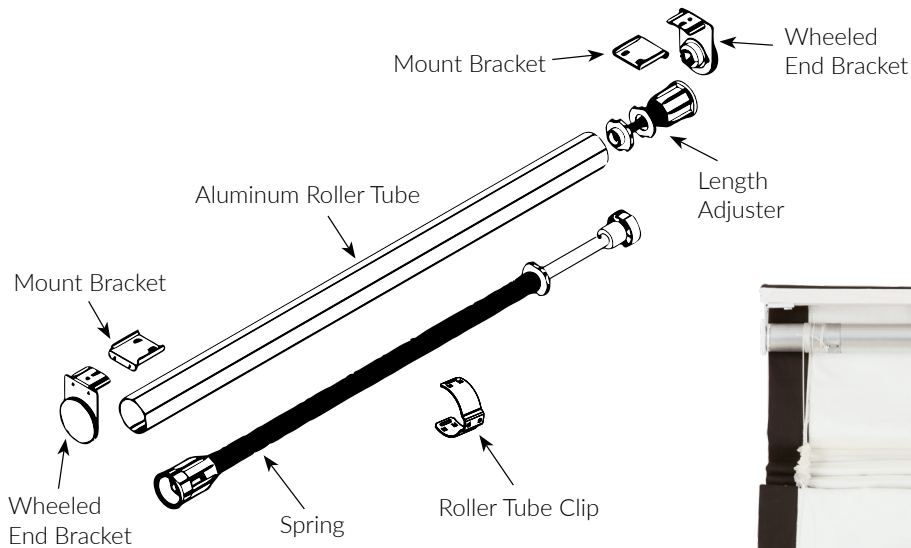

## 1 – CHOOSE YOUR SHADE QUANTITY

Let our in-house experts know how many shades to assemble.

## 2 – CHOOSE YOUR SHADE WEIGHT & SPRING SIZE

Your shade weight determines spring size. Refer to the chart on page 186 in the 2025 Rowley Catalog.

## 3 – CHOOSE YOUR BRACKET TYPE & COLOR

Select Slotted (outside mount) or Wheeled (inside or outside mount), in White or Black.

## 4 – CHOOSE YOUR LIFTING MATERIAL

Select from Encased Lift Cord Tube or 6" Lift Band.

*\*Builds do not include Lift Cord or Lift Band. Remember to order Lift Cord or Lift Band.*

## 5 – CHOOSE YOUR SHADE DIMENSIONS

Check maximum size for shade weight from step 2. Maximum Width is 96". Maximum Length is 96". Minimum Width is 36". Dustboard Size is ¾" x 2 ½".



## 6 – CHOOSE YOUR LIFTING MATERIAL SPECIFICATIONS

Select the Number of Columns of lifting material on the shade. Indicate the distances between each column. Minimum spacing for Lift Band = 8"; Encased Lift Cord = 7".

## 7 – CHOOSE YOUR SHADE MOUNT

Select Front / Standard or Reverse.

# MANUAL EZ RISE CORDLESS ROMAN SPRING SHADE SYSTEM

REV April 1, 2025

Encased Lift Cord or 6" Lift Band | BUILDS DO NOT INCLUDE LIFT CORD OR LIFT BAND  
12" cords are only included to show the correct routing; Systems are built with 1 1/2" diameter roller tube

ACCOUNT # \_\_\_\_\_

Company _____	Contact _____	Date _____
Street Address _____		Person to contact with technical questions _____
City _____	State _____	Zip _____ PO _____ Phone _____
Email _____ (required for shipping confirmation)		
Ship to (if different from above) _____		Attn _____
Street Address _____		City _____ State _____ Zip _____

**PLEASE COMPLETE ITEMS 1 THROUGH 9.**

*For assistance, call Customer Service at 800.343.4542 or 704.866.0650.  
Email completed form to sales@rowleycompany.com.*

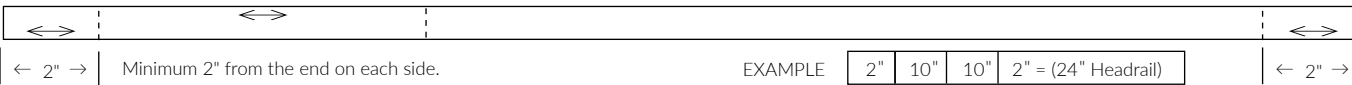
1 Total number of shades to be made to these specifications	→	<input style="width: 100%;" type="text"/>	(Use another order form for shades with different specifications)
2 SHADE WEIGHT: Include the weight of the fabric, lining, stiffeners & bottom weights.	<input style="width: 100%;" type="text"/>	<input type="checkbox"/> 3/8" Solid Steel Rod	<input type="checkbox"/> 2" Flat Weight Bar
3 SPRING SIZE	<input type="checkbox"/> RS18 <input type="checkbox"/> RS20 <input type="checkbox"/> RS22 <input type="checkbox"/> RS24 <input type="checkbox"/> RS26 <input type="checkbox"/> RS28 * Please reference the chart on <a href="#">page 186 of the 2025 Rowley Catalog</a> .		
4 TYPE OF BRACKETS	<input type="checkbox"/> SLOTTED (use for outside mount) <input type="checkbox"/> WHEELED (use for inside or outside mount)		
5 TYPE OF LIFTING MATERIAL	<input type="checkbox"/> ENCASED LIFT CORD TUBE <input type="checkbox"/> 6" LIFT BAND		
6 EXACT SHADE DIMENSIONS in inches. We do not make any additional deductions. <b>We do not accept EZ Rise Roman Spring Shade orders wider than 96" or taller than 96". Minimum width is 36".</b>	WIDTH 	Dustboard size 3/4" x 2 1/2"	
7 NUMBER OF COLUMNS OF LIFTING MATERIAL. INDICATE THE DISTANCES BETWEEN EACH COLUMN OF LIFTING MATERIAL ON THE SHADE. Minimum spacing for Lift Band = 8"; Encased Lift Cord = 7". Your headrail will be built according to the measurements you provide on the chart below. Your sketch doesn't have to be to scale, but THE NUMBERS MUST BE ACCURATE to the nearest 1/8". Draw vertical lines to show the columns of Encased Lift Cord. Be sure to include every column, including those close to the edges of the headrail. The first two columns are sketched for you. Write the measurements to indicate the distance between each column of Encased Lift Cord and the next. CHECK THAT THESE MEASUREMENTS ADD UP TO THE EXACT SHADE WIDTH IN ITEM 6.	<input style="width: 100%;" type="text"/> COLUMNS		
			
8 SHADE MOUNTING: Shades are typically mounted over the front of the operating system. Indicate if you plan to mount to the back of the operating system by checking the box. No additional charge.	<input type="checkbox"/> FRONT MOUNT STANDARD <input type="checkbox"/> REVERSE MOUNT		
9 READ THE TERMS OF SALE on the Custom Solutions Payment Form on <a href="#">page 3</a> , sign and submit along with your signed forms.			

\*Builds do not include Lift Cord or Lift Band. Remember to order Lift Cord or Lift Band.

SHIPPING » [Flat Rate Shipping Program](#) Lengths over 8' will ship truck and incur an oversized  fee.



 Rowley® Company  
230 Meek Road / Gastonia / NC / 28056  
Phone » toll-free 800-343-4542 or local 704-866-0650  
© 2025 Rowley® Company, LLC

\_\_\_\_\_  
Signature of purchaser / cardholder

\_\_\_\_\_  
Date

# PAYMENT FORM

ACCOUNT # \_\_\_\_\_

To place a Custom Solutions Shade System or Drapery Hardware System order, you must complete and sign the Payment Form along with the applicable system build form. You may submit your completed forms via email to Sales@RowleyCompany.com.

For Order Forms, visit [RowleyCompany.com/CustomSolutions](http://RowleyCompany.com/CustomSolutions)

<input type="radio"/> <b>OVERNIGHT SHIPPING</b> (additional freight will apply)	SHIPPING » <a href="#">Flat Rate Shipping Program</a> Lengths over 8' will ship truck and incur an oversized  fee. Splicing options for overlength sizes and alternative freight quotes available.								
SELECT ONE <input type="radio"/> <input type="radio"/> <input type="radio"/> <input type="radio"/>	EXPIRATION DATE <table border="1" style="width: 100%; height: 20px; border-collapse: collapse;"> <tr> <td style="width: 25%;"></td> <td style="width: 25%;"></td> <td style="width: 25%;"></td> <td style="width: 25%;"></td> </tr> </table>								
CREDIT CARD # - LAST 4 DIGITS <table border="1" style="width: 100%; height: 20px; border-collapse: collapse;"> <tr> <td style="width: 25%;"></td> <td style="width: 25%;"></td> <td style="width: 25%;"></td> <td style="width: 25%;"></td> </tr> </table>					SECURITY CODE <table border="1" style="width: 100%; height: 20px; border-collapse: collapse;"> <tr> <td style="width: 25%;"></td> <td style="width: 25%;"></td> <td style="width: 25%;"></td> <td style="width: 25%;"></td> </tr> </table>				
I authorize Rowley® Company to charge the credit card above for all of my orders submitted to Rowley® Company. I have read, understood and agree to the Terms of Sale on this payment form.									
<table border="1" style="width: 100%; border-collapse: collapse;"> <tr> <td style="text-align: center; padding: 5px;">                     Credit Card Billing Address (if different than ship to address)                 </td> </tr> <tr> <td style="padding: 5px;">                     _____                      Complete Name of Card Holder                 </td> </tr> <tr> <td style="padding: 5px;">                     _____                      Street Address                 </td> </tr> <tr> <td style="padding: 5px;">                     _____      _____      _____                      City                                  State                  Zip                 </td> </tr> <tr> <td style="padding: 5px;">                     _____                      Phone                 </td> </tr> <tr> <td style="padding: 5px;">                     _____                      Email                 </td> </tr> </table>	Credit Card Billing Address (if different than ship to address)	_____ Complete Name of Card Holder	_____ Street Address	_____      _____      _____ City                                  State                  Zip	_____ Phone	_____ Email	<table border="1" style="width: 100%; border-collapse: collapse;"> <tr> <td style="width: 30px; height: 30px; border: 1px solid black;"></td> <td style="padding: 5px;">                     Ship and apply to my pre-approved Net 30 account.                      Account # _____                 </td> </tr> </table> <p style="font-size: small; margin-top: 10px;">                     The price of the custom build includes all parts, labor and packaging, but does not include sales tax where applicable or shipping charges, for which the receiver is responsible. All orders will ship within five business days from confirmation of order with satisfactory payment arrangements. Automated® Traverse orders will ship within 10 - 15 business days. For commercial orders, request a quote with timeline. Terms: Net 30 days to pre-approved accounts only or credit card. Prices, design and availability are subject to change or withdrawal without notice.                 </p>		Ship and apply to my pre-approved Net 30 account. Account # _____
Credit Card Billing Address (if different than ship to address)									
_____ Complete Name of Card Holder									
_____ Street Address									
_____      _____      _____ City                                  State                  Zip									
_____ Phone									
_____ Email									
	Ship and apply to my pre-approved Net 30 account. Account # _____								
_____ Signature of purchaser / cardholder	_____ Date								

## TERMS OF SALE      WARRANTIES BY ROWLEY® COMPANY

Rowley® Company agrees to repair or replace, free of charge, any Custom Solutions Shade or Track System that due to faulty parts or workmanship in the assembled Shade or Track System is returned freight pre-paid to Rowley® Company within ninety (90) days of delivery. The parts in the system are covered by a ten year warranty. These warranties do not cover systems that have been subjected to abuse. The Slim Drapery Motor is covered by a 5 year warranty.

Orders for Custom Solutions Shade or Track Systems are not cancelable and cannot be altered. Custom Solutions Shade or Track Systems are not returnable for any reason except warranty repair, as described above. The buyer verifies that all sizes and other specifications are correct. A Custom Solutions Shade or Track System will be custom-built to the size and other specifications written on the system order form. Rowley® Company will repair or replace without charge any Custom Solutions Shade or Track System that is not made correctly to those specifications. **THE CUSTOMER WILL BE CHARGED FOR ANY REPAIRS OR REPLACEMENT NECESSITATED BY AN ERROR IN THE MEASUREMENT OR OTHER SPECIFICATIONS.**

**OWNERSHIP:** All selected shipping preferences are F.O.B. shipping point from any Rowley® location; the buyer owns the shipment as soon as it leaves the Rowley® Company loading dock. In the event of damaged shipment, the buyer must accept the shipment and place a claim with the carrier. Prices quoted include all parts, labor and packaging for all Custom Solutions Shade or Track Systems. The buyer is responsible for shipping costs.