

**PRO-FORM®**

**CARBON HIIT H7**

proform.com

Model No. PFEL09920.0

Serial No. \_\_\_\_\_

Write the serial number in the space above for reference.

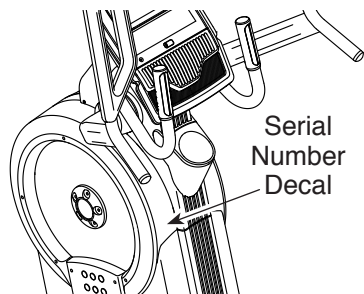

## ACTIVATE YOUR WARRANTY

To register your product and activate your warranty today, go to [my.proform.com](http://my.proform.com).

## CUSTOMER CARE

For service at any time, go to [support.proform.com](http://support.proform.com).

Or call 1-888-533-1333  
Mon.–Fri. 6 a.m.–6 p.m. MT  
Sat. 8 a.m.–12 p.m. MT

Please do not contact the store.

## ⚠ CAUTION

Read all precautions and instructions in this manual before using this equipment. Keep this manual for future reference.

# USER'S MANUAL

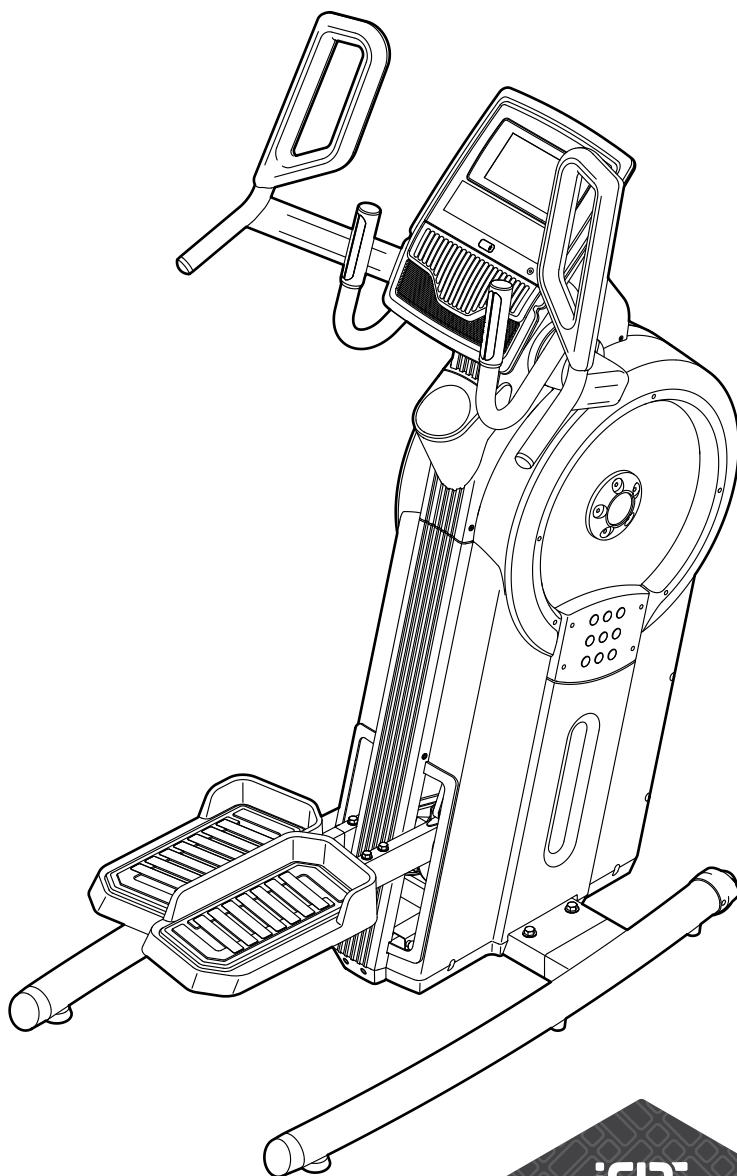

# TABLE OF CONTENTS

WARNING DECAL PLACEMENT ..... 2

IMPORTANT PRECAUTIONS ..... 3

BEFORE YOU BEGIN ..... 5

PART IDENTIFICATION CHART ..... 6

ASSEMBLY ..... 7

HOW TO USE THE TRAINER ..... 13

HOW TO USE THE CONSOLE ..... 15

FCC INFORMATION ..... 26

MAINTENANCE AND TROUBLESHOOTING ..... 27

EXERCISE GUIDELINES ..... 29

PART LIST ..... 32

EXPLODED DRAWING ..... 34

ORDERING REPLACEMENT PARTS ..... Back Cover

LIMITED WARRANTY ..... Back Cover

## WARNING DECAL PLACEMENT

This drawing shows the location(s) of the warning decal(s). **If a decal is missing or illegible, see the front cover of this manual and request a free replacement decal. Apply the decal in the location shown.** Note: The decal(s) may not be shown at actual size.

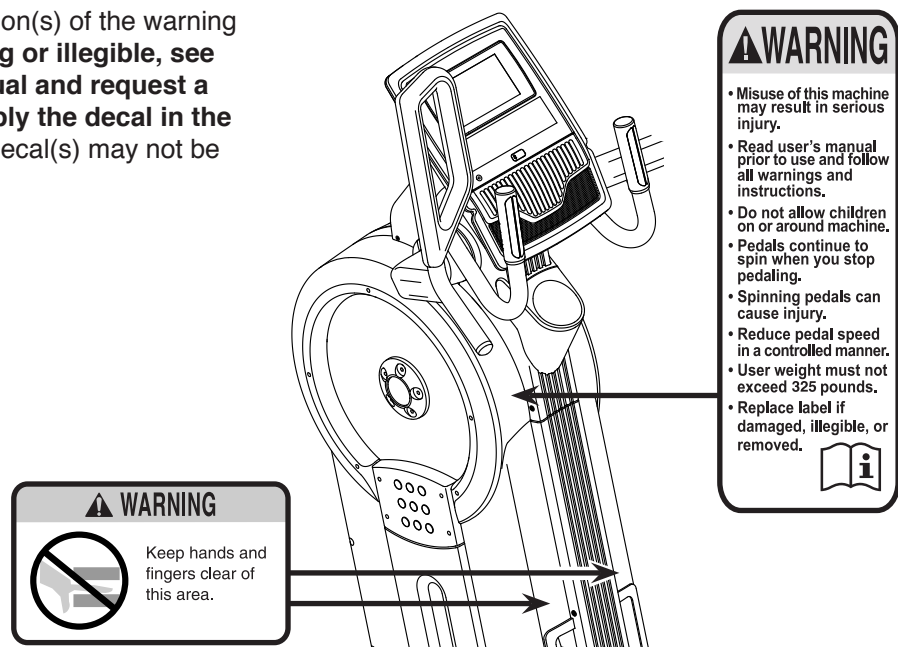

PROFORM and IFIT are registered trademarks of ICON Health & Fitness, Inc. The Bluetooth® word mark and logos are registered trademarks of Bluetooth SIG, Inc. and are used under license. Google Maps is a trademark of Google LLC. Wi-Fi is a registered trademark of Wi-Fi Alliance. WPA and WPA2 are trademarks of Wi-Fi Alliance.

---

# IMPORTANT PRECAUTIONS

**⚠ WARNING:** To reduce the risk of serious injury, read all important precautions and instructions in this manual and all warnings on the trainer before using the trainer. ICON assumes no responsibility for personal injury or property damage sustained by or through the use of this product.

1. It is the responsibility of the owner to ensure that all users of the trainer are adequately informed of all precautions.
2. Before beginning any exercise program, consult your physician. This is especially important for persons over age 35 or persons with pre-existing health problems.
3. The trainer is not intended for use by persons with reduced physical, sensory, or mental capabilities or lack of experience and knowledge, unless they are given supervision or instruction about use of the trainer by someone responsible for their safety.
4. Use the trainer only as described in this manual.
5. The trainer is intended for home use only. Do not use the trainer in a commercial, rental, or institutional setting.
6. Keep the trainer indoors, away from moisture and dust. Do not put the trainer in a garage or covered patio, or near water.
7. Place the trainer on a level surface, with at least 3 ft. (0.9 m) of clearance in the front and rear of the trainer and 2 ft. (0.6 m) on each side. To protect the floor or carpet from damage, place a mat under the trainer.
8. Inspect and properly tighten all parts each time the trainer is used. Replace any worn parts immediately.
9. Keep children under age 16 and pets away from the trainer at all times.
10. The trainer should not be used by persons weighing more than 325 lbs. (147 kg).
11. Wear appropriate clothes while exercising; do not wear loose clothes that could become caught on the trainer. Always wear athletic shoes for foot protection while exercising.
12. Hold the handlebars or the upper body arms when mounting, dismounting, or using the trainer. Before mounting or dismounting, bring the pedals to a stop with the pedal on the mounting or dismounting side in its lowest position.
13. The heart rate monitor is not a medical device. Various factors may affect the accuracy of heart rate readings. The heart rate monitor is intended only as an exercise aid in determining heart rate trends in general.
14. The trainer does not have a freewheel; the pedals will continue to move until the flywheel stops. Reduce your pedaling speed in a controlled way.
15. Keep your back straight while using the trainer; do not arch your back.
16. Over exercising may result in serious injury or death. If you feel faint, if you become short of breath, or if you experience pain while exercising, stop immediately and cool down.

# PROTECT

YOUR FITNESS EQUIPMENT  
WITH AN EXTENDED SERVICE PLAN

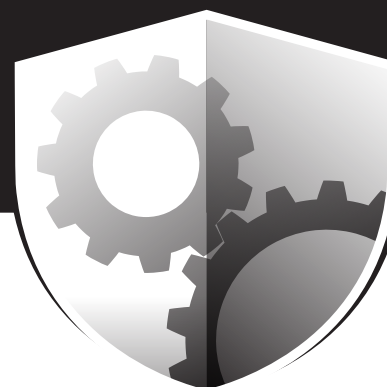

Your new fitness equipment is not an ordinary purchase; it is an investment in your health and well being for years to come.

As the leading provider of manufacturer's extended service plans, ICON strives to protect your equipment and your future.

Please review the following service plans and find one that best fits your needs.

## PREVENTIVE MAINTENANCE SERVICE PLANS

Equipment Price	3-Year Plan	5-Year Plan
\$0.00 to \$1000.00	\$199.99	\$289.99
\$1001.00 to \$1500.00	\$259.99	\$379.99
\$1501.00 to \$2500.00	\$339.99	\$489.99
(Bikes/Systems Only) \$0.00 to \$2500.00	\$139.99	NA

Features:

- Includes an annual preventive maintenance and performance check at your convenience
- Unlimited in-home repairs; no shipping required
- Covers parts and labor on all manufacturer's defects, as well as wear and tear on parts
- Up to 5 years of coverage available

## STANDARD SERVICE PLANS

Equipment Price	1-Year Plan	2-Year Plan	3-Year Plan
\$0.00 to \$300.00	\$29.99	\$39.99	\$59.99
\$301.00 to \$1000.00	\$89.99	\$119.99	\$149.99
\$1001.00 to \$2000.00	\$109.99	\$139.99	\$179.99
\$2001.00 to \$3000.00	\$179.99	\$209.99	\$239.99

Features:

- Unlimited in-home repairs; no shipping required
- Covers parts and labor on all manufacturer's defects, as well as wear and tear on parts
- Up to 3 years of coverage available

To protect your fitness equipment today, please  
call Customer Care at **1-800-677-3838.**  
Or, visit us online at **www.utserv.com.**



# BEFORE YOU BEGIN

Thank you for selecting the revolutionary PROFORM® CARBON HIIT H7 trainer. The CARBON HIIT H7 trainer provides an impressive selection of features designed to make your workouts at home more effective and enjoyable.

**For your benefit, read this manual carefully before you use the trainer.** If you have questions after

reading this manual, please see the front cover of this manual. To help us assist you, note the product model number and serial number before contacting us. The model number and the location of the serial number decal are shown on the front cover of this manual.

Before reading further, please familiarize yourself with the parts that are labeled in the drawing below.

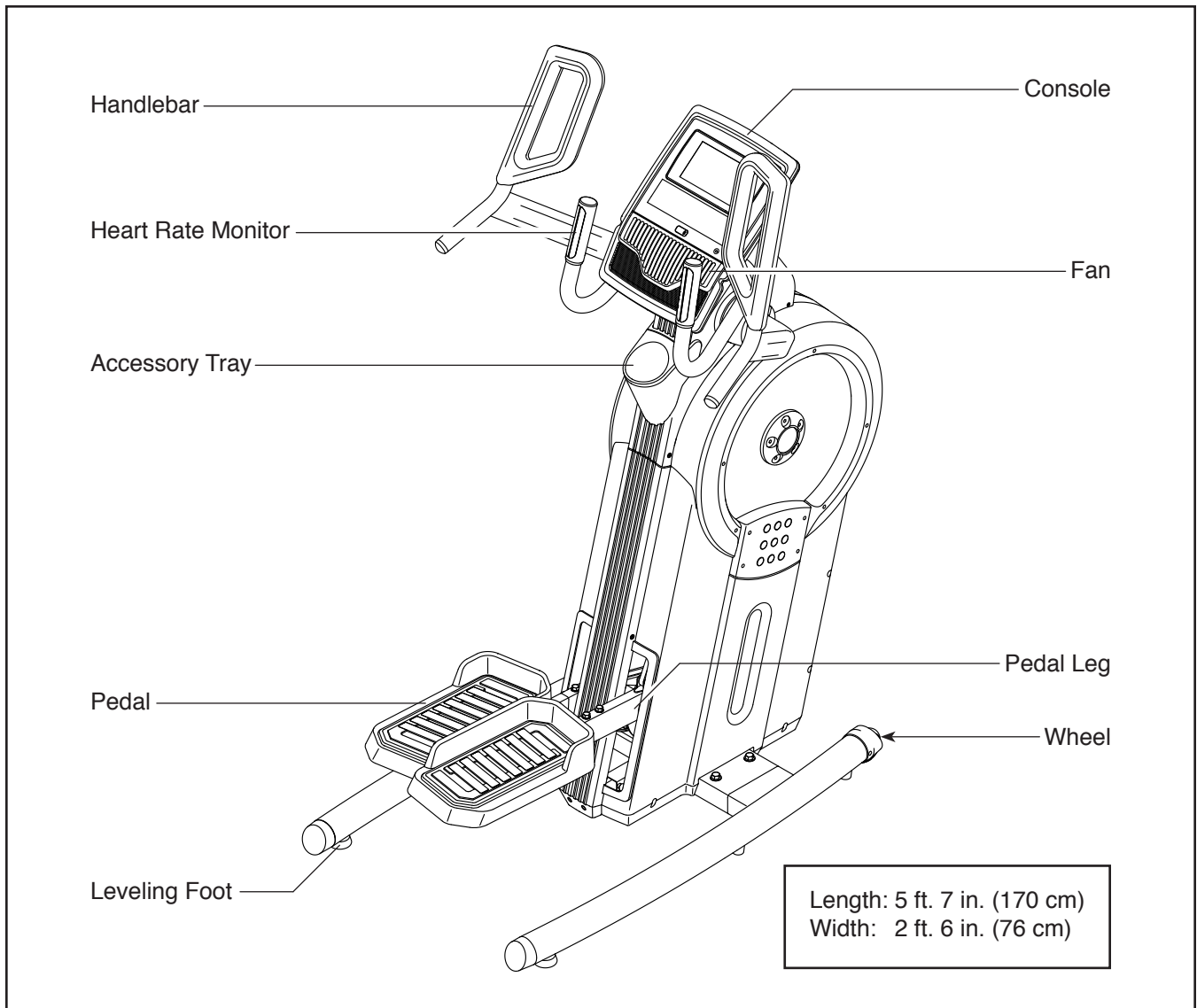

# PART IDENTIFICATION CHART

Use the drawings below to identify the small parts needed for assembly. The number in parentheses below each drawing is the key number of the part, from the PART LIST near the end of this manual. The number following the key number is the quantity needed for assembly. **Note: If a part is not in the hardware kit, check to see if it has been preassembled. Extra parts may be included.**

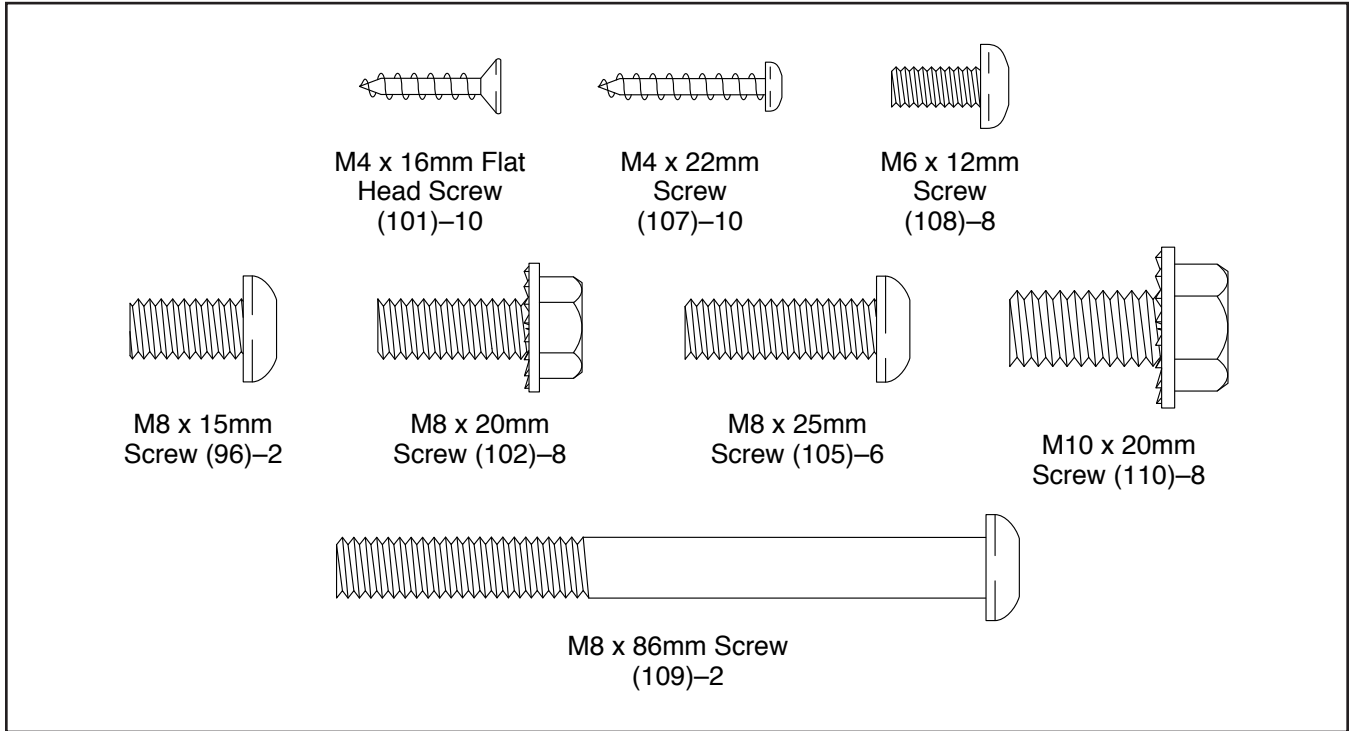

# ASSEMBLY

- To hire an authorized service technician to assemble this product, call 1-800-445-2480.
- Assembly requires two persons.
- Place all parts in a cleared area and remove the packing materials. Do not dispose of the packing materials until you finish all assembly steps.
- Left parts are marked “L” or “Left” and right parts are marked “R” or “Right.”

- To identify small parts, see page 6.
- In addition to the included tool(s), assembly requires the following tools:

one Phillips screwdriver 

one adjustable wrench 

Assembly may be easier if you have your own set of wrenches. To avoid damaging parts, do not use power tools.

1. **Go to [my.proform.com](http://my.proform.com) on your computer and register your product.**

- documents your ownership
- activates your warranty
- ensures priority customer support if assistance is ever needed

Note: If you do not have internet access, call Customer Care (see the front cover of this manual) and register your product.

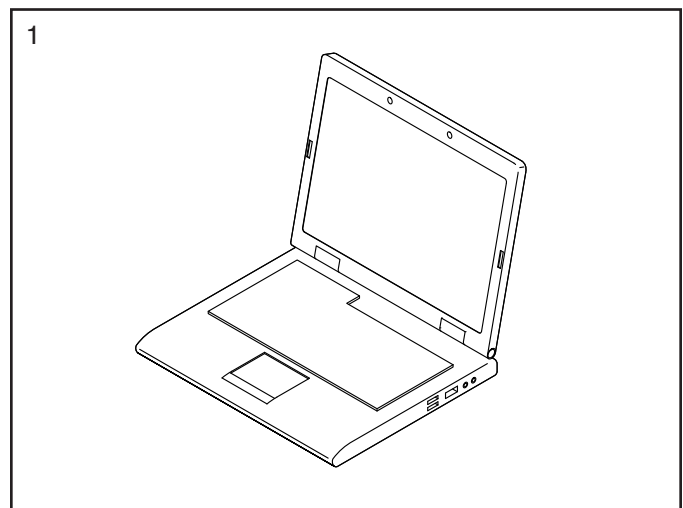

2. Identify the Right and Left Stabilizers (8, 9) and orient them as shown.

Have a second person hold the Frame (1) and tip it to the left. **IMPORTANT: Be careful not to damage the Shields (50, 51).**

Attach the Right Stabilizer (8) to the Frame (1) with four M10 x 20mm Screws (110); **start all the Screws, and then tighten them.**  
Note: Disregard the two unthreaded holes in the underside of the Frame.

**IMPORTANT: Make sure to tighten the M10 x 20mm Screws (110) firmly and completely.**

Have the second person lower the Frame (1) to the floor. **IMPORTANT: Be careful not to damage the Shields (50, 51).**

**Attach the Left Stabilizer (9) in the same way.**

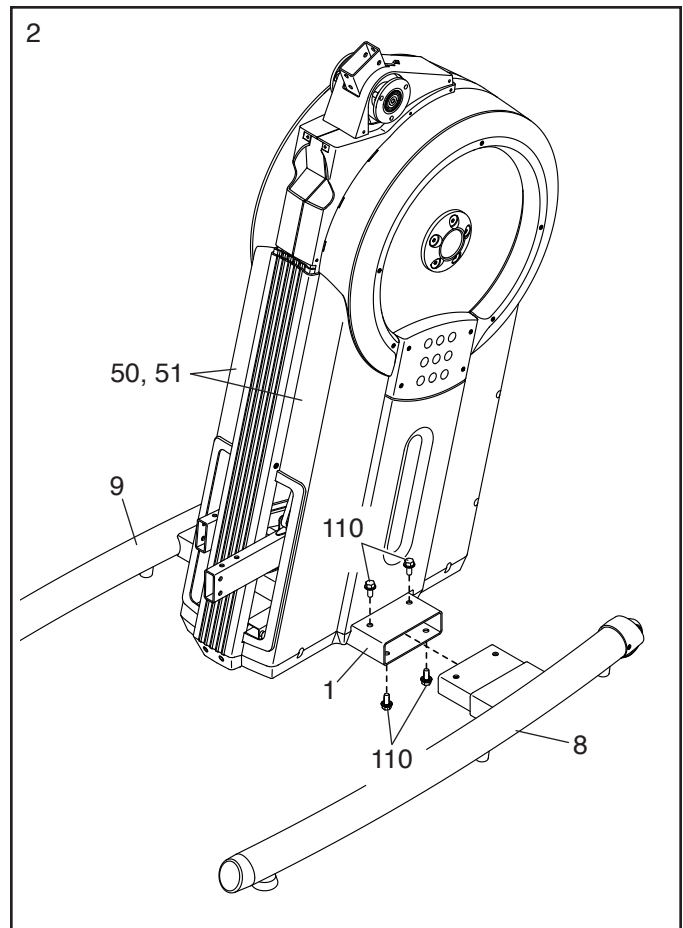

3. Identify the Right and Left Pedal Bases (2, 3) and the Right and Left Pedals (22, 23), and orient them as shown.

Attach the Right Pedal (22) to the Right Pedal Base (2) with four M6 x 12mm Screws (108); **start all the Screws, and then tighten them.**

**Attach the Left Pedal (23) to the Left Pedal Base (3) in the same way.**

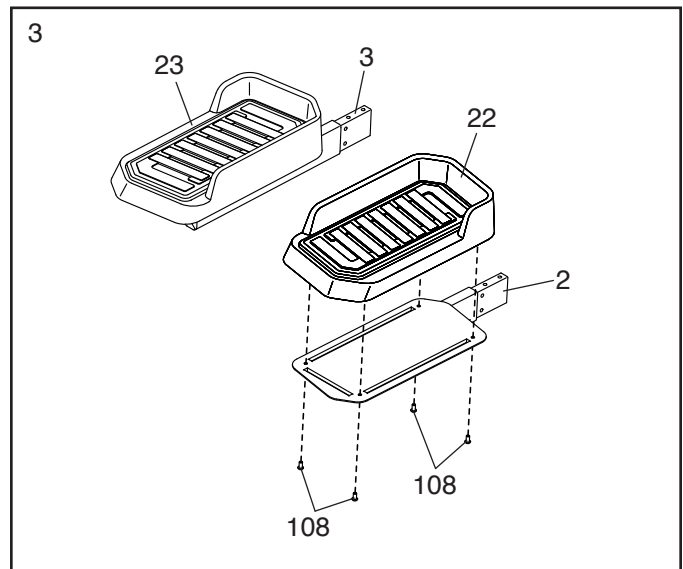



4. Attach the Right Pedal Base (2) to the Right Pedal Leg (24) with four M8 x 20mm Screws (102); **start all the Screws, and then tighten them.**

**Attach the Left Pedal Base (3) to the Left Pedal Leg (25) in the same way.**

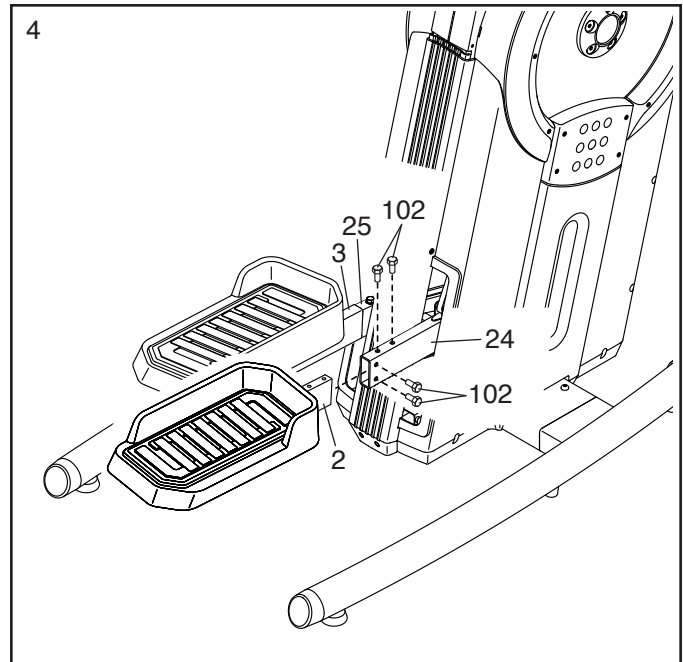

5. Press the Rear Cover (53) onto the Left and Right Shields (50, 51).

Attach the Rear Cover (53) with four M4 x 16mm Flat Head Screws (101); **start all the Flat Head Screws, and then tighten them.**

Then, insert the Accessory Tray (18) into the Rear Cover (53).

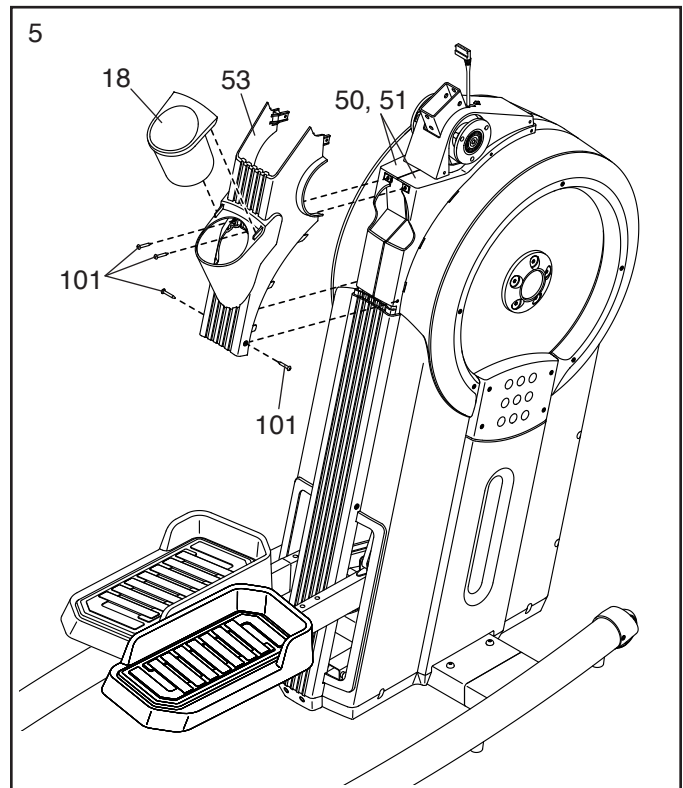

6. **See the upper drawing.** With the help of a second person, orient the Console (5), the Console Cover (7), and the Console Bracket (4) as shown. Then, route the wires (A) on the Console through the Console Cover and the Console Bracket.

**See the lower drawing. Tip: Avoid pinching the wires.** Attach the Console (5) and the Console Cover (7) to the Console Bracket (4) with four M4 x 22mm Screws (107); **start all the Screws, and then tighten them.**

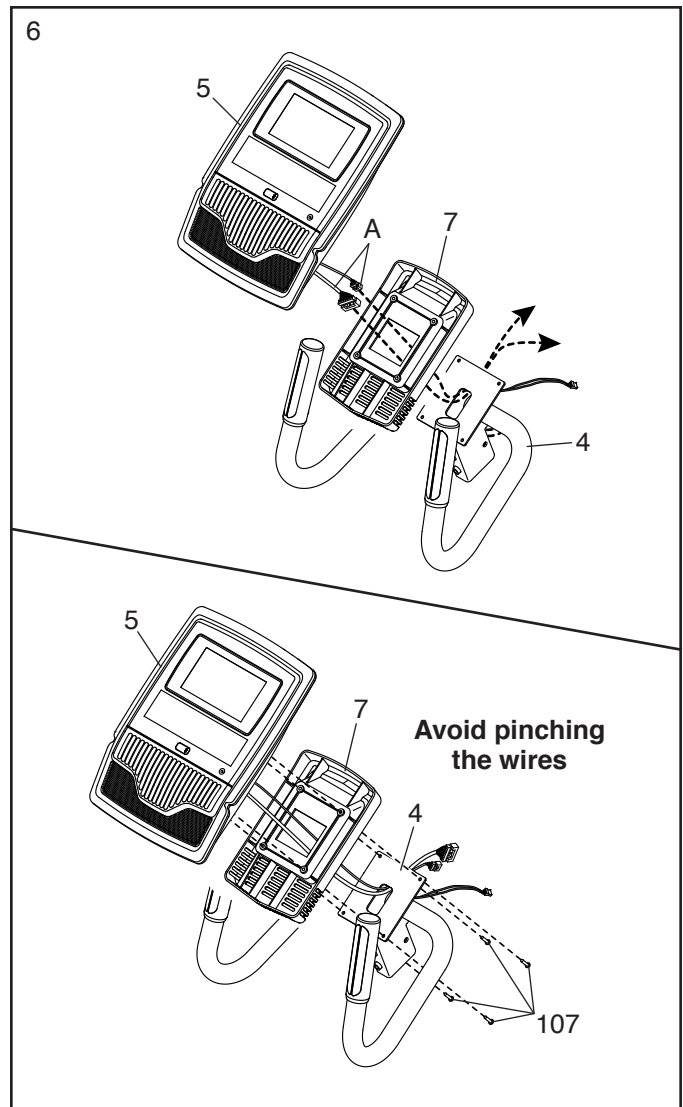

7. While a second person holds the Console Bracket (4) near the Frame (1), connect the wires on the Console (5) to the Main Wire (115) and to the Pulse Wire (117).

**Tip: Avoid pinching the wires.** Attach the Console Bracket (4) to the Frame (1) with two M8 x 86mm Screws (109) and two M8 x 15mm Screws (96); **start all the Screws, and then tighten them.**

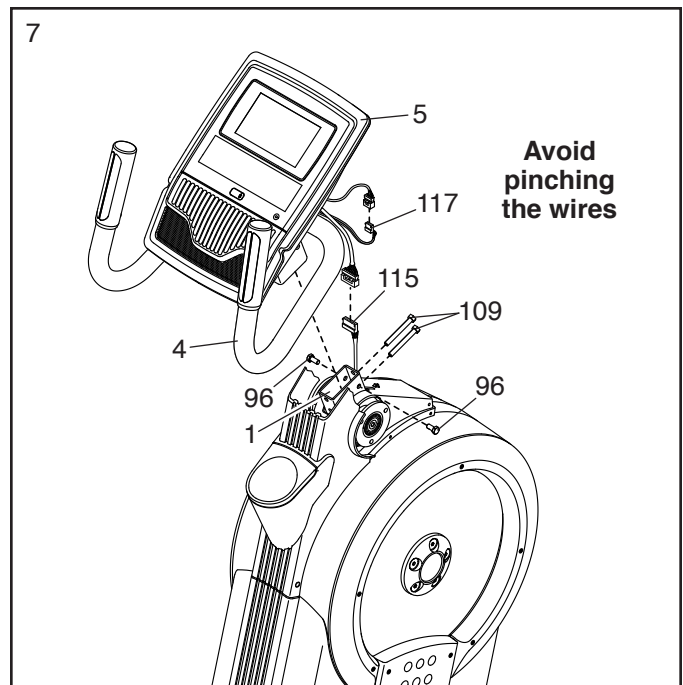

8. Identify the Right and Left Handlebars (10, 11).

**Make sure that the Pedals (22, 23) are level.** Attach the Right Handlebar (10) to the Right Handlebar Arm (15) with three M8 x 25mm Screws (105); **start all the Screws, and then tighten them.** **Tip: It may be helpful to rotate the Right Handlebar for better access to tighten the Screws.**

**Attach the Left Handlebar (11) in the same way.**

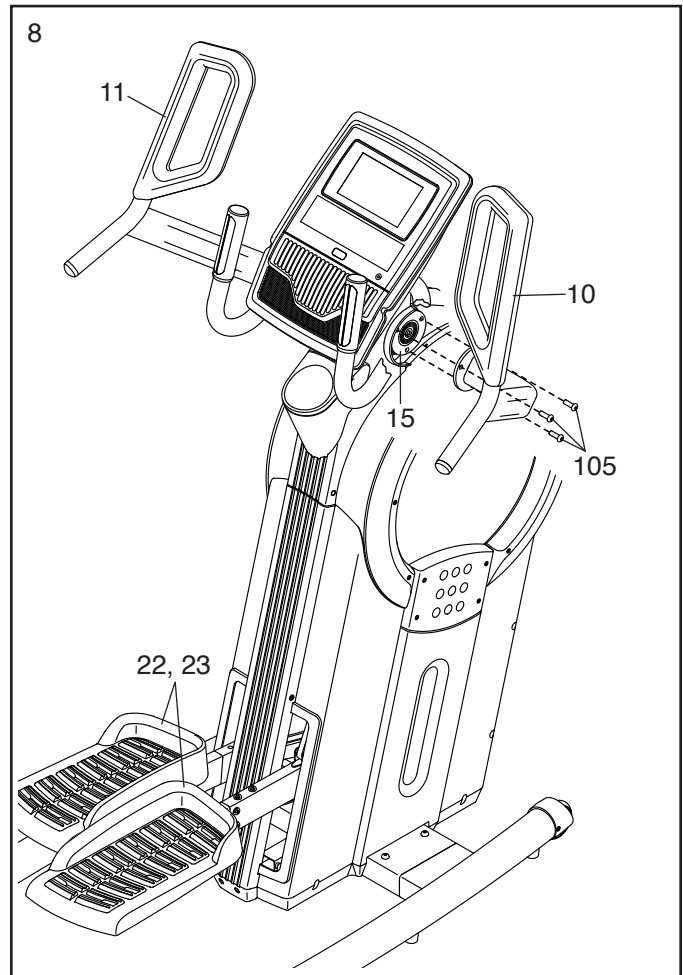

9. Identify the Rear and Front Pivot Covers (65, 66).

Press a set of Rear and Front Pivot Covers (65, 66) together around the Right Handlebar (10) near the bend (B). Then, attach them to each other with two M4 x 22mm Screws (107).

**See the inset drawing.** Slide the Rear and Front Pivot Covers (65, 66) toward the Shield Cover (12). Attach the Front Pivot Cover to the Right Handlebar (10) with an M4 x 22mm Screw (107).

**Repeat this step on the other side of the trainer.**

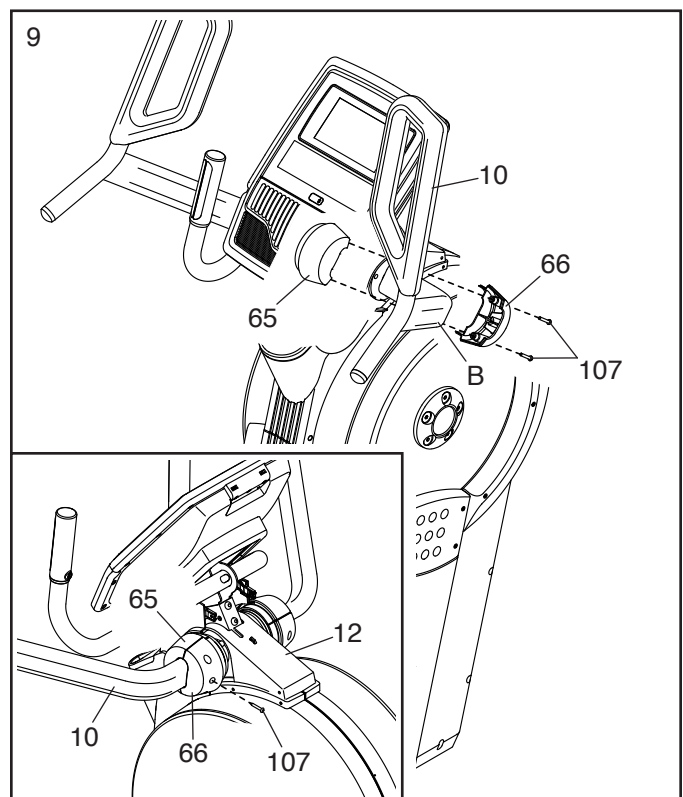

10. Attach the Front Cover (52) to the Left and Right Shields (50, 51) with six M4 x 16mm Flat Head Screws (101); **start all the Flat Head Screws, and then tighten them.**

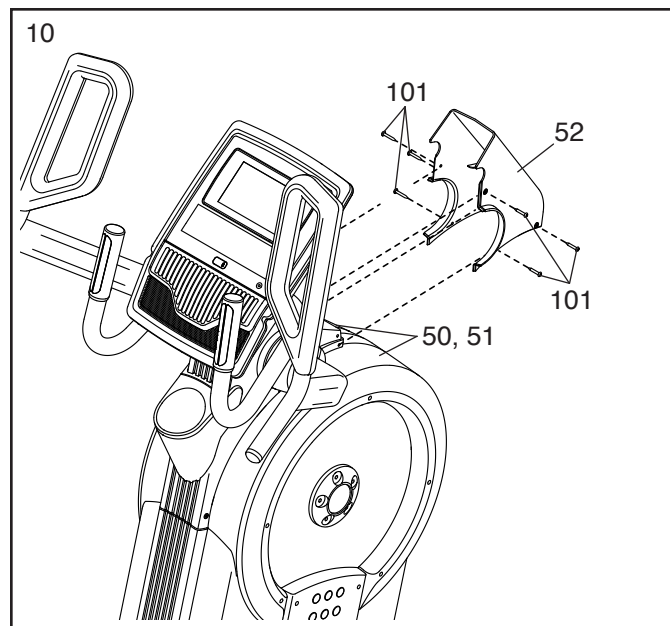

11. Plug the Power Adapter (118) into the receptacle on the front of the trainer.

Note: To plug the Power Adapter (118) into an outlet, see HOW TO PLUG IN THE POWER ADAPTER on page 13.

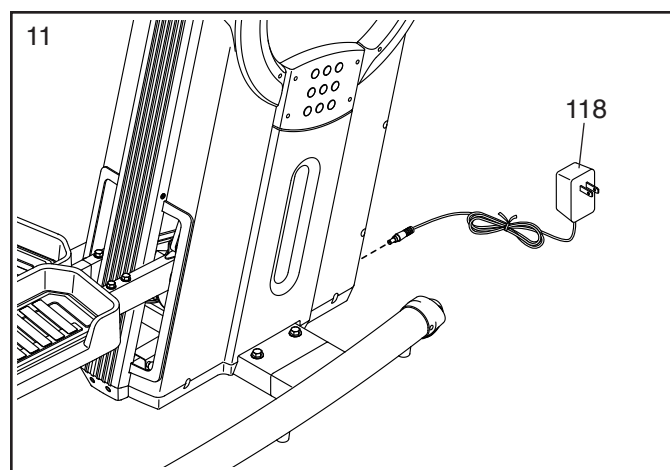

12. **Make sure that all parts are properly tightened.** Extra parts may be included. Place a mat beneath the trainer to protect the floor.

# HOW TO USE THE TRAINER

## HOW TO PLUG IN THE POWER ADAPTER

**IMPORTANT:** If the trainer has been exposed to cold temperatures, allow it to warm to room temperature before you plug in the power adapter (A). If you do not do this, you may damage the console displays or other electronic components.

Plug the power adapter (A) into the receptacle on the front of the trainer. Then, plug the power adapter into an appropriate outlet that is properly installed in accordance with all local codes and ordinances.

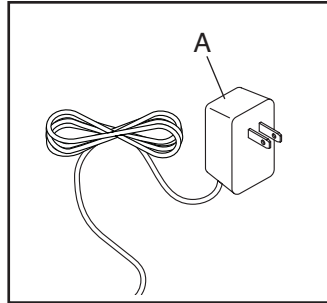

## HOW TO MOVE THE TRAINER

**Due to the size and weight of the trainer, moving it requires two persons.** Stand in front of the trainer, hold the console bracket (B), and place one foot against one of the wheels (C). Have a second person help you pull on the console bracket until the trainer will roll on the wheels. Carefully move the trainer to the desired location, and then lower it to the floor.

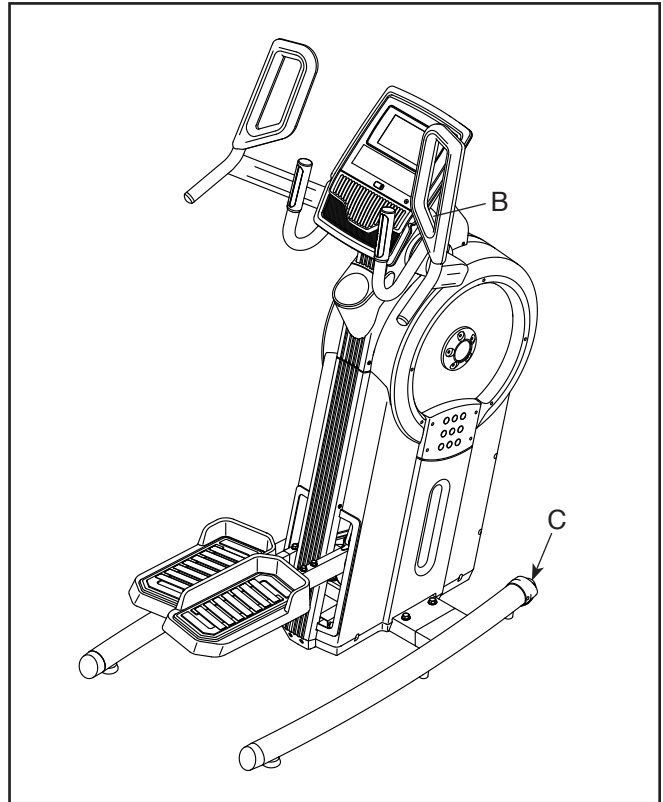

## HOW TO EXERCISE ON THE TRAINER

To mount the trainer, hold the handlebars (D) or the pulse grips (E) and step onto the pedal (F) that is in the lower position. Then, step onto the other pedal. Push the pedals until they begin to move with a continuous motion. **Note: The pedals can turn in either direction. It is recommended that you turn the pedals in the direction shown by the arrow; however, for variety, you can turn the pedals in the opposite direction.**

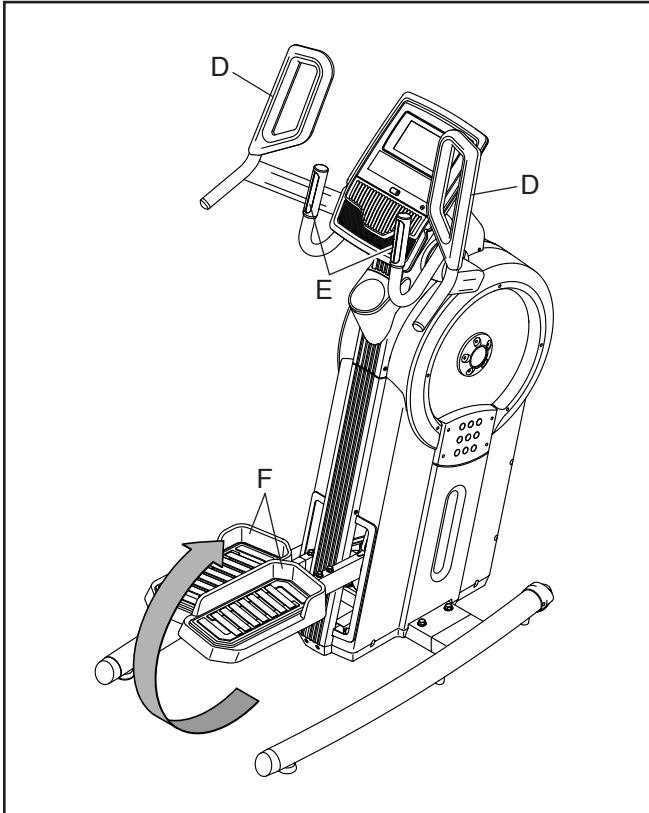

To dismount the trainer, wait until the pedals (F) come to a complete stop. **Note: The trainer does not have a free wheel; the pedals will continue to move until the flywheel stops.** When the pedals are stationary, step off the higher pedal first. Then, step off the lower pedal.

## HOW TO LEVEL THE TRAINER

If the trainer rocks slightly on your floor during use, turn one or both of the leveling feet (G) beneath the stabilizers until the rocking motion is eliminated.

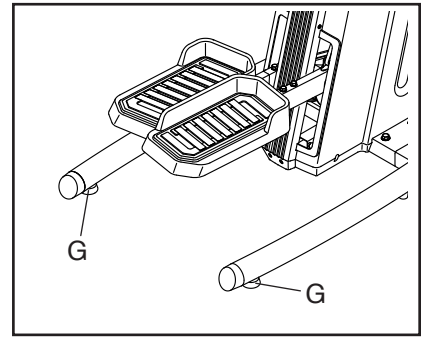

## THE OPTIONAL TABLET HOLDER

The optional tablet holder (H) will hold your tablet securely in place and enable you to use your tablet while you exercise. The optional tablet holder is designed for use with most full-size tablets.

**To purchase a tablet holder, please see the front cover of this manual.**

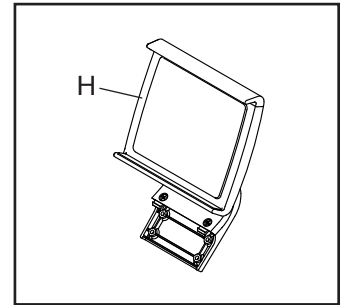

# HOW TO USE THE CONSOLE

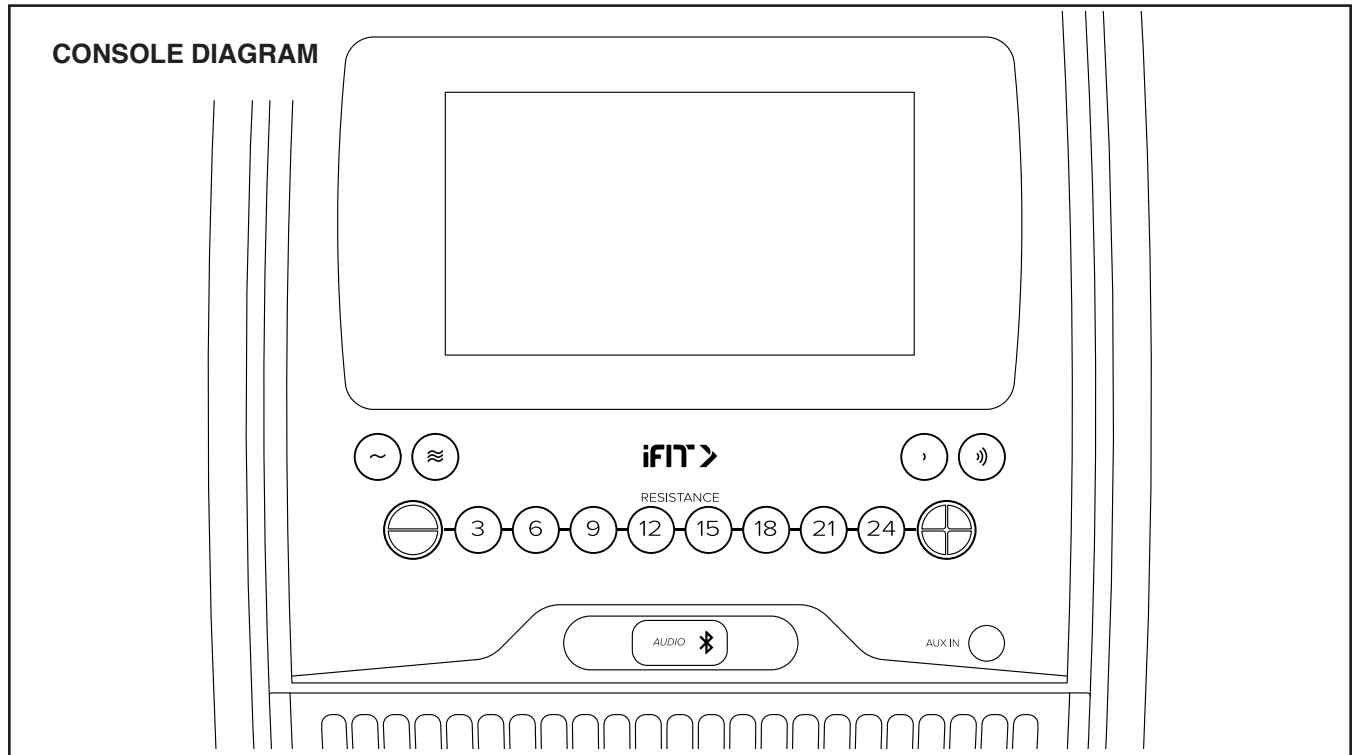

## FEATURES OF THE CONSOLE

The advanced console offers an array of features designed to make your workouts more effective and enjoyable.

The console features wireless technology that enables the console to connect to iFit. With iFit, you can access a large and varied workout library, create your own workouts, track your workout results, and access many other features.

In addition, the console features a selection of onboard workouts. Each workout automatically controls the resistance of the pedals as it guides you through an effective exercise session.

When you use the manual mode of the console, you can change the resistance of the pedals with the touch of a button.

While you exercise, the console will display continuous exercise feedback. You can even measure your heart rate using the handgrip heart rate monitor or a compatible heart rate monitor. **See page 25 for information about purchasing an optional chest heart rate monitor.**

You can also listen to your favorite workout music or audio books with the console sound system while you exercise.

**To turn on and turn off the console**, see page 16. **To learn how to use the touch screen**, see page 16. **To set up the console**, see page 17.

## HOW TO TURN ON THE CONSOLE

The included power adapter must be used to operate the trainer. See HOW TO PLUG IN THE POWER ADAPTER on page 13. When the power adapter is plugged in, touch the screen or press any button on the console to turn on the console.

## HOW TO TURN OFF THE CONSOLE

If the pedals do not move for several seconds, the console will pause.

If the pedals do not move for several minutes, the screen is not touched, and the buttons are not pressed, the console will turn off.

When you are finished exercising, unplug the power adapter. **IMPORTANT: If you do not do this, the electrical components on the trainer may wear prematurely.**

## HOW TO USE THE TOUCH SCREEN

The console features a tablet with a full-color touch screen. The following information will help you use the touch screen:

- The console functions similarly to other tablets. You can slide or flick your finger against the screen to move certain images on the screen, such as the displays in a workout.
- To type information into a text box, first touch the text box to view the keyboard. To use numbers or other characters on the keyboard, touch *?123*. To view more characters, touch *~[<*. Touch *?123* again to return to the number keyboard. To return to the letter keyboard, touch *ABC*. To use a capital character, touch the shift button (upward-facing arrow symbol). To use multiple capital characters, touch the shift button again. To return to the lowercase keyboard, touch the shift button a third time. To clear the last character, touch the clear button (backward-facing arrow with an X symbol).



## HOW TO SET UP THE CONSOLE

Before you use the trainer for the first time, set up the console.

### 1. Connect to your wireless network.

To use iFit workouts and to use several other features of the console, the console must be connected to a wireless network. Follow the prompts on the screen to connect the console to your wireless network.

### 2. Customize settings.

Follow the prompts on the screen to set the desired unit of measurement and your time zone.

Note: To change these settings later, see HOW TO CHANGE CONSOLE SETTINGS on page 23.

### 3. Log into or create an iFit account.

Follow the prompts on the screen to log into your iFit account or to create an iFit account.

### 4. Tour the console.

The first time you use the console, a tour presentation will guide you through the features of the console.

### 5. Check for firmware updates.

First, touch the menu button (three horizontal lines symbol), touch *Settings*, touch *Maintenance*, and then touch *Update*. The console will check for firmware updates. For more information, see HOW TO CHANGE CONSOLE SETTINGS on page 23.

The console is now ready for you to begin working out. The following pages explain the workouts and other features that the console offers.

To use the manual mode, see this page. To use a featured workout or an onboard workout, see page 19. To create a draw-your-own-map workout, see page 21. To use an iFit workout, see page 22.

To change console settings, see page 23. To connect to a wireless network, see page 24. To use the sound system, see page 25. To connect to the sound system with Bluetooth, see page 25.

Note: If there is a sheet of plastic on the screen, remove the plastic.

## HOW TO USE THE MANUAL MODE

### 1. Touch the screen or press any button on the console to turn on the console.

See HOW TO TURN ON THE CONSOLE on page 16. Note: It may take a few moments for the console to be ready for use.

### 2. Select the main menu.

When you turn on the console, the main menu will appear on the screen after the console boots up.

If you are in a workout, touch the screen and follow the prompts to end the workout and return to the main menu. If you are in the settings menus, touch the back button (arrow symbol) and then touch the close button (x symbol) to return to the main menu.

### 3. Change the resistance of the pedals as desired.

Touch *Manual Start* and begin pedaling.

You can change the resistance of the pedals by pressing one of the numbered Resistance buttons or by pressing the Resistance increase and decrease buttons.

Note: After you press a button, it will take a moment for the pedals to reach the selected resistance level.

#### 4. Follow your progress.

The console offers several display modes. The display mode that you select will determine which workout information is shown.

Drag upward on the screen to enter the fullscreen display mode. Drag downward on the screen to view the workout information displays.

Touch the various workout information displays to view more options. Touch the more button (+ symbol) to view statistics or charts. Touch the center of the screen to view even more display mode options.

If desired, adjust the volume level by pressing the volume increase and decrease buttons.

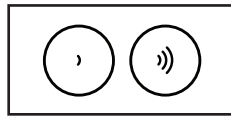

To pause the workout, simply touch the screen or stop pedaling. To continue the workout, simply resume pedaling.

To end the workout session, touch the screen to pause the workout, and then follow the prompts on the screen to end the workout and return to the main menu.

#### 5. Measure your heart rate if desired.

You can measure your heart rate using either the handgrip heart rate monitor or an optional chest heart rate monitor (**see page 25 for information about the optional chest heart rate monitor**). Note: The console is compatible with Bluetooth® Smart heart rate monitors.

**Note: If you use both heart rate monitors at the same time, the Bluetooth Smart heart rate monitor will have priority.**

If there are sheets of plastic on the metal contacts (A) on the handgrip heart rate

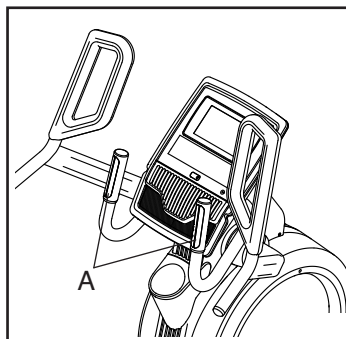

**monitor, remove the plastic.** To measure your heart rate, hold the handgrip heart rate monitor with your palms resting against the contacts. **Avoid moving your hands or gripping the contacts tightly.**

**When your pulse is detected, your heart rate will be shown. For the most accurate heart rate reading, hold the contacts for at least 15 seconds.**

If the display does not show your heart rate, make sure that your hands are positioned as described. Be careful not to move your hands excessively or to squeeze the contacts tightly. For optimal performance, clean the contacts using a soft cloth; **never use alcohol, abrasives, or chemicals to clean the contacts.**

#### 6. Turn on the fan if desired.

The fan has several speed settings, including an auto mode. While the auto mode is selected, the speed of the fan will automatically increase or decrease as your pedaling speed increases or decreases. Press the fan increase and decrease buttons repeatedly to select a fan speed or to turn off the fan.

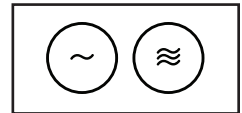

Note: If the pedals are not moved for a while when the main menu is selected, the fan will turn off automatically.

#### 7. When you are finished exercising, the console will turn off automatically.

See HOW TO TURN OFF THE CONSOLE on page 16.

## HOW TO USE A FEATURED WORKOUT OR AN ONBOARD WORKOUT

### 1. Touch the screen or press any button on the console to turn on the console.

See HOW TO TURN ON THE CONSOLE on page 16. Note: It may take a few moments for the console to be ready for use.

### 2. Select the main menu or the workout library.

When you turn on the console, the main menu will appear on the screen after the console boots up.

If you are in a workout, touch the screen and follow the prompts to end the workout and return to the main menu. If you are in the settings menus, touch the back button (arrow symbol) and then touch the close button (x symbol) to return to the main menu.

Touch the buttons at the bottom of the screen to select either the main menu (Home button) or the workout library (Browse button).

### 3. Select a workout.

To select a workout from the main menu or the workout library, simply touch the desired workout button on the screen. Slide or flick the screen to scroll upward or downward if necessary.

Note: To use a featured workout, the console must be connected to a wireless network (see HOW TO CONNECT TO A WIRELESS NETWORK on page 24).

The featured workouts on your console will change periodically. To save one of the featured workouts for future use, you can add it as a favorite by touching the favorites button (heart symbol). You must be logged into your iFit account to save a featured map workout (see step 3 on page 22).

To draw your own map for a workout, see HOW TO CREATE A DRAW-YOUR-OWN-MAP WORKOUT on page 21.

When you select a workout, the screen will show an overview of the workout that includes details such as the duration and distance of the workout and the approximate number of calories you will burn during the workout.

### 4. Start the workout.

Touch *Start Workout* to start the workout.

The workout will function in the same way as the manual mode (see page 17).

During some workouts, an iFit coach will guide you through a video workout. Touch the sound button (music notes symbol) to select music, trainer voice, and volume options for the workout.

During some workouts, the screen will show a map of the route and a marker indicating your progress. Touch the buttons on the screen to select the desired map options.

During some workouts, the screen may show a target speed. As you exercise, keep your pedaling speed near the target speed shown on the screen. A message may appear prompting you to increase, decrease, or maintain your pedaling speed.

**IMPORTANT: The target speed is intended only to provide motivation. Your actual pedaling speed may be slower than the target speed. Make sure to pedal at a speed that is comfortable for you.**

If the resistance level is too high or too low, you can manually override the setting by pressing the Resistance buttons. **If you press a Resistance button**, you can then manually control the resistance level (see step 3 on page 17). **To return to the programmed resistance settings of the workout**, touch *Follow Workout*.

**Note: The calorie goal shown in the workout description is an estimate of the number of calories that you will burn during the workout. The actual number of calories that you burn will depend on various factors, such as your weight. In addition, if you manually change the resistance level during the workout, the number of calories you burn will be affected.**

To pause the workout, simply touch the screen or stop pedaling. To continue the workout, simply resume pedaling.

To end the workout, touch the screen to pause the workout, and then follow the prompts on the screen to end the workout and return to the main menu.

When the workout ends, a workout summary will appear on the screen. If desired, you can select options such as adding the workout to your schedule (see HOW TO USE AN IFIT WORKOUT on page 22) or adding the workout to your favorites list. Then, touch *Save Workout* to return to the main menu.

**5. Follow your progress.**

See step 4 on page 18.

**6. Measure your heart rate if desired.**

See step 5 on page 18.

**7. Turn on the fan if desired.**

See step 6 on page 18.

**8. When you are finished exercising, the console will turn off automatically.**

See HOW TO TURN OFF THE CONSOLE on page 16.

## HOW TO CREATE A DRAW-YOUR-OWN-MAP WORKOUT

### 1. Touch the screen or press any button on the console to turn on the console.

See HOW TO TURN ON THE CONSOLE on page 16. Note: It may take a few moments for the console to be ready for use.

### 2. Select a draw-your-own-map workout.

When you turn on the console, the main menu will appear on the screen after the console boots up.

If you are in a workout, touch the screen and follow the prompts to end the workout and return to the main menu. If you are in the settings menus, touch the back button (arrow symbol) and then touch the close button (x symbol) to return to the main menu.

To select a draw-your-own-map workout, touch the Create button at the bottom of the screen.

### 3. Draw your map.

Navigate to the area on the map where you want to draw your workout by typing in the search box or by sliding your fingers on the screen. Touch the screen to add the start point for your workout. Then, touch the screen to add the end point for your workout.

If you want to start and end your workout at the same point, touch *Close Loop* or *Out & Back* in the map options. You can also select whether you want your workout to snap to the road.

If you make a mistake, touch *Undo* in the map options.

The screen will display the elevation and distance statistics for your workout.

### 4. Save your workout.

Touch *Save New Workout* to save your workout. If desired, enter a title and description for your workout. Then, touch the continue button (> symbol).

### 5. Start the workout.

Touch *Start Workout* to start the workout. The workout will function in the same way as a featured workout or an onboard workout (see page 19).

### 6. Follow your progress.

See step 4 on page 18.

### 7. Measure your heart rate if desired.

See step 5 on page 18.

### 8. Turn on the fan if desired.

See step 6 on page 18.

### 9. When you are finished exercising, the console will turn off automatically.

See HOW TO TURN OFF THE CONSOLE on page 16.

## HOW TO USE AN iFIT WORKOUT

To use an iFit workout, the console must be connected to a wireless network (see HOW TO CONNECT TO A WIRELESS NETWORK on page 24). An iFit account is also required.

### 1. Add workouts to your schedule on iFit.com.

On your computer, smartphone, tablet, or other device, open an internet browser, go to iFit.com, and log in to your iFit account.

Next, navigate to Menu > Library on the website. Browse the workout programs in the library and join the desired workouts.

Then, navigate to Menu > Schedule to view your schedule. All of the workouts that you have joined will appear on your schedule; you can arrange or delete the workouts on your schedule as desired.

Take time to explore the iFit.com website before you log out.

### 2. Select the main menu.

When you turn on the console, the main menu will appear on the screen after the console boots up.

If you are in a workout, touch the screen and follow the prompts to end the workout and return to the main menu. If you are in the settings menus, touch the back button (arrow symbol) and then touch the close button (x symbol) to return to the main menu.

### 3. Log in to your iFit account.

If you have not already done so, touch the menu button (three horizontal lines symbol) on the screen and then touch *Log in* to log in to your iFit account. Follow the prompts on the screen to enter your username and password.

To switch users within your iFit account, touch the menu button, touch *Settings*, and then touch *Manage Accounts*. If more than one user is associated with the account, a list of users will appear. Touch the name of the desired user.

### 4. Select an iFit workout that you have previously added to your schedule on iFit.com.

**IMPORTANT: Before iFit workouts will load, you must add them to your schedule on iFit.com (see step 1).**

To load an iFit workout from iFit.com to the console, touch the Calendar button at the bottom of the screen.

When you load a workout, the screen will show an overview of the workout that includes details such as the duration and distance of the workout and the approximate number of calories you will burn during the workout.

### 5. Start the workout.

Touch *Start Workout* to start the workout. The workout will function in the same way as a featured workout or an onboard workout (see page 19).

### 6. Follow your progress.

See step 4 on page 18.

### 7. Measure your heart rate if desired.

See step 5 on page 18.

### 8. Turn on the fan if desired.

See step 6 on page 18.

### 9. When you are finished exercising, the console will turn off automatically.

See HOW TO TURN OFF THE CONSOLE on page 16.

**For more information about iFit, go to iFit.com.**

## HOW TO CHANGE CONSOLE SETTINGS

**IMPORTANT: Some of the settings and features described may not be enabled.** Occasionally, a firmware update may cause your console to function slightly differently.

### 1. Select the settings main menu.

First, turn on the power (see HOW TO TURN ON THE CONSOLE on page 16). Note: It may take a few moments for the console to be ready for use.

Next, select the main menu (Home button). When you turn on the console, the main menu will appear on the screen after the console boots up. If you are in a workout, touch the screen and follow the prompts to end the workout and return to the main menu. If you are in the settings menus, touch the back button (arrow symbol) and then touch the close button (x symbol) to return to the main menu.

Then, touch the menu button (three horizontal lines symbol) on the screen, and then touch *Settings*. The settings menu will appear on the screen.

### 2. Navigate the settings menus and change settings as desired.

Slide or flick the screen to scroll upward or downward if necessary. To view a settings menu, simply touch the menu name. To exit a menu, touch the back button (arrow symbol). You may be able to view and change settings in the following settings menus:

#### Account

- My Profile
- In Workout
- Manage Accounts

#### Equipment

- Equipment Info
- Equipment Settings
- Maintenance
- Wi-Fi

#### About

- Legal

### 3. Customize the unit of measurement and other settings.

To customize the unit of measurement, the time zone, or other settings, touch *Equipment Info* or *Equipment Settings*, and then touch the desired settings.

The console can display speed and distance in either standard or metric units of measurement.

### 4. View machine information or console app information.

Touch *Equipment Info*, and then touch *Machine Info* or *App Info* to view information about your trainer or about the console app.

### 5. Update the console firmware.

**For the best results, regularly check for firmware updates.** Touch *Maintenance*, and then touch *Update* to check for firmware updates using your wireless network. The update will begin automatically. **IMPORTANT: To avoid damaging the trainer, do not unplug the power adapter while the firmware is being updated.**

The screen will show the progress of the update. When the update is complete, the trainer will turn off and then turn back on. If it does not, unplug the power adapter. Wait for several seconds, and then plug in the power adapter. Note: It may take a few minutes for the console to be ready for use.

Note: Occasionally, a firmware update may cause the console to function slightly differently. These updates are always designed to improve your exercise experience.

### 6. Exit the settings main menu.

If you are in a settings menu, touch the back button. Then, touch the close button (x symbol) to exit the settings main menu.

## HOW TO CONNECT TO A WIRELESS NETWORK

To use iFit workouts and to use several other features of the console, the console must be connected to a wireless network.

### 1. Select the main menu.

First, turn on the power (see HOW TO TURN ON THE CONSOLE on page 16). Note: It may take a few moments for the console to be ready for use.

Next, select the main menu (Home button). When you turn on the console, the main menu will appear on the screen after the console boots up. If you are in a workout, touch the screen and follow the prompts to end the workout and return to the main menu. If you are in the settings menus, touch the back button (arrow symbol) and then touch the close button (x symbol) to return to the main menu.

### 2. Select the wireless network menu.

Touch the menu button (three horizontal lines symbol), and then touch *Wi-Fi* to select the wireless network menu.

### 3. Enable Wi-Fi.

Make sure that Wi-Fi® is enabled. If it is not enabled, touch the *Wi-Fi* toggle to enable it.

### 4. Set up and manage a wireless network connection.

When Wi-Fi is enabled, the screen will show a list of available networks. Note: It may take a few moments for the list of wireless networks to appear.

Note: You must have your own wireless network and an 802.11b/g/n router with SSID broadcast enabled (hidden networks are not supported).

When a list of networks appears, touch the desired network. Note: You will need to know your network name (SSID). If your network has a password, you will also need to know the password.

Follow the prompts on the screen to enter your password and connect to the selected wireless network. (To use the keyboard, see HOW TO USE THE TOUCH SCREEN on page 16.)

When the console is connected to your wireless network, a checkmark will appear next to the wireless network name.

If you are having problems connecting to an encrypted network, make sure that your password is correct. Note: Passwords are case-sensitive.

Note: The console supports unsecured and secured (WEP, WPA™, and WPA2™) encryption. A broadband connection is recommended; performance depends on connection speed.

**Note: If you have questions after following these instructions, go to [support.iFit.com](http://support.iFit.com) for assistance.**

### 5. Exit the wireless network menu.

To exit the wireless network menu, touch the back button (arrow symbol).



## HOW TO USE THE SOUND SYSTEM

To play music or audio books through the console sound system while you exercise, plug a 3.5 mm male to 3.5 mm male audio cable (not included) into the jack on the console and into a jack on your personal audio player; **make sure that the audio cable is fully plugged in. Note: To purchase an audio cable, see your local electronics store.**

Next, press the play button on your personal audio player. Adjust the volume level using the volume increase and decrease buttons or the volume control on your personal audio player.

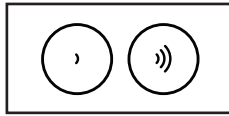

## HOW TO CONNECT TO THE SOUND SYSTEM WITH BLUETOOTH

If desired, you can connect your smart device to the console sound system with Bluetooth.

First, make sure that the Bluetooth option is enabled on your device.

Next, place or hold your device near the console. Then, pair your device to the console as follows: Press and hold the Bluetooth Audio button on the console for 3 seconds; the console will enter pairing mode.

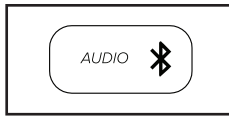

When your device and the console pair successfully, the audio from your device will play through the console sound system.

The console can save 8 devices in its memory. If you have previously paired your device to the console, simply press the Bluetooth Audio button to connect your device to the console.

You can erase devices from the console memory if necessary. To erase all the Bluetooth-enabled devices saved in the console memory, press and hold the Bluetooth Audio button for 10 seconds.

## THE OPTIONAL CHEST HEART RATE MONITOR

Whether your goal is to burn fat or to strengthen your cardiovascular system, the key to achieving the best results is to maintain the proper heart rate during your workouts.

The optional chest heart rate monitor will enable you to continuously monitor your heart rate while you exercise, helping you to reach your personal fitness goals. **To purchase a chest heart rate monitor, please see the front cover of this manual.**

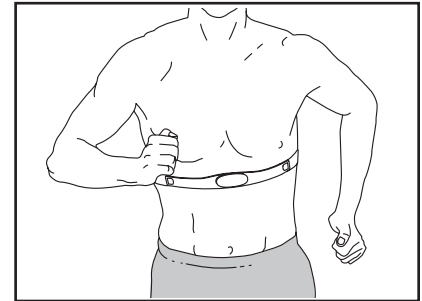

Note: The console is compatible with all Bluetooth Smart heart rate monitors.

---

## FCC INFORMATION

This equipment has been tested and found to comply with the limits for a Class B digital device, pursuant to part 15 of the FCC Rules. These limits are designed to provide reasonable protection against harmful interference in a residential installation. This equipment generates, uses, and can radiate radio frequency energy and, if not installed and used in accordance with the instructions, may cause harmful interference to radio communications. However, there is no guarantee that interference will not occur in a particular installation. If this equipment does cause harmful interference to radio or television reception, which can be determined by turning the equipment off and on, try to correct the interference by one or more of the following measures:

- Reorient or relocate the receiving antenna.
- Increase the separation between the equipment and the receiver.
- Connect the equipment into an outlet on a circuit different from that to which the receiver is connected.
- Consult the dealer or an experienced radio/TV technician for help.

**FCC CAUTION: To assure continued compliance, use only shielded interface cables when connecting to computer or peripheral devices. Changes or modifications not expressly approved by the party responsible for compliance could void the user's authority to operate this equipment.**

**IMPORTANT: To satisfy exposure compliance requirements, the antenna and transmitter in the console must be at least 8 in. (20 cm) from all persons and must not be near or connected to any other antenna or transmitter.**

**Note: The console contains FCC ID: OMC402546.**

# MAINTENANCE AND TROUBLESHOOTING

## MAINTENANCE

Regular maintenance is important for optimal performance and to reduce wear. Inspect and properly tighten all parts each time the trainer is used. Replace any worn parts immediately.

To clean the trainer, use a damp cloth and a small amount of mild soap. **IMPORTANT: To avoid damage to the console, keep liquids away from the console and keep the console out of direct sunlight.**

## CONSOLE TROUBLESHOOTING

If the console does not turn on, make sure that the power adapter is fully plugged in.

If the console does not display your heart rate when you hold the handgrip heart rate monitor, or if the displayed heart rate appears to be too high or too low, see step 5 on page 18.

**If a replacement power adapter is needed, call the telephone number on the cover of this manual. IMPORTANT: To avoid damaging the console, use only a manufacturer-supplied regulated power adapter.**

If the console does not boot up properly, or if the console freezes and does not respond, reset the console to the factory default settings. **IMPORTANT: Doing this will erase all custom settings you have made to the console.** Resetting the console requires two people. First, unplug the power adapter. Next, locate the small reset opening (A) on the back or the side of the console. Using a bent paper clip, press and hold the reset button inside the opening, and have a second person plug in the power adapter. Continue holding the reset button until the console turns on. When the reset operation is complete, the console will turn off and then turn back on. If it does not, unplug and then plug in the power adapter. Once the console turns on, check for firmware updates (see step 5 on page 23). Note: It may take a few minutes for the console to be ready for use.

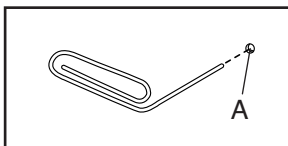

## PEDAL TROUBLESHOOTING

If the pedals bottom out while you are exercising and become difficult to move, rock your weight backward and forward on the pedals until the pedals become free and the flywheel inside the trainer begins turning again.

## HOW TO ADJUST THE REED SWITCH

If the console does not display correct feedback, the reed switch should be adjusted. To adjust the reed switch, first **unplug the power adapter.**

Next, remove the four indicated M4 x 16mm Flat Head Screws (101) and the Lower Rear Shield Cover (68).

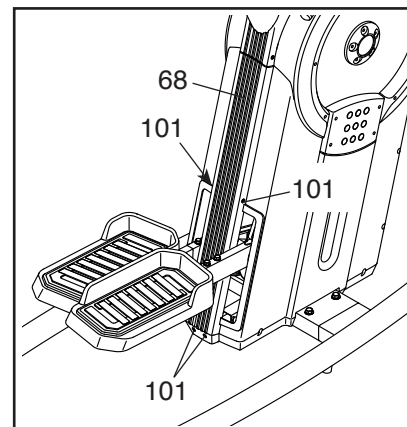

Next, turn the Large Pulley (21) until a Pulley Magnet (104) is aligned with the Reed Switch (116). Then, slightly loosen the M4 x 19mm Screw (113), slide the Reed Switch slightly closer to or away from the Pulley Magnet, and retighten the Screw.

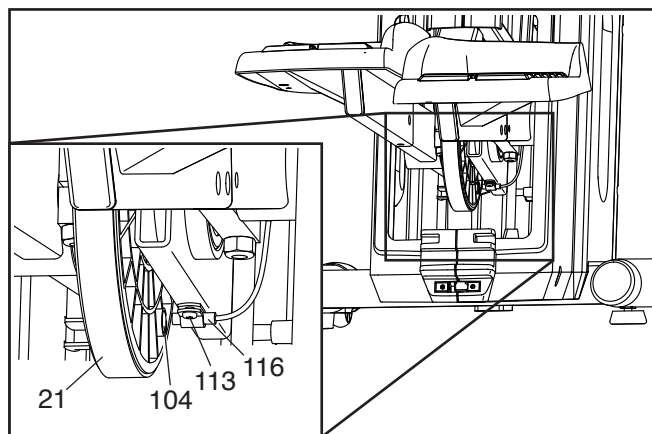

Then, plug in the power adapter and turn the Large Pulley (21) for a moment. Repeat these actions, if necessary, until the console displays correct feedback. Then, reattach the lower rear shield cover.

## HOW TO ADJUST THE DRIVE BELT

If the pedals slip while you are pedaling, even while the resistance is adjusted to the highest level, the drive belts may need to be adjusted. To adjust the drive belts, first **unplug the power adapter**.

Next, remove the four indicated M4 x 16mm Flat Head Screws (101) and the Lower Rear Shield Cover (68).

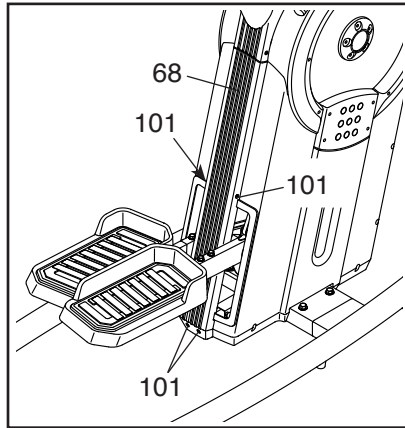

Then, locate the lower Adjustment Screw (A). Tighten the lower Adjustment Screw four turns; this will tighten the Large Drive Belt (31).

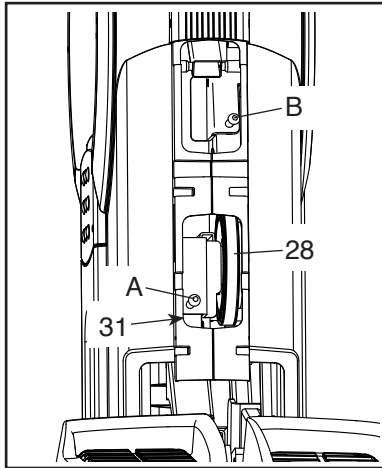

Stand on the trainer and pedal for a few moments. If the pedals still slip, step off the trainer and locate the upper Adjustment Screw (B). Tighten the upper Adjustment Screw two turns; this will tighten the Small Drive Belt (28).

Stand on the trainer again and pedal for a few moments. If the pedals still slip, step off the trainer and tighten the lower Adjustment Screw (A) four turns; this will again tighten the Large Drive Belt (31).

When you have properly adjusted the drive belts, reattach the lower rear shield cover.

# EXERCISE GUIDELINES

**⚠️ WARNING:** Before beginning this or any exercise program, consult your physician. This is especially important for persons over age 35 or persons with pre-existing health problems.

The heart rate monitor is not a medical device. Various factors may affect the accuracy of heart rate readings. The heart rate monitor is intended only as an exercise aid in determining heart rate trends in general.

These guidelines will help you to plan your exercise program. For detailed exercise information, obtain a reputable book or consult your physician. Remember, proper nutrition and adequate rest are essential for successful results.

## EXERCISE INTENSITY

Whether your goal is to burn fat or to strengthen your cardiovascular system, exercising at the proper intensity is the key to achieving results. You can use your heart rate as a guide to find the proper intensity level. The chart below shows recommended heart rates for fat burning and aerobic exercise.

165	155	145	140	130	125	115	♥
145	138	130	125	118	110	103	♥
125	120	115	110	105	95	90	♥
<hr/>							
20	30	40	50	60	70	80	

To find the proper intensity level, find your age at the bottom of the chart (ages are rounded off to the nearest ten years). The three numbers listed above your age define your “training zone.” The lowest number is the heart rate for fat burning, the middle number is the heart rate for maximum fat burning, and the highest number is the heart rate for aerobic exercise.

**Burning Fat**—To burn fat effectively, you must exercise at a low intensity level for a sustained period of time. During the first few minutes of exercise, your body uses carbohydrate calories for energy. Only after the first few minutes of exercise does your body begin to use stored fat calories for energy. If your goal is to burn fat, adjust the intensity of your exercise until your heart rate is near the lowest number in your training zone. For maximum fat burning, exercise with your heart rate near the middle number in your training zone.

**Aerobic Exercise**—If your goal is to strengthen your cardiovascular system, you must perform aerobic exercise, which is activity that requires large amounts of oxygen for prolonged periods of time. For aerobic exercise, adjust the intensity of your exercise until your heart rate is near the highest number in your training zone.

## WORKOUT GUIDELINES

**Warming Up**—Start with 5 to 10 minutes of stretching and light exercise. A warm-up increases your body temperature, heart rate, and circulation in preparation for exercise.

**Training Zone Exercise**—Exercise for 20 to 30 minutes with your heart rate in your training zone. (During the first few weeks of your exercise program, do not keep your heart rate in your training zone for longer than 20 minutes.) Breathe regularly and deeply as you exercise; never hold your breath.

**Cooling Down**—Finish with 5 to 10 minutes of stretching. Stretching increases the flexibility of your muscles and helps to prevent post-exercise problems.

## EXERCISE FREQUENCY

To maintain or improve your condition, complete three workouts each week, with at least one day of rest between workouts. After a few months of regular exercise, you may complete up to five workouts each week, if desired. Remember, the key to success is to make exercise a regular and enjoyable part of your everyday life.

## SUGGESTED STRETCHES

The correct form for several basic stretches is shown at the right. Move slowly as you stretch; never bounce.

### 1. Toe Touch Stretch

Stand with your knees bent slightly and slowly bend forward from your hips. Allow your back and shoulders to relax as you reach down toward your toes as far as possible. Hold for 15 counts, then relax. Repeat 3 times. Stretches: Hamstrings, back of knees and back.

### 2. Hamstring Stretch

Sit with one leg extended. Bring the sole of the opposite foot toward you and rest it against the inner thigh of your extended leg. Reach toward your toes as far as possible. Hold for 15 counts, then relax. Repeat 3 times for each leg. Stretches: Hamstrings, lower back and groin.

### 3. Calf/Achilles Stretch

With one leg in front of the other, reach forward and place your hands against a wall. Keep your back leg straight and your back foot flat on the floor. Bend your front leg, lean forward and move your hips toward the wall. Hold for 15 counts, then relax. Repeat 3 times for each leg. To cause further stretching of the achilles tendons, bend your back leg as well. Stretches: Calves, achilles tendons and ankles.

### 4. Quadriceps Stretch

With one hand against a wall for balance, reach back and grasp one foot with your other hand. Bring your heel as close to your buttocks as possible. Hold for 15 counts, then relax. Repeat 3 times for each leg. Stretches: Quadriceps and hip muscles.

### 5. Inner Thigh Stretch

Sit with the soles of your feet together and your knees outward. Pull your feet toward your groin area as far as possible. Hold for 15 counts, then relax. Repeat 3 times. Stretches: Quadriceps and hip muscles.

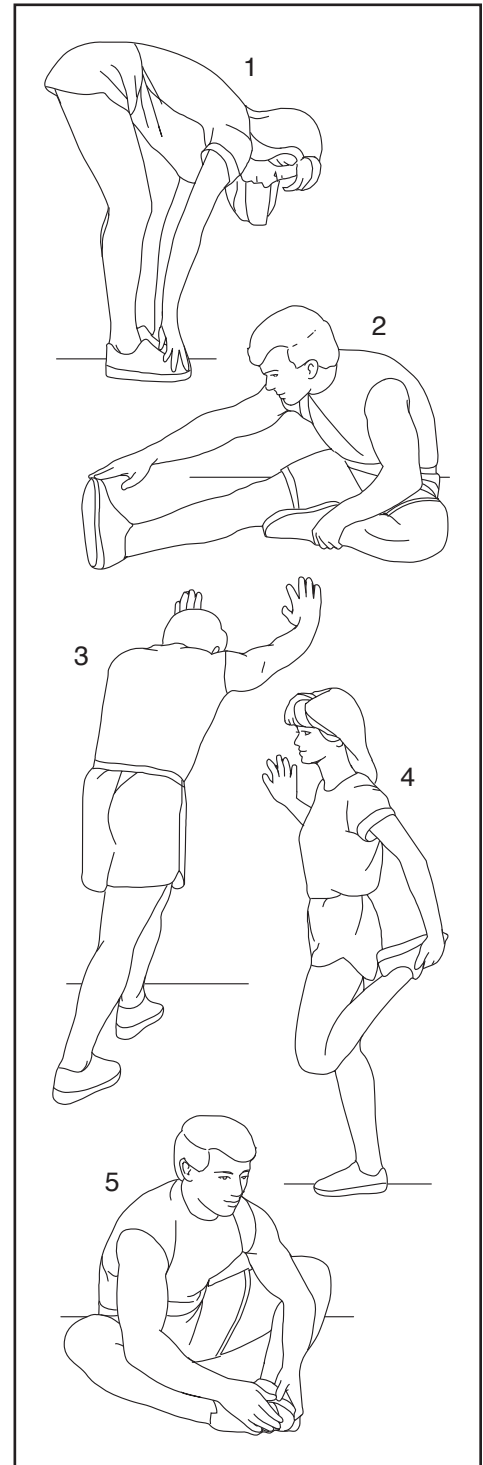

---

# NOTES

# PART LIST

Model No. PFEL09920.0 R1219A

Key No.	Qty.	Description	Key No.	Qty.	Description
1	1	Frame	51	1	Right Shield
2	1	Right Pedal Base	52	1	Front Cover
3	1	Left Pedal Base	53	1	Rear Cover
4	1	Console Bracket	54	1	Accessory Tray Base
5	1	Console	55	2	Stabilizer Cap
6	2	Snap Ring	56	4	Foot
7	1	Console Cover	57	2	Wheel
8	1	Right Stabilizer	58	1	Right Wheel Cover
9	1	Left Stabilizer	59	2	Handlebar Cap
10	1	Right Handlebar	60	2	Disc Axle Bearing
11	1	Left Handlebar	61	1	Left Rear Handlebar Cover
12	1	Shield Cover	62	1	Left Front Handlebar Cover
13	2	Pulse Grip	63	1	Right Rear Handlebar Cover
14	1	Left Handlebar Arm	64	1	Right Front Handlebar Cover
15	1	Right Handlebar Arm	65	2	Rear Pivot Cover
16	1	Magnet Bracket	66	2	Front Pivot Cover
17	2	Idler	67	1	Spring
18	1	Accessory Tray	68	1	Lower Rear Shield Cover
19	1	Exchange Axle	69	2	Leveling Foot
20	1	Medium Pulley	70	10	Small Bearing
21	1	Large Pulley	71	4	Medium Bearing
22	1	Right Pedal	72	2	Large Bearing
23	1	Left Pedal	73	8	Bushing
24	1	Right Pedal Leg	74	2	Large Spacer
25	1	Left Pedal Leg	75	2	Small Spacer
26	2	Connector Arm	76	2	M10 Jam Nut
27	1	Disc Axle	77	2	Crank Washer
28	1	Small Drive Belt	78	6	M8 Washer
29	2	Crank Arm	79	4	M6 Washer
30	1	Crank	80	2	M5 Nut
31	1	Large Drive Belt	81	2	M10 Shoulder Bolt
32	2	Disc	82	5	M4 x 42mm Screw
33	2	Disc Hub	83	8	Clip
34	1	Sprocket	84	4	M6 x 14mm Screw
35	2	Link Arm	85	4	M5 x 16mm Screw
36	1	Resistance Motor	86	1	M3.5 x 12mm Screw
37	1	Resistance Disc	87	8	M8 x 16mm Screw
38	1	Resistance Arm	88	10	Disc Screw
39	1	Resistance Block	89	2	M10 Locknut
40	1	Power Receptacle/Wire	90	2	M10 x 55mm Hex Bolt
41	1	Small Pulley	91	2	Axle Screw
42	1	Clamp	92	2	Flange
43	3	Key	93	2	Stud
44	2	Magnet Cover	94	2	M10 x 55mm Bolt
45	2	M8 Small Washer	95	2	Adjustment Screw
46	1	Left Wheel Cover	96	2	M8 x 15mm Screw
47	2	Self-aligning Bearing	97	2	M8 Shoulder Screw
48	2	Disc Axle Bushing	98	1	M8 x 30mm Bolt
49	2	Disc Ring	99	3	M8 Locknut
50	1	Left Shield	100	6	M8 x 23mm Screw



Key No.	Qty.	Description	Key No.	Qty.	Description
101	14	M4 x 16mm Flat Head Screw	112	1	M10 Screw
102	8	M8 x 20mm Screw	113	25	M4 x 19mm Screw
103	18	Cap Screw	114	3	M4 x 12mm Screw
104	2	Pulley Magnet	115	1	Main Wire
105	6	M8 x 25mm Screw	116	1	Reed Switch/Wire
106	10	M4 x 16mm Screw	117	1	Pulse Wire
107	20	M4 x 22mm Screw	118	1	Power Adapter
108	8	M6 x 12mm Screw	119	2	Crank Cover Disc
109	2	M8 x 86mm Screw	*	–	User's Manual
110	8	M10 x 20mm Screw	*	–	Assembly Tool
111	2	Slant Cap	*	–	Grease Packet

Note: Specifications are subject to change without notice. For information about ordering replacement parts, see the back cover of this manual. \*These parts are not illustrated.

# EXPLODED DRAWING A

Model No. PFEL09920.0 R1219A

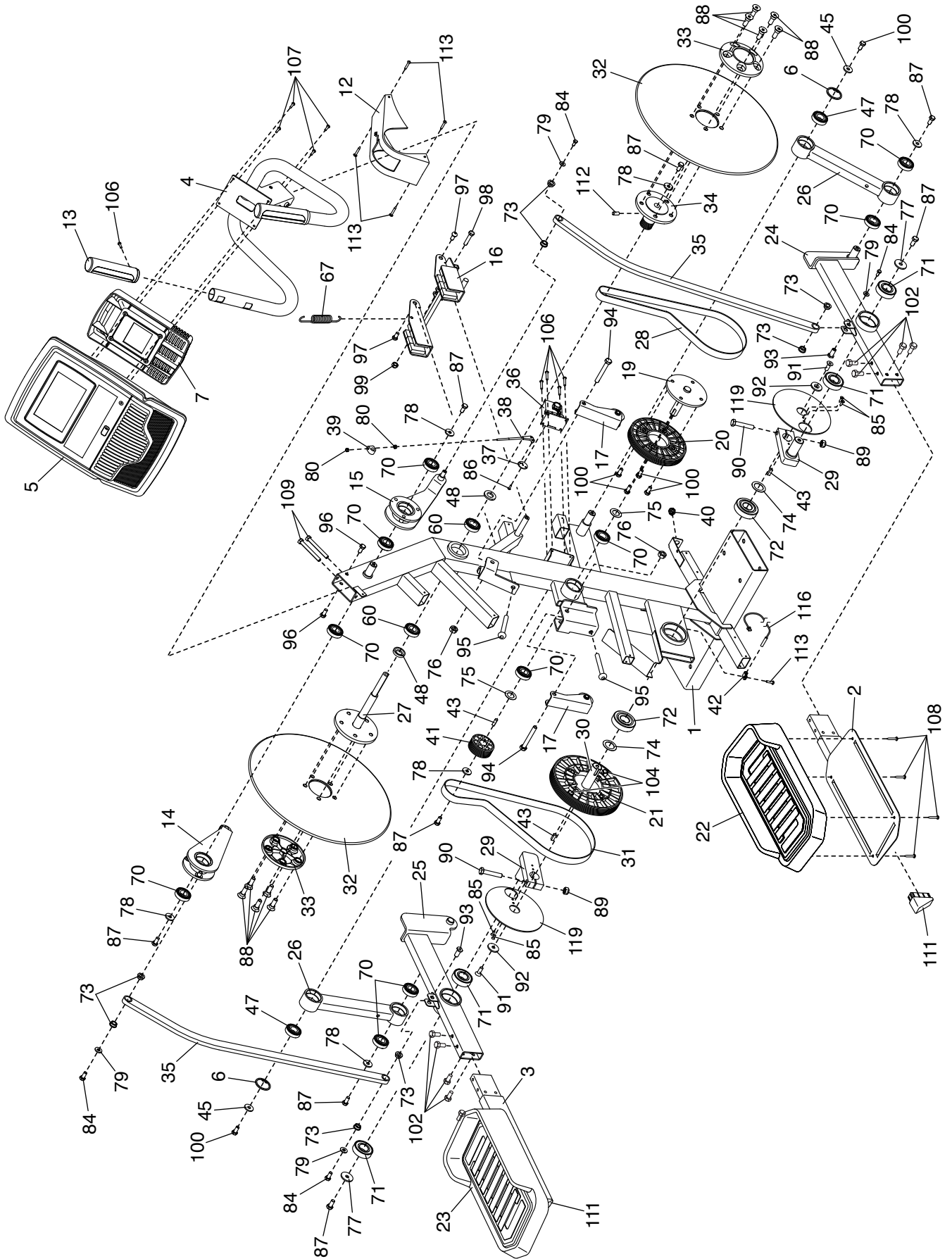

# EXPLODED DRAWING B

Model No. PFEL09920.0 R1219A

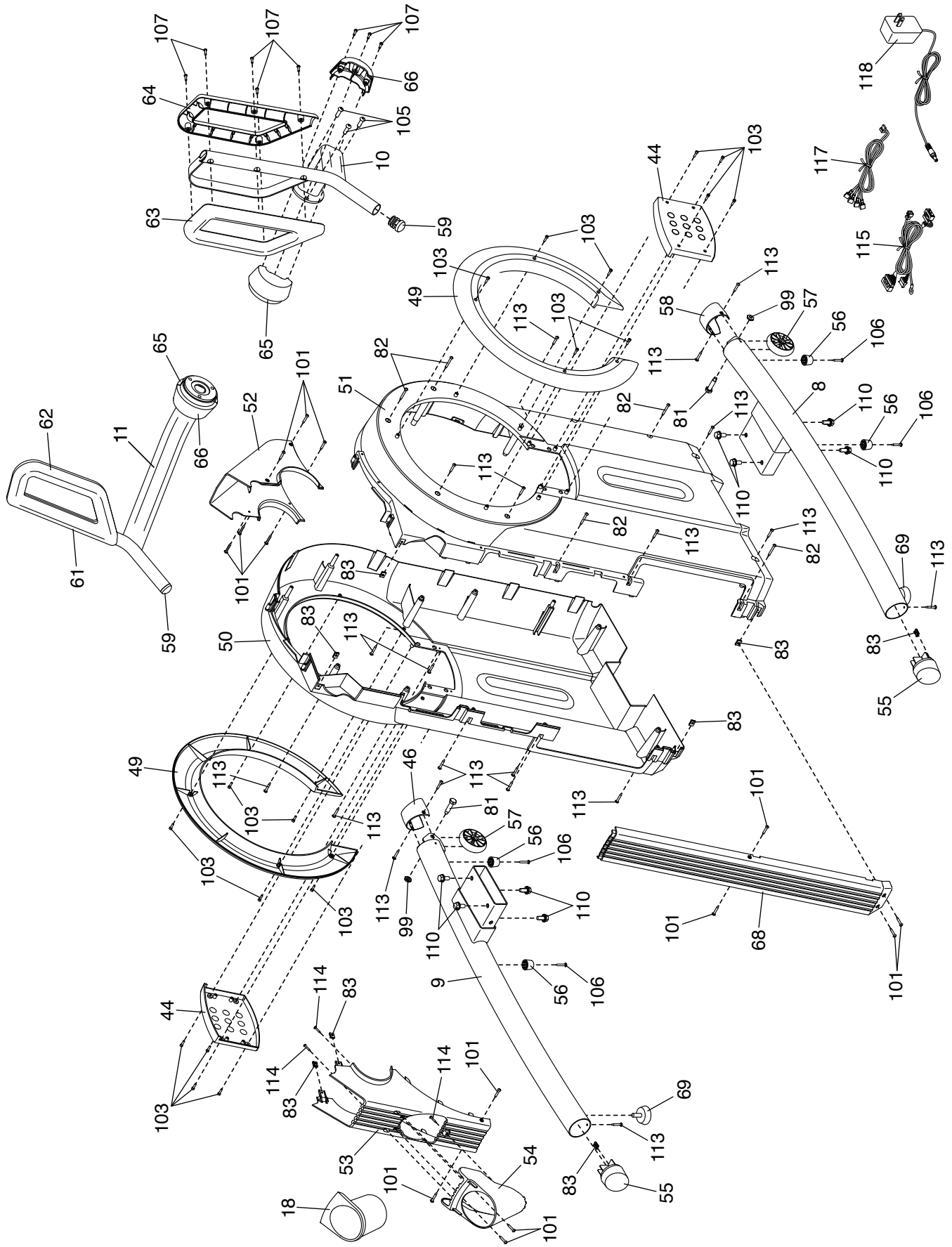

---

# ORDERING REPLACEMENT PARTS

To order replacement parts, please see the front cover of this manual. To help us assist you, be prepared to provide the following information when contacting us:

- the model number and serial number of the product (see the front cover of this manual)
- the name of the product (see the front cover of this manual)
- the key number and description of the replacement part(s) (see the PART LIST and the EXPLODED DRAWING near the end of this manual)

## LIMITED WARRANTY

**IMPORTANT: To protect your fitness equipment with an extended service plan, see page 4.**

ICON Health & Fitness, Inc. (ICON) warrants this product to be free from defects in workmanship and material, under normal use and service conditions. The frame is warranted for ten (10) years from the date of purchase. Parts are warranted for two (2) years from the date of purchase. Labor is warranted for one (1) year from the date of purchase.

This warranty extends only to the original purchaser (customer) and is not transferrable. ICON's obligation under this warranty is limited to repairing or replacing, at ICON's option, the product through one of its authorized service providers. All repairs for which warranty claims are made must be preauthorized by ICON. If replacement parts are shipped while the product is under warranty, the customer will be responsible for a minimal handling charge. For in-home service, the customer may be responsible for a minimal trip charge. This warranty does not extend to freight damage to the product. This warranty will automatically be voided by the following conditions: (1) if the product is used as a store display model, (2) if the product is purchased or transported outside the USA, (3) if all instructions and warnings in this manual are not followed, (4) if the product is abused or improperly or abnormally used, or (5) if the product is used for commercial or rental purposes. No other warranty beyond that specifically set forth above is authorized by ICON.

ICON is not responsible or liable for the following damages: (1) indirect, special, or consequential damages arising out of or in connection with the use or performance of the product; (2) damages with respect to any economic loss, loss of property, loss of revenues or profits, loss of enjoyment or use, or costs of removal or installation; or (3) other consequential damages of any kind. Some states do not allow the exclusion or limitation of incidental or consequential damages. Accordingly, the above limitation may not apply to the customer.

The warranty extended hereunder is in lieu of any and all other warranties, and any implied warranties of merchantability or fitness for a particular purpose are limited in their scope and duration to the terms set forth herein. Some states do not allow limitations on how long an implied warranty lasts. Accordingly, the above limitation may not apply to the customer. This warranty provides specific legal rights; the customer may have other rights that vary from state to state.

For warranty service, please call the telephone number on the front cover of this manual. Please be prepared to provide the model number and serial number of the product (see the front cover of this manual).

**ICON Health & Fitness, Inc., 1500 S. 1000 W., Logan, UT 84321-9813**