

PRO-FORM[®]

CARBON T7

proform.com

Model No. PFTL87720.0

Serial No. _____

Write the serial number in the space above for reference.

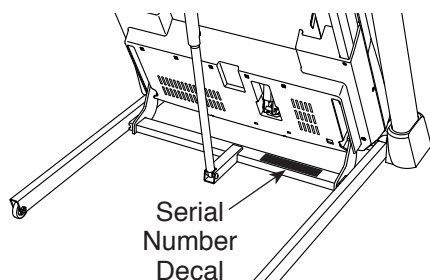

REGISTER YOUR PRODUCT

To register your product and activate your warranty today, go to my.proform.com.

CUSTOMER CARE

For service at any time, go to support.proform.com.

Or call 1-888-533-1333
Mon.–Fri. 6 a.m.–6 p.m. MT
Sat. 8 a.m.–12 p.m. MT

Please do not contact the store.

⚠ CAUTION

Read all precautions and instructions in this manual before using this equipment. Keep this manual for future reference.

USER'S MANUAL



TABLE OF CONTENTS

WARNING DECAL PLACEMENT 2

IMPORTANT PRECAUTIONS 3

BEFORE YOU BEGIN 6

PART IDENTIFICATION CHART 7

ASSEMBLY 8

HOW TO USE THE TREADMILL 16

FCC INFORMATION 27

HOW TO FOLD AND MOVE THE TREADMILL 28

MAINTENANCE AND TROUBLESHOOTING 29

EXERCISE GUIDELINES 32

PART LIST 35

EXPLODED DRAWING 36

ORDERING REPLACEMENT PARTS Back Cover

LIMITED WARRANTY Back Cover

WARNING DECAL PLACEMENT

This drawing shows the locations of the warning decals. **If a decal is missing or illegible, call the telephone number on the front cover of this manual and request a free replacement decal. Apply the decal in the location shown.** Note: The decals may not be shown at actual size.

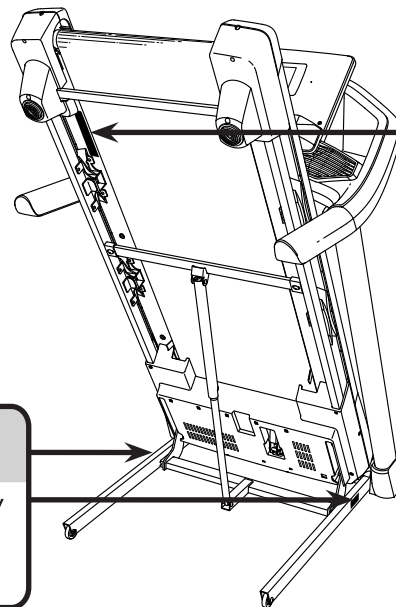

▲ WARNING:

Protect yourself and others from risk of serious injury. Read the user's manual, and:

- Stand only on the side rails when starting or stopping treadmill.
- Change speed in small increments.
- Hold handrails to prevent falling, and always wear the safety clip while operating the treadmill.
- Stop if you feel faint, dizzy, or short of breath.
- Fully engage the storage latch before the treadmill is moved or stored.
- Incline should be set to zero before folding the treadmill into a storage position.
- Never allow children on or around the treadmill.
- Remove the safety key when treadmill is not in use.
- Keep clothing, fingers, and hair away from moving parts.
- Never try to adjust or fix the belt while it is moving.
- Always wear athletic shoes while operating the treadmill.

PROFORM and IFIT are registered trademarks of ICON Health & Fitness, Inc. App store is a trademark of Apple Inc., registered in the U.S. and other countries. Android and Google Play are trademarks of Google LLC. The Bluetooth® word mark and logos are registered trademarks of Bluetooth SIG, Inc. and are used under license. IOS is a trademark or registered trademark of Cisco in the U.S. and other countries and is used under license.

IMPORTANT PRECAUTIONS

⚠️ WARNING: To reduce the risk of burns, fire, electric shock, or injury to persons, read all important precautions and instructions in this manual and all warnings on your treadmill before using your treadmill. ICON assumes no responsibility for personal injury or property damage sustained by or through the use of this product.

1. It is the responsibility of the owner to ensure that all users of this treadmill are adequately informed of all warnings and precautions.
2. Before beginning any exercise program, consult your physician. This is especially important for persons over age 35 or persons with pre-existing health problems.
3. The treadmill is not intended for use by persons with reduced physical, sensory, or mental capabilities or lack of experience and knowledge, unless they have been given supervision or instruction concerning use of the treadmill by someone responsible for their safety.
4. Use the treadmill only as described in this manual.
5. The treadmill is intended for home use only. Do not use the treadmill in any commercial, rental, or institutional setting.
6. Keep the treadmill indoors, away from moisture and dust. Do not put the treadmill in a garage or covered patio, or near water.
7. Place the treadmill on a level surface, with at least 8 ft. (2.4 m) of clearance behind it and 2 ft. (0.6 m) on each side. Do not place the treadmill on any surface that blocks air openings. To protect the floor or carpet from damage, place a mat under the treadmill.
8. Do not operate the treadmill where aerosol products are used or where oxygen is being administered.
9. Keep children under age 16 and pets away from the treadmill at all times.
10. The treadmill should be used only by persons weighing 300 lbs. (136 kg) or less.
11. Never allow more than one person on the treadmill at a time.
12. Wear appropriate exercise clothes while using the treadmill. Do not wear loose clothes that could become caught in the treadmill. Athletic support clothes are recommended for both men and women. Always wear athletic shoes. Never use the treadmill with bare feet, wearing only stockings, or in sandals.
13. Plug the power cord into a surge suppressor (not included), and plug the surge suppressor into an appropriate outlet (see page 16). To avoid overloading the circuit, do not plug other electrical devices, except for low-power devices such as cell phone chargers, into the surge suppressor or into an outlet on the same circuit.
14. Use only a surge suppressor that meets all of the specifications described on page 16. To purchase a surge suppressor, see your local PROFORM dealer, call the telephone number on the front cover of this manual, or see your local electronics store.
15. Failure to use a properly functioning surge suppressor could result in damage to the control system of the treadmill. If the control system is damaged, the walking belt may slow, accelerate, or stop unexpectedly, which may result in a fall and serious injury.
16. Keep the power cord and the surge suppressor away from heated surfaces.
17. Never move the walking belt while the power is turned off. Do not operate the treadmill if the power cord or plug is damaged, or if the treadmill is not working properly. (See MAINTENANCE AND TROUBLESHOOTING on page 29 if the treadmill is not working properly.)
18. Read, understand, and test the emergency stop procedure before using the treadmill (see HOW TO TURN ON THE POWER on page 18). Always wear the clip while using the treadmill.

19. Always stand on the foot rails when starting or stopping the walking belt. Always hold the handrails while using the treadmill.
20. When a person is walking on the treadmill, the noise level of the treadmill will increase.
21. Keep fingers, hair, and clothing away from the moving walking belt. The treadmill is capable of high speeds. Adjust the speed in small increments to avoid sudden jumps in speed.
22. Never leave the treadmill unattended while it is running. Always remove the key, press the power switch into the off position (see the drawing on page 6 for the location of the power switch), and unplug the power cord when the treadmill is not in use.
23. Do not attempt to move the treadmill until it is properly assembled. (See ASSEMBLY on page 8 and HOW TO FOLD AND MOVE THE TREADMILL on page 28.) You must be able to safely lift 45 lbs. (20 kg) to move the treadmill.
24. When folding or moving the treadmill, make sure that the storage latch is holding the frame securely in the storage position. Do not operate the treadmill while it is folded.
25. Do not change the incline of the treadmill by placing objects under the treadmill.
26. Never insert any object into any opening on the treadmill.
27. Inspect and properly tighten all parts each time the treadmill is used.
28. **DANGER:** Always unplug the power cord immediately after use, before cleaning the treadmill, and before performing the maintenance and adjustment procedures described in this manual. Never remove the motor hood unless instructed to do so by an authorized service representative. Servicing other than the procedures in this manual should be performed by an authorized service representative only.
29. Over exercising may result in serious injury or death. If you feel faint, if you become short of breath, or if you experience pain while exercising, stop immediately and cool down.

SAVE THESE INSTRUCTIONS

PROTECT

YOUR FITNESS EQUIPMENT
WITH AN EXTENDED SERVICE PLAN

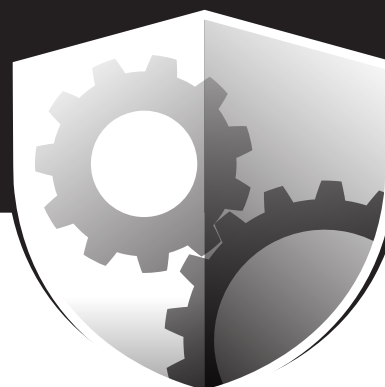

Your new fitness equipment is not an ordinary purchase; it is an investment in your health and well being for years to come.

As the leading provider of manufacturer's extended service plans, ICON strives to protect your equipment and your future.

Please review the following service plans and find one that best fits your needs.

PREVENTIVE MAINTENANCE SERVICE PLANS

Equipment Price	3-Year Plan	5-Year Plan
\$0.00 to \$1000.00	\$199.99	\$289.99
\$1001.00 to \$1500.00	\$259.99	\$379.99
\$1501.00 to \$2500.00	\$339.99	\$489.99
(Bikes/Systems Only) \$0.00 to \$2500.00	\$139.99	NA

Features:

- Includes an annual preventive maintenance and performance check at your convenience
- Unlimited in-home repairs; no shipping required
- Covers parts and labor on all manufacturer's defects, as well as wear and tear on parts
- Up to 5 years of coverage available

STANDARD SERVICE PLANS

Equipment Price	1-Year Plan	2-Year Plan	3-Year Plan
\$0.00 to \$300.00	\$29.99	\$39.99	\$59.99
\$301.00 to \$1000.00	\$89.99	\$119.99	\$149.99
\$1001.00 to \$2000.00	\$109.99	\$139.99	\$179.99
\$2001.00 to \$3000.00	\$179.99	\$209.99	\$239.99

Features:

- Unlimited in-home repairs; no shipping required
- Covers parts and labor on all manufacturer's defects, as well as wear and tear on parts
- Up to 3 years of coverage available

To protect your fitness equipment today, please
call Customer Care at **1-800-677-3838.**
Or, visit us online at **www.utserv.com.**



BEFORE YOU BEGIN

Thank you for selecting the new PROFORM® CARBON T7 treadmill. The CARBON T7 treadmill provides an impressive selection of features designed to make your workouts at home more effective and enjoyable.

For your benefit, read this manual carefully before you use the treadmill. If you have questions after

reading this manual, please see the front cover of this manual. To help us assist you, note the product model number and serial number before contacting us. The model number and the location of the serial number decal are shown on the front cover of this manual.

Before reading further, please familiarize yourself with the parts that are labeled in the drawing below.

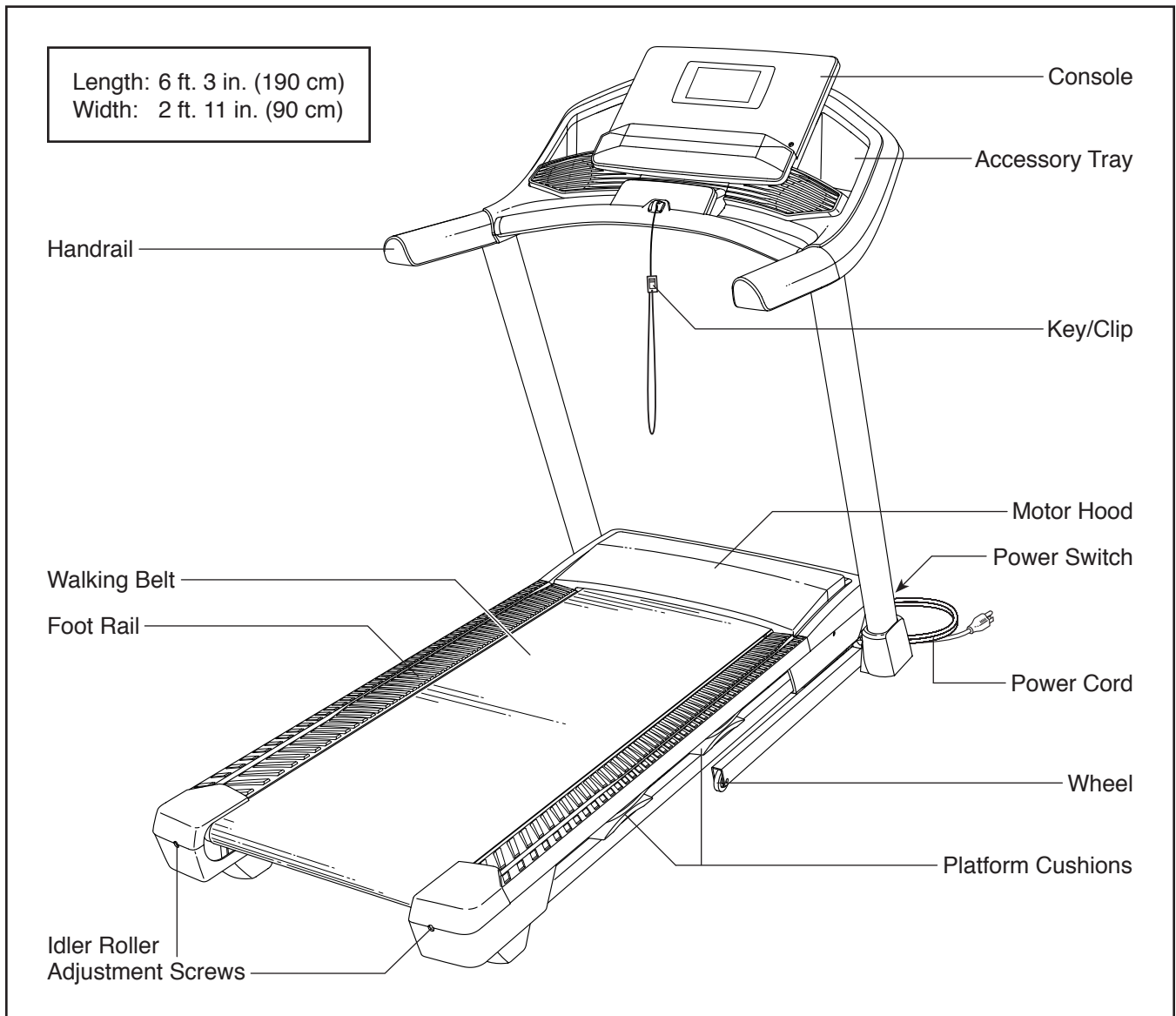

PART IDENTIFICATION CHART

Use the drawings below to identify small parts used for assembly. The number in parentheses below each drawing is the key number of the part, from the PART LIST near the end of this manual. The number following the key number is the quantity used for assembly. **Note: If a part is not in the hardware kit, check to see whether it is preattached. Extra parts may be included.**

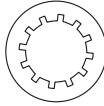
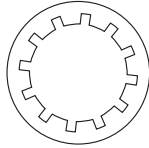
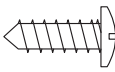
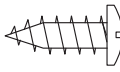
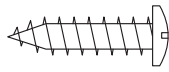
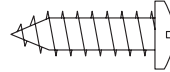
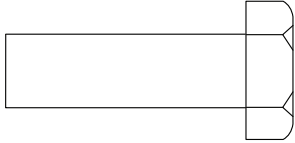
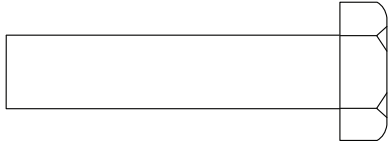
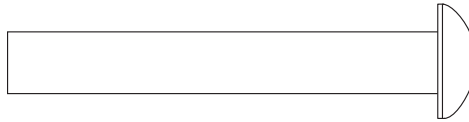
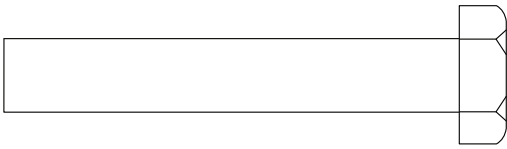
			
1/4" Star Washer (10)-8	5/16" Star Washer (12)-6	3/8" Star Washer (11)-8	
			
#8 x 1/2" Ground Screw (9)-1	#8 x 1/2" Screw (5)-8	#8 x 3/4" Screw (4)-8	#10 x 3/4" Screw (6)-4
			
3/8" x 1 1/4" Screw (1)-2	3/8" x 1 3/4" Screw (2)-2		
			
5/16" x 2 1/4" Screw (7)-4	3/8" x 2 3/8" Screw (3)-4		

ASSEMBLY

Easy step-by-step interactive 3D assembly instructions for this product can be found on

BILT.®

Download the **FREE** App



Scan here and search by your model number



1. To use the assembly steps in this manual, first see the helpful tips below.

- To hire a service technician to assemble this product in your home, call 1-800-445-2480.
- Assembly requires two persons.
- Place all parts in a cleared area and remove the packing materials. Do not dispose of the packing materials until you finish all assembly steps.
- After shipping, there may be an oily substance on the exterior of the treadmill. This is normal. If there is an oily substance on the treadmill, wipe it off with a soft cloth and a mild, non-abrasive cleaner.

- Left parts are marked “L” or “Left” and right parts are marked “R” or “Right.”

- To identify small parts, see page 7.

- Assembly requires the following tools:

the included hex keys



one Phillips screwdriver

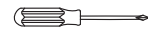

one adjustable wrench



To avoid damaging parts, do not use power tools.

2. **Make sure that the power cord is unplugged.**

Remove the tie securing the Upright Wire (88) to the front of the Base (97).

Next, identify the Right Upright (86). Have a second person hold the Right Upright near the Base (97).

See the inset drawing. Tie the wire tie (A) in the Right Upright (86) securely around the end of the Upright Wire (88). Then, insert the Upright Wire into the lower end of the Right Upright, and pull the upper end of the wire tie until the Wire Harness is routed through the Right Upright.

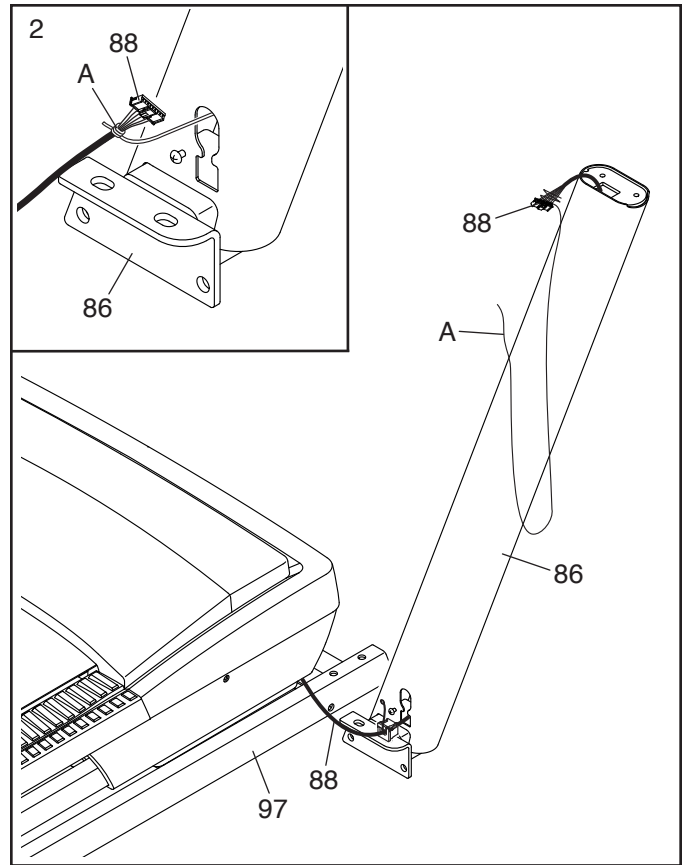

3. Lay the Right Upright (86) near the Base (97). Press the Grommet (89) into the square hole (B) in the Right Upright. **Make sure not to pinch the ground wire (C).**

Next, remove and discard the indicated screw (D).

Then, attach the ground wire to the Right Upright (86) with a #8 x 1/2" Ground Screw (9).

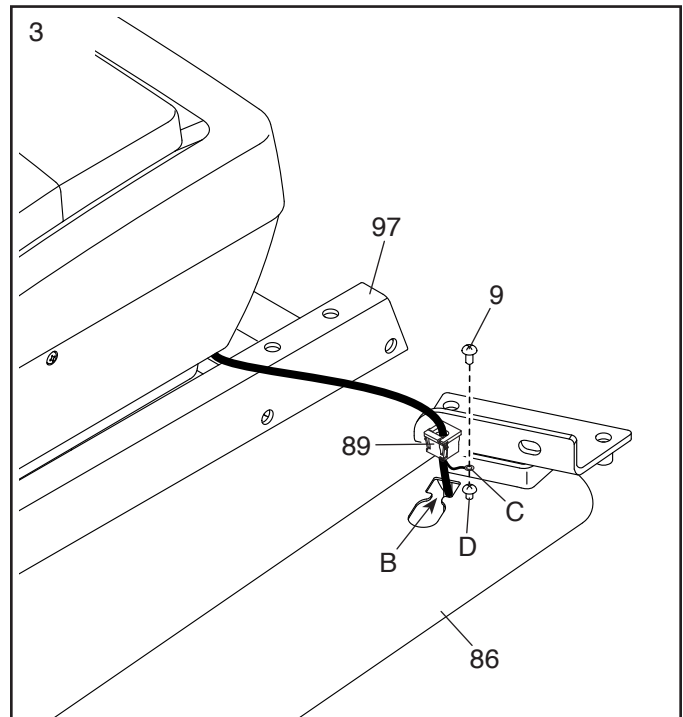

4. Hold the Right Upright (86) against the Base (97). **Make sure not to pinch the Upright Wire (88).**

Insert two 3/8" x 2 3/8" Screws (3) with two 3/8" Star Washers (11) into the top of the bracket on the Right Upright (86). Partially tighten the two Screws into the Base (97); **do not fully tighten the Screws yet.**

Then, partially tighten a 3/8" x 1 1/4" Screw (1) and a 3/8" x 1 3/4" Screw (2) with 3/8" Star Washers (11) into the bottom of the Right Upright (86); **do not fully tighten the Screws yet.**

Attach the Left Upright (not shown) in the same way. Note: There are no wires on the left side.

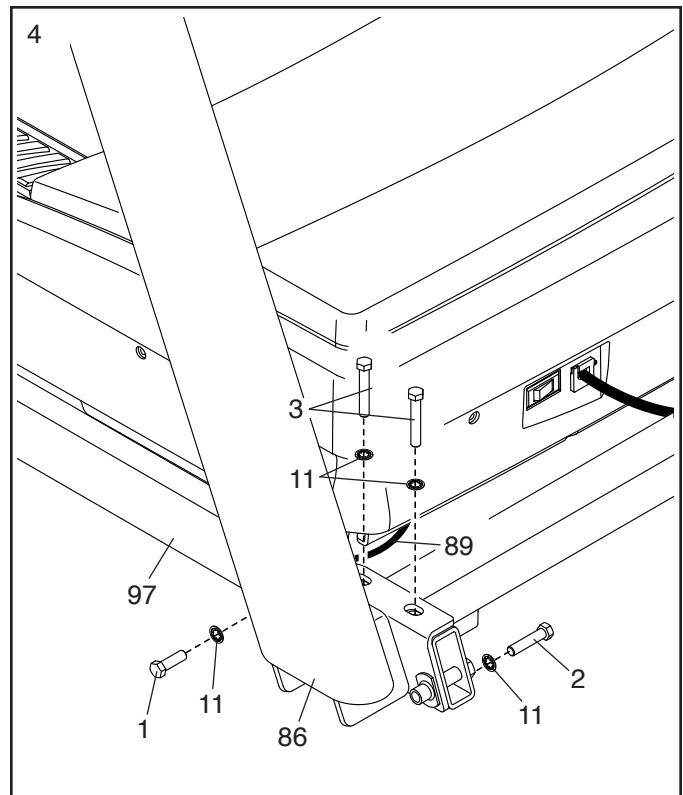

5. Identify the Left and Right Base Covers (93, 92). Slide the Left and Right Base Covers onto the Left and Right Uprights (85, 86) as shown.

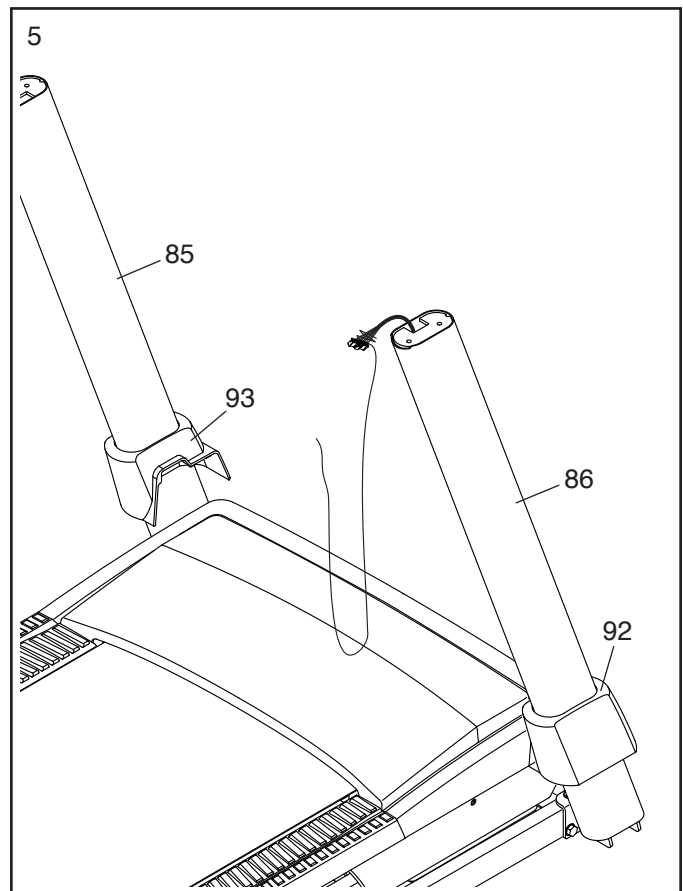

- Identify the Left and Right Handrails (80, 81). Attach the Right Handrail (81) to the Right Upright (86) with two 5/16" x 2 1/4" Screws (7) and two 5/16" Star Washers (12) in the location shown; **start both Screws, and then tighten them. Make sure not to pinch the Upright Wire (88), and make sure that the wire is on the indicated side of the Right Upright.**

Attach the Left Handrail (80) to the Left Upright (85) in the same way. Note: There are no wires on the left side.

Then, remove and discard the indicated screws (E).

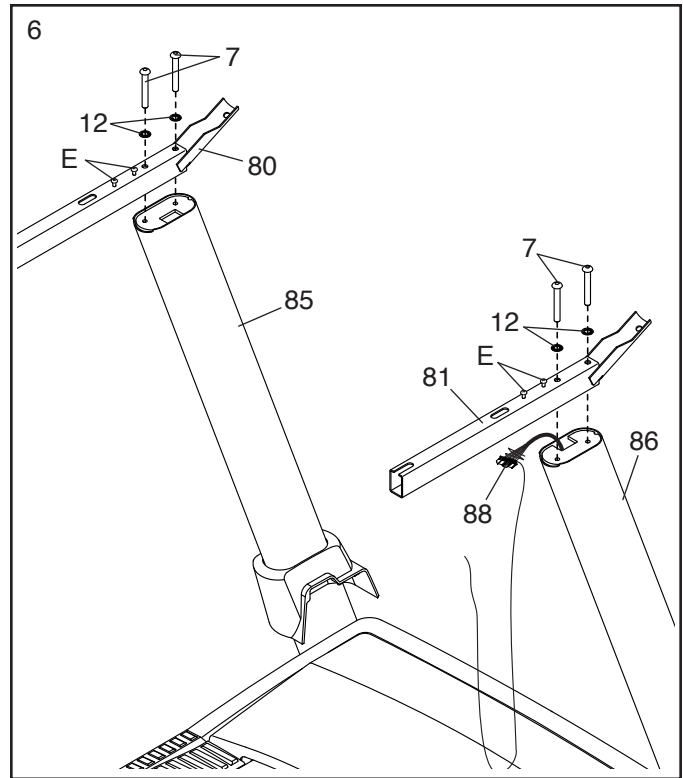

- Set the console assembly (F) face down on a soft surface to avoid scratching the console assembly. Attach the Right and Left Trays (99, 98) with eight #8 x 1/2" Screws (5); **start all eight Screws, and then tighten them. Do not overtighten the Screws.**

Remove and save the four 1/4" x 1/2" Screws (24).

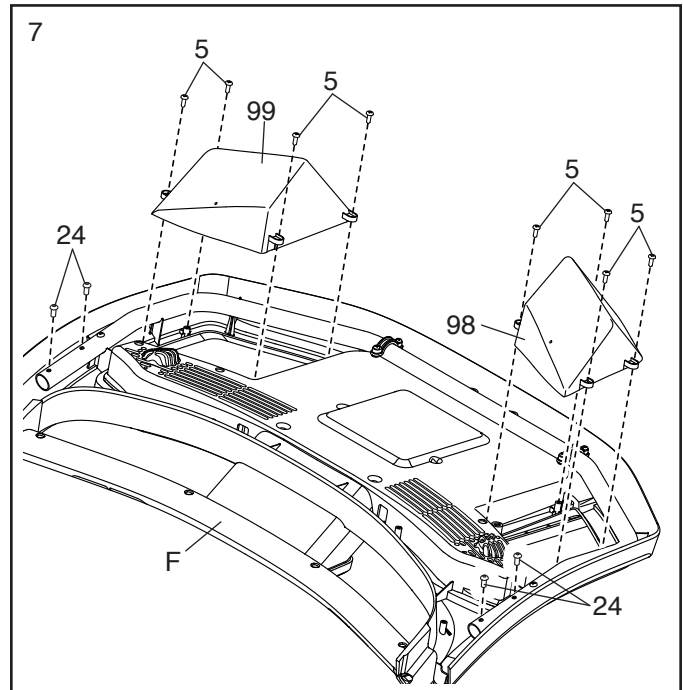

8. With the help of a second person, hold the console assembly (F) near the Right Upright (86).

Next, insert the Upright Wire (88) through the indicated looped tie (G).

Connect the Upright Wire (88) to the wire (H) from the console assembly (F). **The connectors should slide together easily and snap into place.** If they do not, turn one connector and try again.

Then, remove any wire ties (A) from the Upright Wire (88).

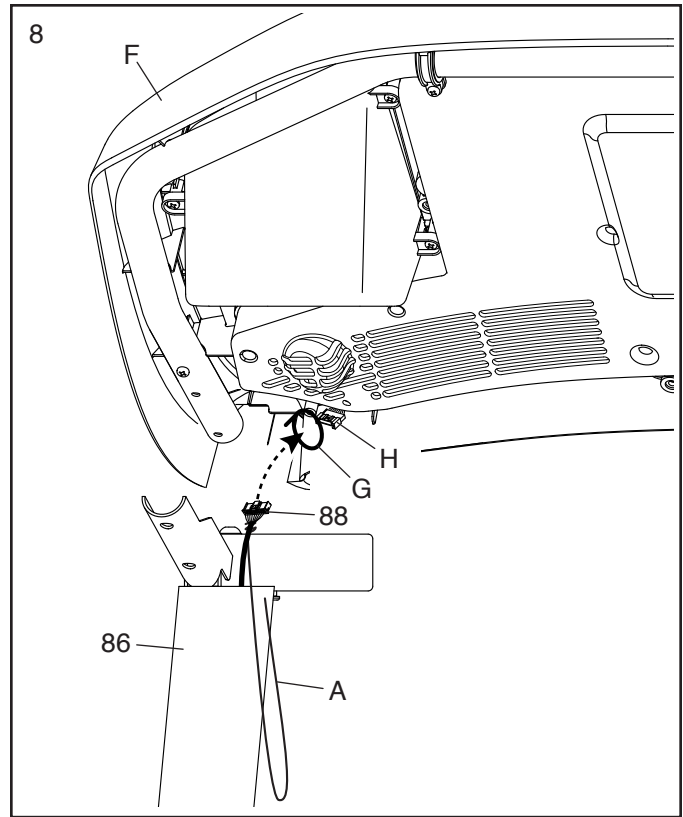

9. Set the console assembly (F) on the Right and Left Handrails (81, 80); **do not pinch any wires.**

Attach the console assembly (F) with the four 1/4" x 1/2" Screws (24) that you removed in step 7 and four 1/4" Star Washers (10); **start all four Screws, and then tighten them.**

Insert the excess Upright Wire (88) into the Right Upright (86). Then, tighten the tie (G) around the Upright Wire and cut off the end of the tie.

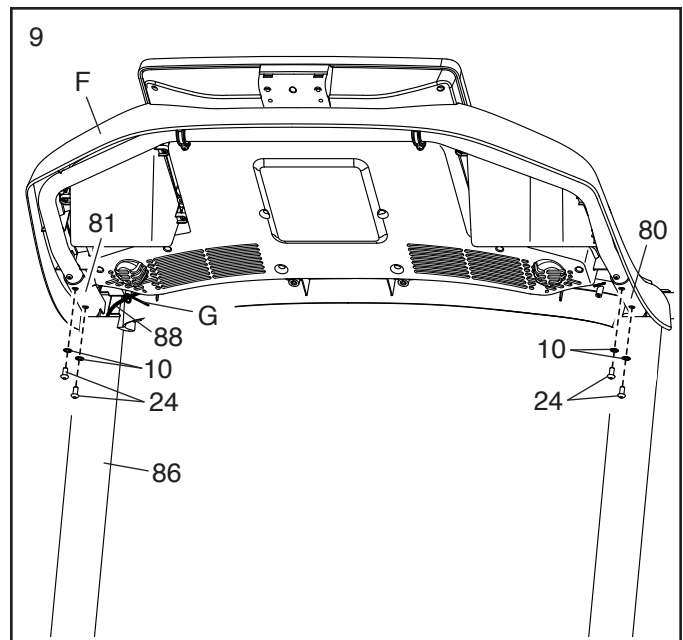

10. **IMPORTANT:** To avoid damaging the Crossbar (87), do not use power tools and do not overtighten the #10 x 3/4" Screws (6).

Attach the Crossbar (87) to the Handrails (80, 81) with four #10 x 3/4" Screws (9) and four 1/4" Star Washers (10); **start all four Screws, and then tighten them.**

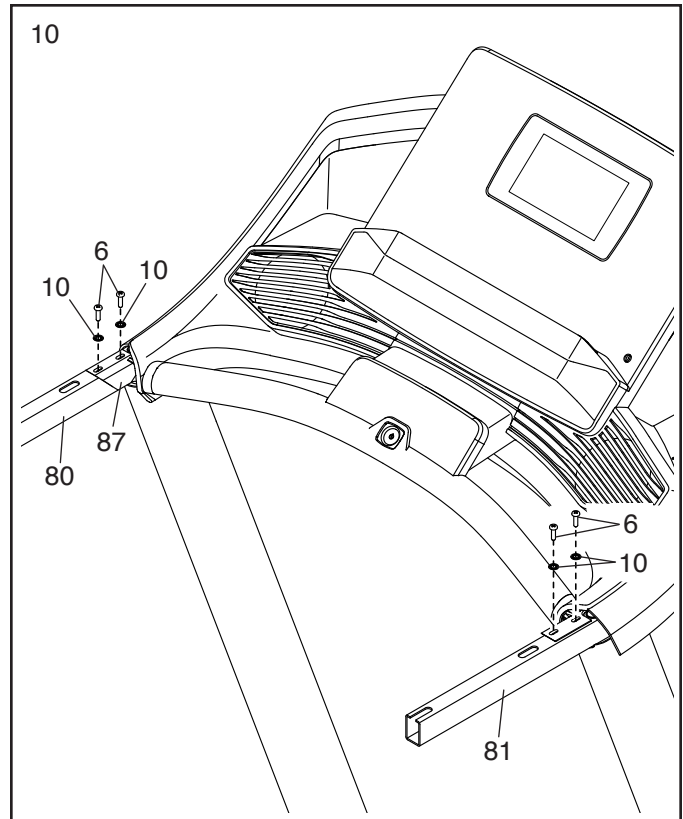

11. Identify the Right Handrail Cover (79). Set the Right Handrail Cover on the Right Handrail (81), and slide the Right Handrail Cover forward until it rests against the console assembly (F).

Next, hold the Right Bottom Handrail Cover (83) on the bottom of the Right Handrail (81) and start four #8 x 3/4" Screws (4) into the bottom of the Right Bottom Handrail Cover; **start all four Screws, and then tighten them.**

Attach the Left Handrail Cover (78) and the Left Bottom Handrail Cover (82) in the same way.

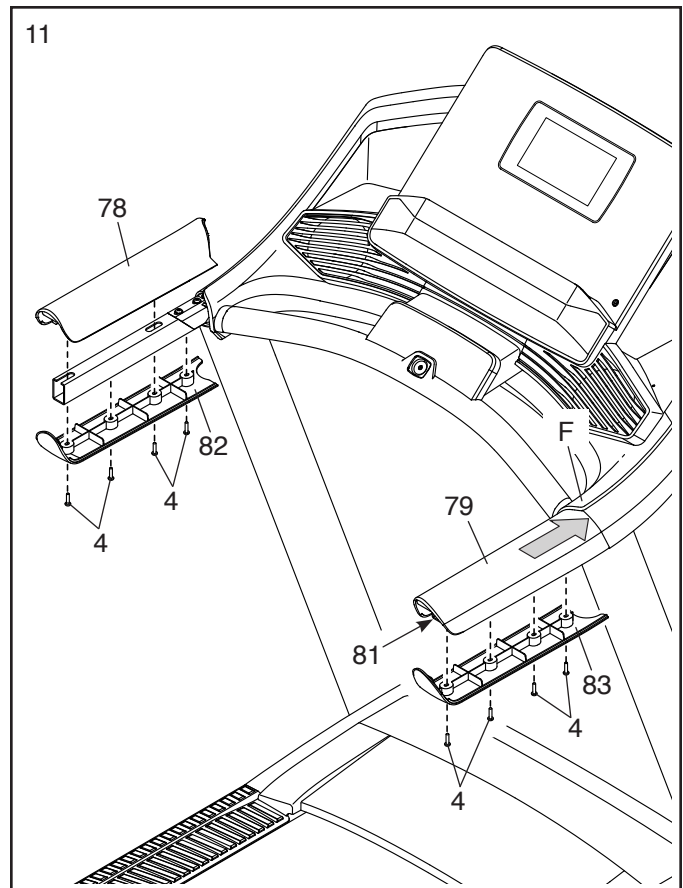

12. **Note: If the treadmill is assembled on a smooth surface, it may roll forward during this step.**

Raise the Frame (60) to the upright position. **IMPORTANT: Do not raise the Frame past the vertical position. Have a second person hold the Frame until step 14 is completed.**

Remove the two 5/16" x 3/4" Screws (8) from the Latch Crossbar (31).

Orient the Latch Crossbar (31) as shown. **Make sure that the "This side toward belt" sticker (I) is facing the treadmill.** Attach the Latch Crossbar to the brackets (J) on the Frame (60) with the two 5/16" x 3/4" Screws (8) and two 5/16" Star Washers (12).

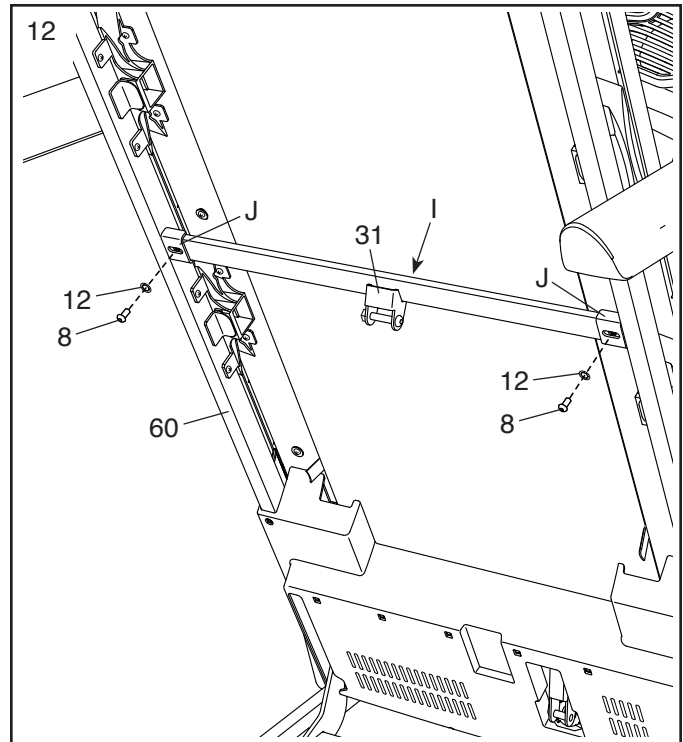

13. Remove the 5/16" Nut (39) and the 5/16" x 1 3/4" Bolt (28) from the bracket on the Base (97).

Next, orient the Storage Latch (35) as shown.

Attach the lower end of the Storage Latch (35) to the bracket on the Base (97) with the 5/16" x 1 3/4" Bolt (28) and the 5/16" Nut (39).

Then, raise the Storage Latch (35) to a vertical position, and remove the tie (K).

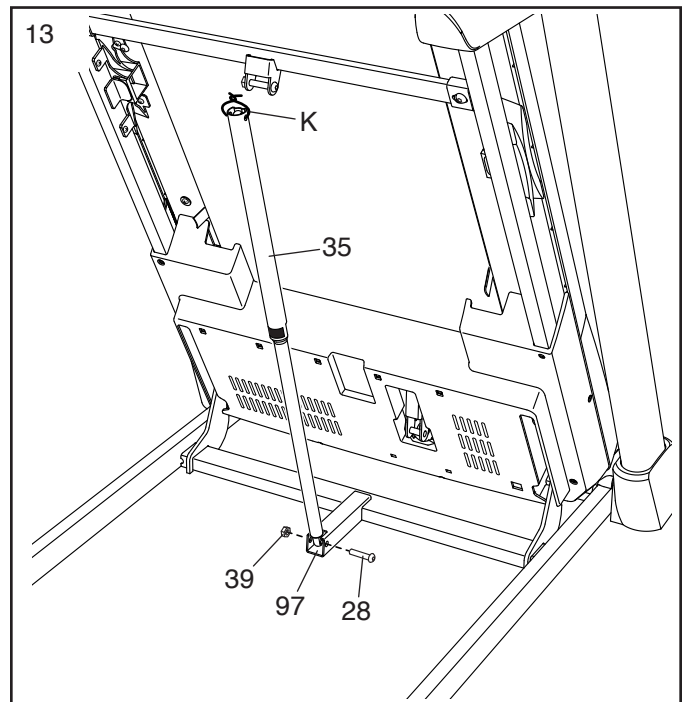

14. Remove the 5/16" Nut (39) and the 5/16" x 2 1/4" Bolt (29) from the bracket on the Latch Crossbar (31).

Align the upper end of the Storage Latch (35) with the bracket on the Latch Crossbar (31), and insert the 5/16" x 2 1/4" Bolt (29) through the bracket and the Storage Latch. **This will push a spacer (L) out of the Storage Latch; discard the spacer.**

Next, tighten the 5/16" Nut (39) onto the 5/16" x 2 1/4" Bolt (29). **Do not overtighten the Nut; the Storage Latch (35) must be able to pivot.**

Then, lower the Frame (60) (see HOW TO LOWER THE TREADMILL FOR USE on page 28).

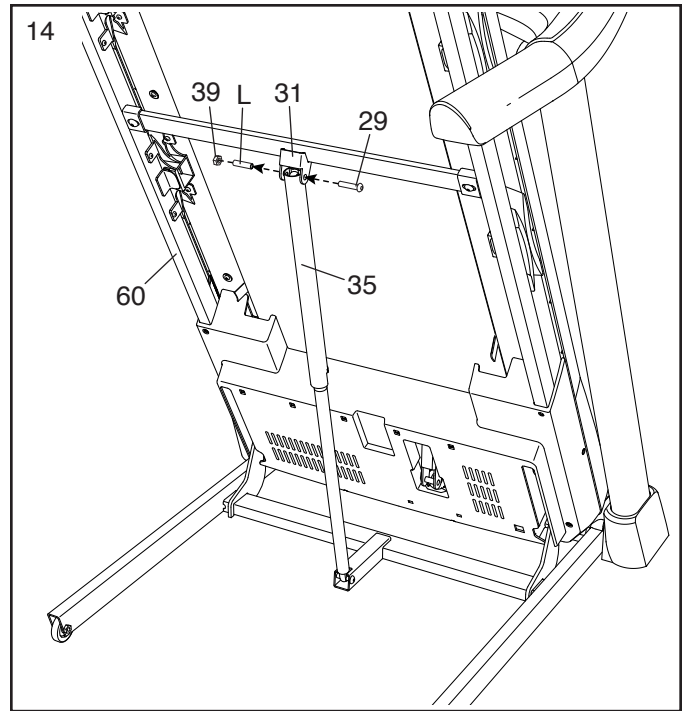

15. **Firmly tighten the four 3/8" x 2 3/8" Screws (3), the two 3/8" x 1 1/4" Screws (1), and the two 3/8" x 1 3/4" Screws (2).**

Next, set the Left Inner Base Cover (95) onto the lower end of the Left Upright (85). Then, slide the Left Base Cover (93) downward and press it onto the Left Inner Base Cover.

Next, set the Right Inner Base Cover (94) onto the lower end of the Right Upright (86). Then, slide the Right Base Cover (92) downward and press it onto the Right Inner Base Cover.

To register your product and activate your warranty today, go to my.proform.com.

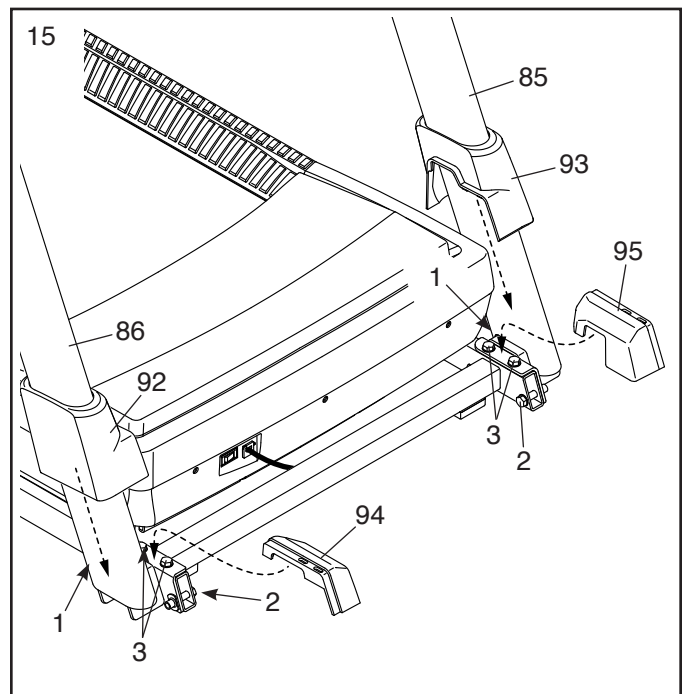

16. **Make sure that all parts are properly tightened before you use the treadmill.** If there are sheets of plastic on the treadmill decals, remove the plastic. To protect the floor or carpet, place a mat under the treadmill. To avoid damage to the console, keep the treadmill out of direct sunlight. Keep the included hex keys in a secure place; one of the hex keys is used to adjust the walking belt (see page 30). Note: Extra hardware may be included.

HOW TO USE THE TREADMILL

HOW TO CONNECT THE POWER CORD

Use a Surge Suppressor

Your treadmill, like other electronic equipment, can be damaged by sudden voltage changes in your home's power. Voltage surges, spikes, and noise interference can result from weather conditions or from other appliances being turned on or off. **To decrease the risk of damaging the treadmill, always use a surge suppressor (A) with the treadmill. To purchase a surge suppressor, see precaution 14 on page 3.**

Use only a surge suppressor (A) that is UL 1449 listed as a transient voltage surge suppressor (TVSS). The surge suppressor must have a UL suppressed voltage rating of 400 volts or less and a minimum surge dissipation of 450 joules. The surge suppressor must also be electrically rated for 120 volts AC and 15 amps. There must be a monitoring light on the surge suppressor to indicate whether it is functioning properly. **Failure to use a properly functioning surge suppressor could result in damage to the control system of the treadmill and serious injury to users.**

Plug in the Power Cord

The treadmill must be grounded. If it should malfunction or break down, grounding provides a path of least resistance for electric current to reduce the risk of electric shock. The treadmill power cord (B) has a plug with a grounding pin (C) (see drawing 1 on this page).

⚠ DANGER: Improper connection of the power cord increases the risk of electric shock. Do not modify the plug—if it will not fit an outlet, have a proper outlet installed by a qualified electrician. If you are unsure whether the treadmill is properly grounded, contact a qualified electrician.

Plug the power cord (B) into a surge suppressor (A), and plug the surge suppressor into an appropriate outlet (D) that is properly installed and grounded in accordance with all local codes and ordinances. **The outlet must be on a nominal 120-volt circuit**

capable of carrying 15 or more amps. To avoid overloading the circuit, do not plug other electrical devices, except for low-power devices such as cell phone chargers, into the surge suppressor or into an outlet on the same circuit. **IMPORTANT: If the treadmill is connected to an AFCI-equipped outlet and your circuit breaker trips repeatedly when the treadmill is used, see the front cover of this manual to purchase an arc filter.**

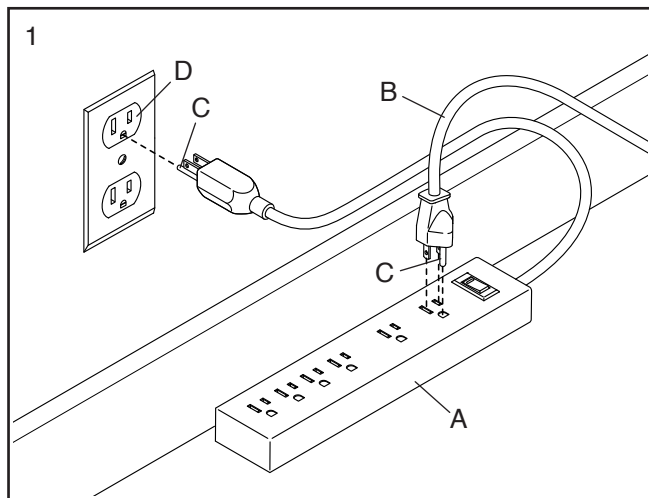

A temporary adapter (E) may be used to connect the surge suppressor (A) to a 2-pole receptacle (F) if a properly grounded outlet is not available.

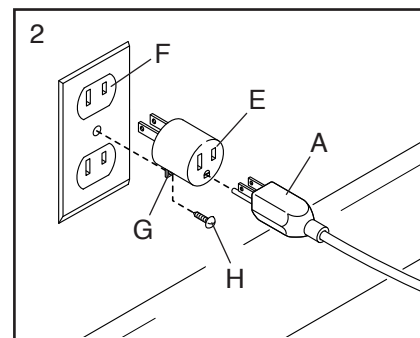

The lug (G) or wire extending from the adapter must be connected with a metal screw (H) to a permanent ground such as a properly grounded outlet box cover. **Some 2-pole receptacle outlet box covers are not grounded. Before using an adapter, contact a qualified electrician to determine whether the outlet box cover is grounded. The temporary adapter should be used only until a properly grounded outlet can be installed by a qualified electrician.**

CONSOLE DIAGRAM

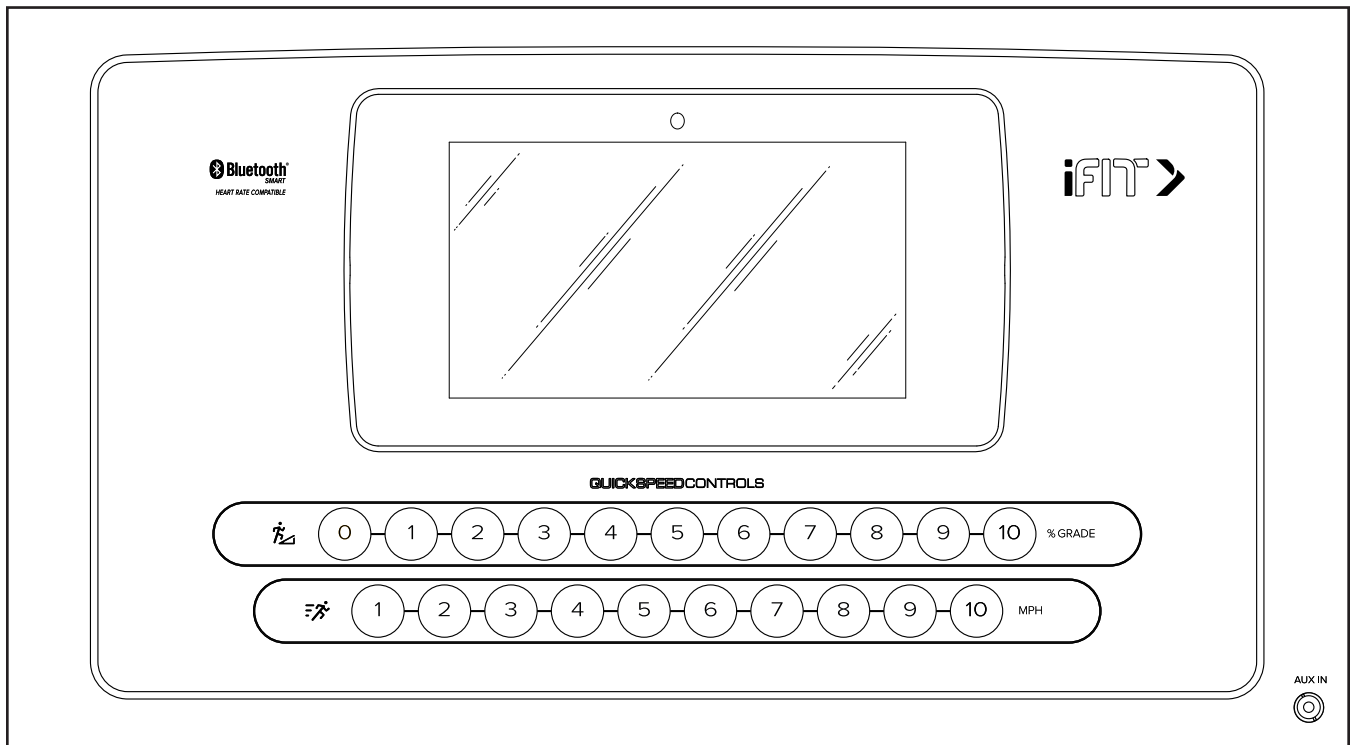

FEATURES OF THE CONSOLE

The advanced treadmill console offers a selection of features designed to make your workouts more effective and enjoyable.

The console features wireless technology that enables the console to connect to iFit. With iFit, you can access a large and varied workout library, create your own workouts, track your workout results, and access many other features.

When you use the manual mode, you can change the speed and incline of the treadmill with the touch of a button. As you exercise, the console will display instant exercise feedback. You can even measure your heart rate using a compatible Bluetooth® heart rate monitor.

See page 26 for information about purchasing an optional heart rate monitor.

In addition, the console features a selection of workouts. Each workout automatically controls the speed and incline of the treadmill as it guides you through an effective exercise session.

You can even listen to your favorite workout music or audio books with the console's sound system while you exercise.

To turn on the power, see page 18. To learn how to use the touch screen, see page 18. To set up the console, see page 19.

HOW TO TURN ON THE POWER

IMPORTANT: If the treadmill has been exposed to cold temperatures, allow it to warm to room temperature before you turn on the power. If you do not do this, you may damage the console displays or other electrical components.

Plug in the power cord (see page 16). Next, locate the power switch on the treadmill frame near the power cord. Press the power switch into the reset position (I).

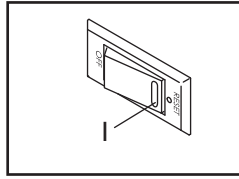

Next, stand on the foot rails of the treadmill. Locate the clip (J) attached to the key (K), and slide the clip securely onto the waistband of your clothes. Then, insert the key into the console.

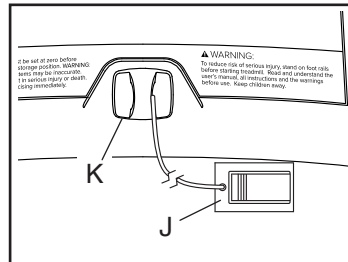

insert the key into the console. **Note:** It may take some time for the console to be ready for use. **IMPORTANT:** In an emergency, the key can be pulled from the console, causing the walking belt to slow to a stop. Test the clip by carefully taking a few steps backward; if the key is not pulled from the console, adjust the position of the clip.

Note: The console can display speed and distance in either miles or kilometers. To find which unit of measurement is selected, see HOW TO CHANGE CONSOLE SETTINGS on page 24. For simplicity, all instructions in this section refer to miles.

HOW TO USE THE TOUCH SCREEN

The console features a tablet with a full-color touch screen. The following information will help you become familiar with the tablet's advanced technology:

- The console functions similarly to other tablets. You can slide or flick your finger against the screen to move certain images on the screen, such as the displays in a workout (see step 5 on page 20).
- The screen is not pressure sensitive. You do not need to press hard on the screen.
- To type information into a text box, touch the text box to view the keyboard. To use numbers or other characters on the keyboard, touch the ?123 button. To view more characters, touch the ~[< button. Touch the ?123 button again to return to the number keyboard. To return to the letter keyboard, touch the ABC button. To use a capital character, touch the button with an upward-facing arrow. To use multiple capital characters, touch and hold the arrow button. To return to the lowercase keyboard, touch the arrow button again. To clear the last character, touch the button with a backward-facing arrow and an X.

HOW TO SET UP THE CONSOLE

Before using the treadmill for the first time, set up the console.

1. Connect to your wireless network.

To access the internet, download iFit workouts, and use several other features of the console, the console must be connected to a wireless network.

Follow the prompts on the screen to connect the console to your wireless network.

2. Customize settings.

Fill in the form on the screen to set the console to display the desired unit of measurement and your time zone. Note: If you need to change these settings later, see HOW TO CHANGE CONSOLE SETTINGS on page 24.

3. Log into or create an iFit account.

Provide your email address, and follow the prompts on the screen to sign up for or log into your iFit account.

4. Tour the console.

The first time you turn on the treadmill, dialogue boxes on the screen will guide you through the features of the console.

5. Check for firmware updates.

First, touch your name or *Hello* on the screen, and then touch *Settings*. Next, select the maintenance section. Then, touch *Update* to check for firmware updates using your wireless network. See step 5 on page 24 for more information.

6. Calibrate the incline system.

First, touch your name or *Hello* on the screen. Next, select the settings main menu. Then, select the maintenance section, touch *Calibrate Incline*, and then touch *Begin* to calibrate the incline system. See step 6 on page 24 for more information.

The console is now ready for you to begin working out. The following pages explain the various workouts and other features that the console offers.

To use the manual mode, see page 20. **To use a map workout**, see page 21. **To use a draw your own map workout**, see page 22. **To use a distance or time workout**, see page 23.

To view or change console settings, see page 24. **To connect to a wireless network**, see page 25. **To use the sound system**, see page 26.

IMPORTANT: If there are sheets of plastic on the console, remove the plastic. To prevent damage to the walking platform, wear clean athletic shoes while using the treadmill. The first time you use the treadmill, observe the alignment of the walking belt, and center the walking belt if necessary (see page 30).

HOW TO USE THE MANUAL MODE

1. Insert the key into the console.

See HOW TO TURN ON THE POWER on page 18. **Note: It may take some time for the console to be ready for use.**

2. Select the main menu.

When you turn on the power, the main menu will appear after the console boots up. If you are in a workout or the settings menu, touch the back arrow or the x on the screen to return to the main menu.

Note: If you plan to use a compatible heart rate monitor with the console while you exercise, you must put on the heart rate monitor **before you start the walking belt**. The console will automatically search for the heart rate monitor for 30 seconds when you start the walking belt at the beginning of each workout.

3. Start the walking belt and adjust the speed.

Touch *Manual Start* on the screen or press the Start button on the console to start the walking belt. The walking belt will begin to move at a low speed. As you exercise, change the speed of the walking belt as desired by pressing the Speed increase and decrease buttons. Each time you press one of the buttons, the speed setting will change by 0.1 mph; if you hold down the button, the speed setting will change in increments of 0.5 mph.

If you press one of the numbered speed buttons, the walking belt will gradually change speed until it reaches the selected speed setting.

To stop the walking belt, press the Stop button or tap the center of the screen. To restart the walking belt, press the Start button.

4. Change the incline of the treadmill as desired.

To change the incline of the treadmill, press the Incline increase and decrease buttons or one of the numbered incline buttons. Each time you press one of the buttons, the incline will gradually change until it reaches the selected incline setting.

IMPORTANT: The first time you use the treadmill, you must calibrate the incline system (see step 6 on page 24).

5. Monitor your progress with the display modes.

While you exercise, a selection of workout information will be displayed:

- The incline level of the treadmill
- The elapsed time
- The approximate number of calories you have burned
- The distance that you have walked or run
- The speed of the walking belt

Additional information is also available. To view or browse additional statistics and charts, swipe down from the top of the screen. You can also touch the + symbol on the screen to view stats or charts.

NOTE: To record heart rate information, a compatible heart rate monitor must be in use (see page 26).

If desired, adjust the volume by pressing the volume buttons on the console.

To pause the workout, tap the screen or press the Stop button on the console. To continue the workout, touch the play icon on the screen or press the Start button.

6. Turn on the fan if desired.

The fan features several speed settings. Press the Fan buttons repeatedly to select a fan speed or to turn the fan on or off.

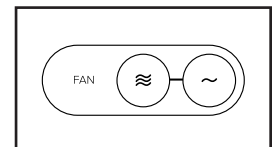

7. When you are finished exercising, remove the key from the console.

Step onto the foot rails and press the Stop button on the console or tap on the screen. Then, touch the stop icon on the screen or press the Stop button again. A workout summary will appear on the screen. If you wish to save your workout for future use, you can add it as a favorite by touching the heart button on the screen. You may also be able to either save or publish your results using one of the options on the screen. Touch *Finish* to exit to the main menu. Then, remove the key from the console and put it in a secure place.

When you are finished using the treadmill, press the power switch into the off position and unplug the power cord. **IMPORTANT: If you do not do this, the treadmill's electrical components may wear prematurely.**

HOW TO USE A MAP WORKOUT

Note: To use a map workout, the console must be connected to a wireless network (see HOW TO CONNECT TO A WIRELESS NETWORK on page 25).

1. Insert the key into the console.

See HOW TO TURN ON THE POWER on page 18.

2. Select the main menu or the workout library.

Touch *Home* or *Browse* on the screen to select either the main menu or the workout library.

3. Select a workout.

To select a workout, touch the desired option on the screen. Note: The featured map workouts on your console will change periodically. If you wish to save your workout for future use, you can add it as a favorite by touching the heart button on the screen. You may also be able to either save or publish your results using one of the options on the screen. To draw your own map workout, see page 22.

The screen will show the duration and distance of the workout and the approximate number of calories you will burn during the workout.

4. Start the workout.

Touch *Start* to start the workout. A moment after you touch the button, the walking belt will begin to move. Hold the handrails and begin walking.

During the workout, a map on the screen will show your progress.

The workout will function in the same way as the manual mode (see page 20).

When you reach the end of the workout, the walking belt will slow to a stop, and a workout summary will appear on the screen. After you view the workout summary, touch *Finish* to return to the main menu. You may also be able to either save or publish your results using one of the options on the screen.

5. Monitor your progress with the display modes.

See step 5 on page 20.

6. Turn on the fan if desired.

See step 6 on page 20.

7. When you are finished exercising, remove the key from the console.

See step 7 at the left.

HOW TO USE A DRAW YOUR OWN MAP WORKOUT

Note: To use a draw your own map workout, the console must be connected to a wireless network (see HOW TO CONNECT TO A WIRELESS NETWORK on page 25).

1. Insert the key into the console.

See HOW TO TURN ON THE POWER on page 18.

2. Select a draw your own map workout.

To select a draw your own map workout, touch *Create* on the screen.

3. Draw your map.

Navigate to the area on the map where you want to draw your workout by sliding your fingers on the screen. Tap the screen to add the start point for your workout. Then, tap the screen to add the end point for your workout. Note: If you want to start and end the workout at the same point, use the *Loop* or *Out & Back* options. You can also select whether you want your workout to snap to the road.

If you make a mistake, you can touch *Undo*.

The screen will display the elevation and distance statistics for your workout. If desired, you can change the default speed.

4. Save your workout.

Touch *Save New Workout* on the screen. If desired, change the title of the workout or add a description, and then press the > symbol on the screen.

5. Start the workout.

Touch *Start* on the screen to start the workout. A moment after you touch the button, the walking belt will begin to move. Hold the handrails and begin walking. See step 4 on page 21 for more information.

6. Monitor your progress with the display modes.

See step 5 on page 20.

7. Turn on the fan if desired.

See step 6 on page 20.

8. When you are finished exercising, remove the key from the console.

See step 7 on page 21.

HOW TO USE A DISTANCE OR TIME WORKOUT

Note: To use a distance or time workout, the console must be connected to a wireless network (see HOW TO CONNECT TO A WIRELESS NETWORK on page 25). An iFit account is also required.

1. Add workouts to your schedule on iFit.com.

On your computer, smartphone, tablet, or other device, open an internet browser, go to iFit.com, and sign in to your iFit account.

Next, navigate to Menu > Library on the website. Browse the workout programs in the library and join the desired workouts.

Then, navigate to Menu > Schedule to view your schedule. All of the workouts that you have joined will appear on your schedule; you can arrange or delete the workouts on your schedule as desired.

Take time to explore the iFit.com website before you log out.

2. Insert the key into the console.

See HOW TO TURN ON THE POWER on page 18.

3. Select the main menu.

See step 2 on page 20.

4. Log in to your iFit account.

If you have not already done so, touch *Login* to log in to your iFit account. The screen will ask for your iFit.com username and password. Enter them and touch *Submit*. Touch *Cancel* to exit the login screen.

5. Select a distance or time workout that you have previously added to your schedule on iFit.com.

Touch the calendar icon to download a distance or time workout from your schedule.

Note: Before workouts will download, you must add them to your schedule on iFit.com.

When you select a distance or time workout, the screen will show the name, the estimated duration, and the distance of the workout.

6. Start the workout.

Touch the Start button to start the workout. A moment after you touch the button, the walking belt will begin to move. Hold the handrails and begin walking.

When you reach the end of the workout, the walking belt will slow to a stop, and a workout summary will appear on the screen. After you view the workout summary, touch the Finish button to return to the main menu. You may also be able to either save or publish your results using one of the options on the screen.

7. Monitor your progress with the display modes.

See step 5 on page 20. The screen will show the elapsed distance or time and the remaining distance or time.

8. Turn on the fan if desired.

See step 6 on page 20.

9. When you are finished exercising, remove the key from the console.

See step 7 on page 21.

For more information about iFit, go to iFit.com.

HOW TO CHANGE CONSOLE SETTINGS

IMPORTANT: Some of the settings and features described may not be enabled. Occasionally, a firmware update may cause your console to function slightly differently.

1. Select the settings main menu.

First, turn on the power and insert the key into the console (see HOW TO TURN ON THE POWER on page 18). Note: It may take a few moments for the console to be ready for use.

Next, select the main menu. When you turn on the console, the main menu will appear on the screen after the console boots up. If you are in a workout, touch the screen, touch *Pause*, touch *End*, and then touch *Finish* to return to the main menu.

Next, touch your name or *Hello* on the screen, and then touch *Settings*. The settings menu will appear on the screen.

2. Navigate the settings menus and change settings as desired.

Slide or flick the screen to scroll upward or downward if necessary. To view a settings menu, simply touch the menu name. To exit a menu, touch the back button (arrow symbol). You may be able to view and change settings in the following settings menus:

Account

- My Profile
- In Workout
- Manage Accounts

Equipment

- Equipment Info
- Equipment Settings
- Maintenance
- Wi-Fi

About

- Legal

3. Customize the unit of measurement and other settings.

To customize the unit of measurement, the time zone, or other settings, touch *Equipment Settings*, and then touch the desired settings.

The console can display speed and distance in either standard or metric units of measurement.

4. View machine information.

Touch *Equipment Info*, and then touch *Machine Info* to view information about your treadmill.

5. Update the console firmware.

For the best results, regularly check for firmware updates. Touch *Maintenance*, and then touch *Update* to check for firmware updates using your wireless network. The update will begin automatically. **IMPORTANT: To avoid damaging the console, do not turn off or unplug the treadmill while the firmware is being updated.**

The screen will show the progress of the update. When the update is complete, the treadmill will turn off and then turn back on. If it does not, use the power switch (see HOW TO TURN ON THE POWER on page 18) to turn the treadmill off, wait for a few seconds, and then turn it back on again. Note: It may take a few minutes for the console to be ready for use.

Note: Occasionally, a firmware update may cause the console to function slightly differently. These updates are always designed to improve your exercise experience.

6. Calibrate the incline system of the treadmill.

Touch *Calibrate Incline*, and then touch *Begin* to calibrate the incline system. The treadmill will automatically rise to the maximum incline level, and then return to the starting position. This will calibrate the incline system. Touch *Cancel* to return to the Maintenance section. When the incline system is calibrated, touch *Finish*.

IMPORTANT: Keep pets, feet, and other objects away from the treadmill while the incline system is calibrating. In an emergency, pull the key from the console to stop the incline calibration.

7. Exit the settings main menu.

If you are in a settings menu, touch the back arrow. Then, touch the close button (x symbol) to exit the settings main menu.

HOW TO CONNECT TO A WIRELESS NETWORK

The console is Wi-Fi enabled, allowing you to set up a wireless network connection.

1. Select the main menu.

See step 2 on page 20.

2. Select the wireless network menu.

Touch your name or *Hello* on the screen, and then touch the Wi-Fi® symbol to enter the wireless network menu.

3. Enable Wi-Fi.

Make sure that the Wi-Fi is enabled. If it is not, touch the Wi-Fi toggle to enable a wireless connection.

4. Set up and manage a wireless network connection.

When Wi-Fi is enabled, the screen will show a list of available networks. Note: It may take several seconds for the list of wireless networks to appear.

Note: You must have your own wireless network and an 802.11b/g/n router with SSID broadcast enabled (hidden networks are not supported).

When a list of networks appears, touch the desired network. Note: You will need to know your network name (SSID). If your network has a password, you will also need to know the password.

An information box will ask if you want to connect to the wireless network. Touch *Connect* to connect to the network or touch *Cancel* to return to the list of networks. If the network has a password, touch the password entry box. A keyboard will appear on the screen. To view the password as you type it, touch the *Show Password* checkbox.

To use the keyboard, see HOW TO USE THE TOUCH SCREEN on page 18.

When the console is connected to your wireless network, a checkmark will appear next to the wireless network name. Then, touch the back arrow on the screen to return to the wireless network menu.

To disconnect from a wireless network, touch and hold the name of the wireless network and then touch *Forget Network*.

If you are having problems connecting to an encrypted network, make sure that your password is correct. Note: Passwords are case-sensitive.

Note: The console supports unsecured and secured (WEP, WPA™, and WPA2™) encryption. A broadband connection is recommended; performance depends on connection speed.

Note: If you have questions after following these instructions, go to support.iFit.com for assistance.

5. Exit the wireless network menu.

To exit the wireless network menu, touch the back arrow on the screen.

HOW TO USE THE SOUND SYSTEM

To play music or audio books through the console sound system while you exercise, plug a 3.5 mm male to 3.5 mm male audio cable (not included) into the jack on the console and into a jack on your personal audio player; **make sure that the audio cable is fully plugged in. Note: To purchase an audio cable, see your local electronics store.**

Next, press the play button on your personal audio player. Adjust the volume level using the volume increase and decrease buttons on the console or the volume control on your personal audio player.

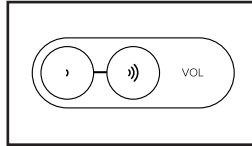

THE OPTIONAL TABLET HOLDER

The optional tablet holder (L) will hold your tablet securely in place and enable you to use your tablet while you exercise. The optional tablet holder is designed for use with most full-size tablets.

To purchase a tablet holder, please see the front cover of this manual.

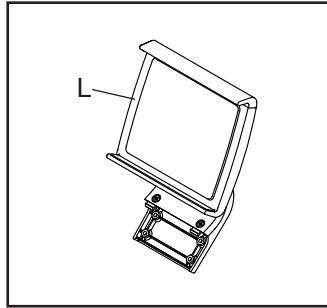

THE OPTIONAL HEART RATE MONITOR

Whether your goal is to burn fat or to strengthen your cardiovascular system, the key to achieving the best results is to maintain the proper heart rate during your workouts. The optional chest heart rate monitor will enable you to continuously monitor your heart rate while you exercise, helping you to reach your personal fitness goals. **To purchase a heart rate monitor, please see the front cover of this manual.**

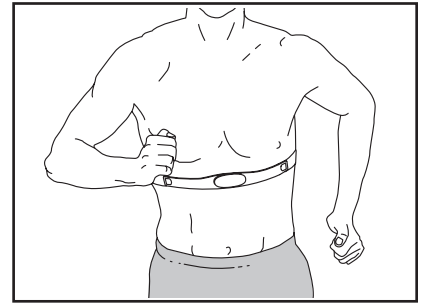

Note: The console is compatible with Bluetooth Smart heart rate monitors.

FCC INFORMATION

This console has been tested and found to comply with the limits for a Class B digital device, pursuant to part 15 of the FCC Rules. These limits are designed to provide reasonable protection against harmful interference in a residential installation. This equipment generates, uses, and can radiate radio frequency energy and, if not installed and used in accordance with the instructions, may cause harmful interference to radio communications. However, there is no guarantee that interference will not occur in a particular installation. If this equipment does cause harmful interference to radio or television reception, which can be determined by turning the equipment off and on, try to correct the interference by one or more of the following measures:

- Reorient or relocate the receiving antenna.
- Increase the separation between the equipment and the receiver.
- Connect the equipment into an outlet on a circuit different from that to which the receiver is connected.
- Consult the dealer or an experienced radio/TV technician for help.

FCC CAUTION: To assure continued compliance, use only shielded interface cables when connecting to computer or peripheral devices. Changes or modifications not expressly approved by the party responsible for compliance could void the user's authority to operate this equipment.

IMPORTANT: To satisfy exposure compliance requirements, the antenna and transmitter in the console must be at least 8 in. (20 cm) from all persons and must not be near or connected to any other antenna or transmitter.

Note: The console contains either FCC ID: OMC402546.

HOW TO FOLD AND MOVE THE TREADMILL

HOW TO FOLD THE TREADMILL

To avoid damaging the treadmill, adjust the incline to zero before you fold the treadmill. Then, remove the key and unplug the power cord. **CAUTION:** You must be able to safely lift 45 lbs. (20 kg) to raise, lower, or move the treadmill.

1. Hold the metal frame (A) firmly in the location shown by the arrow below. **CAUTION: Do not hold the frame by the plastic foot rails. Bend your legs and keep your back straight.**

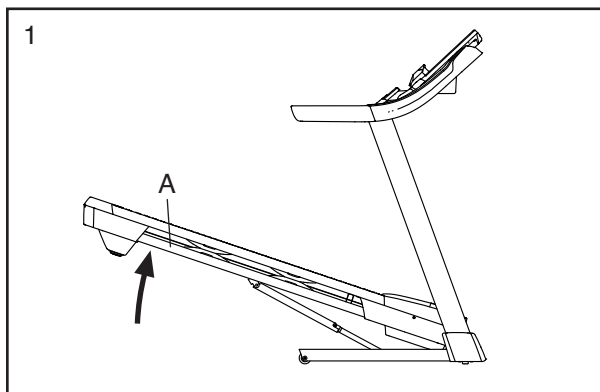

2. Raise the frame (A) until the storage latch (B) locks in the storage position. **CAUTION: Make sure that the storage latch locks.**

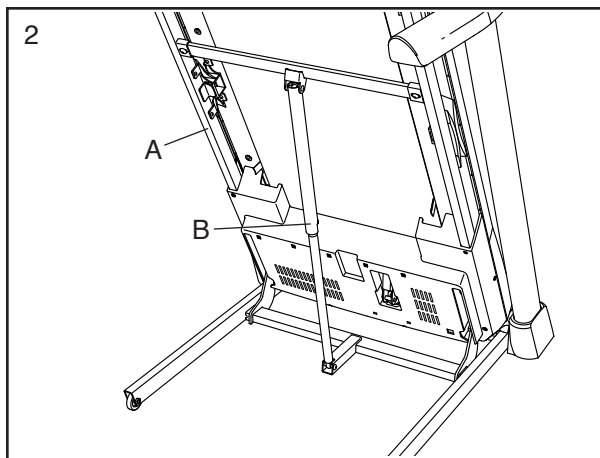

To protect the floor or carpet, place a mat under the treadmill. Keep the treadmill out of direct sunlight. Do not leave the treadmill in the storage position in temperatures above 85°F (30°C).

HOW TO MOVE THE TREADMILL

Before moving the treadmill, fold it as described at the left. **CAUTION: Make sure that the storage latch is in the locked position. Moving the treadmill may require two people.**

1. Hold the frame (A) and one of the handrails (C), and place one foot against a wheel (D).

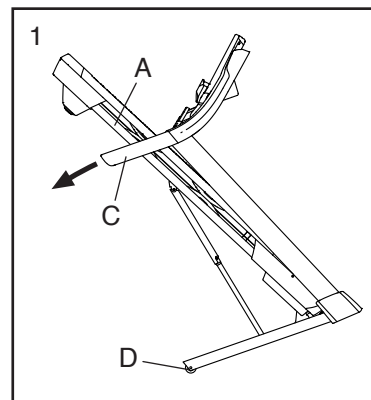

2. Pull back on the handrail until the treadmill will roll on the wheels, and carefully move it to the desired location. **CAUTION: Do not move the treadmill without tipping it back, do not pull on the frame, and do not move the treadmill over an uneven surface.**
3. Place one foot against a wheel, and carefully lower the treadmill.

HOW TO LOWER THE TREADMILL FOR USE

1. Push the upper end of the frame forward, and gently press the upper part of the storage latch with your foot at the same time.
2. While pressing the storage latch with your foot, pull the upper end of the frame toward yourself.
3. Step back and let the frame lower to the floor.

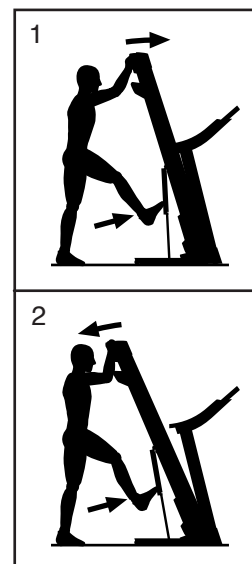

MAINTENANCE AND TROUBLESHOOTING

MAINTENANCE

Regular maintenance is important for optimal performance and to reduce wear. Inspect and properly tighten all parts each time the treadmill is used. Replace any worn parts immediately.

Regularly clean the treadmill and keep the walking belt clean and dry. First, **press the power switch into the off position and unplug the power cord**. Wipe exterior parts of the treadmill with a damp cloth and a small amount of mild soap. **IMPORTANT: Do not spray liquids directly onto the treadmill. To avoid damage to the console, keep liquids away from the console.** Then, thoroughly dry the treadmill with a soft towel.

TROUBLESHOOTING

Most treadmill problems can be solved by following the simple steps below. Find the symptom that applies, and follow the steps listed. If further assistance is needed, see the front cover of this manual.

SYMPTOM: The power does not turn on

- a. Make sure that the power cord is plugged into a surge suppressor and that the surge suppressor is plugged into a properly grounded outlet (see page 16). Use only a surge suppressor that meets all of the specifications described on page 16. **IMPORTANT: If the treadmill is connected to an AFCI-equipped outlet and your circuit breaker trips repeatedly when the treadmill is used, see the front cover of this manual to purchase an arc filter.**
- b. After the power cord has been plugged in, make sure that the key is inserted into the console.

- c. Check the power switch located on the treadmill frame near the power cord. If the switch protrudes as shown (A), the switch has tripped. To reset the power switch, wait for five minutes and then press the switch back in (B).

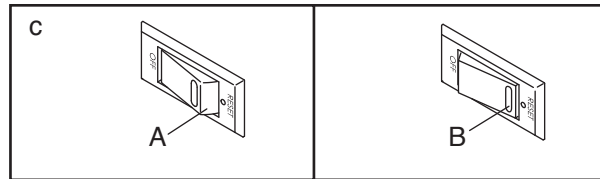

SYMPTOM: The power turns off during use

- a. Check the power switch (see drawing c above). If the switch has tripped, wait for five minutes and then press the switch back in.
- b. Make sure that the power cord is plugged in. If the power cord is plugged in, unplug it, wait for five minutes, and then plug it back in.
- c. Remove the key from the console, and then reinsert it.
- d. If the treadmill still will not run, please see the front cover of this manual.

SYMPTOM: The incline of the treadmill does not change correctly

- a. See step 6 on page 24 to calibrate the incline system.

SYMPTOM: The walking belt slows when walked on

- a. Use only a surge suppressor that meets all of the specifications described on page 16.
- b. If the walking belt is overtightened, treadmill performance may decrease and the walking belt may become damaged. Remove the key and **UNPLUG THE POWER CORD**. Using the hex key, turn both idler roller screws (A) counterclockwise, 1/4 of a turn. When the walking belt is properly tightened, you should be able to lift each edge of the walking belt 2 to 3 in. (5 to 7 cm) off the walking platform. Be careful to keep the walking belt centered. Then, plug in the power cord, insert the key, and walk on the treadmill for a few minutes. Repeat until the walking belt is properly tightened.

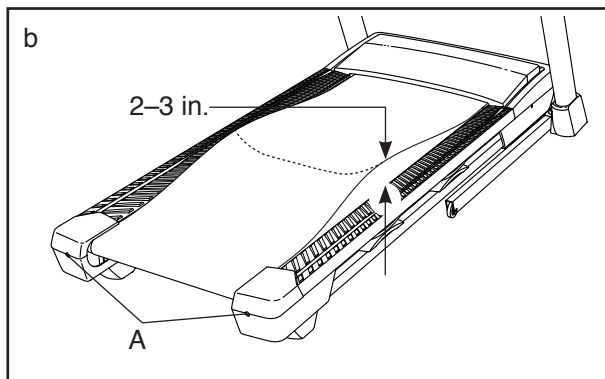

- c. Your treadmill features a walking belt coated with high-performance lubricant. **IMPORTANT: Never apply silicone spray or other substances to the walking belt or the walking platform unless instructed to do so by an authorized service representative. Such substances may deteriorate the walking belt and cause excessive wear.** If you suspect that the walking belt needs more lubricant, see the front cover of this manual.
- d. If the walking belt still slows when walked on, see the front cover of this manual.

SYMPTOM: The walking belt is off-center or slips when walked on

- a. **If the walking belt is off-center**, first remove the key and **UNPLUG THE POWER CORD**. **If the walking belt has shifted to the left**, use the hex key to turn the left idler roller screw clockwise 1/2 of a turn; **if the walking belt has shifted to the right**, turn the left idler roller screw counterclockwise 1/2 of a turn. Be careful not to overtighten the walking belt. Then, plug in the power cord, insert the key, and walk on the treadmill for a few minutes. Repeat until the walking belt is centered.

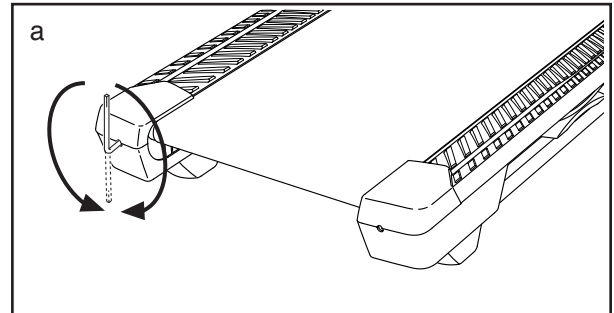

- b. **If the walking belt slips when walked on**, first remove the key and **UNPLUG THE POWER CORD**. Using the hex key, turn both idler roller screws clockwise, 1/4 of a turn. When the walking belt is correctly tightened, you should be able to lift each edge of the walking belt 2 to 3 in. (5 to 7 cm) off the walking platform. Be careful to keep the walking belt centered. Then, plug in the power cord, insert the key, and walk on the treadmill for a few minutes. Repeat until the walking belt is properly tightened.

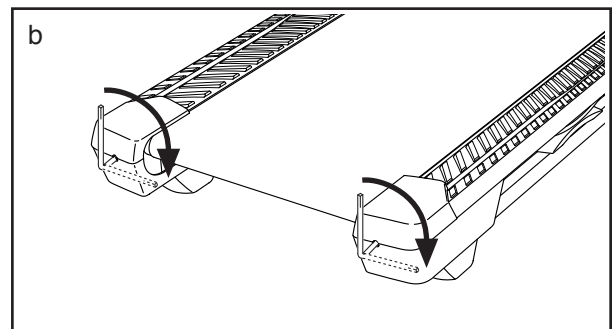

SYMPTOM: The displays of the console do not function properly

- a. If the console does not boot up properly, or if the console freezes and does not respond, reset the console to the factory default settings.
IMPORTANT: Doing this will erase all the custom settings you have made to the console. Resetting the console requires two people. First, press the power switch into the off position. Next, locate the small reset opening (D) on the right side of the console. Using a bent paper clip (E), press and hold the reset button inside the opening, and have a second person press the power switch into the on (reset) position. Continue holding the reset button (D) until the console turns on. When the reset operation is complete, the console will turn off and then turn back on. If it does not, use the power switch to turn the treadmill off and then on again. Once the console turns on, check for firmware updates (see step 5 on page 24). Note: It may take a few minutes for the console to be ready for use.

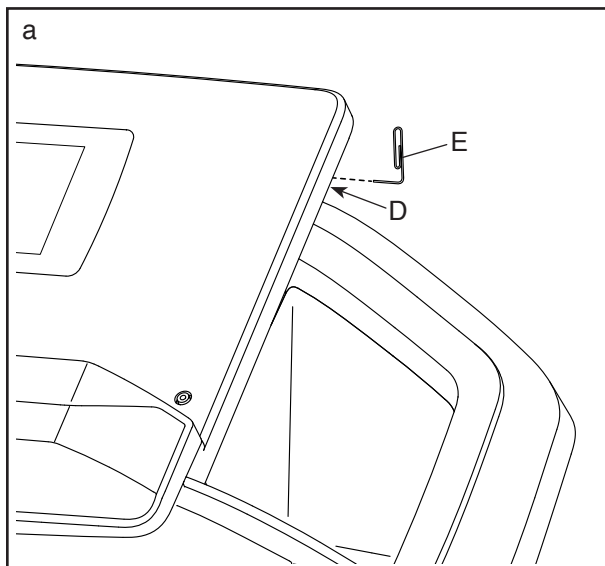

SYMPTOM: The treadmill will not connect to the wireless network

- a. Make sure that the wireless settings on the console are correct (see page 25).
- b. Make sure that the settings for your wireless network are correct.
- c. If you still have questions, go to support.iFit.com.

EXERCISE GUIDELINES

⚠️ WARNING: Before beginning this or any exercise program, consult your physician. This is especially important for persons over age 35 or persons with pre-existing health problems.

These guidelines will help you to plan your exercise program. For detailed exercise information, obtain a reputable book or consult your physician. Remember, proper nutrition and adequate rest are essential for successful results.

EXERCISE INTENSITY

Whether your goal is to burn fat or to strengthen your cardiovascular system, exercising at the proper intensity is the key to achieving results. You can use your heart rate as a guide to find the proper intensity level. The chart below shows recommended heart rates for fat burning and aerobic exercise.

165	155	145	140	130	125	115	♥️
145	138	130	125	118	110	103	♥️
125	120	115	110	105	95	90	♥️
<hr/>							
20	30	40	50	60	70	80	

To find the proper intensity level, find your age at the bottom of the chart (ages are rounded off to the nearest ten years). The three numbers listed above your age define your “training zone.” The lowest number is the heart rate for fat burning, the middle number is the heart rate for maximum fat burning, and the highest number is the heart rate for aerobic exercise.

Burning Fat—To burn fat effectively, you must exercise at a low intensity level for a sustained period of time. During the first few minutes of exercise, your body uses carbohydrate calories for energy. Only after the first few minutes of exercise does your body begin to use stored fat calories for energy. If your goal is to burn fat, adjust the intensity of your exercise until your heart rate is near the lowest number in your training zone. For maximum fat burning, exercise with your heart rate near the middle number in your training zone.

Aerobic Exercise—If your goal is to strengthen your cardiovascular system, you must perform aerobic exercise, which is activity that requires large amounts of oxygen for prolonged periods of time. For aerobic exercise, adjust the intensity of your exercise until your heart rate is near the highest number in your training zone.

HOW TO MEASURE YOUR HEART RATE

To measure your heart rate, exercise for at least four minutes. Then, stop exercising and place two fingers on your wrist as shown. Take a six-second heartbeat count, and multiply the result by 10 to find your heart rate. For example, if your six-second heartbeat count is 14, your heart rate is 140 beats per minute.

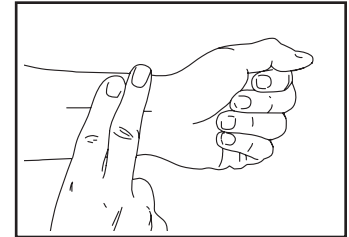

WORKOUT GUIDELINES

Warming Up—Start with 5 to 10 minutes of stretching and light exercise. A warm-up increases your body temperature, heart rate, and circulation in preparation for exercise.

Training Zone Exercise—Exercise for 20 to 30 minutes with your heart rate in your training zone. (During the first few weeks of your exercise program, do not keep your heart rate in your training zone for longer than 20 minutes.) Breathe regularly and deeply as you exercise; never hold your breath.

Cooling Down—Finish with 5 to 10 minutes of stretching. Stretching increases the flexibility of your muscles and helps to prevent post-exercise problems.

EXERCISE FREQUENCY

To maintain or improve your condition, complete three workouts each week, with at least one day of rest between workouts. After a few months of regular exercise, you may complete up to five workouts each week, if desired. Remember, the key to success is to make exercise a regular and enjoyable part of your everyday life.

SUGGESTED STRETCHES

The correct form for several basic stretches is shown at the right. Move slowly as you stretch—never bounce.

1. Toe Touch Stretch

Stand with your knees bent slightly and slowly bend forward from your hips. Allow your back and shoulders to relax as you reach down toward your toes as far as possible. Hold for 15 counts, then relax. Repeat 3 times. Stretches: Hamstrings, back of knees and back.

2. Hamstring Stretch

Sit with one leg extended. Bring the sole of the opposite foot toward you and rest it against the inner thigh of your extended leg. Reach toward your toes as far as possible. Hold for 15 counts, then relax. Repeat 3 times for each leg. Stretches: Hamstrings, lower back and groin.

3. Calf/Achilles Stretch

With one leg in front of the other, reach forward and place your hands against a wall. Keep your back leg straight and your back foot flat on the floor. Bend your front leg, lean forward and move your hips toward the wall. Hold for 15 counts, then relax. Repeat 3 times for each leg. To cause further stretching of the achilles tendons, bend your back leg as well. Stretches: Calves, achilles tendons and ankles.

4. Quadriceps Stretch

With one hand against a wall for balance, reach back and grasp one foot with your other hand. Bring your heel as close to your buttocks as possible. Hold for 15 counts, then relax. Repeat 3 times for each leg. Stretches: Quadriceps and hip muscles.

5. Inner Thigh Stretch

Sit with the soles of your feet together and your knees outward. Pull your feet toward your groin area as far as possible. Hold for 15 counts, then relax. Repeat 3 times. Stretches: Quadriceps and hip muscles.

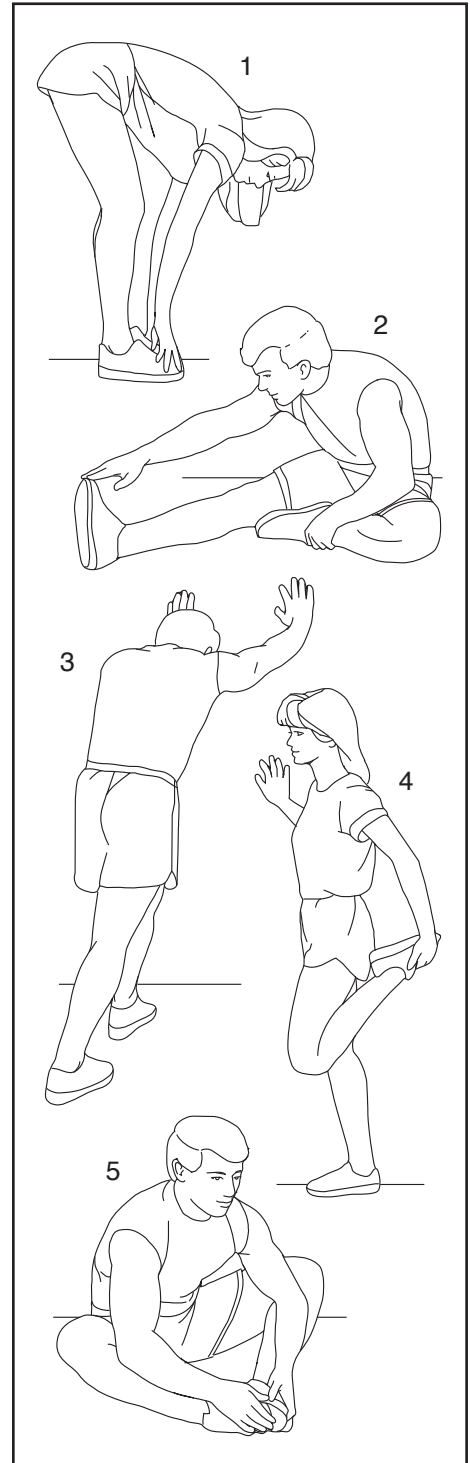

NOTES

PART LIST

Model No. PFTL87720.0 R0121A

Key No.	Qty.	Description	Key No.	Qty.	Description
1	2	3/8" x 1 1/4" Screw	52	2	1/2" Pin
2	2	3/8" x 1 3/4" Screw	53	1	Drive Roller/Pulley
3	4	3/8" x 2 3/8" Screw	54	1	Controller Clamp
4	81	#8 x 3/4" Screw	55	1	Electronics Plate
5	11	#8 x 1/2" Screw	56	4	Cable Tie
6	4	#10 x 3/4" Screw	57	2	Wheel
7	4	5/16" x 2 1/4" Screw	58	1	Drive Motor
8	2	5/16" x 3/4" Screw	59	1	Motor Belt
9	1	#8 x 1/2" Ground Screw	60	1	Frame
10	8	1/4" Star Washer	61	1	Right Rear Foot
11	8	3/8" Star Washer	62	1	Left Rear Foot
12	6	5/16" Star Washer	63	2	Rear Foot
13	2	3/8" x 1 3/8" Bolt	64	1	Idler Roller
14	3	1/4" x 2 1/2" Screw	65	1	Motor Hood
15	2	3/8" x 1 1/8" Bolt	66	1	Motor Hood Cover
16	2	Console Clamp	67	2	Incline Frame Spacer
17	1	Console Ground Wire	68	2	Frame Spacer
18	2	1/4" x 1 1/4" Patch Screw	69	4	3/8" Plastic Bushing
19	4	#8 x 1" Screw	70	1	Incline Motor
20	6	#8 x 5/8" Screw	71	1	Incline Frame
21	1	3/8" x 1 3/4" Bolt	72	2	Incline Motor Spacer
22	1	3/8" x 1 1/2" Bolt	73	1	Controller
23	2	5/16" Drive Motor Screw	74	1	Power Cord
24	4	1/4" x 1/2" Screw	75	1	Power Cord Grommet
25	4	#8 Belt Guide Screws	76	1	Power Switch
26	4	5/16" x 1 3/4" Bolt	77	1	Belly Pan
27	7	#8 x 1/2" Washer Head Screw	78	1	Left Handrail Cover
28	1	5/16" x 1 3/4" Bolt	79	1	Right Handrail Cover
29	1	5/16" x 2 1/4" Bolt	80	1	Left Handrail
30	2	#8 Star Washer	81	1	Right Handrail
31	1	Latch Crossbar	82	1	Left Bottom Handrail Cover
32	4	5/16" Flat Washer	83	1	Right Bottom Handrail Cover
33	2	3/8" Thrust Washer	84	2	9/32" Plastic Bushing
34	6	Small Flat Washer	85	1	Left Upright
35	1	Storage Latch	86	1	Right Upright
36	1	1/4" Nut	87	1	Crossbar
37	5	Hood Clip	88	1	Upright Wire
38	6	3/8" Nut	89	2	Grommet
39	4	5/16" Nut	90	2	Base Pad Spacer
40	1	Console Frame	91	2	Base Pad
41	1	Key/Clip	92	1	Right Base Cover
42	4	Platform Cushion	93	1	Left Base Cover
43	1	Console	94	1	Right Inner Base Cover
44	1	Left Foot Rail	95	1	Left Inner Base Cover
45	1	Right Foot Rail	96	2	Caution Decal
46	1	Warning Decal	97	1	Base
47	1	Walking Platform	98	1	Left Tray
48	2	Console Cable Tie	99	1	Right Tray
49	1	Walking Belt	100	1	Console Base
50	2	Belt Guide	*	-	User's Manual
51	4	Rubber Cushion			

Note: Specifications are subject to change without notice. For information about ordering replacement parts, see the back cover of this manual. *These parts are not illustrated.

EXPLODED DRAWING A

Model No. PFTL87720.0 R0121A

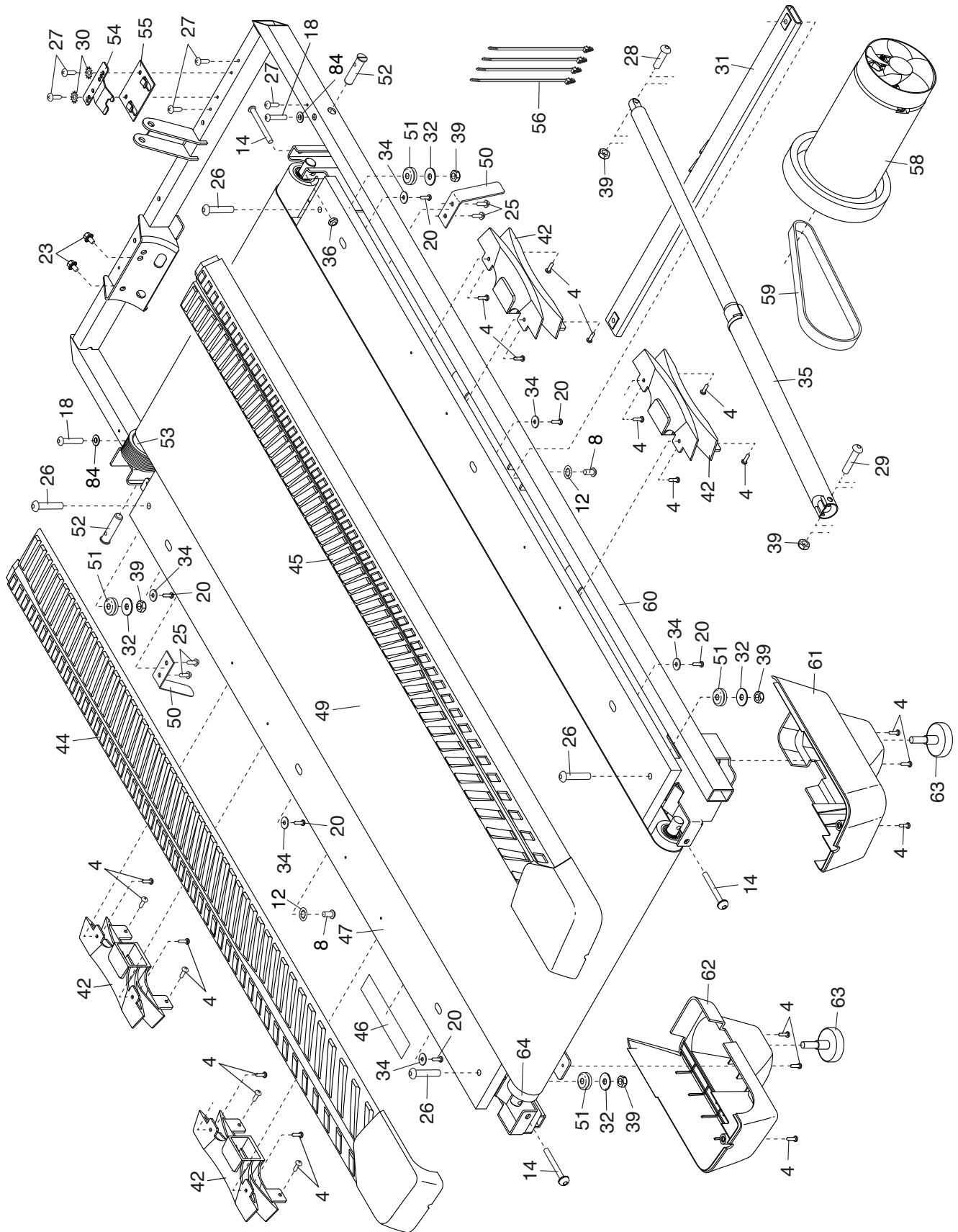

EXPLODED DRAWING B

Model No. PFTL87720.0 R0121A

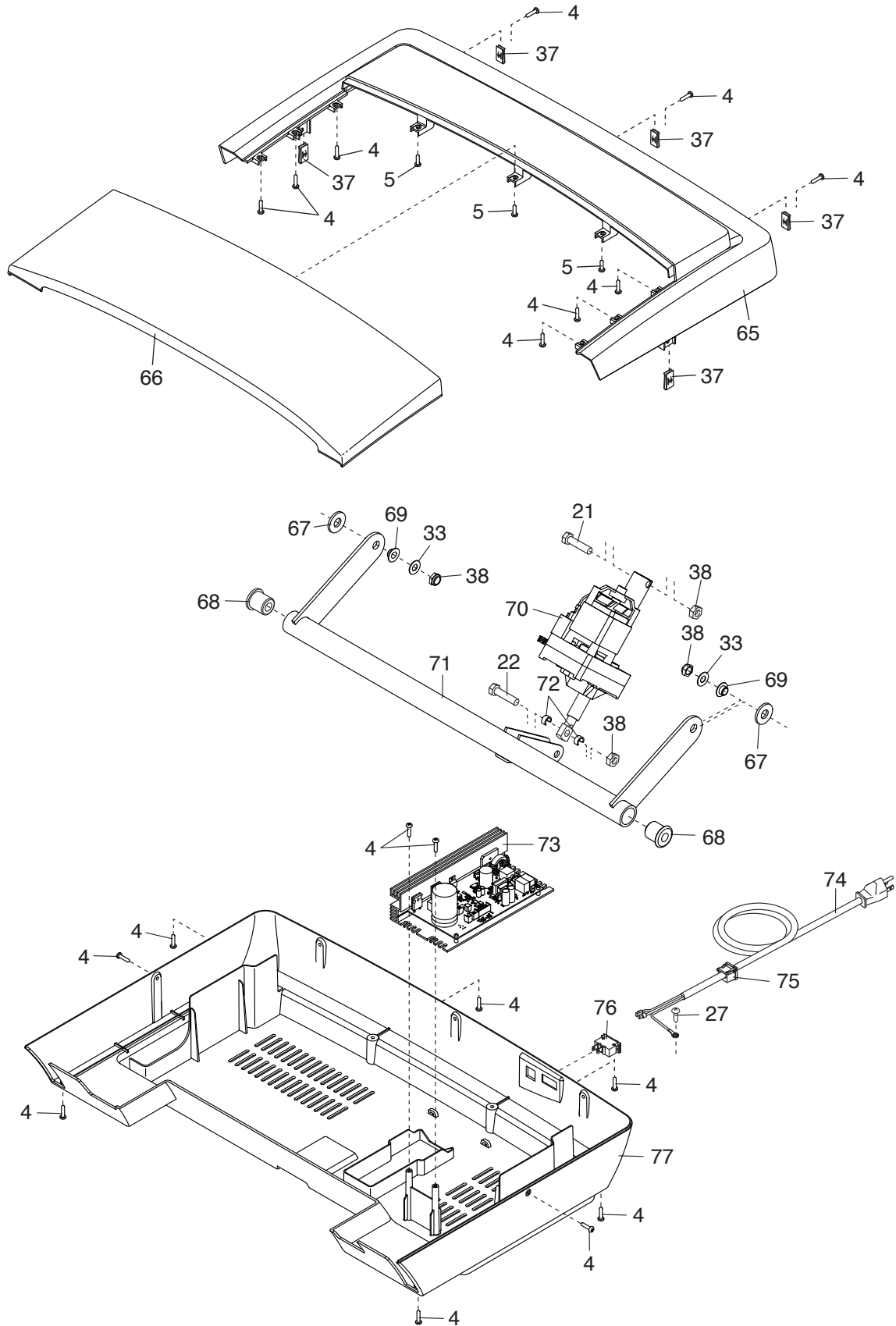

EXPLODED DRAWING C

Model No. PFTL87720.0 R0121A

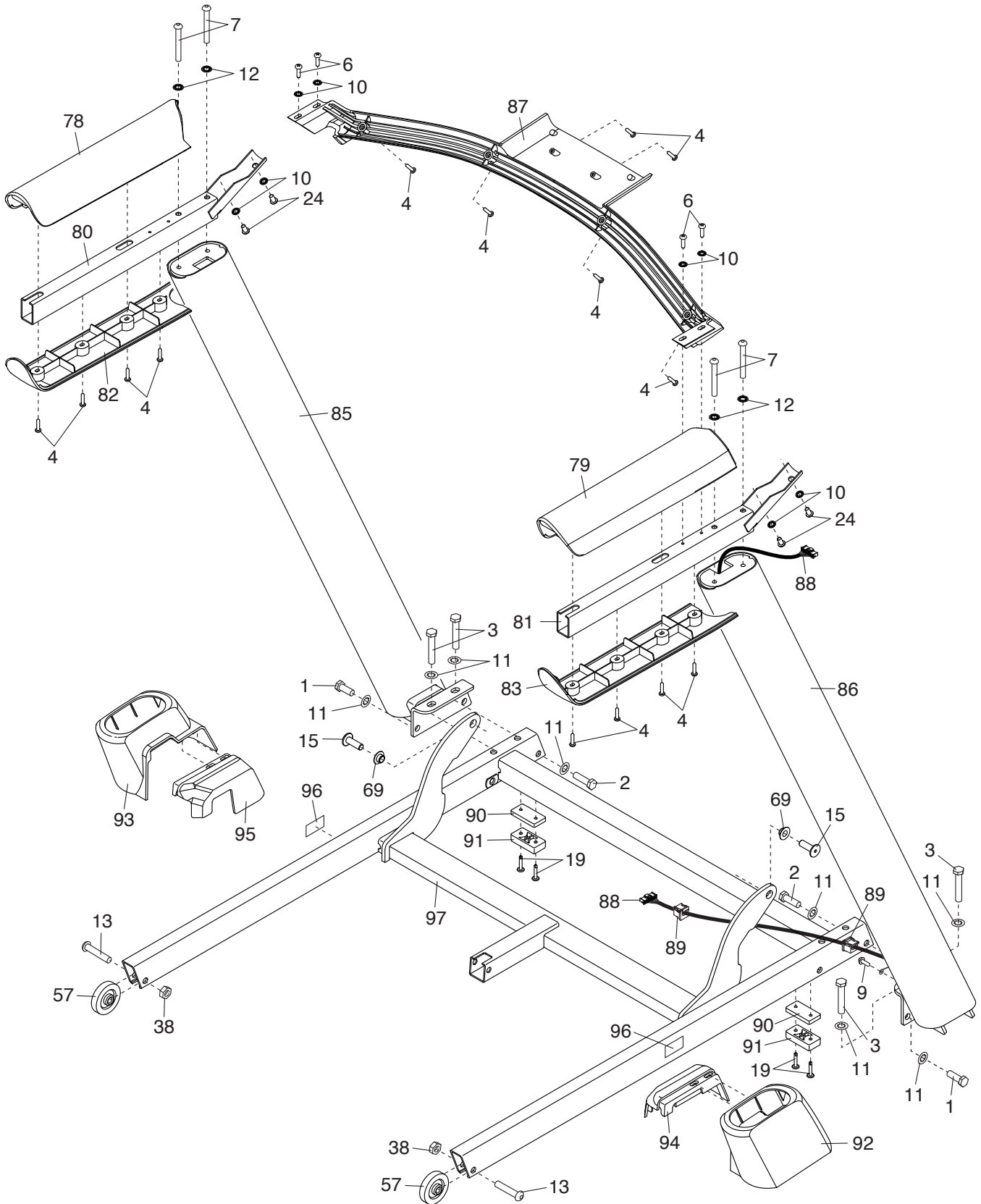

EXPLODED DRAWING D

Model No. PFTL87720.0 R0121A

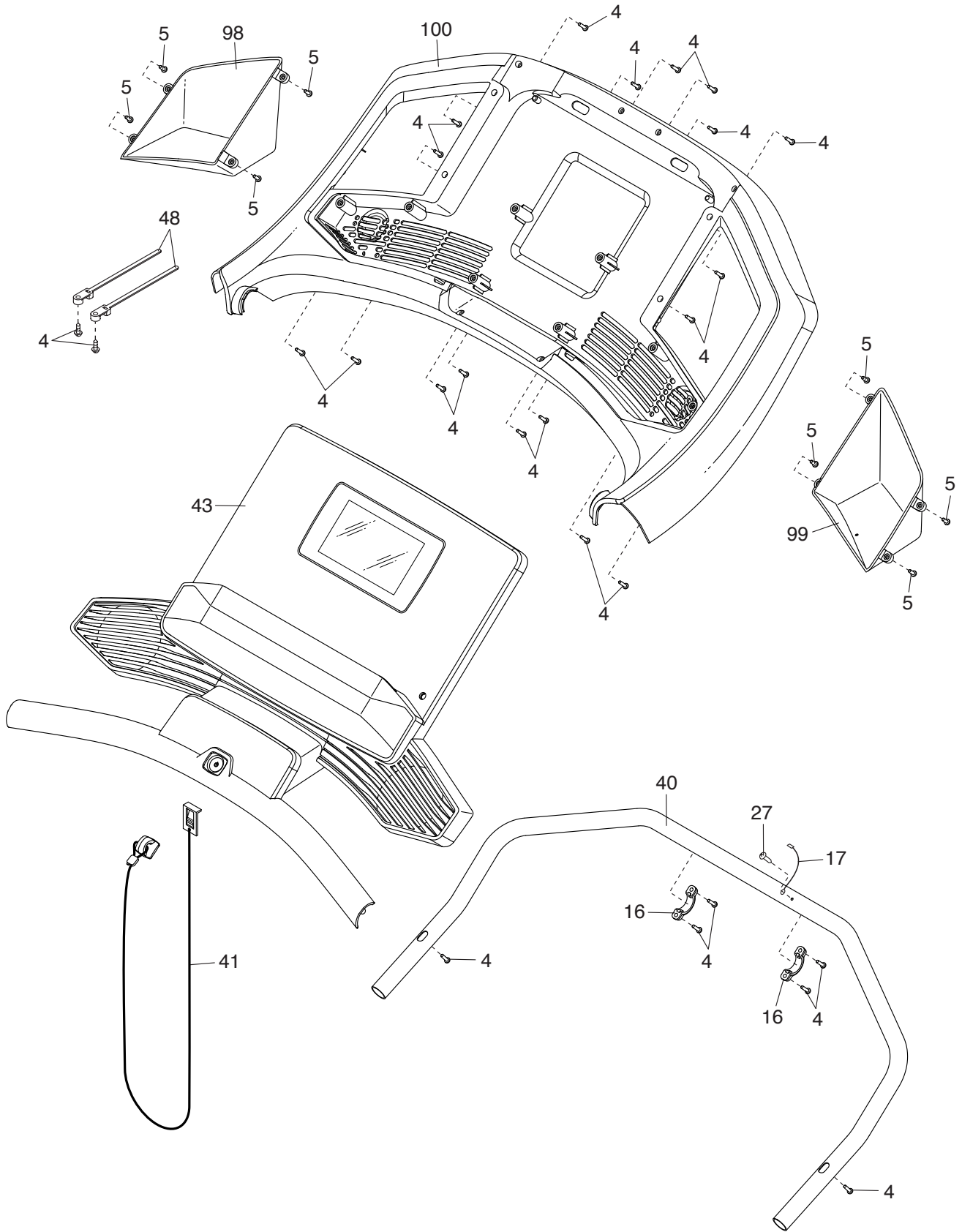

ORDERING REPLACEMENT PARTS

To order replacement parts, please see the front cover of this manual. To help us assist you, be prepared to provide the following information when contacting us:

- the model number and serial number of the product (see the front cover of this manual)
- the name of the product (see the front cover of this manual)
- the key number and description of the replacement part(s) (see the PART LIST and the EXPLODED DRAWING near the end of this manual)

LIMITED WARRANTY

IMPORTANT: To protect your fitness equipment with an extended service plan, see page 5.

ICON Health & Fitness, Inc. (ICON) warrants this product to be free from defects in workmanship and material, under normal use and service conditions. The frame is warranted for ten (10) years from the date of purchase. Parts and labor are warranted for one (1) year from the date of purchase.

This warranty extends only to the original purchaser (customer) and is not transferrable. ICON's obligation under this warranty is limited to repairing or replacing, at ICON's option, the product through one of its authorized service providers. All repairs for which warranty claims are made must be preauthorized by ICON. If replacement parts are shipped while the product is under warranty, the customer will be responsible for a minimal handling charge. For in-home service, the customer may be responsible for a minimal trip charge. This warranty does not extend to freight damage to the product. This warranty will automatically be voided by the following conditions: (1) if the product is used as a store display model, (2) if the product is purchased or transported outside the USA, (3) if all instructions and warnings in this manual are not followed, (4) if the product is abused or improperly or abnormally used, or (5) if the product is used for commercial or rental purposes. No other warranty beyond that specifically set forth above is authorized by ICON.

ICON is not responsible or liable for the following damages: (1) indirect, special, or consequential damages arising out of or in connection with the use or performance of the product; (2) damages with respect to any economic loss, loss of property, loss of revenues or profits, loss of enjoyment or use, or costs of removal or installation; or (3) other consequential damages of any kind. Some states do not allow the exclusion or limitation of incidental or consequential damages. Accordingly, the above limitation may not apply to the customer.

The warranty extended hereunder is in lieu of any and all other warranties, and any implied warranties of merchantability or fitness for a particular purpose are limited in their scope and duration to the terms set forth herein. Some states do not allow limitations on how long an implied warranty lasts. Accordingly, the above limitation may not apply to the customer. This warranty provides specific legal rights; the customer may have other rights that vary from state to state.

For warranty service, please call the telephone number on the front cover of this manual. Please be prepared to provide the model number and serial number of the product (see the front cover of this manual).

ICON Health & Fitness, Inc., 1500 S. 1000 W., Logan, UT 84321-9813