



GAME WINNER®

Assembly Instructions

30 Gal Molded Barrel Feeder

Style #158212

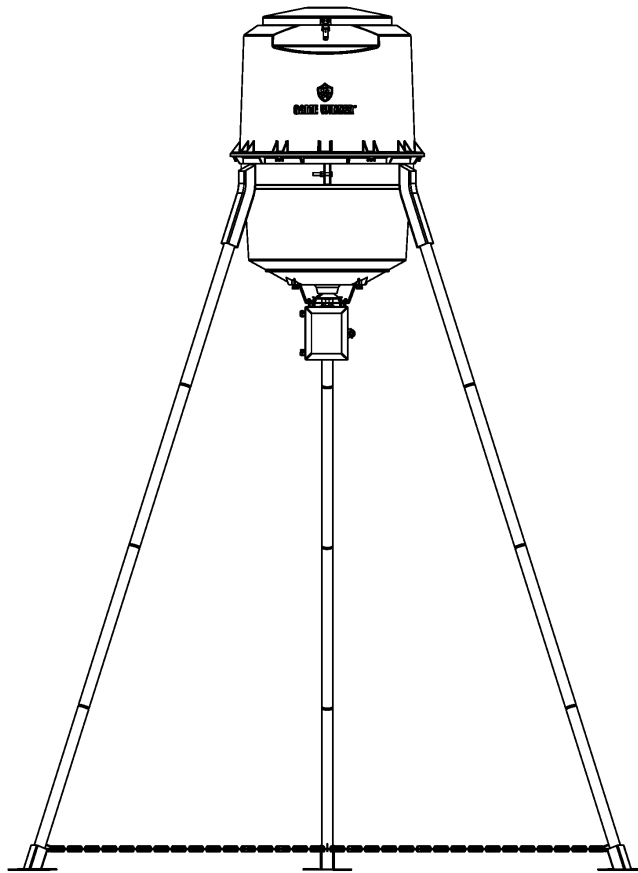

Please keep this instruction manual for future reference

Customer Service: (888) 922-2336, 7:00am to 12:00am CST daily

Live Chat at: www.academy.com

Email: customerservice@academy.com

(Made in China)

Table of Contents	Page
--------------------------	-------------

Warnings -----	3-5
Tools required -----	6
Parts List -----	7
Hardware List -----	8
Parts List / Hardware – Timer Kit Set -----	9
Solar Panel Ready Kit-----	9
Assembly Instructions -----	10-14
How to load your feeder -----	15
How to install the battery /	
How to operate the timer -----	16
Care and Maintenance -----	16
Warranty -----	17

NOTE: Before beginning assembly of product, make sure all parts are present. Compare parts with package content list and hardware contents. If any part is missing or damaged do not attempt to assemble the unit. Contact customer service for replacement parts.

Warnings

YOUR GAME WINNER 30 GAL MOLDED BARREL FEEDER IS DESIGNED, ENGINEERED AND CONSTRUCTED IN A MANNER THAT MAKES IT A RUGGED AND PORTABLE PIECE OF HUNTING EQUIPMENT. YOU SHOULD NEVER ATTEMPT TO ASSEMBLE THIS FEEDER ALONE. YOU MUST HAVE A MINIMUM OF TWO (2) ADULTS FOR THE SAFE ERECTION OF YOUR FEEDER. FAILURE TO FOLLOW THESE INSTRUCTIONS MAY RESULT IN SERIOUS INJURY OR DEATH! THIS FEEDER MUST BE ERECTED ONLY ON A FIRM AND LEVEL GROUND. PRIOR TO FILL THE HOPPER, **RECOMMENDED INSTALL THREE (3) STAKES (NOT INCLUDED)**. FAILURE TO FOLLOW THESE INSTRUCTIONS MAY RESULT IN SERIOUS INJURY OR DEATH!

REFER TO THE IMAGES IN THIS MANUAL FOR VISUALIZATION OF THE ASSEMBLY PROCESS IN ADDITION TO READING THE INSTRUCTIONS. SOME PARTS CONTAIN SHARP EDGES. SHARP POINTS OR EDGES CAN SCRATCH, POKE, OR PUNCTURE. WEAR APPROPRIATE CLOTHING AND SAFETY GLOVES DURING ASSEMBLY.

PRIOR TO ATTEMPTING TO USE THIS UNIT, TAKE A MOMENT TO BECOME FAMILIAR WITH THE ASSEMBLY, SETUP AND INSTALLATION. FAILURE TO FOLLOW THESE INSTRUCTIONS MAY RESULT IN SERIOUS INJURY OR DEATH!

DO NOT USE THIS UNIT AROUND POWER GENERATING EQUIPMENT (TRANSFORMERS, GENERATORS, SUBSTATIONS, ETC) AND/OR TRANSMISSION EQUIPMENT (POWER LINES). FAILURE TO FOLLOW THESE INSTRUCTIONS MAY RESULT IN SERIOUS INJURY OR DEATH!
DO NOT LOAD FEED WITHOUT ANOTHER ADULT. FAILURE TO FOLLOW THESE INSTRUCTIONS MAY RESULT IN SERIOUS INJURY OR DEATH!
DO NOT CLIMB ON AND/OR LOAD FEEDER UNDER AND/OR DURING BAD WEATHER SUCH AS STORMS, SNOW, LIGHTNING OR THUNDERSTORM. FAILURE TO FOLLOW THESE INSTRUCTIONS MAY RESULTS IN SERIOUS INJURY OR DEATH!

DO NOT SIT OR STAND ON OR INSIDE THE HOPPER. FAILURE TO FOLLOW THESE INSTRUCTIONS MAY RESULT IN SERIOUS INJURY OR DEATH!
DO NOT LOAD OVER **200** POUNDS OF FEED. FAILURE TO FOLLOW THESE INSTRUCTIONS MAY RESULT IN SERIOUS DAMAGE TO THIS UNIT.
DO NOT LOAD FEEDER UNTIL IT IS COMPLETELY ASSEMBLED AND STANDING UP IN PLACE.

DO NOT STORE OR HANG ITEMS ON THE HOPPER. FAILURE TO FOLLOW THESE INSTRUCTIONS MAY RESULT IN SERIOUS DAMAGE TO THIS UNIT.
DO NOT DISASSEMBLE AND/OR REMOVE PARTS WITHOUT ANOTHER ADULT PRESENT. FAILURE TO FOLLOW THESE INSTRUCTIONS MAY RESULT IN SERIOUS INJURY OR DEATH!

DO NOT ASSEMBLE, DISASSEMBLE AND/OR REMOVE PARTS FROM THE FEEDER UNDER AND/OR DURING BAD WEATHER SUCH AS STORM, SNOW, LIGHTNING OR THUNDERSTORM. FAILURE TO FOLLOW THESE INSTRUCTIONS MAY RESULT IN SERIOUS INJURY OR DEATH!

Warnings

DO NOT ATTEMPT TO FILL A FULL LOAD OF FEED AT ONE TIME. LOAD ONE BAG AT A TIME UNTIL HOPPER IS FULL. FAILURE TO FOLLOW THESE INSTRUCTIONS MAY RESULT IN SERIOUS INJURY OR DEATH.

DO NOT CLIMB THE FEEDER. FAILURE TO FOLLOW THESE INSTRUCTIONS MAY RESULT IN SERIOUS INJURY OR DEATH!

THE 6 V RECHARGEABLE BATTERY (NOT INCLUDED) SHOULD HAVE A COMPLETE CHARGE PRIOR TO THE FIRST TIME OF OPERATION. THIS REQUIRES A MINIMUM OF AT LEAST SIX (6) HOURS OF CHARGING.

TO TEST YOUR FEEDER FOLLOW THE INSTRUCTIONS IN THE TIMER MANUAL. DO NOT TEST FEEDER WHEN IT CONTAINS FEED. TEST FEEDER WHEN EMPTY ONLY! TESTING THE FEEDER WHILE IT CONTAINS FEED WILL CAUSE FEED TO BE DISCHARGED AT A HIGH VELOCITY AND COULD RESULT IN BODY INJURY. FAILURE TO FOLLOW THESE INSTRUCTIONS MAY RESULT IN SERIOUS INJURY OR DEATH!

OPERATION IS SUBJECT TO THE FOLLOWING TWO CONDITIONS:

- THIS DEVICE MAY NOT CAUSE HARMFUL INTERFERENCE.
- THE DEVICE MUST ACCEPT ANY INTERFERENCE RECEIVED, INCLUDING INTERFERENCE THAT MAY CAUSE UNDESIRED OPERATION.

THOROUGHLY INSPECT THE FEEDER PRIOR TO EACH USE FOR SIGNS OF WEAR, ROT, CORROSION, CRACKS, DETERIORATION AND/OR ANY OTHER TYPE OF DEFECT. DO NOT USE THIS FEEDER IF IT SHOWS EVIDENCE OF WEAR, ROT, CORROSION, CRACKS, DETERIORATION AND/OR ANY OTHER TYPE OF DEFECT. FAILURE TO FOLLOW THESE INSTRUCTIONS MAY RESULT IN SERIOUS INJURY OR DEATH. DO NOT REMOVE, MODIFY AND/OR OMIT ANY PART OR OTHERWISE MECHANICALLY MODIFY THIS UNIT OR ITS ASSEMBLY IN ANY MANNER. MODIFICATION, OMISSION AND/OR PART SUBSTITUTION MAY RESULT IN SERIOUS INJURY OR DEATH!

BEFORE STANDING UP THE FEEDER, YOU MUST CHECK ALL HARDWARE TO BE SURE IT IS IN PLACE AND TIGHT.

CHECK ALL BOLTS AND NUTS TO BE SURE THEY ARE FIRM AND TIGHT.

DO NOT THROW AWAY THE PACKAGING MATERIAL AT THIS TIME.

Warnings



! IMPORTANT !

THE MANUFACTURER OF 30 GAL MOLDED BARREL FEEDER IS NOT RESPONSIBLE FOR ANY INACCURATE INFORMATION YOU HAVE RECEIVED REGARDING STATE FEEDING REGULATIONS. PLEASE ALWAYS KEEP YOUR INFORMATION UP-TO-DATE AND RELIABLE. MANY STATE LAWS CHANGE AND ARE AMENDED WITHOUT NOTICE. ALWAYS DOUBLE CHECK YOUR STATE AND SPECIFIC COUNTY FEEDING LAWS REGARDING THE USE OF FEEDERS.

Tools Required

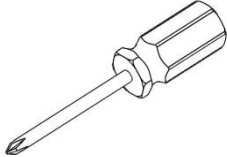

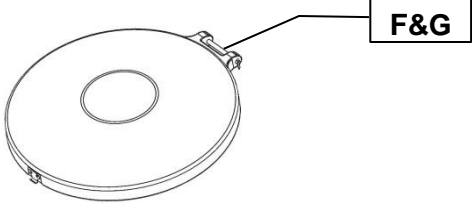
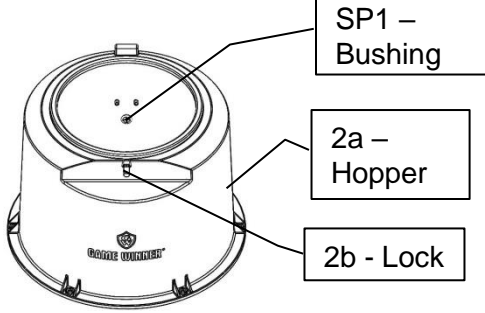
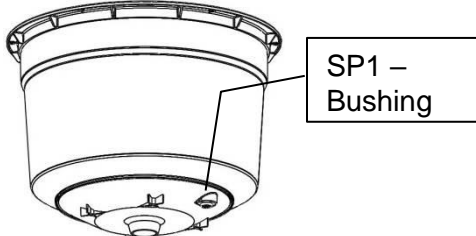
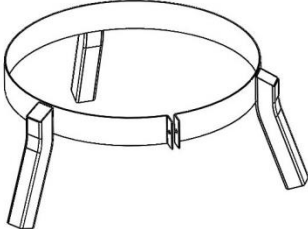
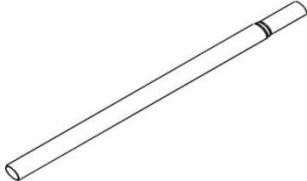
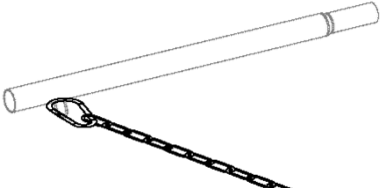
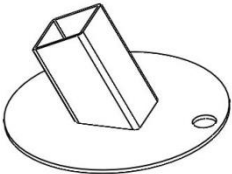

1	Hex Nut Wrench	2 pcs	
2	Phillips Head Screwdriver	1 pcs	

Parts List

1	Lid		1 pc
2	Top Hopper		1 pc
3	Bottom Hopper		1 pc
4	Metal Ring		1 pcs
5	Support Leg		9 pcs
6	Support Leg with Chain		3 pcs
7	Foot		3 pcs

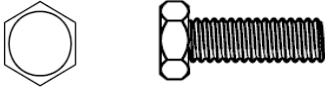
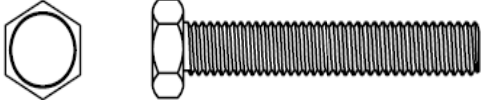

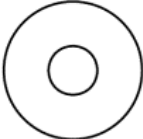
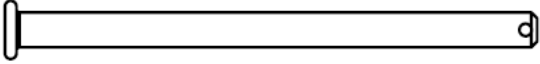
Hardware list

Hardware for assembly of feeder

A	Hex. Bolt (M6x25)		12 pcs
B	Hex. Bolt (M8x50)		1 pcs
C	Wing Nut (M6)		12 pcs
D	Locking Nut (M8)		1 pcs
E	Flat Washer (dia. 8mm)		1 pcs
F	Hinge Pin (6×90)		1 pcs
G	Cotter Pin(2×20)		1 pcs

Parts List - Timer Kit Set

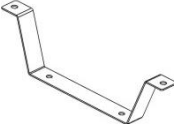
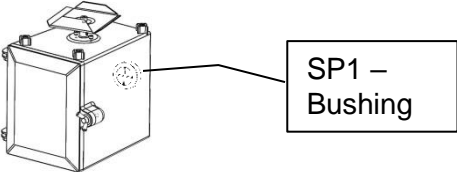
!! Component and Hardware are packed INSIDE the Timer Kit Set package!!

8	Mounting Bracket		2 pc
9	Timer Kit		1 pcs
10	Digital Timer		1 pc

Hardware List - Timer Kit Set

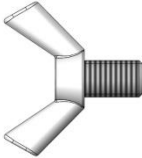
H	Wing Bolt (M5x8)		8 pcs
---	------------------	---	-------

Solar Panel Ready Kit

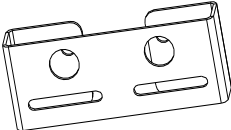
11	Universal Solar Panel Fixture		1 pc
----	-------------------------------	---	------

Product Diagram

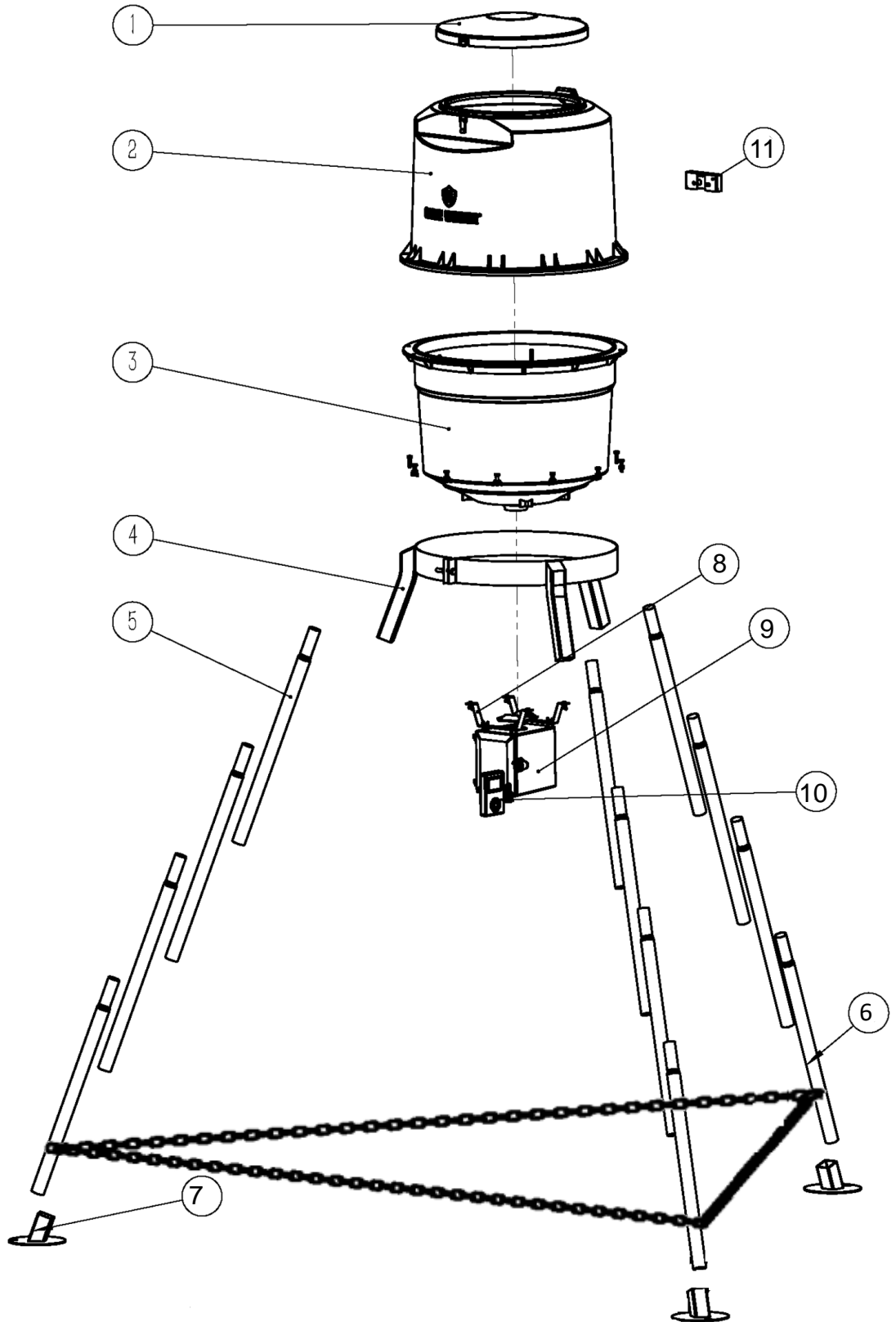

Assembly Instructions

Step 1:

Insert Hinge Pin(#F) into Hinge components of Lid (#1) and Top Hopper(#2)

Secure with Cotter Pin (#G) and bend the ends over.

Hardware:

#G - 1 pc

#F- 1 pc

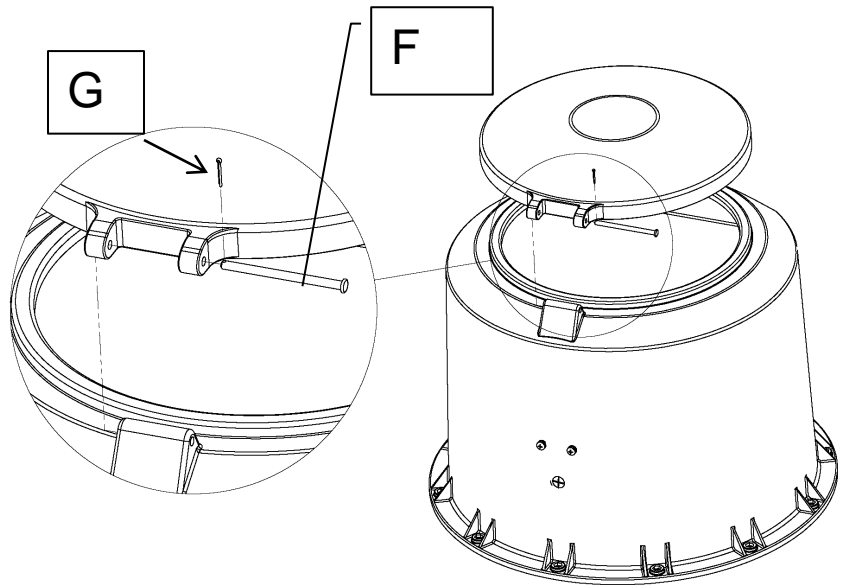

Step 2:

Install the Top Hopper(#2) and the Bottom Hopper(#3) together using bolts (#A, M6x25) and wing nuts (#C, M6)

Tighten bolts.

Be sure to align Bushing SP1 on Top Hopper(#2) with Bushing SP1 on Bottom Hopper(#3)

Hardware:

#A - 12 pcs

#C - 12 pcs

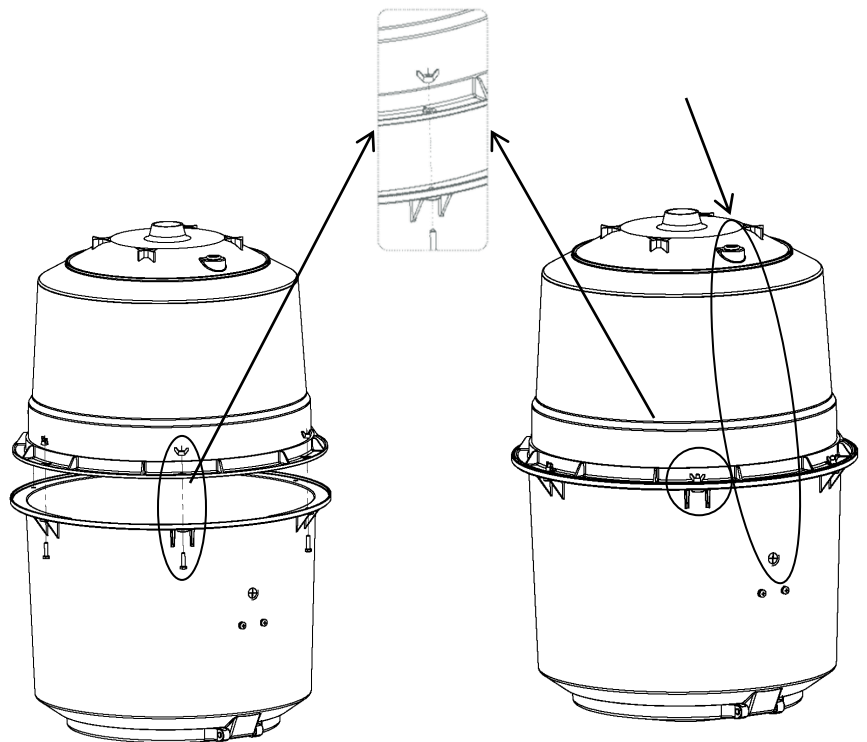

Assembly Instructions

Step 3:

Secure the Metal Ring(#4) to the bottom barrel(#3) with #B, #D, #E (use Hex Nut Wrench 2 pcs)

Note: Tighten until snug. Do not over tighten.

Be sure to align Bushing SP1 on Top Hopper(#2) with Bushing SP1 on Bottom Hopper(#3) and Timer Kit(#8).

Hardware:
#B - 1 pcs
#D - 1 pcs
#E - 1 pcs

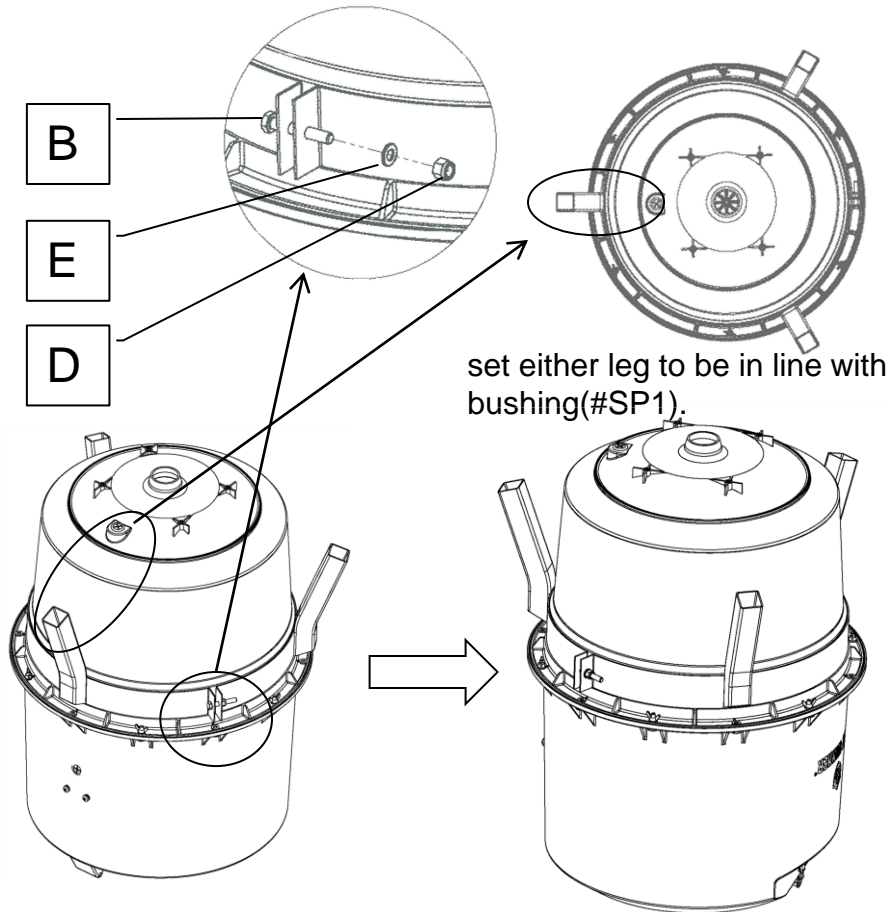

Step 4:

Assembly of the Timer Kit. Attach the Mounting Bracket(#7) to the Timer Kit(#8) Using #H

Hardware:
#H - 4 pcs

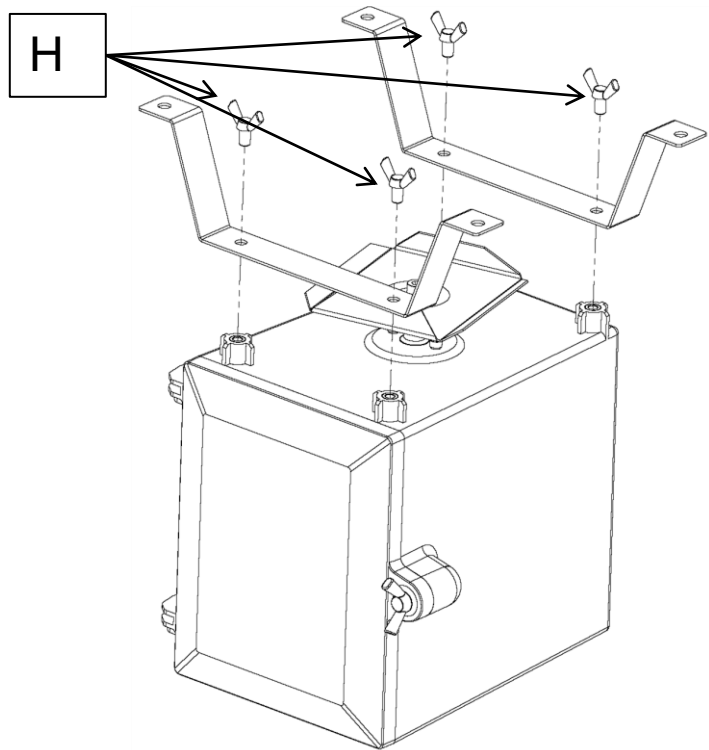

Assembly Instructions

Step 5:

Assemble the Timer Kit(#7 & 8) on the Bottom Hopper (#3). Using #H, Be sure to align Bushing SP1 on timer kit with bushing SP1 on bottom hopper(#3)

Hardware:
#H - 4 pcs

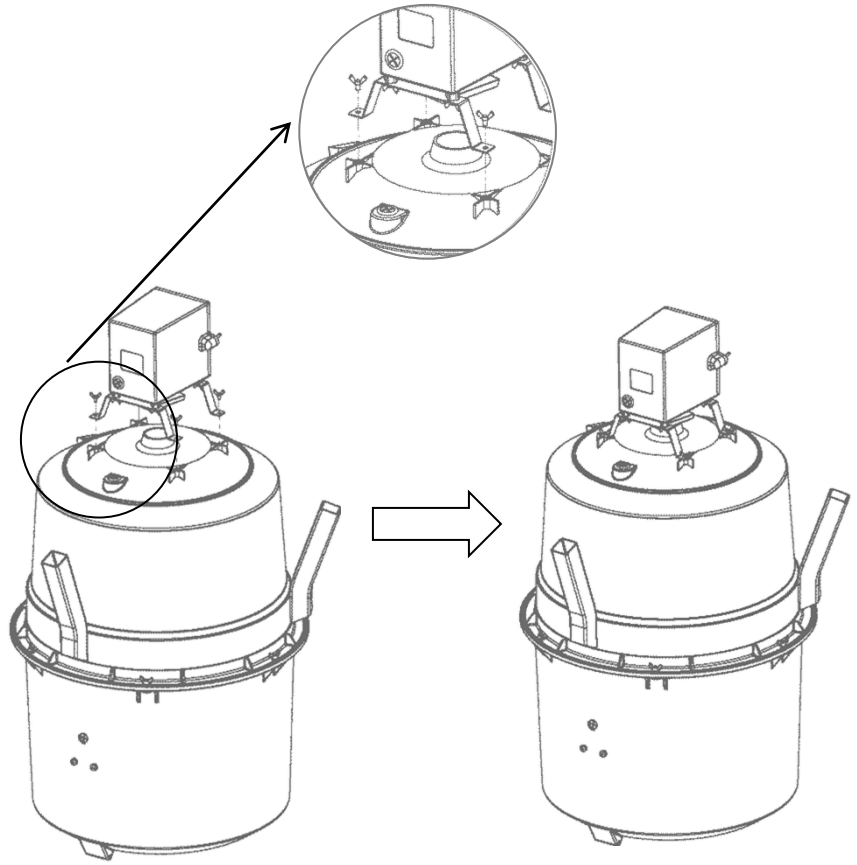

Step 6:

Attach support legs #5 and support legs with chains #6 together and insert into square tubing on metal ring. Slide the male end of one leg section into the female end of another leg section. When fully seated, twist the leg section approximately 1/4 turn until snug.

Note, there should be three support legs #5 and one support leg with chains #6 per leg.

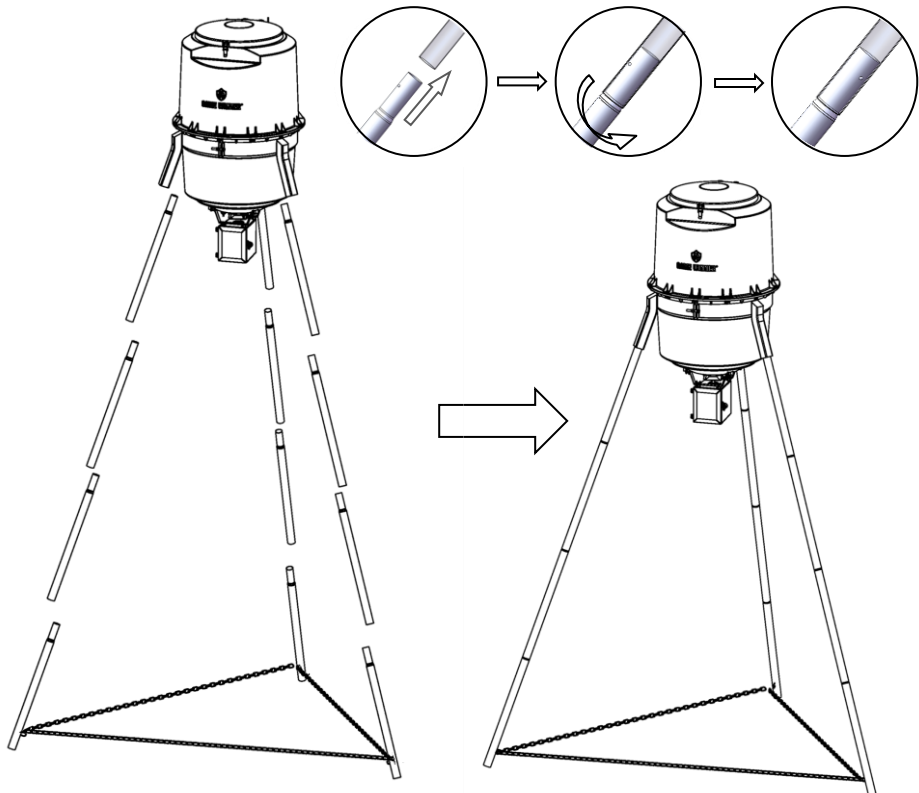

Assembly Instructions

Step 7:

Insert the Feet(#7) onto Support Legs(#6).

WARNING:

CHAINS SHOULD BE TIGHT AFTER ASSEMBLY. IF CHAINS ARE TIGHT THEN YOUR FEEDER IS ASSEMBLED CORRECTLY AND SAFELY.

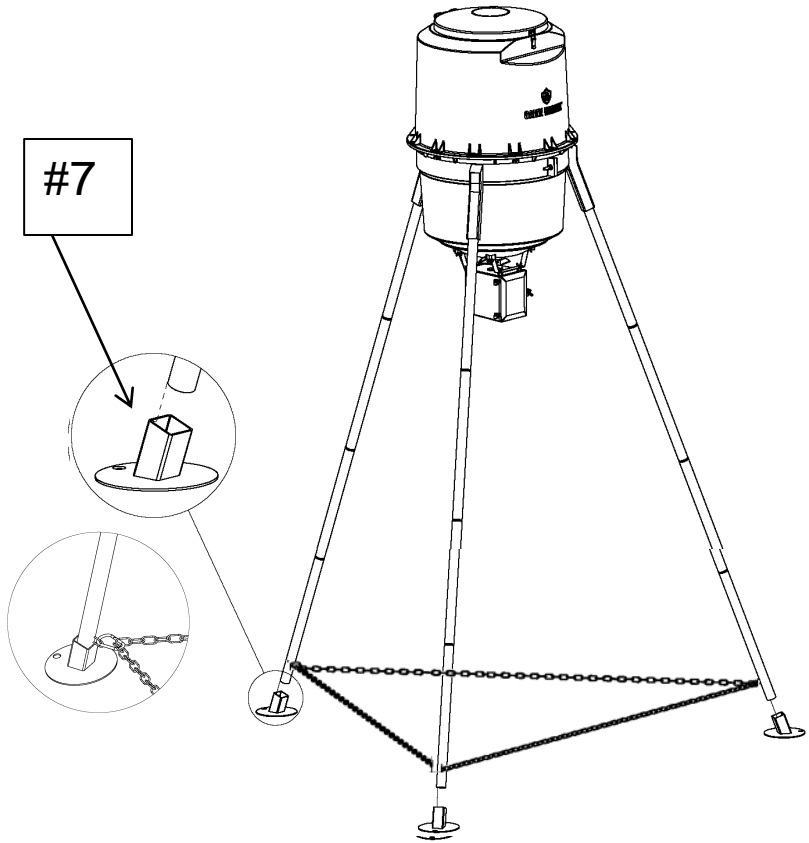

WARNING

Assembly is completed. Use stakes (not included) to secure your feeder to the ground.

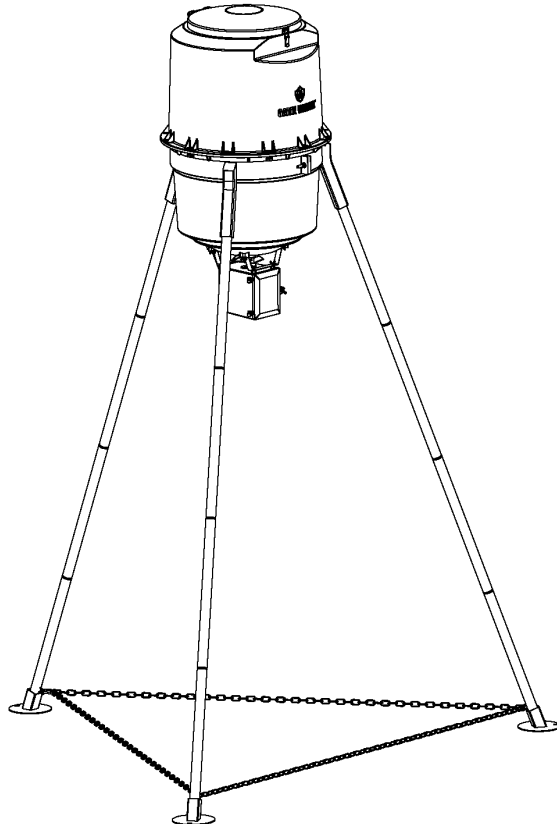

HOW TO LOAD YOUR FEEDER

OPEN THE LID AND POUR FEED INTO THE HOPPER. ONE BAG AT A TIME. DO NOT USE A LEAN-TO OR EXTENSION STYLE LADDER TO AID IN FILLING THE HOPPER. THIS COULD CAUSE THE FEEDER TO TIP OVER AND CAUSE INJURY. IF ADDITIONAL HEIGHT IS NEEDED FOR FILLING, USE A SIMPLE A-FAME STEP PLATFORM LADDER. AFTER FILLING, CLOSE AND LOCK THE LID.

TIPS & POINTERS:

(Q) What kind of feed should I use?

(A) Whole kernel corn is recommended. Whole kernel corn mixed with soybeans or pellets is also effective for attracting deer. NOTE: When not mixed with corn, some types of pellets can take on moisture and clog the feeder.

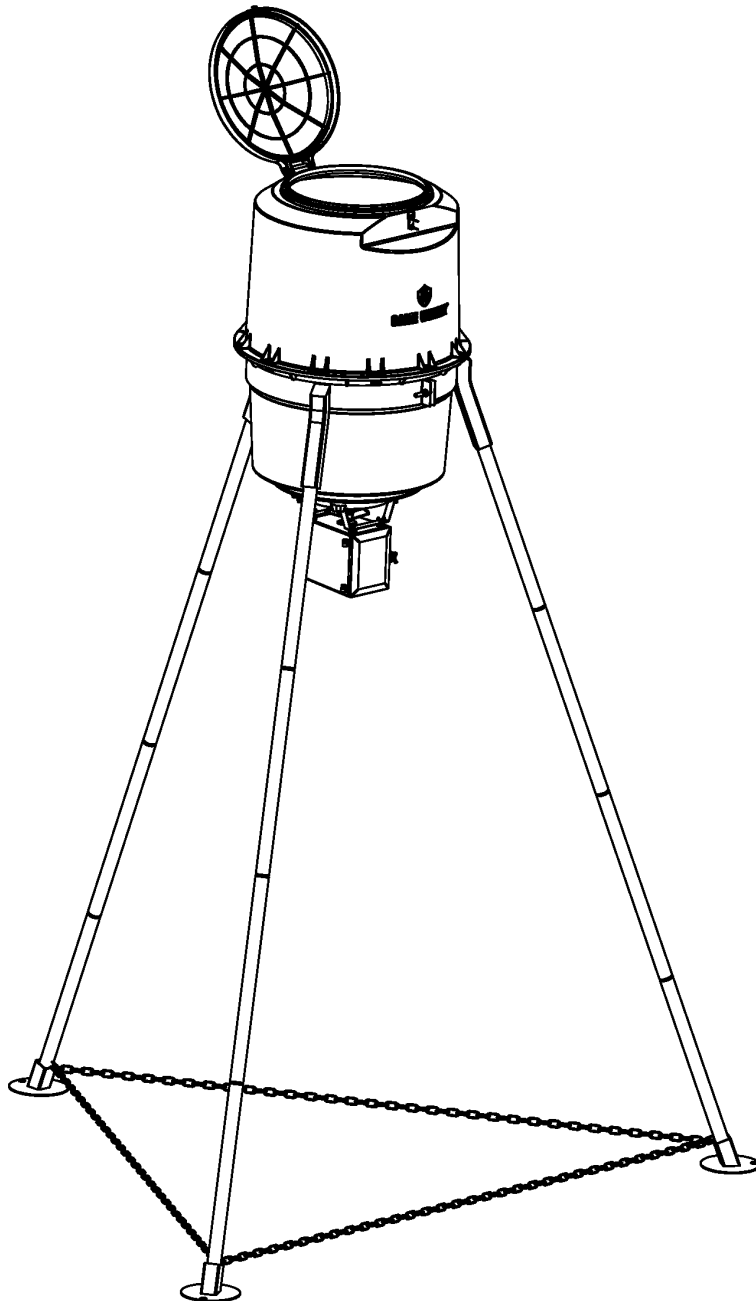

HOW TO INSTALL BATTERY



REMOVE TIMER KIT COVER AND INSTALL A 6 V RECHARGEABLE BATTERY (NOT INCLUDED) BY ATTACHING RED ALLIGATOR CLIP TO THE POSITIVE TERMINAL (+) AND BLACK ALLIGATOR CLIP TO THE NEGATIVE (-) TERMINAL.

HOW TO OPERATE THE TIMER

HOW TO OPERATE THE TIMER

READ THE OPERATION MANUAL INCLUDED IN THE TIMER KIT UNIT.

If a problem still exists, please contact customer service for help

CARE AND MAINTENANCE

EXAMPLE OF CARE AND MAINTENANCE

- INSPECT FEEDER FOR ANY LOOSE PARTS OR HARDWARE
- CLEAN FEEDER HOPPER REGULARLY TO AVOID CLOGGING AND DAMAGE TO THE CONTROL UNIT



ATTENTION



IF USING THE GAME WINNER TIMER AS A REPLACEMENT TIMER, IT WILL WORK WITH EITHER 6 OR 12 VOLT MOTORS.

***** GAME WINNER MOTORS ARE 6 VOLT. *****

Warranty Information

1. Manufacturer warrants this Product to be free from defects in workmanship and materials for a period of 90 days from the date of purchase, PROVIDED claims are submitted, in writing, with proof of purchase.
2. If any part of this item fails because of a manufacturing defect within the Limited Warranty Period, Manufacturer offers to replace such part(s) provide that such parts have not been improperly repaired, altered, or tampered with or subject to misuse, abuse or exposed to corrosive conditions. This Limited Warranty is, however, subject to certain limitations, exclusions, time limits and exceptions (Hereinafter "Conditions") as listed below. Read these Conditions carefully.
3. This Limited Warranty shall be limited to the replacement or repair of any part(s) which Manufacturer determines, after reasonable examination, to have been defective at the time of manufacturing and manufacturer's obligation(s) shall be limited to replacement, if any, of defective part(s) which shall be shipped at Original Purchaser's expense to Original Purchaser's designated shipping address.
4. This Limited Warranty is given to and covers the **ORIGINAL PURCHASER ONLY** and such coverage terminates 90 days from the date of purchase.
5. **DAMAGE LIMITATION WARNING:** IN NO EVENT SHALL MANUFACTURER BE LIABLE FOR ANY INCIDENTAL OR CONSEQUENTIAL DAMAGES, INCLUDING (BUT NOT LIMITED TO) LOSS OF USE OF THE PRODUCT, LOSS OF TIME, INCONVENIENCE, EXPENSES FOR TRAVEL, TRANSPORTATION, LODGING EXPENSES, LOSS OF FOOD, LOSS BY DAMAGE TO PERSONAL PROPERTY OR LOSS OF INCOME, PROFITS OR REVENUE.
6. **MANUFACTURER'S OBLIGATION:** Manufacturer's liability shall be limited to the delivery of a good, merchantable Product and, if necessary, the repair or replacement, at manufacturer's option, of any defective part or unit.
7. **TRANSFER LIMITATIONS:** This Limited Warranty is not assignable or transferable. It covers only the original purchaser.
8. **RESERVED RIGHT TO CHANGE:** Manufacturer reserves the right to make changes or improvements to products it produces in the future without imposing on itself any obligations to install the same improvements in the products it has previously manufactured.
9. This Limited Warranty gives the Original Purchaser specific legal rights but there may be other rights which vary by jurisdiction.
10. **This warranty does not cover the following items:**
 - Chips or scratches on porcelain or painted surfaces
 - Rust or corrosion is not deemed a manufacturing or materials defect
 - Discoloration or loss of paint due to handling during assembly, heat or cleaning products. Paint may require touch up.
 - Stainless steel discoloration or corrosion
 - Consumables such as batteries
 - Damages caused by wild game