



ASSEMBLY INSTRUCTIONS FOR 2B1505 & 2P1504 KWIK FLEX® LITE GOALS

1. Unpack all parts and check for damage that may have occurred during shipping. If damage has occurred, notify Kwik Goal immediately. Lay out all parts. Remove all cardboard and packaging immediately. Wet or damp packaging may damage contents.

Parts

Goal Frame & Net (1)

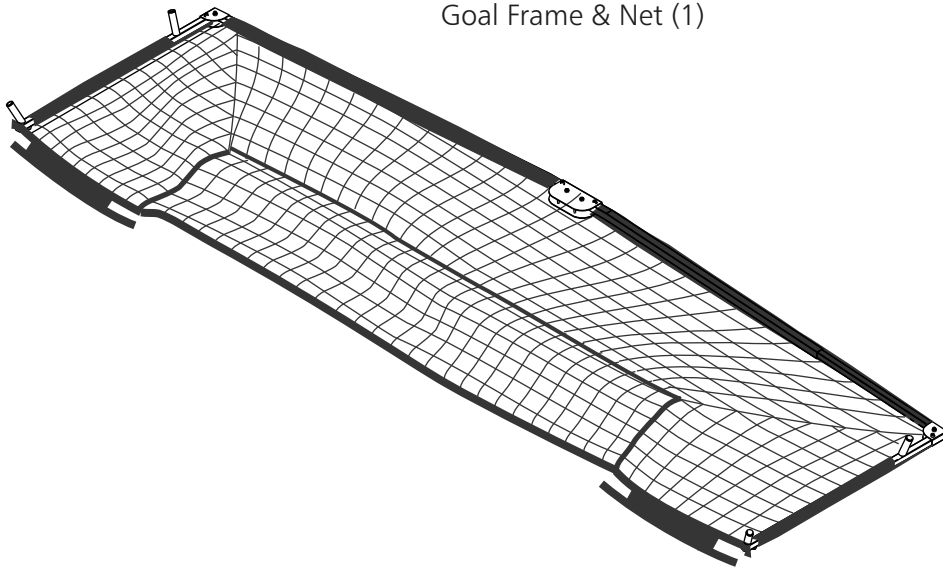

Carry Bag (1)

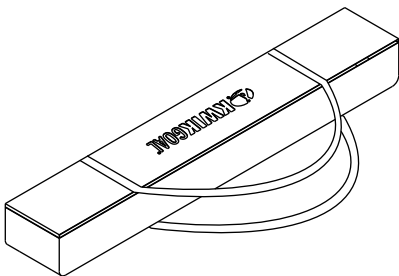

Tension Rod (4)

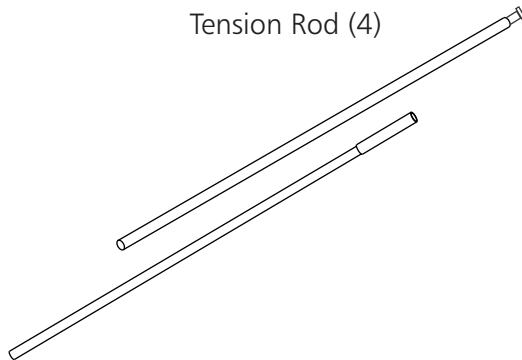

2. Open base frame by swinging outward until button locks in place in center connector as shown. Use care to keep net from getting pinched in moving parts.

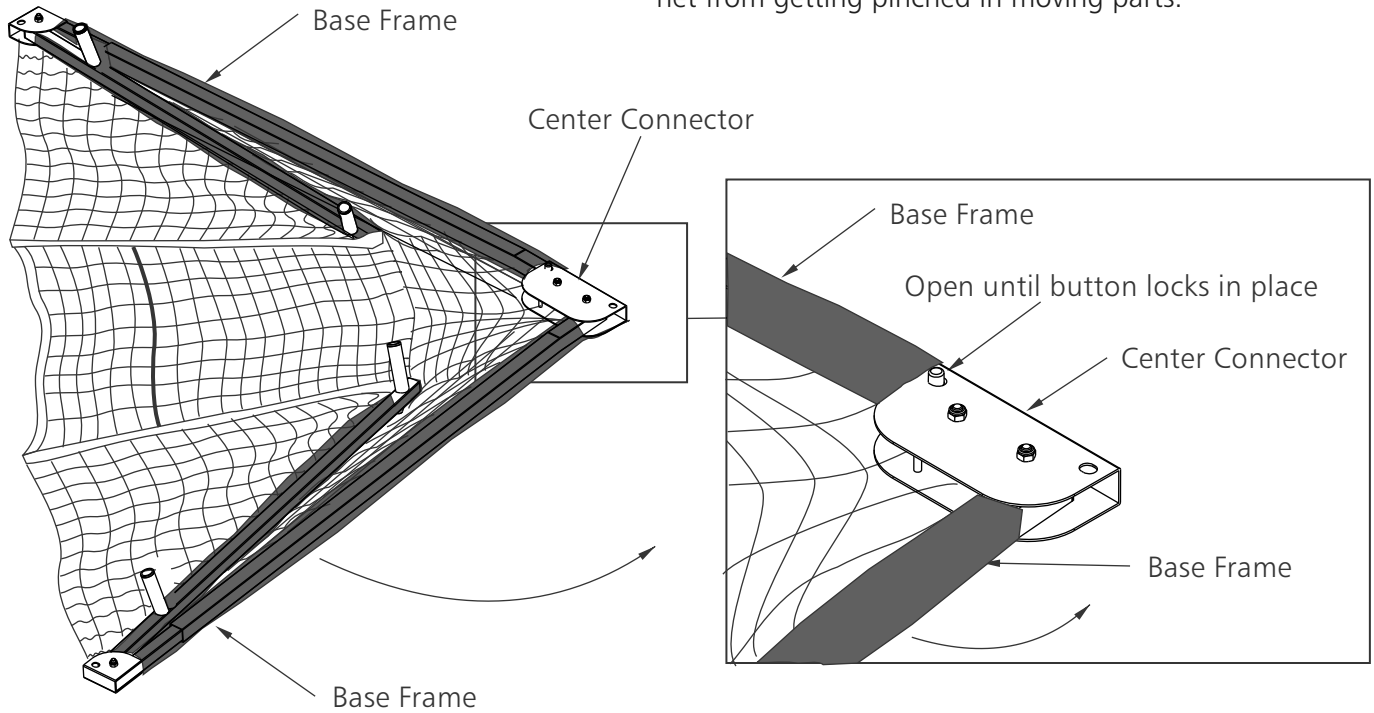

3. Pull left and right rear base until button locks into place on right and left center base. **Do not force parts.** Parts should move freely, if parts do not, look for points where net may be caught on frame.

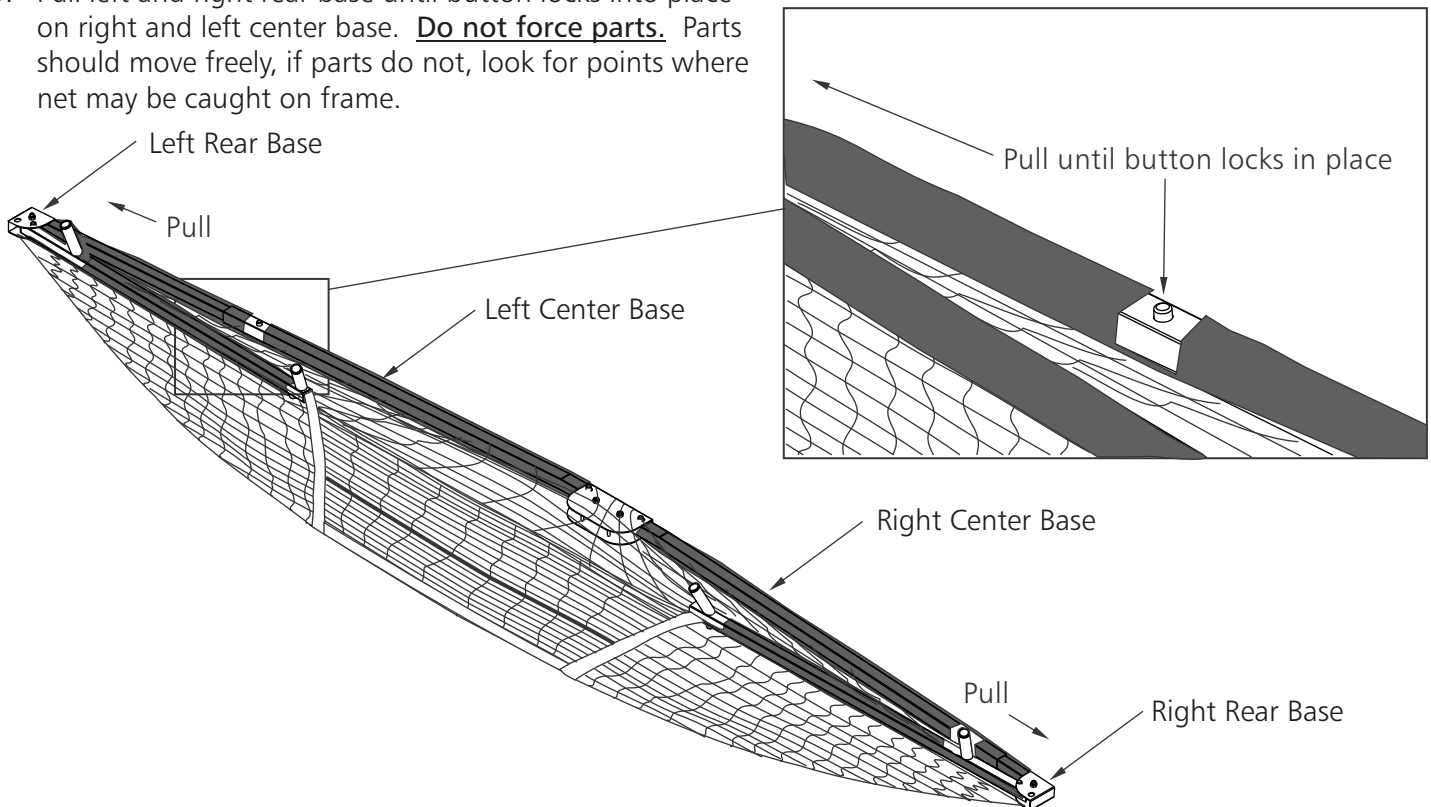

4. Open left and right bases by swinging outward until button locks in place in left and right rear base.

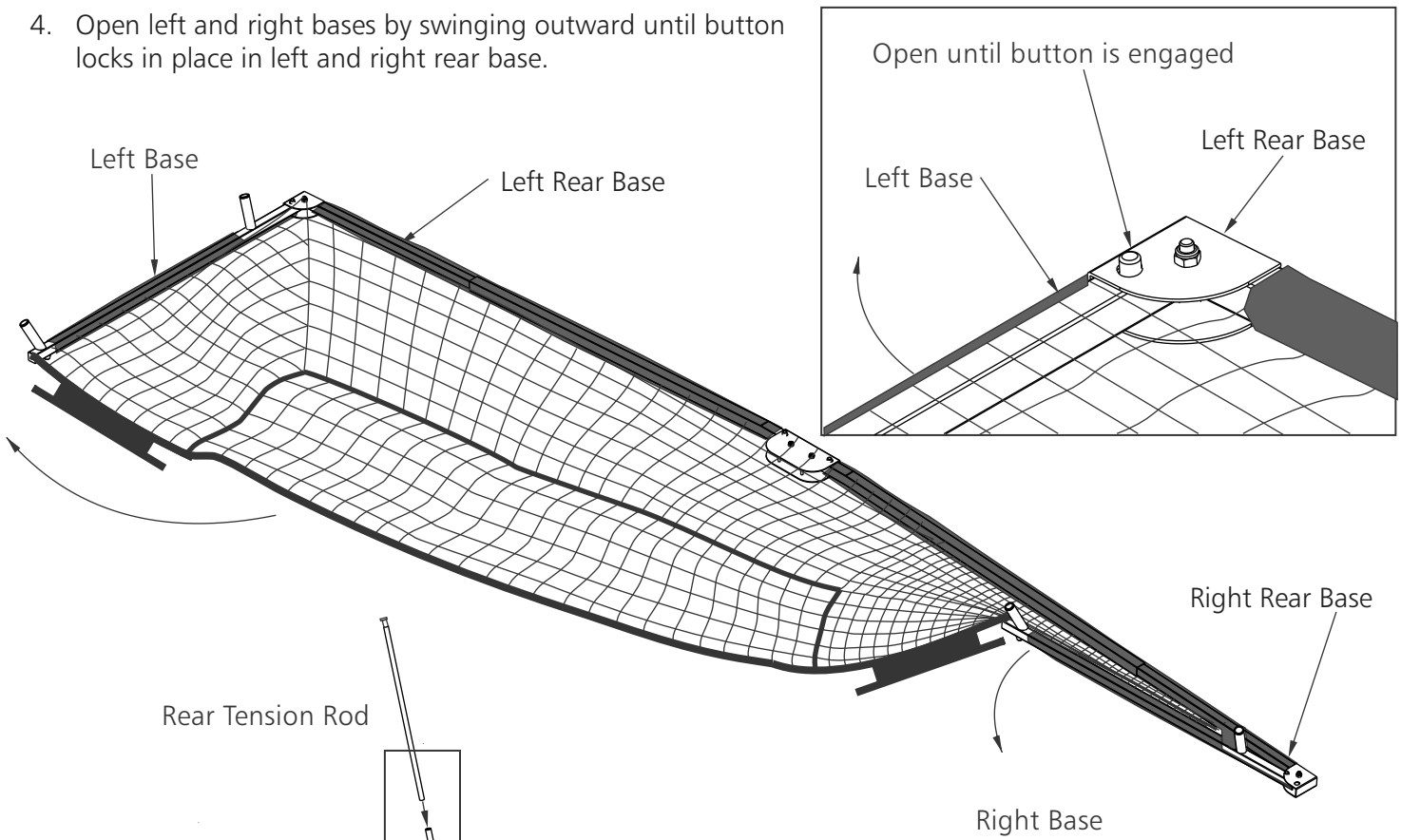

5. Add tension rods to base as shown. Tension rod at front must go through net pocket and elastic strap. Place front tension rods into base holders prior to attaching net loops.

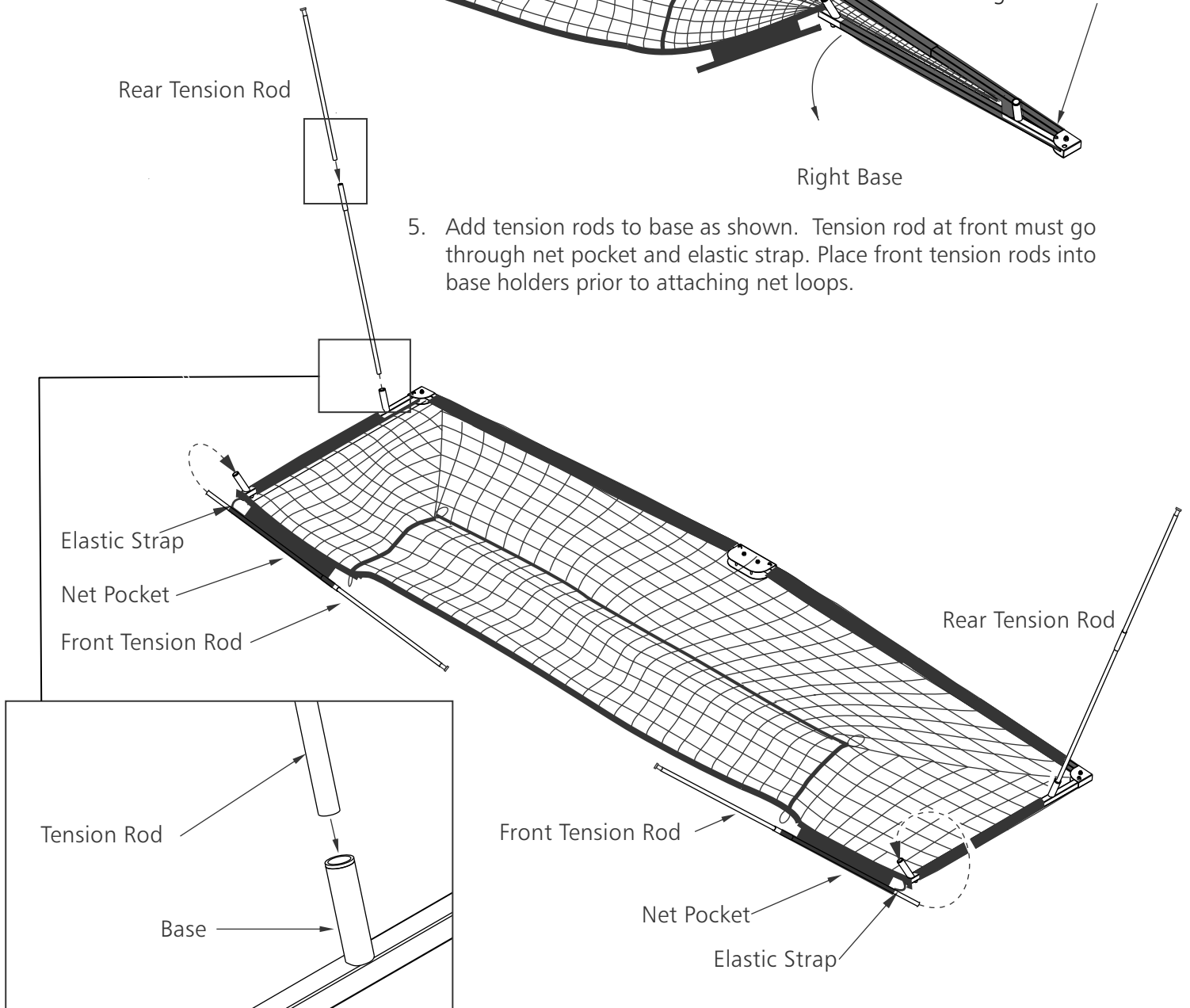

6. Connect top corners of net to tension rod in front by sliding net loop over end of tension rod.

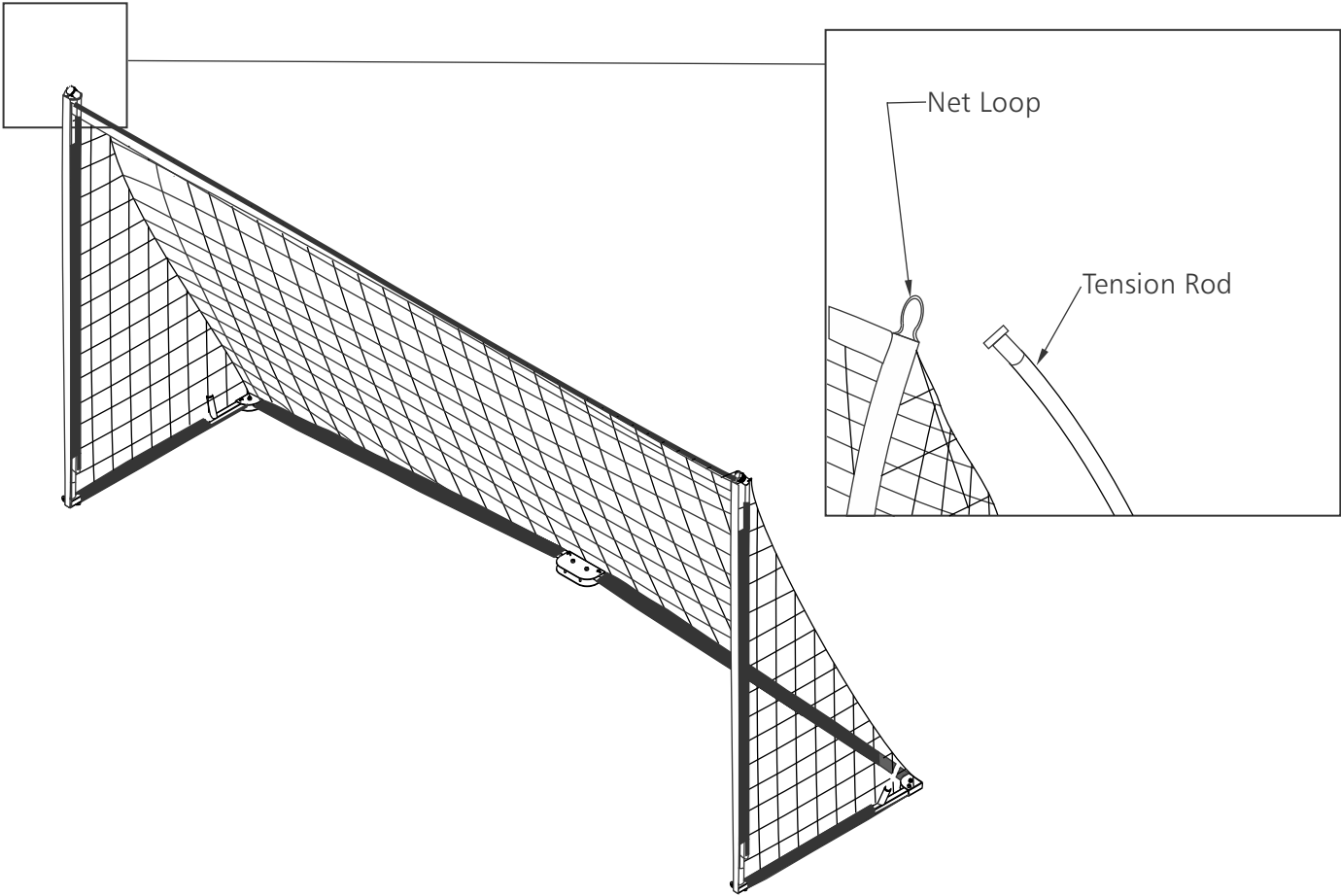

7. Connect backdrop corners of net to tension rod in rear by sliding net loop over end of tension rod.

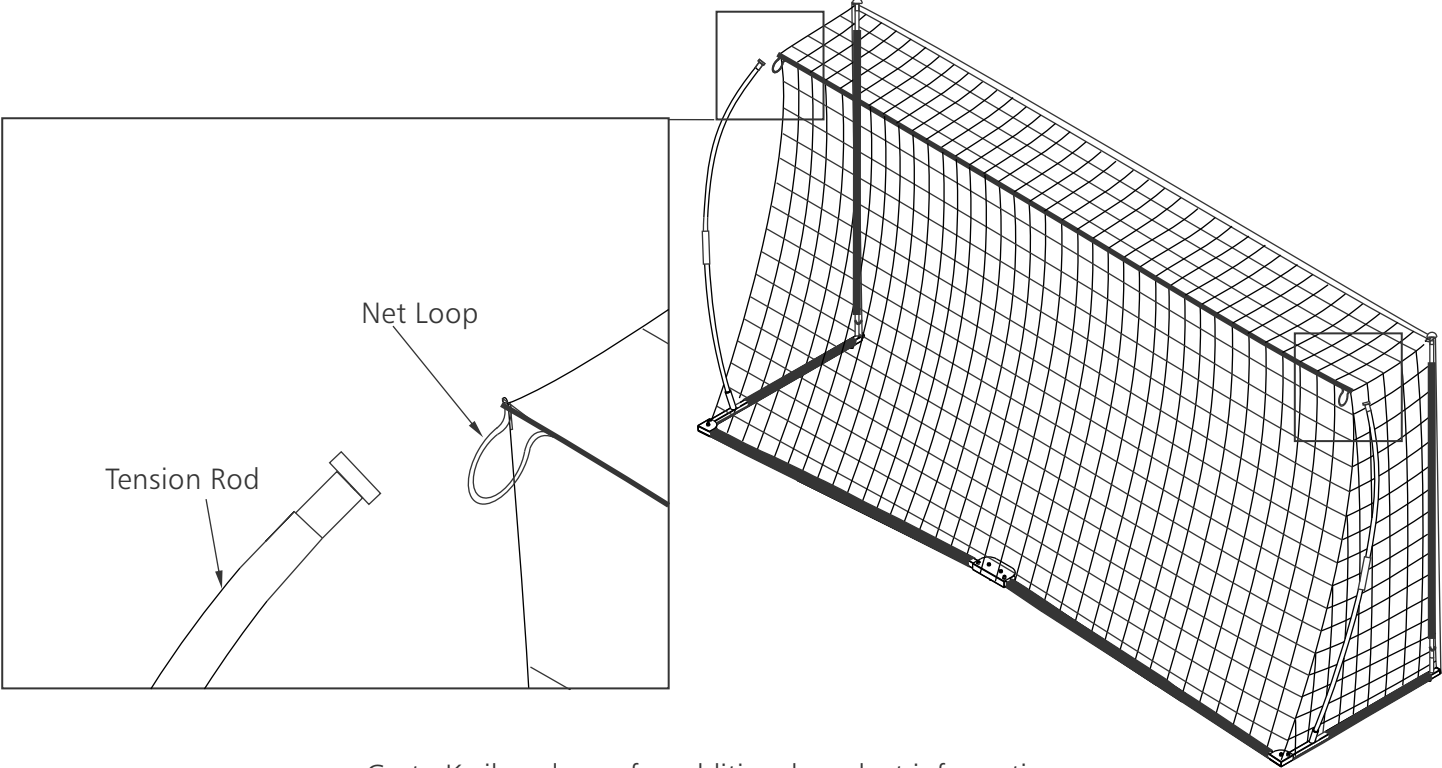

Go to Kwikgoal.com for additional product information.