

FOUNDMI TRACKER USER GUIDE

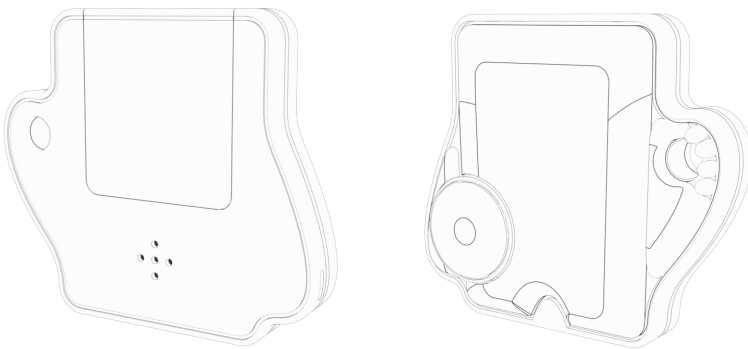

Model 2.0

One61 foundmi Hardware

Here's a guide to the hardware features of the One61 Studio foundmi tracker.

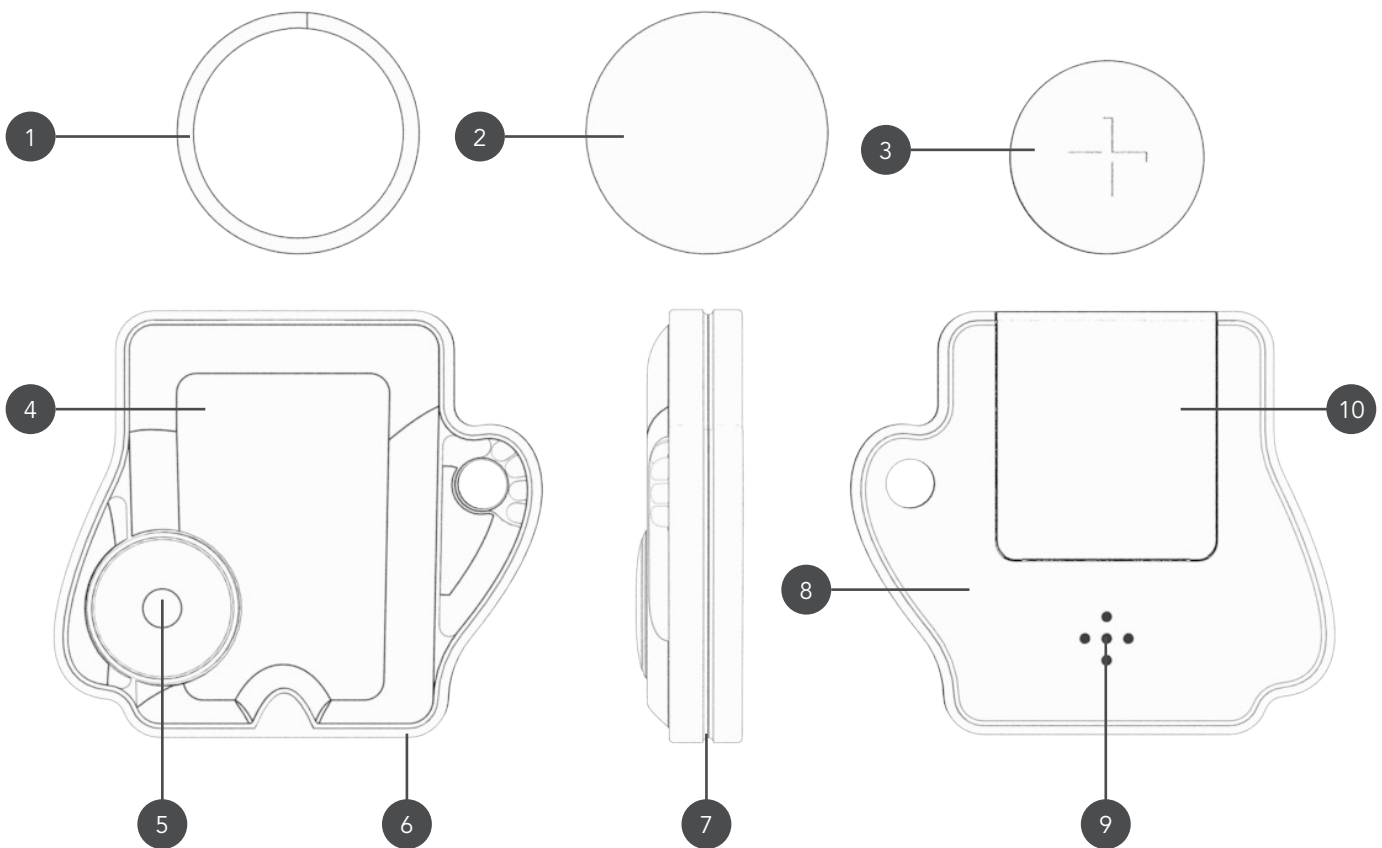

By numbers

- | | |
|---------------------|---------------------------|
| 1. Keyring | 6. ABS front half |
| 2. 3M adhesive disc | 7. Sonically welded sides |
| 3. CR2032 battery | 8. ABS back half |
| 4. Silicone face | 9. Speaker |
| 5. Button | 10. Back door |

One61 Smartwatch tech specs:

Dimensions	50 x 44 x 10.5 mm
Weight	12.6g
Battery	CR2032
Processor	Nordic NRF51
Wireless	Bluetooth Low Energy BLE
Memory	32kb RAM
Embedded Flash	256kb program memory

Foundmi tracker battery removal and replacement

Follow the below steps 1 – 6

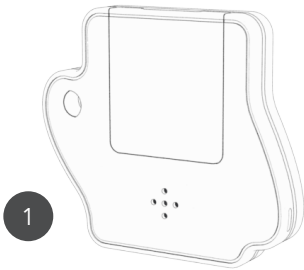

Locate the back door

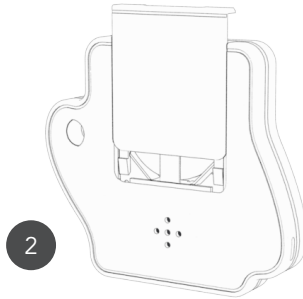

Apply pressure to slide the door up to unlock the back two tabs.

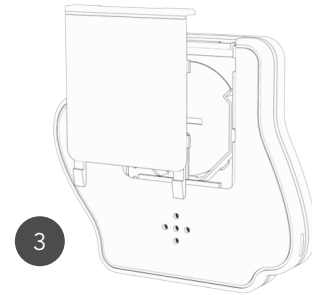

Once its loose, lift the door straight out of the back.

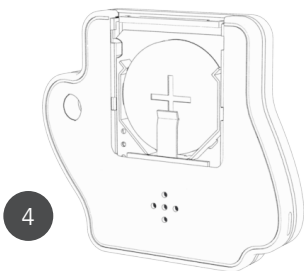

Locate the CR2032 battery. Notice the positive sign is on the top of the battery.

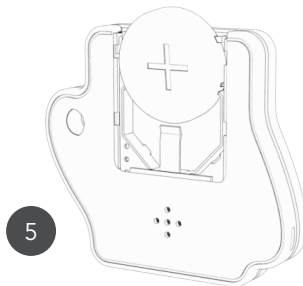

Lift the front edge of the CR2032.

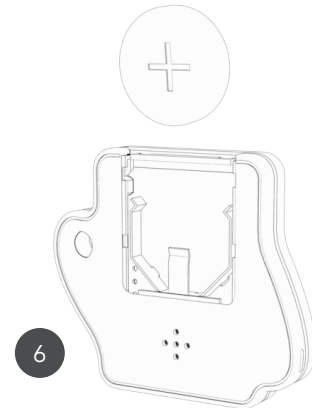

Pull the CR2032 up out of the battery contact.

- Use only CR2032 batteries for the foundmi tracker.
- When replacing the battery always place the positive (+) side up. Refer to step 4 of the removal and replacement steps.
- When replacing the battery follow steps 1-6 in the reverse order.
- Your foundmi tracker is out of battery if pressing the button doesn't cause your foundmi to ring.

Setup and Pairing

Pair your foundmi tracker with your Device

Your foundmi tracker works together with your mobile device, so you'll need to pair them. The foundmi tracker uses Bluetooth Low Energy (BLE).

If you're pairing your foundmi tracker for the first time, make sure your device Bluetooth is turned on and your device is connected to mobile data or Wi-Fi. You need a data connection to complete setup.

How to pair:

- Download and install the foundmi app on your device, which can be found on the Google Play or Apple AppStore by searching "foundmi."
- Open the foundmi app on your device and follow the onscreen prompts..
- On your device, you will need to create an account in the foundmi app.

1. Launch the app
2. Tap 'Signup', 'Facebook', or 'Google +'

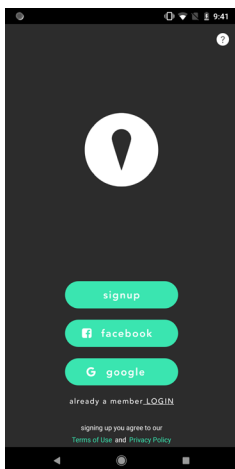

3. Enter your valid email address
4. Enter your name or desired username
5. Enter a password

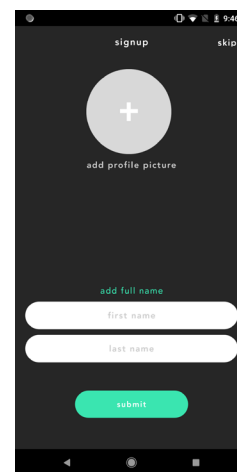
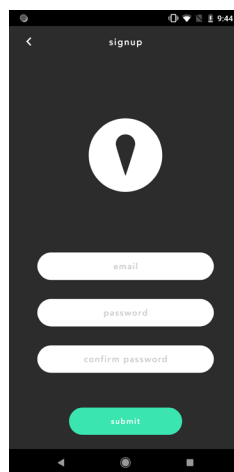
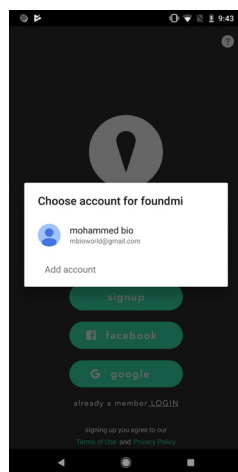
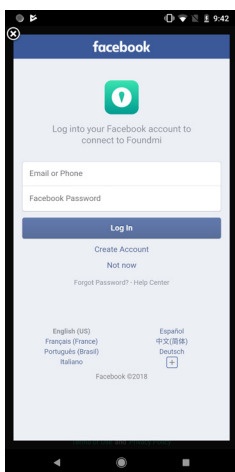

6. Tap 'Submit'

- Once you have completed your signup, you can now pair your foundmi.

1. Tap the + icon in the center of the card to 'add foundmi'

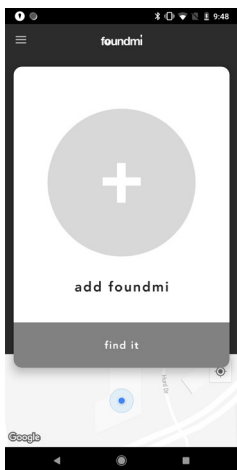

2. Select the universe of your character by tapping on one of the licensed boxes.

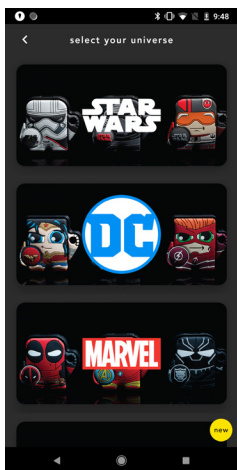

3. Select your character.

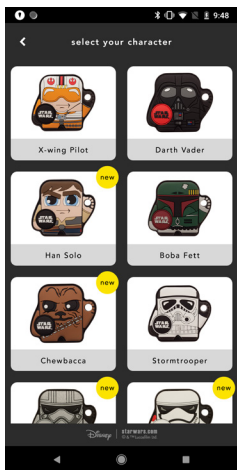

4. Place your foundmi tracker close to your mobile device.

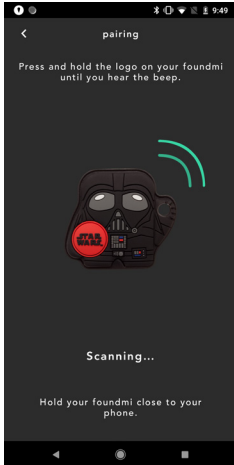

5. Long press the button on your foundmi tracker until it 'beeps' to start pairing.

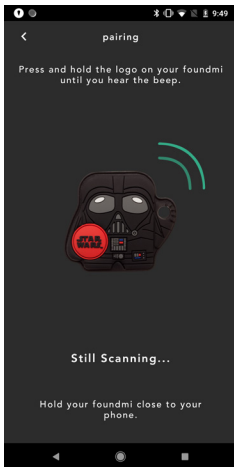

6. You will receive a Bluetooth pairing request notification on your mobile device.

7. Tap 'Pair'

8. Name your character.

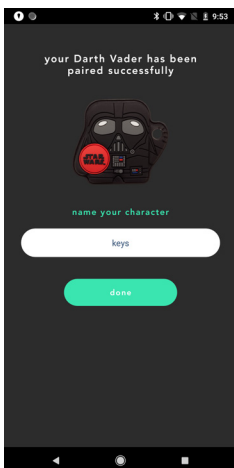

9. Tap the 'test' button to make sure you are paired.

10. "Is your foundmi ringing?" Tap yes or tap try again if it is not.

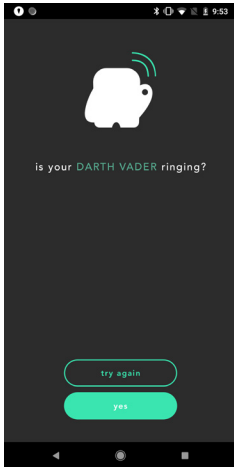

11. If it is not then follow steps G – J again.

12. If you tap 'Yes' you will be redirected back to the main page.

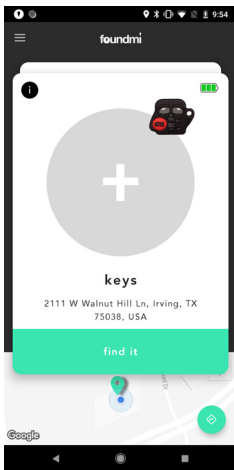

13. Pairing is now complete.

Removing a foundmi tracker

Remove your foundmi tracker from your mobile device

Follow steps 1-3:

1. Tap the 'i' icon in the top left corner of the character card.

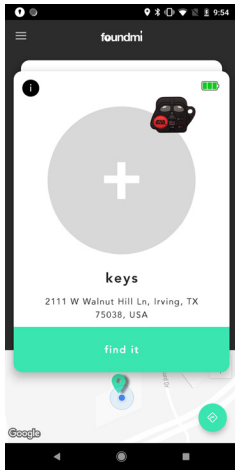

2. Tap "trash can" icon in the top corner.



3. Tap "delete" to remove the foundmi from your mobile device.

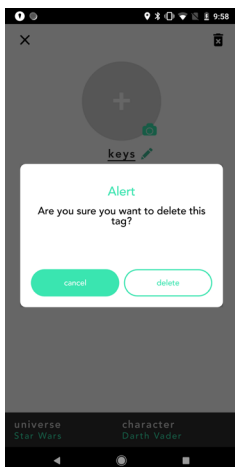

Finding Function

Find your foundmi tracker from your mobile device

Follow steps 1-2:

Make sure that the find button is green on the character card, if it is gray it is out of range.

1. Tap the 'find it' button your foundmi tracker should start ringing.

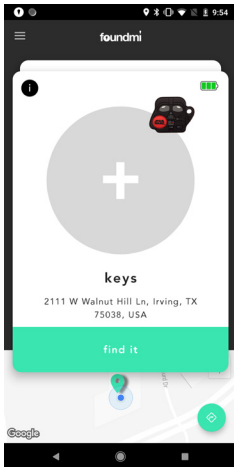

2. Tap "stop" button once you have found your foundmi tracker.

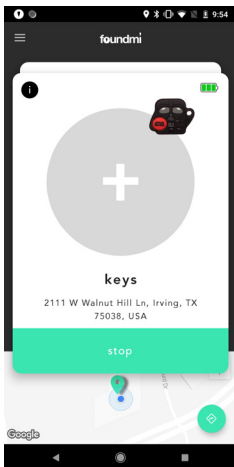

Find your mobile device using your foundmi tracker

Follow steps 1-2:

1. Double click the button on the foundmi tracker .
2. Once you have found your mobile device tap 'dismiss.'

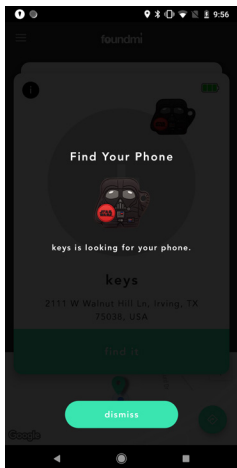

Edit a foundmi tracker

Follow steps 1-2:

1. Tap the 'i' icon in the top left corner of the character card.

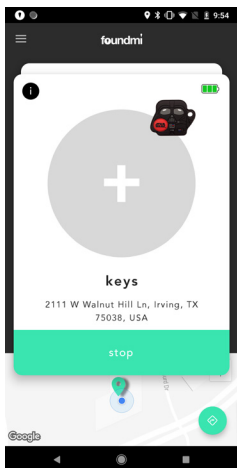

2. Tap "pencil" icon in the center to change the name.



Reset and Change Password

To reset your password

Follow steps 1-3:

1. Tap 'forgot password.'
2. Enter your email address.
3. Tap 'submit.'

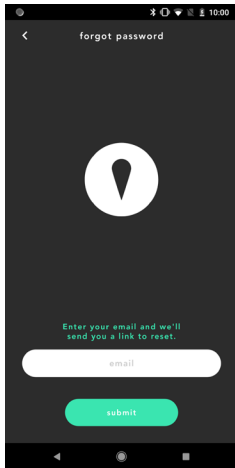

To change your password

Follow steps 1-3:

1. Type in your current password.
2. Type in your new password.
3. Type in and confirm your new password.
4. Tap 'update' to complete the password change.

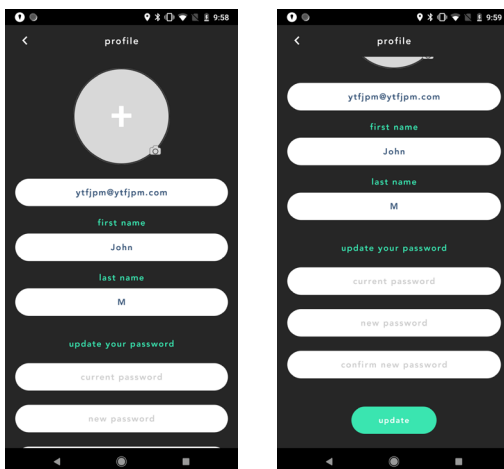

Maps

Need to find your foundmi tracker when it is out of range

This will show your last known location when out of BLE range. It will update when you are within BLE range

To use the maps function

Follow steps 1-3:

1. Tap or swipe up on the map below the character card.

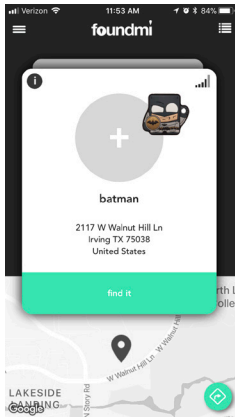

2. The pin shows your foundmi tracker's last known location. You can also tap 'find it' in the top left corner.

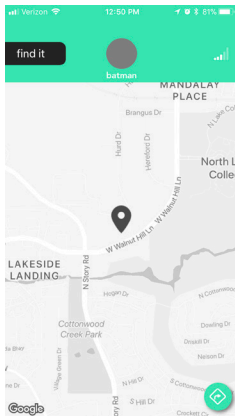

3. Tap 'stop' to stop the find it function

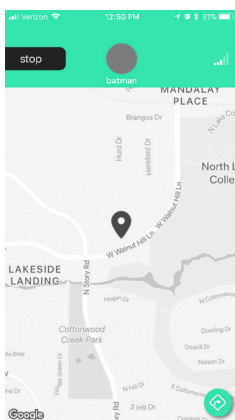

Selfie Function

In-app camera

The in-app camera allows you to use your tracker to take pictures.

To use the selfie function:

1. Tap on the 'menu' icon or swipe from the left side of the screen to open up the menu.
2. Tap 'selfie.'

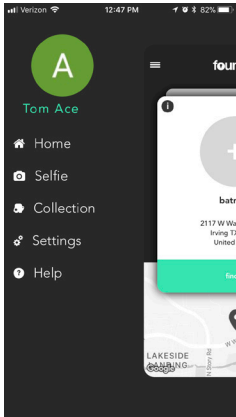

3. Once in the app you can tap the white ring to snap a photo or use your foundmi as a shutter button.



4. After taking a photo you can choose save it and share it.



5. If you tap 'save' a notification will request permission to save the photo to your local photo library.

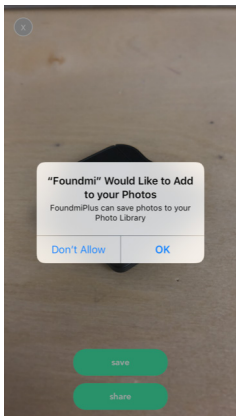

6. If you tap 'share' a notification will request if you would like to continue, and from there you can choose the way you share your photo.

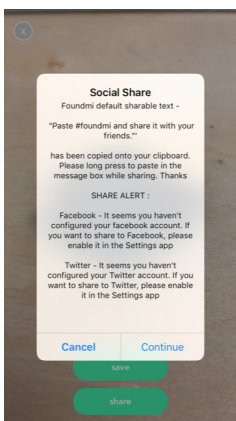

Collections

To view your collections

Follow steps 1-3:

1. Tap on the 'menu' icon or swipe from the left side of the screen to open up the menu.
2. Tap 'collection'

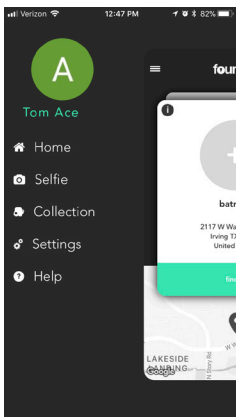

3. Scroll up and down to view all of the characters.

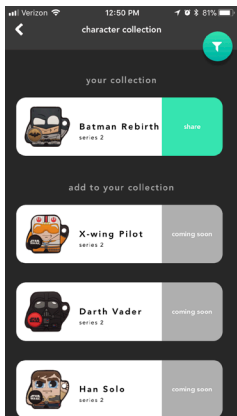

4. Tap the 'filter' icon to see all the different licenses to choose from and to narrow down your search.

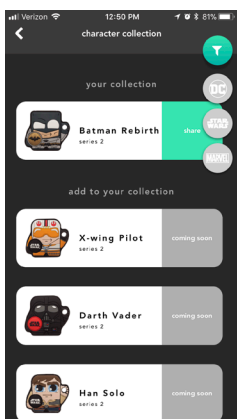

Setting

Follow steps 1-3:

1. Tap on the 'menu' icon or swipe from the left hand side of the screen to open up the menu.
2. Tap 'settings'
3. You will then be given 3 items
 - A. Device Trigger
 - Find my phone
 - Ringtone
 - Change the 'find my phone' tone
 - B. Tutorial
 - Shows the device tutorials.
 - C. Foundmi version
 - Shows which version of the foundmi app you're currently running.

Help

Follow steps 1-3:

1. Tap on the 'menu' icon or swipe from the left side of the screen to open up the menu.
2. Tap 'help'
3. You will then be given 4 options:
 - A. Instruction manual
 - Directs you to the foundmi.com website and this document.
 - B. FAQ
 - Directs you to the foundmi.com website and the FAQ page.
 - C. Contact us
 - Directs you to the foundmi.com website and the contact us page.
 - D. Compatibility
 - Directs you to the foundmi.com website and the device compatibility page.