

ASUNA

7150

***Minotaur Magnetic
Commercial Indoor Cycling Bike***



***Owner's Manual
Made in Taiwan***

INDEX

IMPORTANT SAFETY INFORMATION	1
EXPLODED DRAWING	2
PARTS LIST.....	3
ASSEMBLY INSTRUCTION.....	4-9
USER INSTRUCTION	10
MAINTENANCE	11
EXERCISE INSTRUCTION	12-13

ATTENTION: Please verify that all parts associated with this product are in good condition and accounted for. During the assembly process please be sure to follow each step accordingly as it has been explained within the manual.



WARNING: During assembly it is recommended that all bolts be tightened by hand, upon completing assembly, bolts should then be properly secured using the wrench provided. To avoid injury, check bolts carefully before use.



WARNING: This product can expose you to one or more chemicals known to the State of California to cause cancer and birth defects or reproductive harm. For more information go to www.P65Warnings.ca.gov.

IMPORTANT: Read all instructions carefully before using this product. Retain owner's manual for future reference. For customer service, please contact: support@sunnyhealthfitness.com

IMPORTANT SAFETY INFORMATION

We thank you for choosing our product. To ensure your safety and health, please use this equipment correctly. It is important to read this entire manual before assembling and using the equipment. Safe and effective use can only be achieved if the equipment is assembled, maintained and used properly. It is your responsibility to ensure that all users of the equipment are informed of all warnings and precautions.

1. Before starting any exercise program you should consult your physician to determine if you have any medical or physical conditions that could put your health and safety at risk, or prevent you from using the equipment properly. Your physician's advice is essential if you are taking medication that affects your heart rate, blood pressure or cholesterol level.
2. Be aware of your body's signals. Incorrect or excessive exercise can damage your health. Stop exercising if you experience any of the following symptoms: pain, tightness in your chest, irregular heartbeat, and extreme shortness of breath, lightheadedness, dizziness or feelings of nausea. If you do experience any of these conditions, you should consult your physician before continuing with your exercise program.
3. Keep children and pets away from the equipment. The equipment is designed for adult use only.
4. Use the equipment on a solid, flat level surface with a protective cover for your floor or carpet. To ensure safety, the equipment should have at least 2 feet of free space all around it.
5. Ensure that all nuts and bolts are securely tightened before using the equipment. The safety of the equipment can only be maintained if it is regularly examined for damage and/or wear and tear.
6. It is recommended that you lubricate all moving parts on a monthly basis.
7. Always use the equipment as indicated. If you find any defective components while assembling or checking the equipment, or if you hear any unusual noises coming from the equipment during exercise, stop using the equipment immediately and don't use the equipment until the problem has been rectified.
8. Wear suitable clothing while using the equipment. Avoid wearing loose clothing that may become entangled in the equipment. Do not use bike without shoes, or with loose shoes.
9. Do not place fingers or objects into moving parts of the exercise equipment.
10. The maximum weight capacity of this unit is 330 pounds.
11. The equipment is not suitable for therapeutic use.
12. You must take care of yourself when lifting and moving the equipment so as not to injure your back. Always use proper lifting technique and seek assistance if necessary.
13. For all adjustable parts be aware of the maximum position to which they can be adjusted.
14. Be aware of non-fixed or moving parts while mounting or dismounting the bike.
15. We take no responsibility for personal injury or damage sustained by or through the use of this exercise bike.

Exploded Drawing

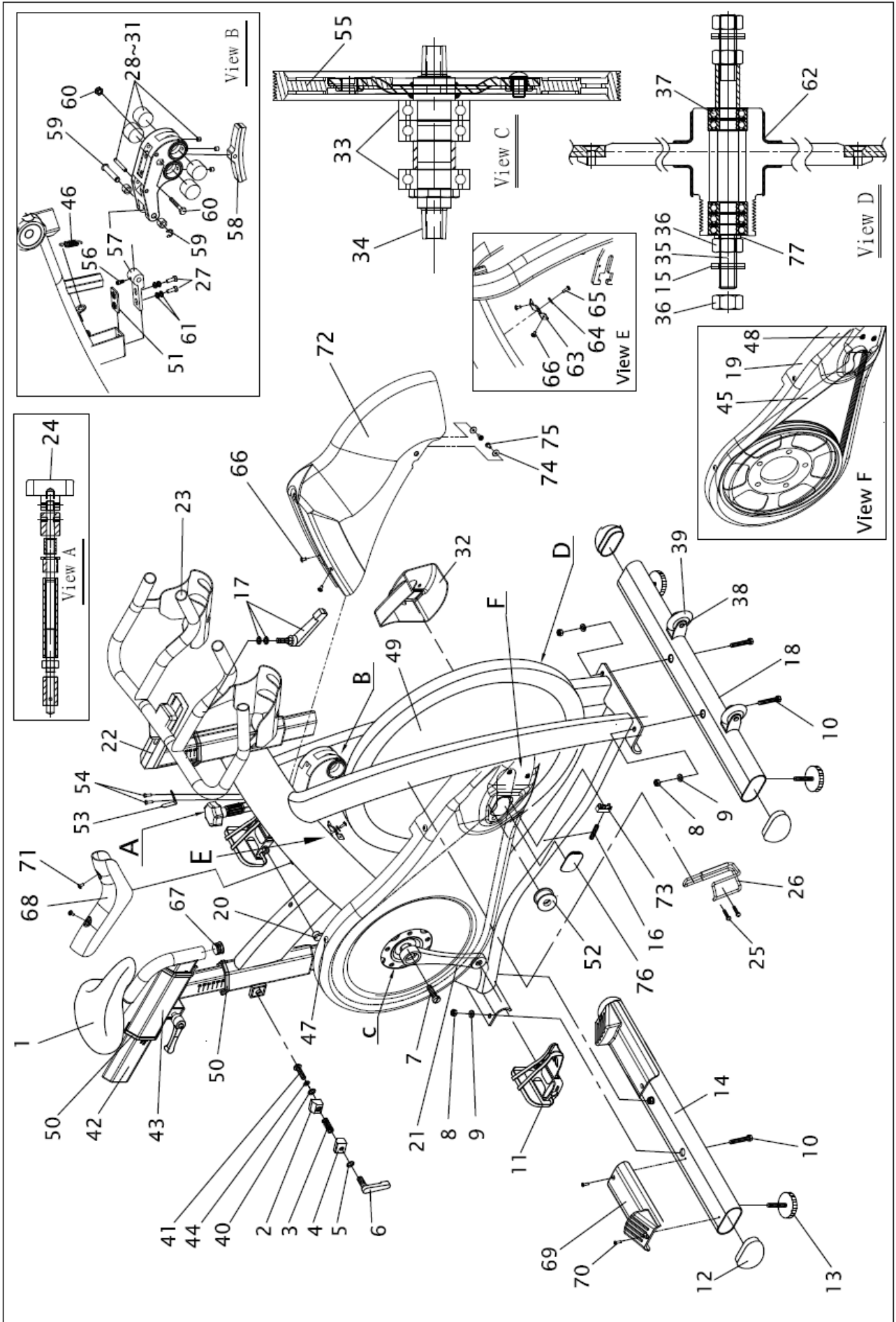

REF.	Name	Q'TY	REF.	Name	Q'TY
1	Saddle	1	39	Moving wheels	2
2	Alloy bind clamp (L)	3	40	Plastic washer for release lever	3
3	Spring for release lever	3	41	Fixed bolt for release lever	3
4	Alloy bind clamp (R)	3	42	Seat slider	1
5	Washer for release lever	3	43	Seat post	1
6	Release lever	3	44	Washer for release lever	3
7	Crank bolt	2	45	Belt	1
8	Nut	4	46	Spring	1
9	Washer	4	47	Outer chain guard bolt M5	5
10	Bolt	4	48	Outer chain guard bolt M6	4
11	Pedal	1	49	Flywheel	1
12	End cap	4	50	Bushing	6
13	Adjuster pad	4	51	Plate for screw	1
14	Rear Stabilizer	1	52	Idler w/bearing, clip	1
15	Flywheel security washer	4	53	Sprocket bracket for resistance knob	1
16	Flywheel adjuster screw	2	54	Bolt for sprocket bracket	2
17	L Shape Adjustment Knob	1	55	Pulley with screw	1
18	Front Stabilizer	1	56	Bolt	1
19	Outer belt guard	1	57	Connection bracket	1
20	Left Crank Arm	1	58	Brake pad w/holder	1
21	Right Crank Arm	1	59	E clip w/fixed pin	1
22	Handlebar post	1	60	Screw & nut for brake pad	1
23	Handlebar	1	61	Washer	4
24	Tension knob	1	62	Rubber cover for flywheel	2
25	Bottle Holder Bolts	2	63	Fixed plate for fender	1
26	Bottle Holder	1	64	Washer for fixed plate	1
27	Screw & washer for plate	2	65	Bolt for fixed plate	1
28~31	Magnetic holder w/magnetic, bolt , fixed pin	1	66	Screw for fixed plate	2
32	Left axle cover	1	67	End cap	1
33	BB bearing	3	68	Top protect cover	1
34	BB Axle with plate	1	69	Rear foot tube cover	2
35	Flywheel axle	1	70	Screw for foot tube cover	4
36	Flywheel security nut		71	Top protect cover bolt M5	1
37	Flywheel bearing		72	Fender	2
15	Flywheel security washer		73	Flywheel adjuster plate	2
77	Flywheel security washer		74	Washer for fender	2
36	Flywheel security nut		75	Screw for fender	2
37	Flywheel bearing	5	76	Rubber cover	1
38	Axle bolt for moving wheel	2	77	Flywheel security washer	1

TOOLS TO USE

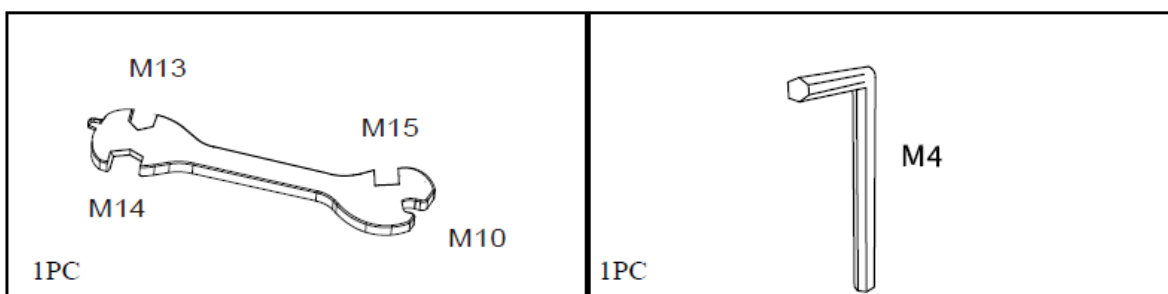

NOTE: All hardware items have been preinstalled on the machine, simply remove and reinstall the hardware as assembly is required.

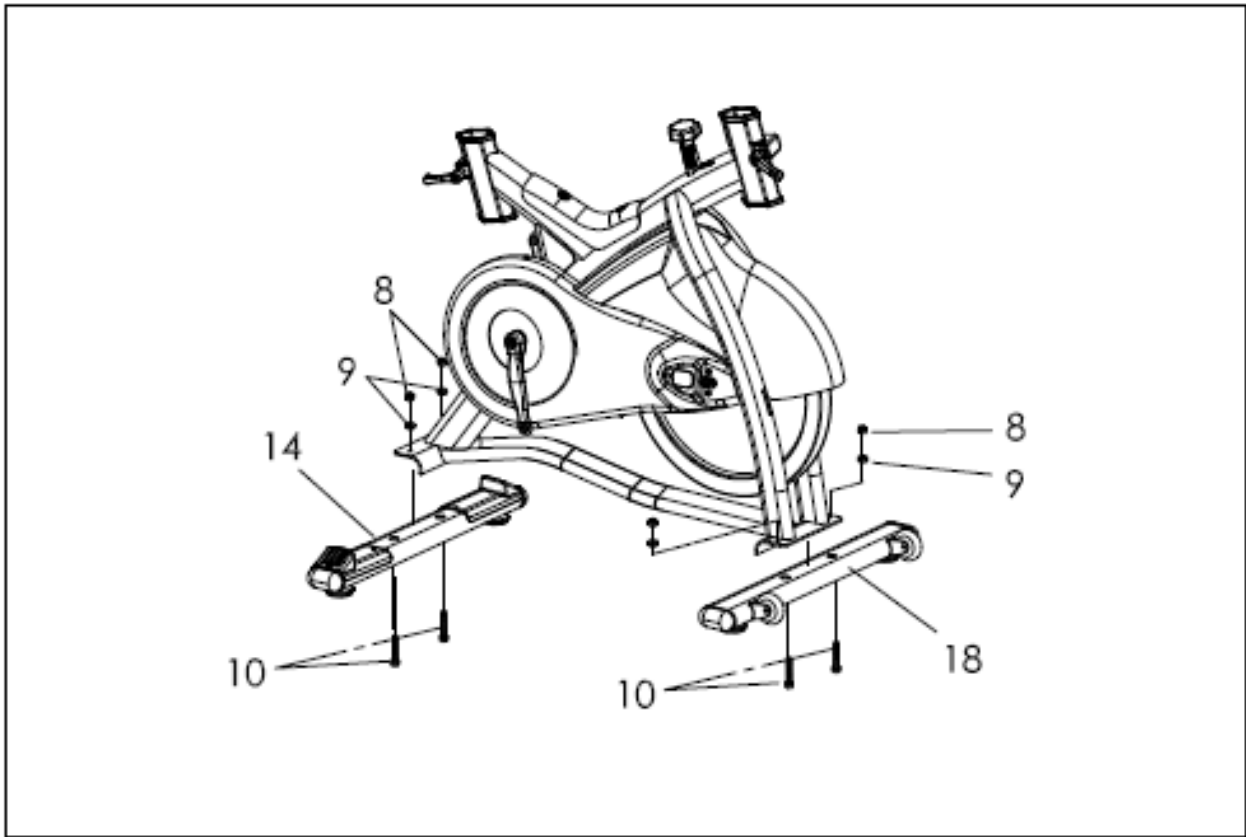

Attach the **Front Stabilizer (18)** and the **Rear Stabilizer (14)** to the Main Frame using 4 **Bolts (10)**, 4 **Washers (9)** and 4 **Nuts (8)**. Tighten and secure using spanner wrench.

STEP: 2

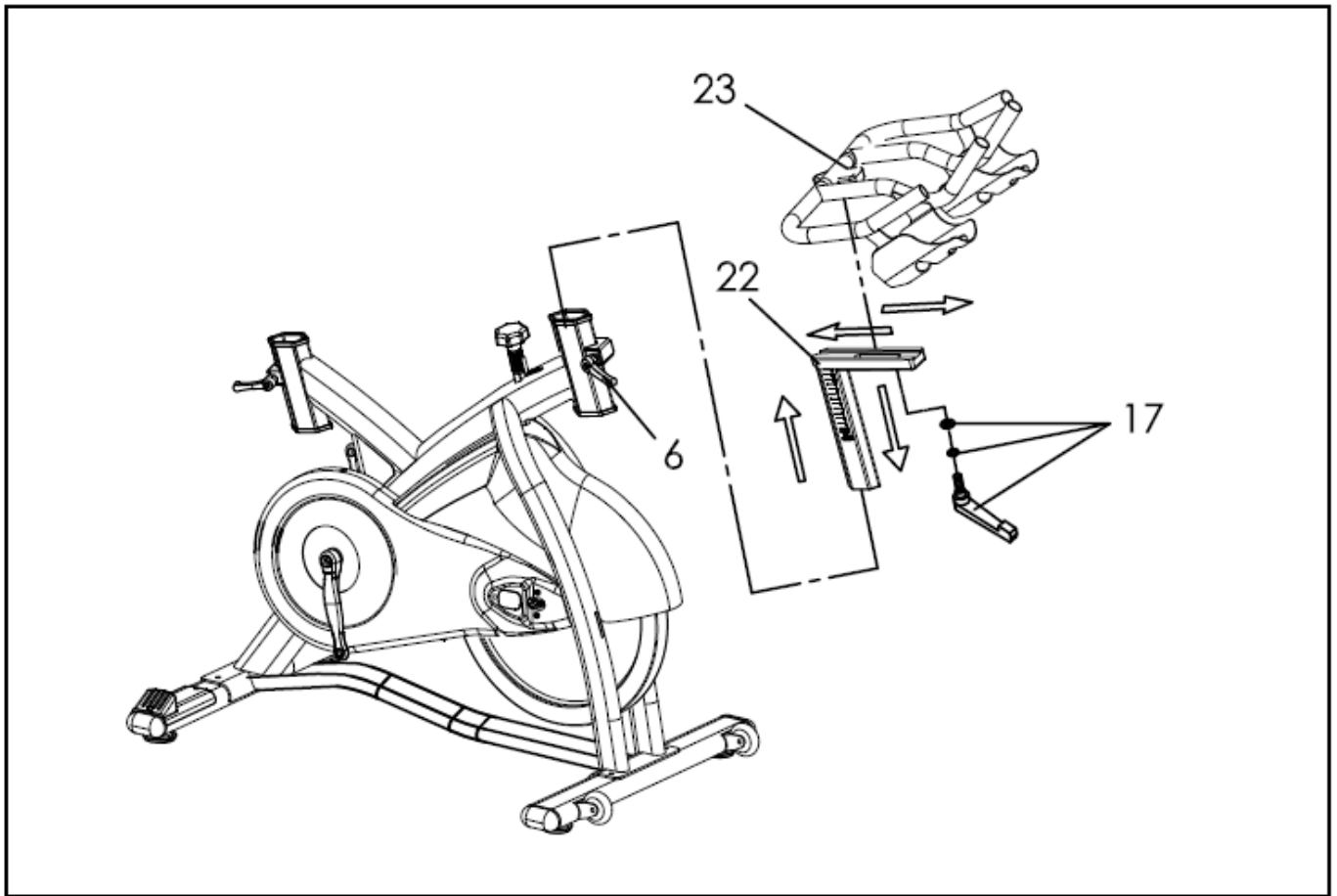

Insert the **Handlebar Post (22)** into the head tube of the Main Frame. Move **Handlebar Post (22)** to the desired height. Tighten the **Release Lever (6)** to secure the **Handlebar Post (22)** into position.

Slide the **Handlebar (23)** onto the **Handlebar Post (22)**. Tighten the **L Shape Adjustment Knob (17)** to secure the **Handlebar (23)** into position.

NOTE: To slide the **Handlebar (23)** back and forth to adjust it to the desired position, first loosen the **L Shape Adjustment Knob (17)**.

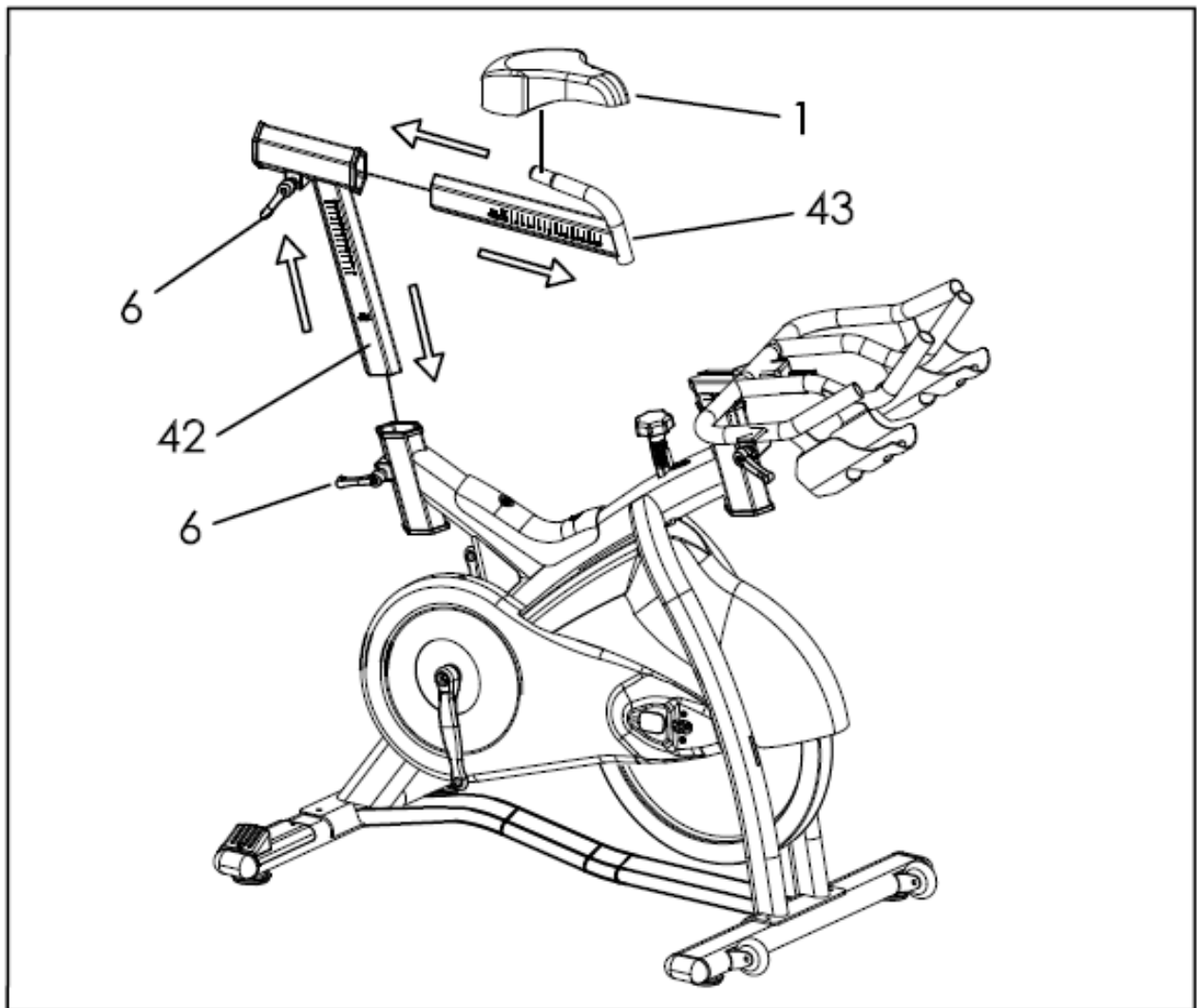

Insert the **Seat Post (42)** into the seat tube located on the Main Frame.

Insert the **Seat Slider (43)** into the **Seat Post (42)**. Tighten the **Release Lever (6)** to secure the **Seat Slider (43)** in place.

Secure the **Saddle (1)** onto the post of the **Seat Slider (43)**. Tighten the saddle clamp screw to secure the **Saddle (1)** in place.

Use **Release Lever (6)** to adjust height of the saddle, use **Release Lever (6)** to adjust the saddle back and forth.

STEP: 4

IMPORTANT:

Read instructions carefully, failure to do so may cause permanent damage to your bike.

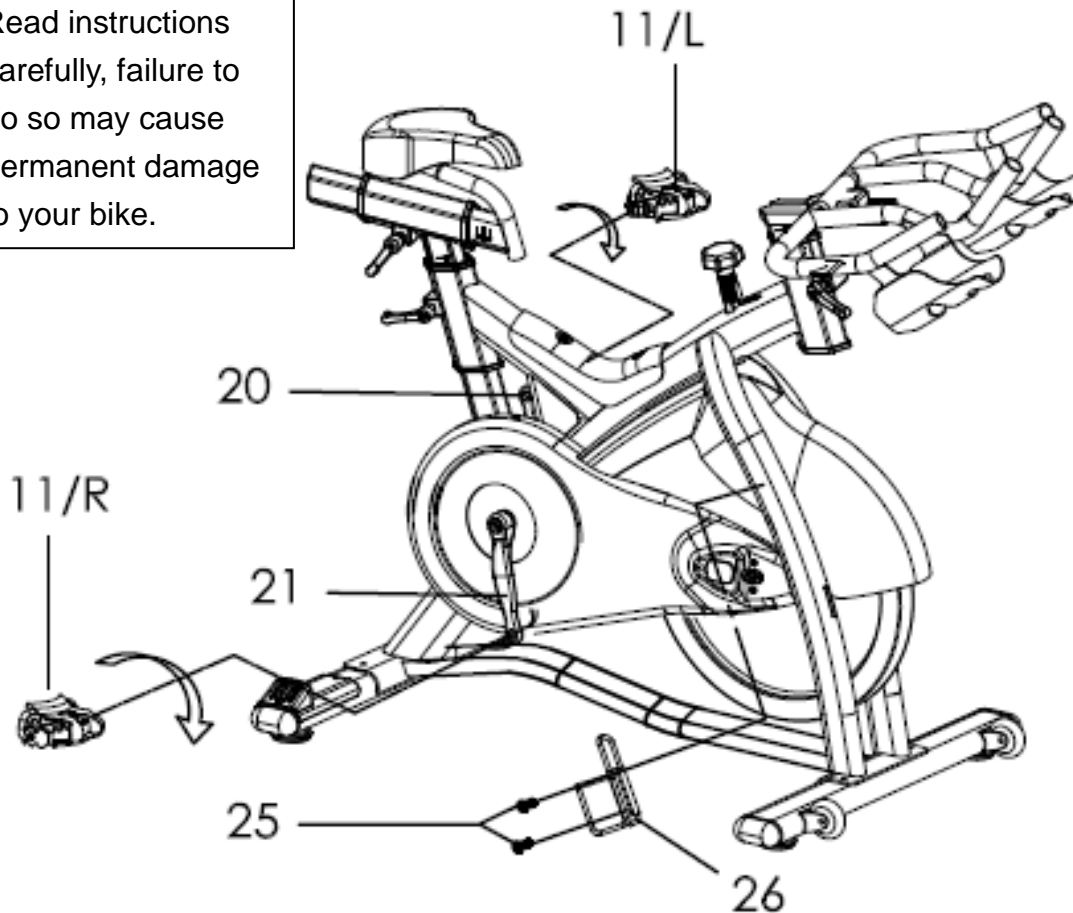

Connect **Pedals L/R (11)** onto the **Left and Right Crank Arm (20 and 21)**. (Before you begin, immobilize the crank arms by turning the tension control knob all the way to the right).

NOTE: Pedals L/R (11) are marked, **L** for the (left pedal) and **R** for the (right pedal).

Left Pedal: align the left pedal, **Pedal L (11)** with the **Left Crank Arm (20)** at 90 degrees. Gently insert the pedal into the crank arm, turn the pedal **counter-clockwise** as tightly as you can with your hand. Tighten and secure with (15mm) spanner wrench.

Right Pedal: align the right pedal, **Pedal R (11)** with the **Right Crank Arm (21)** at 90 degrees. Gently insert the pedal into the crank arm, turn the pedal **clockwise** as tightly as you can with your hand. Tighten and secure with (15mm) spanner wrench.

Attach the **Bottle Holder (26)** to the Main Frame using **2 Bottle Holder Bolts (25)**. Tighten with spanner wrench.

STEP: 5

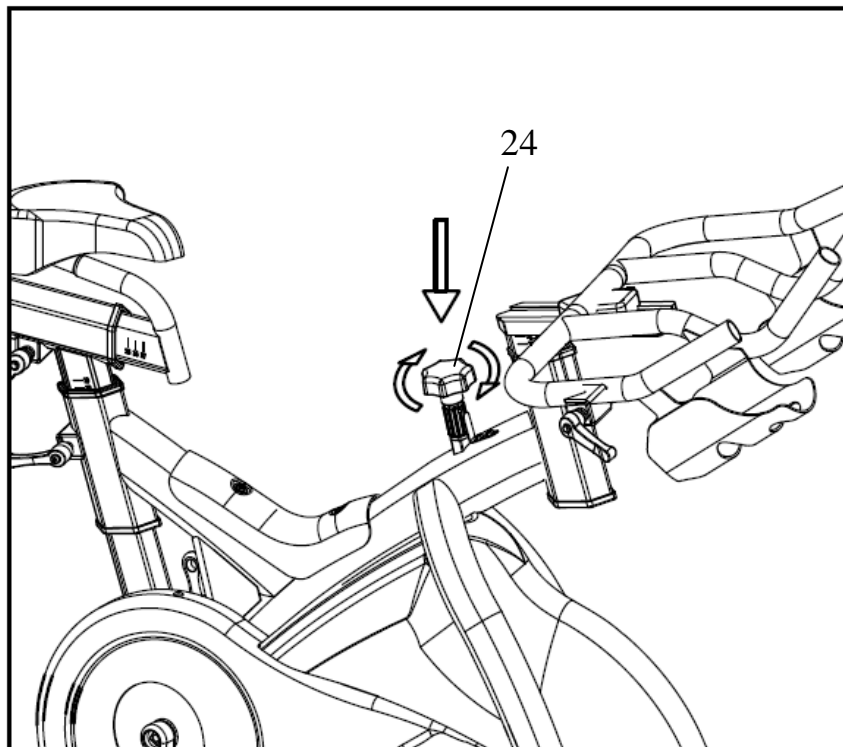

Adjust the exercise resistance on the bike using **The Tension Knob (24)** to increase (-) or decrease (+) resistance.

Emergency brake –Press down **Tension Knob (24)** to stop.

STEP: 6

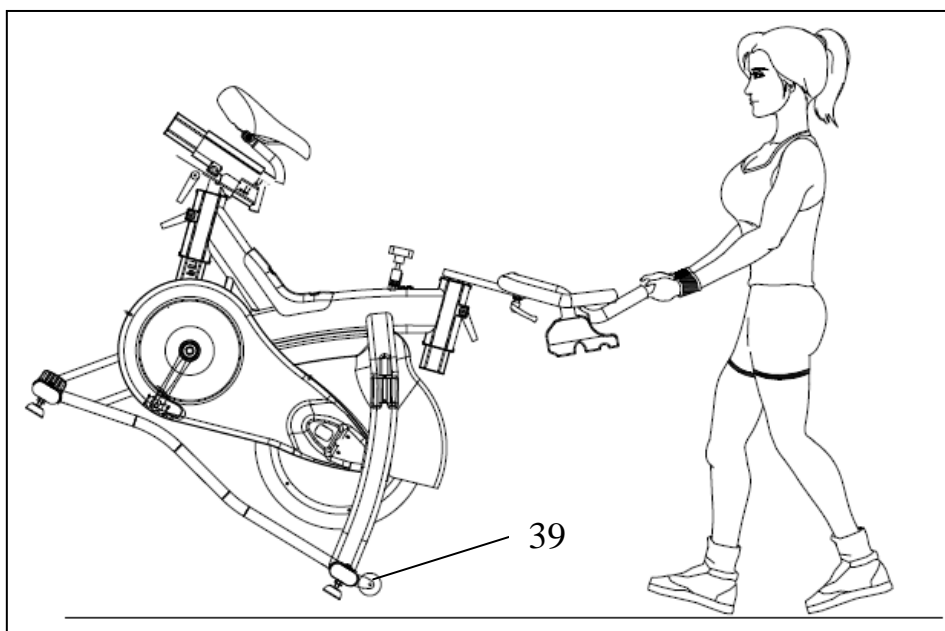

MOVING

There are **Moving Wheels (39)** on the front stabilizer. Hold the handlebar, and tilt the bike towards you until the wheels touch the ground. Then you can move the bike.

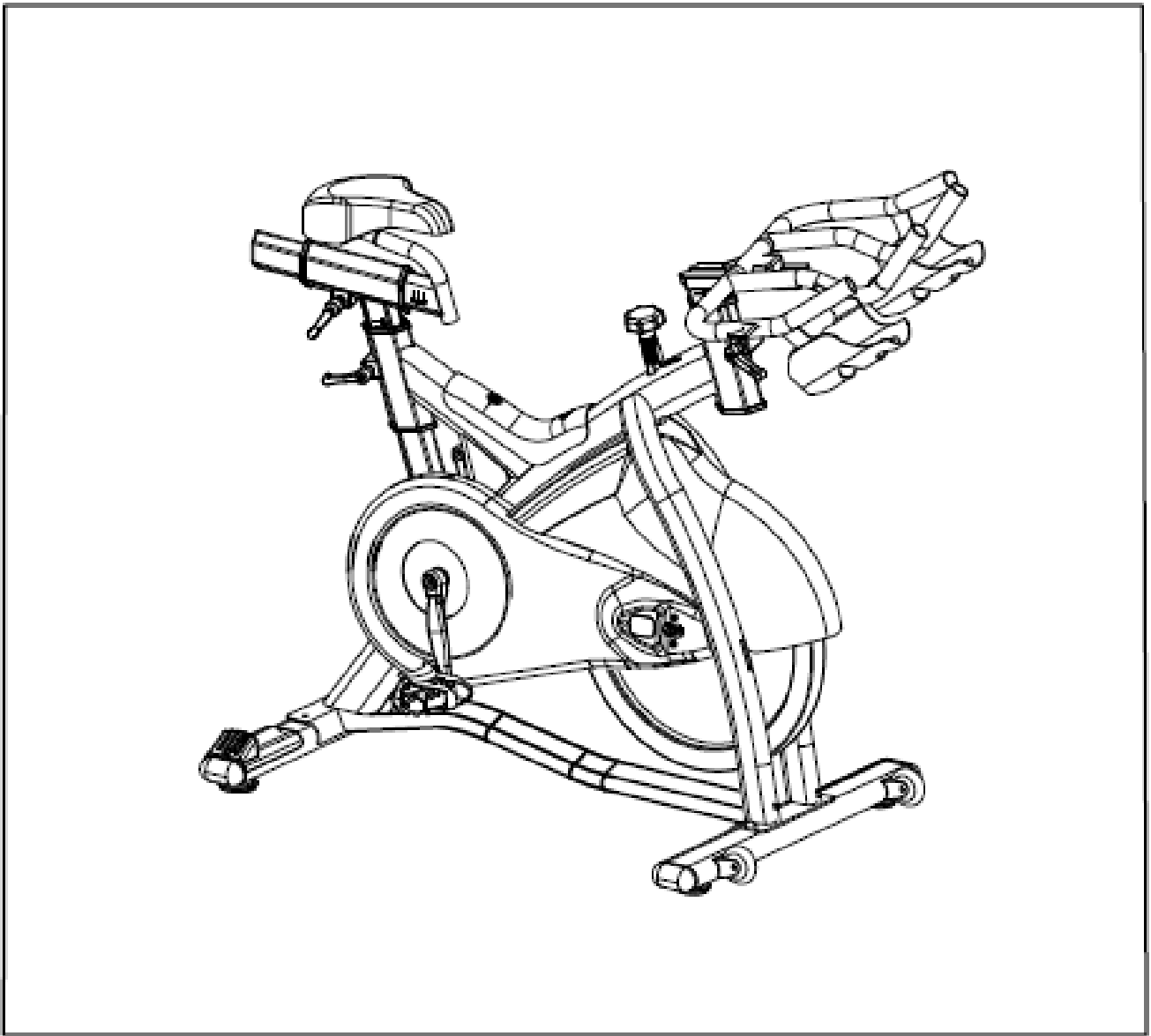

Assembly is complete!

Before beginning use of equipment, please be sure to inspect the entire bike carefully. Ensure that all moving and stationary parts have been properly installed and are operational. Inspect all screws, nuts and bolts as well to make sure that they are tightened and secure.

1. This bike is designed to be used in fitness and health clubs.
2. **Assembly:** properly assembling the equipment before use is very important. Be sure to follow all instructions as detailed in the assembly instructions section of the owner's manual.
3. **Adjusting the resistance:** Adjust the resistance of the bike using the **Tension Knob (24)**. Increase the level of resistance by turning the tension knob to the **RIGHT**, and decrease the level of resistance by turning the tension knob to the **LEFT**.
4. **Handlebar and seat adjustment:** it is important that the handlebar and seat are both set to the correct height of your body. To adjust the handlebar height, loosen the **Handlebar Release Lever (6)** and slide the **Handlebar Post (22)** up or down to the required height. Once adjusted, retighten the handlebar release lever. Ensure that it is securely tightened and that isn't any lateral or vertical movement of the handlebar. The **Handlebar (23)** can also be adjusted forwards or backwards. To do so, loosen the **L Shape Adjustment Knob (17)** located below the handlebar slider. Slide the handlebar assembly forwards and backwards until you reach the required position. Once adjusted retighten the L shape adjustment knob.

Saddle Adjustment. To adjust the saddle height, loosen the **Release Lever (6)**, move the saddle up or down to the required height. Once adjusted, retighten the release lever. Ensure that the release lever is tight enough to prevent the saddle from moving side to side. The **Saddle (1)** can also be adjusted forwards or backwards. To do so, loosen the **Release Lever (6)** located at the top of the **Seat Post (43)**. Slide the **Seat Slider (42)** to the required position. Once adjusted, retighten the release lever.
5. **Pedals and toe straps:** Feet should be securely positioned in the toe clips during exercise. Put your foot as far forwards as you can into the toe-clip and then pull the strap tight. Repeat this process to secure your other foot.
6. **Adjusting the height of the bike:** Located underneath the Front and Rear Stabilizers of the bike are height adjustment pads. These pads are used to adjust the height of the bike in order to increase the amount of stability to the ground. To increase the height of the bike, turn the adjustment pad counter-clockwise. To decrease the height of the bike, turn the adjustment pad clockwise.
7. **Brake:** to stop the bike, press down on the **Tension Knob (24)** located at the top of the Main Frame.

Maintenance

IMPORTANT:

Safe and effective use can only be achieved if the equipment is assembled, maintained and used properly. It is your responsibility to ensure that the equipment is maintained regularly. Any components found to be worn and/or damaged should be replaced before continuing use of the equipment. Equipment should only be used and stored indoors. Prolonged exposure to weathering and changes in temperature and humidity may have a severe impact on electrical components and moving parts of the machine.

Daily Maintenance:

- Clean and remove sweat and moisture after each use.
- Inspect all nuts and bolts associated with moving parts of the equipment, and tighten as required.
- Check the mobility of moving parts and components on the equipment, and lubricate if required.
- Clean plastic parts of the equipment using a damp cloth, clean metal parts of the equipment using a dry cloth. Do not use cleaning products to clean the equipment.

Weekly Maintenance:

- Thoroughly inspect the parts of the equipment; nuts, bolts, screws and moving parts such as foot pedals, saddle, pulley's, etc. Tighten or replace parts as required.

Monthly Maintenance:

- Inspect the frame and inner working components for wear and tear as well as damage. Perform maintenance or replace as required.

NOTE:

Using the (ASUNA Indoor Cycling Bike) provides you with several benefits, it will improve your physical fitness, tone muscle and in conjunction with calorie controlled diet help you lose weight.

1. THE WARM-UP PHASE:

This stage helps to get the blood flowing around the body while also loosening and preparing the muscles for workout. This phase will also reduce the risk of cramp and muscle injury. It is advisable to do a few stretching exercises as shown below. Each stretch should be held for approximately 30 seconds, do not force or jerk your muscles into a stretch, if it hurts, **STOP!**

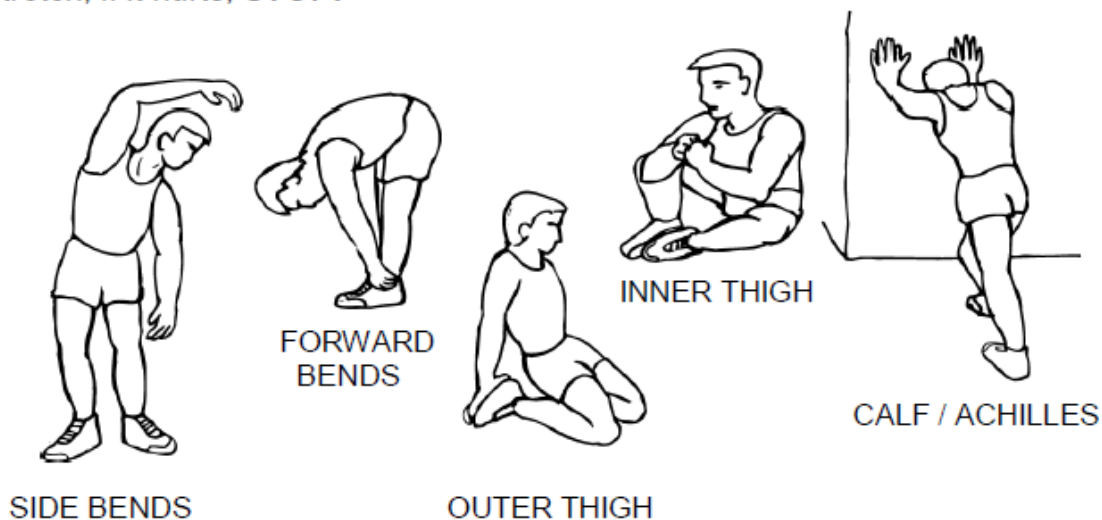

2. THE EXERCISE PHASE:

Effort is the key in this phase. After regular use, the muscles in your legs will become stronger as a result the duration & intensity of your workouts may increase based on your body's tolerance to physical activity, when increasing physical activity it is very important to maintain a steady tempo throughout. The rate of work should be sufficient enough to raise your heart beat into the target zone shown on the graph below.

Exercise Instructions

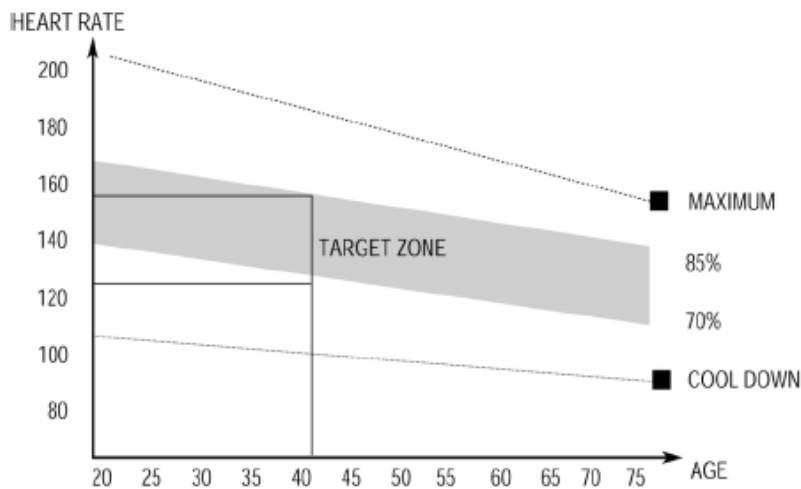

This stage should last a minimum of 12 minutes though most people start at about 15-20 minutes.

Physical activity during this stage should last for a minimum of 12 minutes, although for most people it will take about 15-20 minutes for their heart rate to reach the target zone.

3. THE COOL-DOWN PHASE:

This stage is to let your Cardio-vascular System and muscles wind down. This is a repeat of the warm up exercise e.g. reduce your tempo, continue for approximately 5 minutes. The stretching exercises should now be repeated, again remembering not to force or jerk your muscles into the stretch.

As you get fitter you may need to train longer and harder. It is advisable to train at least three times a week, and if possible space your workouts evenly throughout the week.

MUSCLE TONING:

To tone muscle while using the (ASUNA Indoor Cycling Bike) you will need to set the resistance level to high, this will increase the strain on leg muscles which will result in shorter training sessions, as the work load being increased will decrease the time required for the muscles to obtain an adequate workout. If you're also trying to improve your fitness, you'll need to alter your training program. You should train as normal during the warm up and cool down phases, but towards the end of the exercise phase the resistance should be increased in order to make your legs work harder than normal. You may have to reduce your speed to keep your heart rate in the target zone.

WEIGHT LOSS:

The most important factor here is the amount of effort you put in, the harder and longer you work the more calories you can burn. Effectively this is the same as if you were training to improve your fitness, the difference is the goal.