

- SAFETY - FIRST AND FOREMOST

FIREARMS ARE DANGEROUS WEAPONS, WHICH CAN CAUSE SERIOUS INJURY OR DEATH. WHEN USING ANY FIREARM, SAFETY MUST BE YOUR FIRST AND CONSTANT CONCERN.

READ AND UNDERSTAND THE FOLLOWING SAFETY RULES

KNOW YOUR FIREARM. Before assembling or using your Weatherby® semi-auto shotgun, read and understand the instructions and safety warnings contained in this Owner's Manual in order to learn how to use the firearm safely and correctly.

ALWAYS TREAT YOUR FIREARM AS IF IT WERE LOADED. Use the manual safety button as outlined in this manual. *Never move the safety to "FIRE" until **YOU** are ready to fire.*

KEEP THE MUZZLE POINTED IN A SAFE DIRECTION. The safe direction may be "up" on some occasions, and "down" on others. Never point the muzzle toward anything not intended as a target.

USE ONLY THE CORRECT AMMUNITION FOR YOUR FIREARM. Be sure to use only the correct gauge and length ammunition for your Weatherby® SEMI-AUTO SHOTGUN shotgun as stamped on the left side of the barrel.

ALWAYS UNLOAD YOUR FIREARM WHEN NOT SHOOTING. Never transport or store a loaded firearm in a vehicle or building. Unload your firearm before climbing a fence or obstruction, or entering a slippery area.

MAINTAIN YOUR FIREARM. Keep the barrel clean and free of obstructions. Clean your firearm regularly and have it inspected periodically to make sure it is mechanically correct and functioning properly. Worn or damaged parts can be dangerous.

DO NOT MAKE ADJUSTMENTS. Never make changes or alterations to your firearm. Use only Weatherby® parts. Do not make any adjustments to the trigger, or change the shape or size of the sear or other parts. Repair should be performed by a Weatherby® Authorized Service Center.

MAKE YOURSELF SAFE. Always wear shooting glasses. When target shooting or plinking, use ear protection also. If your firearm is equipped with a muzzle brake or is "ported", wear ear protection at all times. Never drink alcoholic beverages before or during shooting.

REMEMBER - FIREARMS SAFETY DEPENDS ON YOU!!

INDEX

• Introduction	Page 1
• Safety - First and Foremost	Page 2
• Index	Page 3
• General Overview	Page 5
• Manual Safety Operation	Page 6
• Ammunition	Page 7
• Multi-Choke [™] Tubes	Page 8
· Removing Choke Tubes	Page 8
· Installing Choke Tubes	Page 8
· Tightening Choke Tubes	Page 9
• Initial Assembly Instructions	Page 10
· Removing Forearm from Receiver Assembly	Page 10
· Assembling Barrel to Receiver	Page 10
· Assembling Forearm to Receiver Assembly	Page 11
• Operating Instructions	Page 12
· Opening the Bolt	Page 12
· Checking for and Clearing Bore Obstructions	Page 12
· To Check the barrel for Obstructions	Page 12
· Cleaning a Bore Obstruction	Page 13
· Closing the Bolt	Page 13
· Loading the Shotgun	Page 13
· Firing the Shotgun	Page 15
· Unloading the Shotgun	Page 16
• Disassembly Instructions	Page 16
· Disassembly of Barrel from Receiver	Page 16
· Disassembly of Trigger Assembly from Receiver	Page 16
· Disassembly of Bolt from Receiver	Page 17
· Removal of Choke Tubes	Page 17
• Cleaning Your Weatherby® semi-auto shotgun	Page 18
· Cleaning the Bore	Page 18
· Cleaning the Outside of the Barrel	Page 19
· Cleaning Choke Tubes	Page 19
· Cleaning the Receiver	Page 19
· Cleaning the Bolt	Page 19
· Cleaning the Slide and Carrier	Page 20
· Cleaning the Magazine	Page 20
· Cleaning the Trigger Assembly	Page 20
· Cleaning the Piston	Page 20
· Cleaning the Forearm and Buttstock	Page 20
· Rust Prevention and Removal	Page 20

• Assembly of Weatherby® semi-auto shotgun	Page 21
· Assembly of Bolt to Receiver	Page 21
· Assembly of Trigger Assembly to Receiver	Page 21
· Assembly of Piston to Magazine Tube	Page 21
· Assembly of Barrel to Receiver	Page 21
· Assembly of Forearm to Receiver	Page 21
• Storing Your Shotgun	Page 22
• Suggestions for Getting Top Performance from Your Weatherby® semi-auto shotgun	Page 22
• Exploded View Diagram (complete gun)	Page 23
• Exploded View Diagram (bolt assembly)	Page 24
• Exploded View Diagram (trigger assembly)	Page 25
• Parts Listing	Page 26
• Weatherby® Service Policy	Page 27
• Ten Commandments of Firearms Safety	Page 28
• Exercise Extreme Caution	Page 28

WEATHERBY® SEMI-AUTOMATIC SHOTGUNS

The Weatherby® semi-auto shotgun is a gas operated semi-automatic shotgun capable of feeding and firing both target and hunting loads up to 3 inch.

With proper care as outlined in this manual, your Weatherby® semi-auto shotgun should give you many years of dependable use and shooting pleasure.

The picture below shows the main parts of the Weatherby® semi-auto shotgun. Please refer to it when reading this manual. It will aid in understanding the terminology.

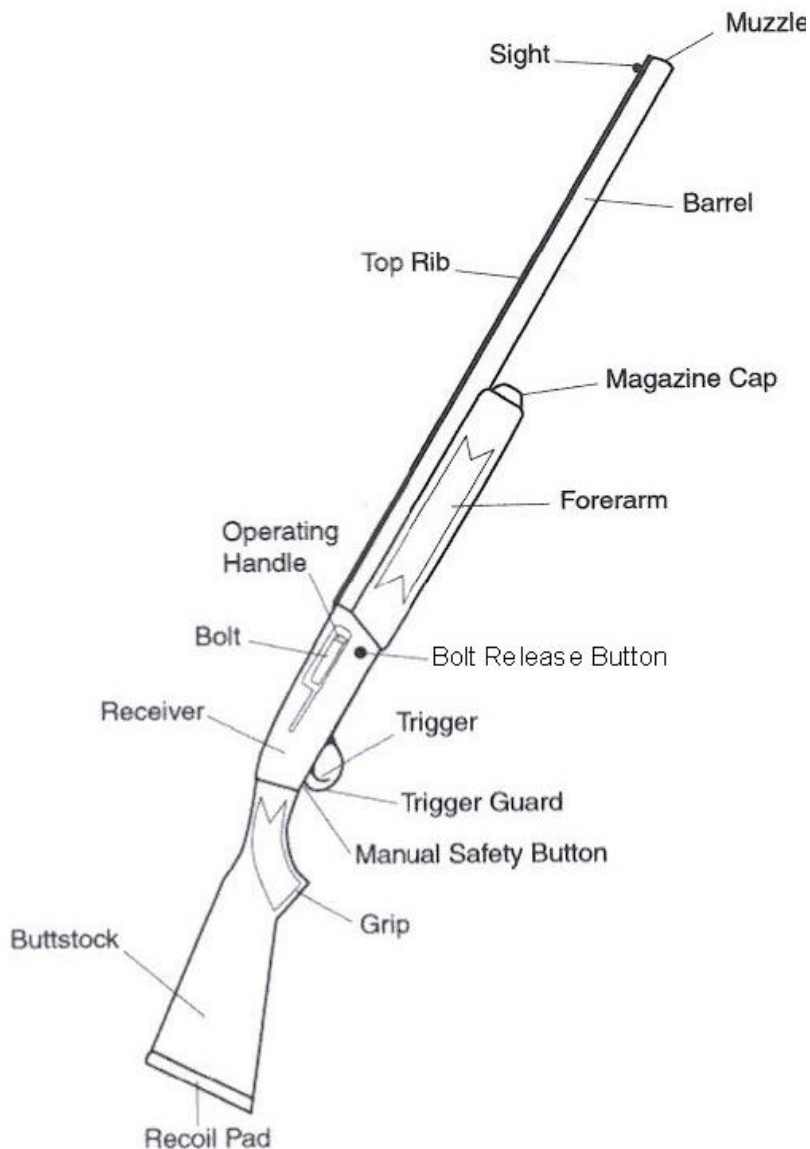

Fig. 1

LEAD WARNING!
DISCHARGING FIREARMS IN POORLY VENTILATED AREAS, CLEANING FIREARMS, OR HANDLING AMMUNITION MAY RESULT IN EXPOSURE TO LEAD OR OTHER SUBSTANCES KNOWN TO CAUSE BIRTH DEFECTS, REPRODUCTIVE HARM AND OTHER SERIOUS PHYSICAL INJURY. HAVE ADEQUATE VENTILATION AT ALL TIMES. WASH HANDS THOROUGHLY AFTER EXPOSURE.

MANUAL SAFETY OPERATION

The manual safety on the Weatherby® semi-automatic shotgun is a button-type safety located on the rear of the trigger guard. When in proper condition and correctly engaged in the "SAFE" position, the manual safety blocks the trigger and prevents accidental discharge under normal usage.

WARNING!!

Never depend on any mechanical safety mechanism or device to prevent the dangers of careless handling or pointing a firearm in an unsafe direction.

When manipulating the manual safety, keep all fingers outside the trigger guard. The shotgun will fire if the trigger is pulled when the safety is not in the "SAFE" position.

The safety should always be in the "SAFE" position except when the shotgun is intended to be fired.

Never Pull the trigger when the safety is in the "SAFE" position.

The manual safety can be moved between the "SAFE" and "FIRE" positions at any time, regardless of whether or not the shotgun is loaded or cocked. ***To minimize the possibility of accidental discharge, it is strongly recommended that the safety always be placed in the "SAFE" position except when the shotgun is intended to be fired.***

To engage the manual safety, push the safety button all the way through the trigger guard from left to right with your thumb until it stops and stays in place in the "SAFE" position. Fig. 2

To disengage the manual safety, push the safety button through the trigger guard from right to left with your thumb until it stops and stays in place in the "FIRE" position (a red mark will be visible on the safety button to the left of the trigger guard.)

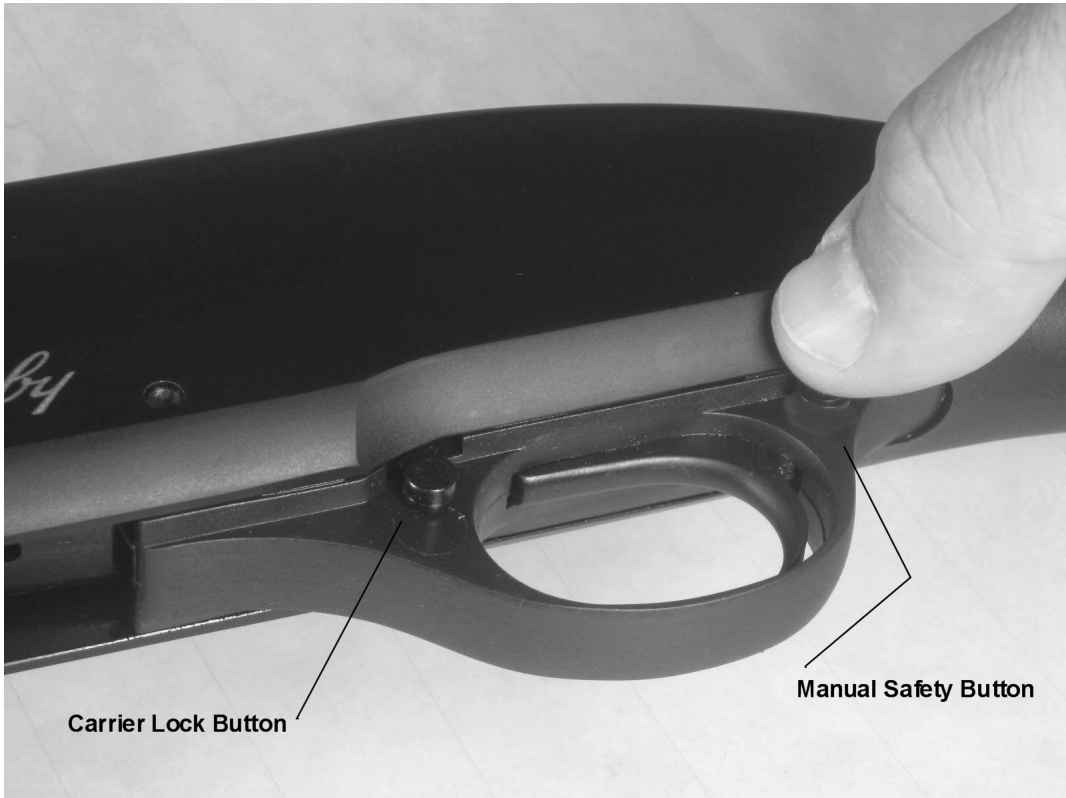

Fig. 2

AMMUNITION

Weatherby® semi-automatic shotguns are chambered only for 12 and 20 ga. shells in 2¾ and 3 inch lengths, for which factory-loaded ammunition manufactured in accordance with U.S. industry standards is commercially available. Barrels marked for 3" shot shells can be safely used for both 2¾" and 3" shot shells. Barrels marked for 2¾" can be safely used for 2¾" shot shells only.

Chokes are crafted from high grade steel and are certified for steel shot through modified choke constrictions.

Exercise care to assure that you are using only the correct ammunition for your shotgun. Always make certain that the gauge indicated on the shot shell headstamp matches the gauge marked on the barrel of your shotgun, and that the length of the shell is correct for your shotgun.

WARNING!!

Use of incorrect or overloaded ammunition can result in death or serious injury and damage to your firearm due to excessive pressure. Even the strongest firearm can be "blown up" by excessive pressure. Use only factory-loaded ammunition of the correct gauge and length for your shotgun as marked on the shotgun's barrel.

The accidental chambering and discharge of shells of the wrong gauge or length can result in damage to your gun and possible injury to the shooter. Carry only the proper gauge ammunition with you when shooting. A 20 ga. shell will enter a 12 ga. chamber far enough to leave room for a 12 ga. shell behind it. A damaged gun and possible injury to the shooter will result if the barrel is fired. Also, a 3½ inch shell will chamber into a 3 inch chamber, but the crimp will unfold into the forcing cone, causing possible unsafe pressures.

Always wear shooting glasses and hearing protectors when shooting.

AMMUNITION NOTICE

WEATHERBY, INC. SPECIFICALLY DISCLAIMS RESPONSIBILITY FOR ANY INJURY OR DAMAGE WHATSOEVER OCCURRING IN CONNECTION WITH, OR AS A RESULT OF, THE USE OF FAULTY, OR NON-STANDARD, OR "REMANUFACTURED" OR HAND-LOADED OR RELOADED AMMUNITION, OR OF AMMUNITION OTHER THAN FOR WHICH THE FIREARM WAS ORIGINALLY CHAMBERED.

MULTI-CHOKE™ TUBES

Each new Weatherby® semi-auto shotgun (with the exception of shotguns having rifled barrels for firing slugs) is equipped with interchangeable Multi-Choke™ choke tubes and one choke tube wrench (Fig. 4). If applicable, one of the choke tubes is installed in the muzzle of the barrel, and the remaining choke tubes are packaged in the shipping box.

Weatherby® Multi-Choke™ tubes are crafted from high grade steel and are certified for steel shot through modified choke constrictions.



Fig. 4

REMOVING CHOKE TUBES

Choke tubes may be removed with the barrel disassembled from the shotgun or with the barrel assembled to the shotgun by following these simple instructions. (NOTE: If removing choke tubes with the barrel removed from the shotgun, begin from instruction no. 3.)

When removing a choke tube from a barrel assembled to the shotgun, keep the muzzle of the shotgun pointed in a safe direction, and keep your fingers out of the trigger guard and away from the trigger at all times.

1. Move the manual safety button to "SAFE" position (*refer to Manual Safety Operation, page 6*), before removing a choke tube from a barrel assembled to a shotgun.
2. Unload the shotgun (*refer to Unloading the Shotgun, page 16*).
3. Insert the stepped end of the choke tube wrench into the muzzle of the barrel and into the notches in the muzzle end of the choke tube.
4. Turn the choke tube counter-clockwise with the wrench until it emerges from the muzzle sufficiently to grasp with your fingers.
5. Continue turning the choke tube counter-clockwise with your fingers until it is free to be removed from

the muzzle.

INSTALLING CHOKE TUBES

Choke tubes may be installed into a barrel disassembled from the shotgun or with the barrel assembled to the shotgun, by following these simple instructions. NOTE: If installing choke tubes with the barrel removed from the shotgun, begin from instruction no. 3.

When installing a choke tube into a barrel assembled to the shotgun, keep the muzzle of the shotgun pointed in a safe direction, and keep your fingers out of the trigger guard and away from the trigger at all times.

1. Move the manual safety button to the "SAFE" position (*refer to Manual Safety Operation, page 6*), before installing a choke tube into a barrel assembled to a shotgun.
2. Unload the shotgun (*refer to Unloading the shotgun, page 16*).
3. Insert the threaded end of the choke tube into the muzzle of the barrel, and screw it into the barrel as far as possible with your fingers, turning it in a clock-wise direction.
4. Insert the stepped end of the choke tube wrench into the notches in the muzzle end of the choke tube, and continue turning clock-wise until the choke tube is seated, tightening snugly.

CAUTION: *To prevent damage to barrel or choke tube threads, do not over-tighten.*

TIGHTENING CHOKE TUBES

Choke tubes may loosen with repeated recoil, which may result in changes in point of impact or damage to choke tube or barrel threads with extended use. Check and tighten choke tubes frequently – before, after and during shooting – as follows:

Keep the muzzle of the shotgun pointed in a safe direction, and keep your fingers out of the trigger guard and away from the trigger at all times.

1. Move the manual safety button to the "SAFE" position (*refer to Manual Safety Operation, page 6*).
2. Unload the shotgun (*refer to Unloading the Shotgun, page 16*).
3. Insert the stepped end of the choke tube wrench into the notches in muzzle end of choke tube, and tighten the choke tube snugly, turning clock-wise.

CAUTION: *To prevent damage to barrel or choke tube threads, do not over-tighten.*

WARNING!! Loose choke tubes may cause bore obstructions due to "shaving" shot or preventing a wad from exiting the muzzle, which could result in injury or death to the shooter or bystanders and damage to the shotgun. Tighten choke tubes frequently -- before, during and after shooting.

INITIAL ASSEMBLY INSTRUCTIONS

REMOVING FOREARM FROM RECEIVER ASSEMBLY

New Weatherby® semi-automatic shotguns are packaged in "take down" condition – the barrel separated from the receiver assembly, with the forearm attached to the receiver assembly, in the shipping carton in which the shotgun is received by the dealer. The shotgun may also have been stored in "take down" condition. Before assembly of the shotgun, the forearm must be removed from the receiver assembly.

Remove the forearm from the receiver assembly as follows:

1. Grasp the magazine cap with one hand while holding the buttstock or receiver with the other hand.
2. Remove the magazine cap by turning it counter-clockwise until it separates from the magazine tube. Fig. 5
3. Grasp the forearm and slide it forward, away from the receiver, until it separates from the magazine tube. Fig. 6



Fig. 5

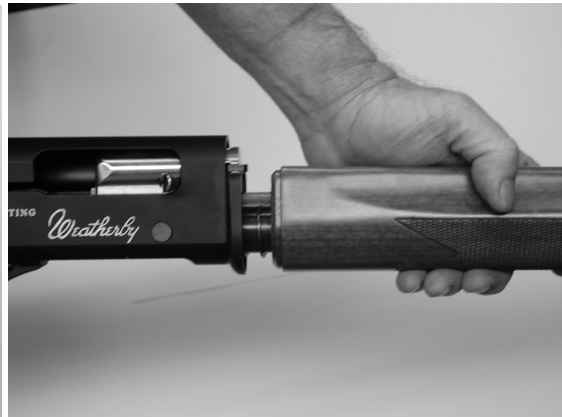

Fig. 6

ASSEMBLING BARREL TO RECEIVER

Keep the muzzle of the shotgun pointed in a safe direction, and keep your fingers out of the trigger guard and away from the trigger at all times.

1. Visually examine the barrel to make sure there is no shot shell in the chamber or obstruction in the bore, and all surfaces are free of dirt and excess oil.
2. Remove the forearm from the receiver assembly (*refer to Removing Forearm from Receiver Assembly, page 10*).
3. Apply a very light coat of gun oil to the "O" ring inside the gas port cylinder (refer to Fig 7). This oil will help with the assembly, preventing wear to the "O" ring.
4. Grasp the receiver and buttstock assembly with one hand, while grasping the barrel with your other hand.
5. With the bolt in the closed (fully forward) position, align the barrel shank on chamber end of the barrel with the receiver ring (refer to Fig.8) and the barrel gas port cylinder with the magazine tube.
6. Insert the barrel shank into the receiver until the barrel stops against the receiver, with the gas port cylinder fitting over the magazine tube.

7. Pull the bolt handle half way back while applying rearward pressure on the barrel to fully seat the barrel into the receiver.
8. Place the piston on the magazine tube (*refer to Assembly of piston to magazine tube, page 21*).
9. Assemble the forearm to the receiver assembly (*refer to Assembling Forearm to Receiver Assembly, page 11*).



Fig. 7



Fig. 8

WARNING!! If ammunition is present in the barrel's chamber, the receiver loading port or the magazine, the shotgun will be loaded, cocked and ready to fire by releasing the bolt and pulling the trigger with the safety "Off" (in the "FIRE" position).

ASSEMBLING FOREARM TO RECEIVER ASSEMBLY

The forearm may be assembled to the receiver assembly with the barrel installed, or without the barrel installed for storage in "take-down" condition. NOTE: If installing the forearm with the barrel removed from the shotgun, begin from instruction no. 4.

When assembling the forearm to the receiver assembly with the barrel also installed, keep the muzzle of the shotgun pointed in a safe direction, and keep your fingers out of the trigger guard and away from the trigger at all times.

1. Move the manual safety button to the "SAFE" position (*refer to Manual Safety Operation, page 6*).
2. Unload the shotgun (*refer to Unloading the Shotgun, page 16*).
3. Align the forearm with the barrel in front of the magazine tube.
4. Slide the forearm rearward over the magazine tube until the magazine tube protrudes through the front of the forearm and the forearm is seated against the forearm latch. The forearm must set completely against the forearm latch to prevent breakage. (Ref fig. 9 & 10)
5. While applying rearward pressure on the forearm, screw the magazine cap onto the magazine tube until tight.

WARNING!! If the barrel is also installed and ammunition is present in the barrel's chamber, the receiver loading port or the magazine, the shotgun will be loaded, cocked and ready to fire by releasing the bolt and pulling the trigger with the safety "Off" (in the "FIRE" position).



Fig. 9



Fig. 10

OPERATING INSTRUCTIONS

OPENING THE BOLT

Keep the muzzle of the shotgun pointed in a safe direction, and keep your fingers out of the trigger guard and away from the trigger at all times.

1. Move the manual safety button to the "SAFE" position (*refer to Manual Safety Operation, page 6*).
2. Unload the gun (*refer to Unloading the Shotgun, page 16*).
3. Lock the carrier by pressing the carrier lock button. (*refer to Fig. 2*)
Note: The bolt only locks open when the carrier is locked and no ammunition is in the magazine.
4. While resting the butt pad against your thigh, grasp the shotgun forearm firmly with one hand.
5. With the other hand grasp the operating handle and pull the bolt rearward until the bolt locks into the open position.

CHECKING FOR AND CLEARING BORE OBSTRUCTIONS

The barrel of your shotgun should always be checked for obstructions before assembly, before loading and **immediately** following any occurrence in the field which might result in mud, dirt or other debris entering the bore.

WARNING!! Never attempt to check for or clear a bore obstruction by loading a shot shell into the chamber of the barrel and firing! If there is a bore obstruction this will cause excessive pressures which may result in death or serious injury and damage to your shotgun.

TO CHECK THE BARREL FOR OBSTRUCTIONS

Keep the muzzle of the shotgun pointed in a safe direction, and keep your fingers out of the trigger guard and away from the trigger at all times.

1. Move the manual safety button to the "SAFE" position (*refer to Manual Safety Operation, page 6*).

2. Unload the shotgun (*refer to Unload the Shotgun, page 16*).
3. Disassemble barrel from receiver (*refer to Disassembly of Barrel from Receiver, page 16*).
4. Visually check the bore for obstructions by looking through the barrel from the breech end through the muzzle.

CLEARING A BORE OBSTRUCTION

1. Push a shotgun bore cleaning tool through the bore from the breech end until the end of tool exits the muzzle.
2. If the obstruction cannot be easily cleared, contact a Weatherby Authorized Service Center or your local gunsmith.

CLOSING THE BOLT

Keep the muzzle of the shotgun pointed in a safe direction, and keep your fingers out of the trigger guard and away from the trigger at all times.

1. Move the manual safety button to the "SAFE" position (*refer to Manual Safety Operation, page 6*).
2. Hold the shotgun with one hand grasping the forearm firmly.
3. With the other hand press the bolt release button to permit the bolt to move forward. (**Caution: Do not depress the bolt release button without a barrel installed; this will cause damage to the receiver.**)

CAUTION: To avoid injury, keep hands and fingers away from the loading port when releasing the bolt from the locked position.)

WARNING!! If a shot shell is in the receiver loading port when the bolt release button is depressed and the manual safety is not in the "SAFE" position, the shotgun is now ready to fire. Do not touch the trigger until YOU are ready to fire.

4. Visually check the manual safety button to make certain it is in the "SAFE" position (*refer to Manual Safety Operation, page 6*).

LOADING THE SHOTGUN

WARNING!!

Use of incorrect or overloaded ammunition can result in death or serious injury and damage to your firearm due to excessive pressure. Even the strongest firearm can be "blown up" by excessive pressure. Use only factory-loaded ammunition of the correct gauge and length for your shotgun as marked on the shotgun's barrel.

The accidental chambering and discharge of shells of the wrong gauge can result in damage to your gun and possible injury to the shooter. Carry only the proper gauge ammunition with you when shooting. A 20 ga. shell will enter a 12 ga. chamber far enough to leave room for a 12 ga. shell behind it. A damaged gun and possible injury to the shooter will result if the barrel is fired. Also, a 3½-inch shell will chamber into a 3-inch chamber, but the crimp will unfold into the forcing cone, causing possible unsafe pressures.

Always wear shooting glasses and hearing protectors when shooting.

AMMUNITION NOTICE

WEATHERBY, INC. SPECIFICALLY DISCLAIMS RESPONSIBILITY FOR ANY INJURY OR DAMAGE WHATSOEVER OCCURRING IN CONNECTION WITH, OR AS A RESULT OF, THE USE OF FAULTY, OR NON-STANDARD, OR "REMANUFACTURED" OR HAND-LOADED OR RELOADED AMMUNITION, OR OF AMMUNITION OTHER THAN FOR WHICH THE FIREARM WAS ORIGINALLY CHAMBERED.

To Load the Magazine

Keep the muzzle of the shotgun pointed in a safe direction, and keep your fingers out of the trigger guard and away from the trigger at all times.

1. Move the manual safety button to the "SAFE" position (*refer to Manual Safety Operation, page 6*).
2. Open the bolt (*refer to Opening the Bolt, Page 12*) and visually check to make sure no shell is in the receiver ejection port.
3. Close the bolt (*refer to Closing the Bolt, Page 13*).
4. Referring to Fig. 10, insert desired number of shot shells of the proper gauge/length (*refer to Ammunition, page 7*) into the magazine through the loading port by depressing the bolt release button then pushing each shell forward fully into the magazine until it is held in place by the carrier latch.



Fig. 10

To Feed a Shell from the Magazine into the Chamber

Keep the muzzle of the shotgun pointed in a safe direction, and keep your fingers out of the trigger guard and away from the trigger at all times.

1. Visually check the manual safety button to make sure it is in the "SAFE" position (*refer to Manual Safety Operation, page 6*).
2. Press the carrier lock button, to release a shell onto the carrier from the magazine and lock the carrier.
3. Cycle the bolt to permit feeding of the shell from the carrier into the chamber.

WARNING!! If the manual safety is not in the "SAFE" position, the shotgun is now ready to fire. Do not touch the trigger until YOU are ready to fire.

To Single-load the Chamber without Shells in the Magazine.

Keep the muzzle of the shotgun pointed in a safe direction, and keep your fingers out of the trigger guard and away from the trigger at all times.

1. Move the manual safety button to the "SAFE" position (*refer to Manual Safety Operation, page 6*).
2. Open the bolt of the shotgun (*refer to Opening the Bolt, Page 12*).
3. Drop a shot shell of the proper size (*refer to Ammunition, page 7*) load directly into the ejection port, with the crimped end forward.
4. Press the bolt release button (*refer to Closing the Bolt, Page 13*) to allow the bolt to close and feed the shell into the chamber.

WARNING!! If the manual safety is not in the "SAFE" position, the shotgun is now ready to fire. Do not touch the trigger until YOU are ready to fire.

To single-load the chamber with shells in the magazine.

Keep the muzzle of the shotgun pointed in a safe direction, and keep your fingers out of the trigger guard and away from the trigger at all times.

1. Move the manual safety button to the "SAFE" position (*refer to Manual Safety Operation, page 6*).
2. Open and hold the bolt of the shotgun back with one hand while dropping one shot shell of the proper size (*refer to Ammunition, page 7*) directly into the receiver loading port, with the crimped end forward.
3. Release the bolt handle to allow the bolt to close and feed the shell into the chamber.

WARNING!! If the manual safety is not in the "SAFE" position, the shotgun is now ready to fire. Do not touch the trigger until YOU are ready to fire.

FIRING THE SHOTGUN

Pulling the trigger fires the shotgun when a shot shell is in the chamber.

1. With a shot shell in the chamber of the barrel, and **keeping the muzzle of the shotgun pointed in a safe direction and your fingers out of the trigger guard and away from the trigger**, move the manual safety button to the "FIRE" position (*refer to Manual Safety Operation, page 6*).
2. Hold the recoil pad snugly to your shoulder and carefully point the muzzle of the shotgun at your intended target.
3. Squeeze (pull) the trigger with steadily increasing pressure until the shotgun fires.

WARNING!! Do not touch the trigger until you are actually ready to fire the shotgun, or an unintended discharge may occur, possibly resulting in death or injury to a bystander, or damage to an unintended target.

CAUTION: *If another shot shell is in the magazine it will automatically be fed into the chamber and will fire upon the next pull of the trigger.*

4. Unless an immediate second shot is intended, immediately:
 - a. Remove your finger from the trigger;
 - b. Unload the shotgun (*refer to Unloading the shotgun, page 16*).

UNLOADING THE SHOTGUN

ALWAYS UNLOAD YOUR SHOTGUN IMMEDIATELY AFTER YOU FINISH SHOOTING.

Keep the muzzle of the shotgun pointed in a safe direction, and keep your fingers out of the trigger guard and away from the trigger at all times.

1. Move the manual safety button to the "SAFE" position (*refer to Manual Safety Operation, page 6*).
2. To unload a shell from the chamber, pull the operating handle rearward to extract the shell.
3. To unload the magazine, lock the carrier by pressing the carrier lock button (located on the left side next to the trigger guard).
4. Cycle the bolt to feed the next shell into the chamber.
5. Press the carrier lock button again. Cycle the bolt to extract the shell from the chamber and feed the next shell into the chamber.
6. Repeat step 5 until the magazine is empty and the bolt locks open.
7. Visually confirm that there are no shot shells remaining in the magazine or chamber.

DISSEMBLY INSTRUCTIONS

DISSEMBLY OF BARREL FROM RECEIVER

Keep the muzzle of the shotgun pointed in a safe direction, and your keep fingers out of the trigger guard and away from the trigger at all times.

1. Unload the shotgun (*refer to Unloading the Shotgun, page 16*).
2. Close the bolt by depressing the bolt release button.
3. Unscrew the magazine cap by turning it in a counter clock-wise direction until easily detached.
4. Remove the forearm by sliding it forward (toward the muzzle), until clear of the magazine tube.
5. Remove the barrel by grasping firmly and pushing forward (in the direction of the muzzle) until the barrel tang is clear of the receiver ring.

DISSEMBLY OF TRIGGER ASSEMBLY FROM RECEIVER

Caution: Make sure the hammer is in the cocked position prior to removing the trigger assembly from the receiver. This is achieved by pulling the bolt to the rear then releasing it. Have the safety in the "ON" ("SAFE") position while cleaning the trigger assembly. Do not pull the trigger while the trigger assembly is outside of the receiver.

1. Unload the Shotgun (*refer to Unloading the Shotgun page 16*) and disassemble the barrel from the receiver. (*refer to Disassembly of Barrel from Receiver, page 16*)
2. Move the manual safety button to the "SAFE" position (*refer to Manual Safety Operation, page 6*).
3. Pull bolt to rear then ease it forward to make sure the hammer is cocked. (**Caution: do not close a locked open bolt by depressing the bolt release button without a barrel installed; this will cause damage to the receiver**).
4. With a hammer and punch push the receiver pin through the receiver (*refer to Fig. 12*) until the pin is out far enough to be grasped by hand, and remove the pin from the receiver.
5. Using one or two fingers push the trigger assembly forward approximately ¼", then pull the trigger assembly straight out from the receiver.

DISASSEMBLY OF BOLT FROM RECEIVER

1. Remove forearm (*refer to Removing Forearm from Receiver Assembly, page 10*) and barrel (*refer to Disassembly of Barrel from Receiver, page 16*).
2. Remove the gas piston from magazine tube by sliding it forward until it is free from tube.
3. Push the slide assembly approximately 1" rearward (towards the buttstock), and hold.
4. Remove the bolt handle by grasping with fingers and pulling outward (see Fig. 13 below), making sure to hold back the slide from moving forward.



Fig. 12



Fig. 13

5. Move the slide along the magazine tube until the bolt is outside of the receiver. The bolt will then detach from the slide.

Note: If the piston is removed or comes off the magazine tube, make sure it is placed back onto the magazine tube in the proper direction. The piston will work only if the large outside diameter of the piston is placed onto the magazine tube first.

REMOVAL OF CHOKE TUBES

Remove Multi-Choke™ choke tubes as describe under Removing Choke Tubes, Page 8.

Further disassembly of the shotgun is not recommended. If further disassembly is required, contact a Weatherby Authorized Service Center or your local gunsmith.

CLEANING YOUR WEATHERBY® SEMI-AUTO SHOTGUN

Any firearm requires regular cleaning and periodic maintenance. To assure safe and reliable functioning of your Weatherby® semi-auto shotgun, it is very important that you clean it immediately after each use, and periodically during extended storage periods, to remove powder residue, dirt, dust and excess lubricant, and to prevent rust. During cleaning, inspect components to determine whether they are in proper working order.

A basic cleaning kit consists of proper-sized cleaning rod, bore brush(es) and patches; gun cleaning solvent, gun lubricant, and lint-free cloths. The cleaning rod must have a tip with a slot into which patches can be inserted. Additionally, tooth brushes, cotton swabs and pipe cleaners are very handy tools for cleaning away dirt in hard to reach places.

To properly clean your shotgun, it must first be disassembled (*refer to Disassembly Instructions, page 18*), the parts and components cleaned as discussed below, then reassembled (*refer to Assembly Instructions, page 23*).

CAUTION: *Apply solvents and lubricants properly and sparingly. Do not spray or apply directly on ammunition. Solvents and lubricants may affect the propellant, causing it not to ignite, but the energy from the primer may be sufficient to propel the propellant, wad and shot column into the bore of the barrel, causing an obstruction, and resulting in damage to the shotgun and serious injury to the shooter and bystanders upon firing a subsequent shot shell.*

CLEANING THE BORE

1. Apply gun cleaning solvent to a bore cleaning brush of the proper size attached to the cleaning rod.
2. Push the brush all the way through the barrel bore several times from the chamber end.
3. Insert the brush into the muzzle of the barrel only far enough to encounter the threads for the choke tube, and twist it several times.
4. With a clean patch inserted in the tip attached to the cleaning rod, push the rod all the way through the barrel bore from the chamber end until the cloth emerges from the muzzle. Remove the dirty patch and withdraw the rod.
5. Repeat step 4 as many times as needed until the patch is clean as it emerges from the muzzle.
6. Using a clean patch or lint-free cloth wrapped around the tip of your finger or similarly shaped object, remove all solvent from the muzzle and from the choke tube threads inside the barrel bore.
7. Insert a patch saturated with gun lubricant into the cleaning rod tip and push it through the bore from the chamber end. Remove the patch and withdraw the rod.
8. Insert a dry, clean patch into the cleaning rod tip and push it through the bore from the chamber end, to remove excess lubricant. Remove the patch and withdraw the rod.
9. Using a clean patch or lint-free cloth wrapped around the tip of your finger or similarly shaped object, apply a light coat of gun lubricant to the choke tube threads and muzzle of the barrel bore.

WARNING!! Excess lubrication in the bore or chamber of any firearm may create excessive chamber pressures or a partial bore obstruction, resulting in possible damage to the firearm and serious injury to the shooter and bystanders upon firing. BE SURE ALL EXCESS LUBRICANT HAS BEEN REMOVED.

CLEANING THE OUTSIDE OF THE BARREL

1. Using a patch or clean cloth saturated with cleaning solvent, wipe down all accessible surfaces of the barrel, rib and barrel ring. (A clean tooth brush may be handy for cleaning the corners and recesses of the rib and barrel ring.)
2. With a clean, dry, lint-free cloth, remove all cleaning solvent.
3. Using a patch or clean cloth, apply a light coat of gun lubricant to the outside surfaces of the barrel, rib and barrel ring, being careful to remove any excess lubricant.

CLEANING CHOKE TUBES

1. Apply gun cleaning solvent to a bore cleaning brush of the proper size attached to the cleaning rod.
2. Push the brush all the way through the choke tube several times.
3. With a clean patch inserted in the tip attached to the cleaning rod, push the rod all the way through the choke tube until the patch emerges from the other end. Remove the dirty patch and withdraw the rod.
4. Repeat step 3 as many times as needed until the patch is clean as it emerges from the choke tube.
5. Insert a patch saturated with gun lubricant into the cleaning rod tip and push it through the choke tube. Remove the patch and withdraw the rod.
6. Insert a dry, clean patch into the cleaning rod tip and push it through the choke tube to remove excess lubricant. Remove the patch and withdraw the rod.
7. Using a patch or clean cloth saturated with cleaning solvent, wipe down the outside surfaces of the choke tube. (A clean tooth brush may be handy for cleaning the threads.)
8. With a clean, dry lint-free cloth, remove all cleaning solvent.
9. Using a patch or clean cloth, apply a light coat of gun lubricant to the outside surfaces of the choke tube, being careful to remove any excess lubricant.

CLEANING THE RECEIVER

1. Using a small lint-free cloth, clean the inside and outside of the receiver with gun-cleaning solvent and dry thoroughly with a clean cloth.
2. With a clean cloth or patch, apply a light coat of gun lubricant to all accessible surfaces of the receiver.

CLEANING THE BOLT

1. Using a small lint-free cloth, clean the inside and outside of the bolt assembly with gun-cleaning solvent; and dry thoroughly with a clean cloth. (A clean toothbrush may be handy for cleaning the recesses of the bolt)
2. With a clean cloth or patch, apply a light coat of gun lubricant to all accessible surfaces of the bolt.

CLEANING THE SLIDE AND CARRIER

1. Using a small lint-free cloth, clean the inside and outside of the slide and carrier with gun-cleaning solvent; and dry thoroughly with a clean cloth. (A clean tooth brush may be handy for cleaning some the areas of the slide and carrier)
2. With a clean cloth or patch, apply a light coat of gun lubricant to all accessible surfaces of the slide and carrier.

CLEANING THE MAGAZINE

1. Using a lint-free cloth, clean the outside of the magazine tube with gun-cleaning solvent; and dry thoroughly with a clean cloth.
2. With a clean cloth or patch, apply a light coat of gun lubricant to outside surface of the magazine tube.

CLEANING THE TRIGGER ASSEMBLY

Caution: Make sure the hammer is in the cocked position prior to removing the trigger assembly from the receiver. This is achieved by pulling the bolt to the rear then releasing it. Make sure the safety is in the "ON" ("SAFE") position while cleaning the trigger assembly. Do not pull the trigger while the trigger assembly is outside of the receiver.

1. Using a small lint-free cloth, clean the outside of the trigger assembly and with a clean tooth brush, brush the top surface of the trigger assembly mechanism with gun-cleaning solvent; and dry thoroughly with a clean cloth.
2. With a clean cloth or patch, apply a light coat of gun lubricant to all accessible surfaces of the slide and carrier.

CLEANING THE PISTON

1. Using a small lint-free cloth and clean tooth brush, clean the inside and outside of the piston with gun-cleaning solvent; and dry thoroughly with a clean cloth.
2. With a clean cloth or patch, apply a light coat of gun lubricant to all accessible surfaces of the piston.

CLEANING THE FOREARM AND BUTTSTOCK

Usually, wiping the forearm and butt stock with a clean, dry cloth or a silicon cloth is all that is necessary. If you have been hunting or shooting in wet weather, allow the butt stock to dry thoroughly before storage.

RUST PREVENTION AND REMOVAL

During normal maintenance, after a thorough cleaning, allow 2-3 hours at room temperature, for all metal parts to dry completely. Then apply a liberal amount of high grade Gun Oil to all metal parts, wiping off any excess with a clean dry cloth. If rusting does occur it may only be surface rust due to excessive moisture. You may be able to remove it by using a plastic bristle gun cleaning brush and gun cleaning solvent. If you are unable to remove rust on your shotgun, please contact a Weatherby Authorized Service Center or your local gunsmith. Immediate attention to this problem is imperative to prevent irreparable rust damage.

DO NOT ALLOW RUST TO GO UNTREATED!

ASSEMBLY OF WEATHERBY®
SEMI-AUTO SHOTGUN

ASSEMBLY OF BOLT TO RECEIVER

Note: It is recommended to assemble the bolt to the receiver with the trigger assembly removed from the receiver.

1. Assemble the bolt assembly onto the slide arm assembly.
2. Place the cylinder of the slide arm assembly over the magazine tube and move the slide toward the receiver, aligning the bolt with the receiver as the bolt enters the receiver opening.
3. Slide the bolt into the receiver aligning the link with the recoil spring cap.
4. Once the bolt is far enough into the receiver, push the bolt handle into the bolt.

ASSEMBLY OF TRIGGER ASSEMBLY TO RECEIVER

1. While pushing and holding the bolt release button push the trigger assembly into the receiver until the trigger assembly is flush with the bottom of the receiver. Push the trigger assembly forward to seat the trigger assembly against the receiver, aligning the trigger pin hole in the trigger assembly and the receiver.
2. Press the receiver pin into the receiver until flush with the receiver side.

ASSEMBLY OF PISTON TO MAGAZINE TUBE

Note: The Weatherby® semi-auto shotgun comes with 2 pistons. By having the two different pistons the operator can switch between heavy load and light load ammunition, allowing the action to cycle correctly with different ammunition. To determine the best piston for the ammunition, it is recommended to use the heavy load piston first, and if there is a problem with the gun cycling correctly change to the light load piston.

1. Place the piston into the magazine tube by sliding the piston over the forward end of the magazine tube, making sure the large outside diameter of the piston goes onto the magazine tube first.

ASSEMBLY OF BARREL TO RECEIVER

Assemble the barrel as described under ASSEMBLING BARREL TO RECEIVER, page 10.

ASSEMBLY OF FOREARM TO RECEIVER

Assemble the forearm to the receiver as described under ASSEMBLING FOREARM TO RECEIVER ASSEMBLY, page 11.

STORING YOUR SHOTGUN

Your Weatherby® semi-auto shotgun may be stored fully assembled (*refer to Assembly Instructions, page 21*), or in "take down" condition.

If storing your shotgun fully assembled, release the pressure on the hammer spring as follows:

1. Make certain the shotgun is not loaded by following unloading procedures (*refer to Unloading the Shotgun, Page 16*).
2. Close the bolt (*refer to Closing the Bolt, page 13*)
3. **Pointing the muzzle of the shotgun in a safe direction**, pull the trigger.

Do not store your shotgun in a leather case, scabbard or foam lined gun case. Leather and foam can attract moisture and cause rusting.

For your safety, and the safety of others, store your shotgun with a lock or other safety device properly installed; and store your ammunition in a separate, locked location.

SUGGESTIONS FOR GETTING TOP PERFORMANCE FROM YOUR WEATHERBY® SEMI-AUTO SHOTGUN

1. Check and tighten choke tubes frequently – before, during and after shooting. Choke tube threads may loosen with repeated recoil, which may result in changes in point of impact or damage to choke tube or barrel threads with extended use.
2. The accuracy of any firearm can vary depending upon the brand and type of ammunition used in it. If your shotgun does not exhibit the consistent point of impact and shot pattern you expect, you should try several brands and types of ammunition, after referring to point 1, above, before concluding that it is "inaccurate".

DO NOT ALTER THE STOCK BEDDING IN ANY WAY. Once a stock has been altered, it cannot be reworked by our Service Department or a Weatherby Authorized Service Center.

3. Consult the factory before returning any product for inspection or repair.

EXPLODED VIEW DIAGRAM

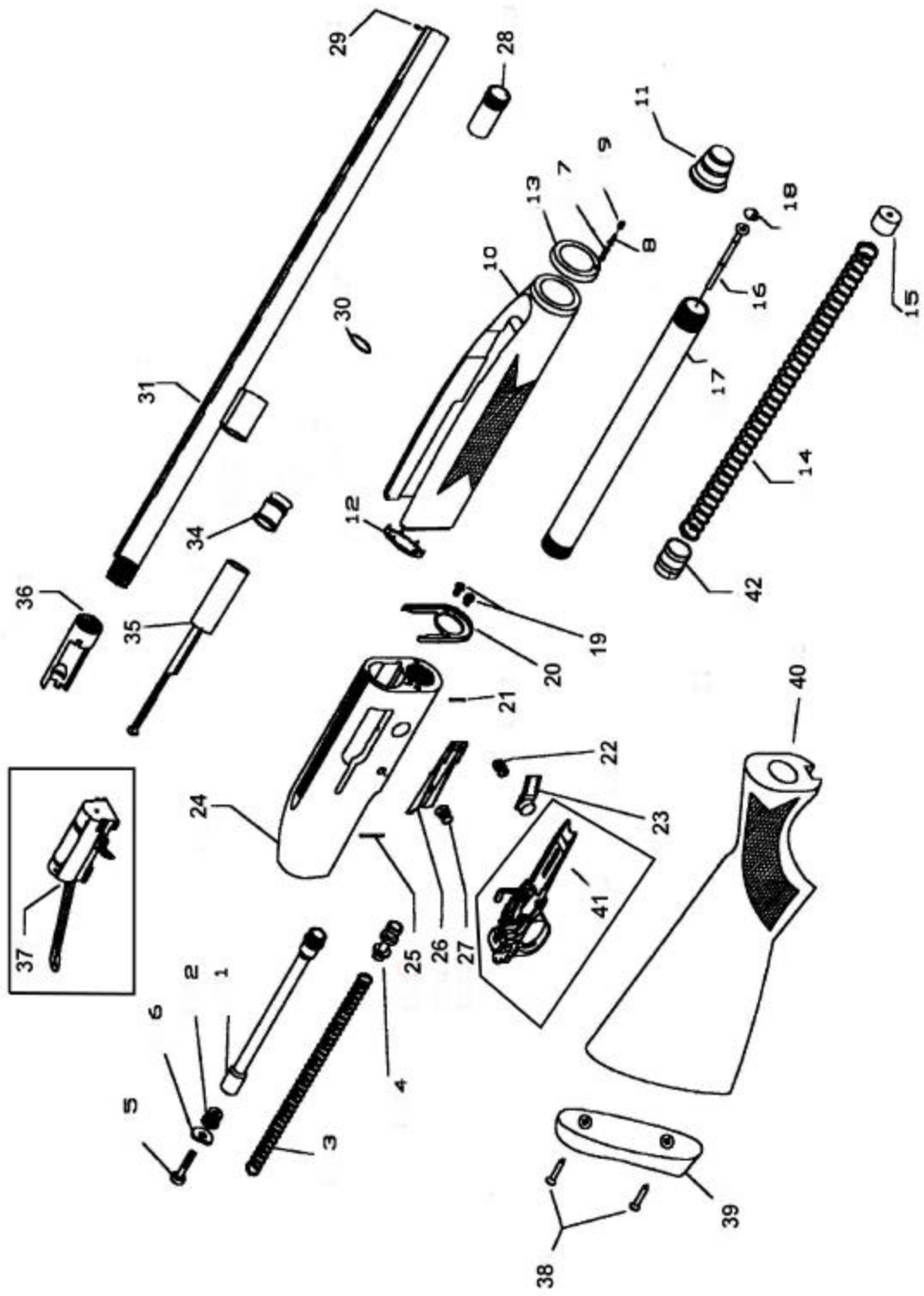

EXPLODED VIEW DIAGRAM

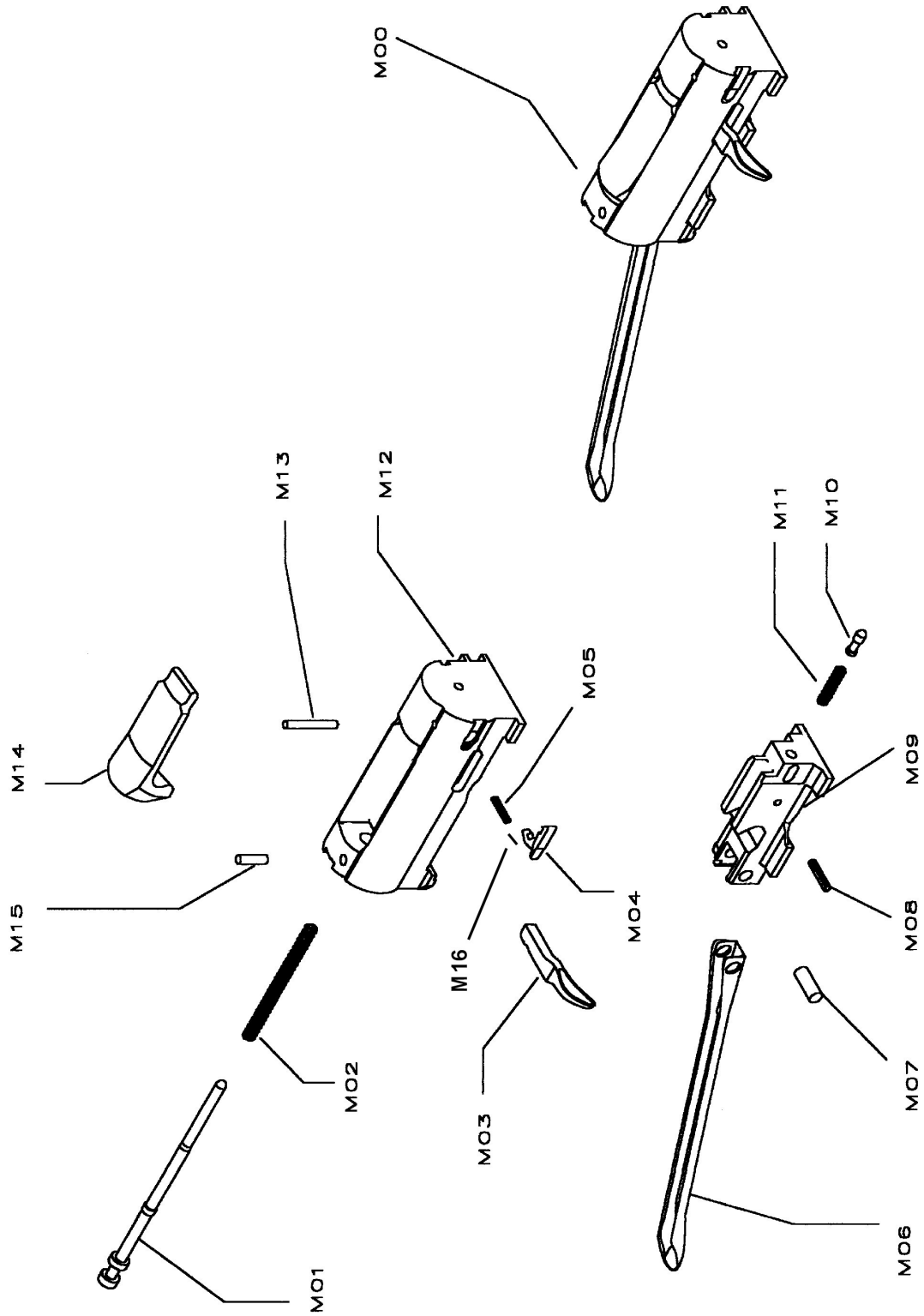

EXPLODED VIEW DIAGRAM

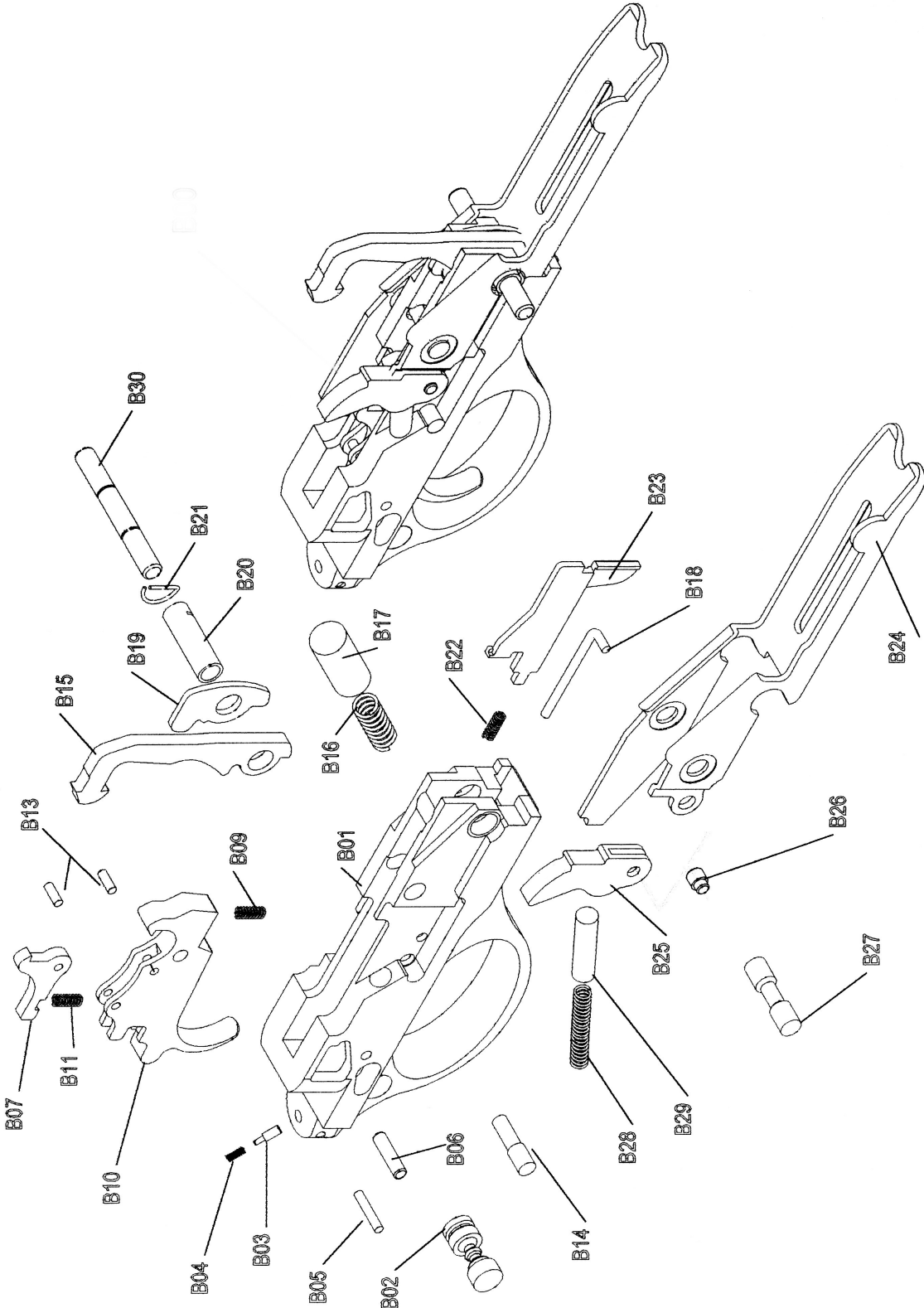

PARTS LIST

General Gun Assembly

- 1) Recoil spring tube
- 2) Nut, stock retaining
- 3) Spring, recoil
- 4) Cap, recoil spring
- 5) Screw, stock retaining
- 6) Washer, stock retaining
- 7) Spring, cap stop
- 8) Screw, cap stop
- 9) Plunger, cap stop
- 10) Forend
- 11) Magazine cap
- 12) Forend pinned plate
- 13) Forend plate
- 14) Spring, magazine
- 15) Retainer, magazine spring
- 16) Magazine plug
- 17) Magazine tube
- 18) Magazine plug blocker
- 19) Screw, forend latch
- 20) Forend latch
- 21) Pin, cartridge latch button
- 22) Spring, cartridge latch button
- 23) Bolt release button
- 24) Receiver
- 25) Pin, cartridge latch
- 26) Cartridge latch
- 27) Spring, cartridge latch
- 28) Choke tube
- 29) Front sight
- 30) "O" ring, gas cylinder
- 31) Barrel
- 34) Piston
- 35) Slide arm assembly
- 36) Barrel extension
- 37) Bolt assembly
- 38) Screw, recoil pad
- 39) Recoil pad
- 40) Stock
- 41) Trigger assembly
- 42) Magazine follower

Bolt Assembly

- M01) Firing pin
- M02) Firing pin spring

- M03) Bolt handle
- M04) Extractor
- M05) Spring, extractor
- M06) Link
- M07) Pin, link
- M08) Pin, bolt handle spring retaining
- M09) Sliding bar block
- M10) Pin, bolt handle
- M11) Spring, bolt handle pin
- M12) Bolt
- M13) Pin, extractor
- M14) Locking block
- M15) Pin, firing retaining
- M16) Plunger, extractor spring

Trigger assembly

- B01) Trigger guard
- B02) Safety
- B03) Pin, safety plunger spring
- B04) Spring, safety plunger
- B05) Pin, safety spring retaining
- B06) Pin, trigger stop
- B07) Disconnecter
- B09) Spring, trigger
- B10) Trigger
- B11) Spring, disconnecter
- B13) Pin, disconnecter
- B14) Pin, trigger pivot
- B15) Hammer
- B16) Spring, hammer
- B17) Cap, hammer spring
- B18) Carrier latch connector
- B19) Carrier latch
- B20) Hammer tube
- B21) Hammer tube "D" ring
- B22) Spring, carrier lock button
- B23) Carrier lock button
- B24) Carrier
- B25) Breech bolt latch
- B26) Pin, breech bolt latch
- B27) Pin, carrier
- B28) Spring, breech bolt latch
- B29) Breech bolt latch spring cap
- B30) Pin, receiver

INTRODUCTION

Thank you for buying a Weatherby® firearm, and welcome to the family. We realize that you had many products to choose from and hope you feel as we do, that you purchased the finest quality production firearm on the market today.

When my late father started this company in 1945, it was as a means to turn his revolutionary vision of rifle design and cartridge performance into practical realities.

At the time, I'm sure he had little idea that the Weatherby® name would come to be one of the most respected and revered in the firearms industry. That is a level of respect we appreciate and you have our assurance that it will not be taken for granted.

This Owner's Manual is designed to assist you in learning how to use and care for your Weatherby® semi-auto shotgun. Please read it very carefully and follow all instructions and safety warnings.

In closing, let me assure you that we are committed to the hunter, shooter and sportsman; and delivering the uncompromising craftsmanship, performance and value that you require in all that we do.

Good Shooting!

WEATHERBY SERVICE POLICY

Weatherby is a name that has been synonymous with quality firearms for over 50 years. All Weatherby® firearms are manufactured of the finest materials and have been thoroughly inspected and tested in every phase of production. Because of the confidence we have in our products, Weatherby does not provide a written warranty, but rather stands behind its reputation for customer service and satisfaction.

Simply stated, we will consider requests for service or repair of Weatherby® firearms without charge on a case by case basis. A determination will be made taking into consideration such things as the age and condition of the firearm, and the circumstances surrounding its malfunction or other problem.

Weatherby, Inc. will not be responsible for defects resulting from ordinary wear and tear, alterations by unauthorized persons, accidents, misuse, use of incorrect or other than factory loaded ammunition, or failure to provide reasonable and normal maintenance.

Should any Weatherby® firearm require service or repair under this service policy, it must be delivered transportation prepaid to a Weatherby Authorized Service Center (names and addresses of which can be supplied by Weatherby upon request). The product must be accompanied by a proof of purchase and a letter explaining the problem. It should also be insured by the owner at the time of shipment, as Weatherby, Inc. can accept no responsibility for damage or loss in transit. Weatherby will pay all charges to return the product to the owner if it is accepted for service or repair without charge under the provisions of this service policy. Weatherby, Inc. also reserves the right to repair or replace any product at our sole discretion.

WEATHERBY, INC. SHALL NOT BE LIABLE FOR ANY CONSEQUENTIAL, INCIDENTAL OR CONTINGENT DAMAGES.

TEN COMMANDMENTS OF FIREARMS SAFETY

Prevention is the solution to hunting and shooting casualties. Every hunting and shooting accident that has occurred could have been prevented. Most such accidents happen as a result of people ignoring basic firearms safety rules. Prevention involves knowing and obeying those basic safety rules. Responsible, knowledgeable, and safe hunters and shooters will learn, remember and follow these simple rules:

1. Control the direction of your firearm's muzzle. Carry your firearm safely, keeping the safety on until ready to shoot. Keep your finger off the trigger until ready to shoot.
2. Identify your target and what is beyond it. Know the identifying features of the game you hunt or the targets you intend to shoot.
3. Treat every firearm with the same respect due a loaded firearm.
4. Be sure the barrel and action are clear of obstructions and that you have only ammunition of proper size for the firearm you are carrying.
5. Whenever not in use, keep your firearm unloaded and store all ammunition in a separate location.
6. Never point a firearm at anything you do not want to shoot. Avoid all horseplay with a firearm.
7. Never climb a fence or tree, or jump a ditch or log, with a loaded firearm. Never pull a firearm toward you by the muzzle.
8. Never shoot at a flat hard surface or water. During target practice, be sure your backstop or shot-fall area is adequate.
9. Store firearms and ammunition separately beyond the reach of children and careless adults.
10. Avoid alcoholic beverages or other mood-altering drugs before or while shooting.

EXERCISE EXTREME CAUTION

Heed and follow these additional gun handling warnings whenever using any firearm

- Be sure the barrel is clear of any obstruction before loading. Make it a habit to check the barrel every time before reloading.
- Never place a loaded gun into a vehicle or lean the gun against any object. The gun should be emptied and placed into a case when not in use.
- Keep the safety on at all times. Move the safety to the "FIRE" position only when you are sure that a shot is imminent.
- While loading or unloading, make sure the gun is pointed in a safe direction. Keep your finger off the trigger while operating the action.
- Treat every gun as if it is loaded - it may be!
- If you do not thoroughly understand the proper use and care of your gun, seek the advice of someone you know is competent.
- Do not abuse your hunting privileges. Both can be taken away from you due to public pressure against "slob" hunters.

Weatherby®

SEMI-AUTOMATIC SHOTGUN
OWNER'S MANUAL

WEATHERBY® is a registered trademark of Weatherby, Inc.

