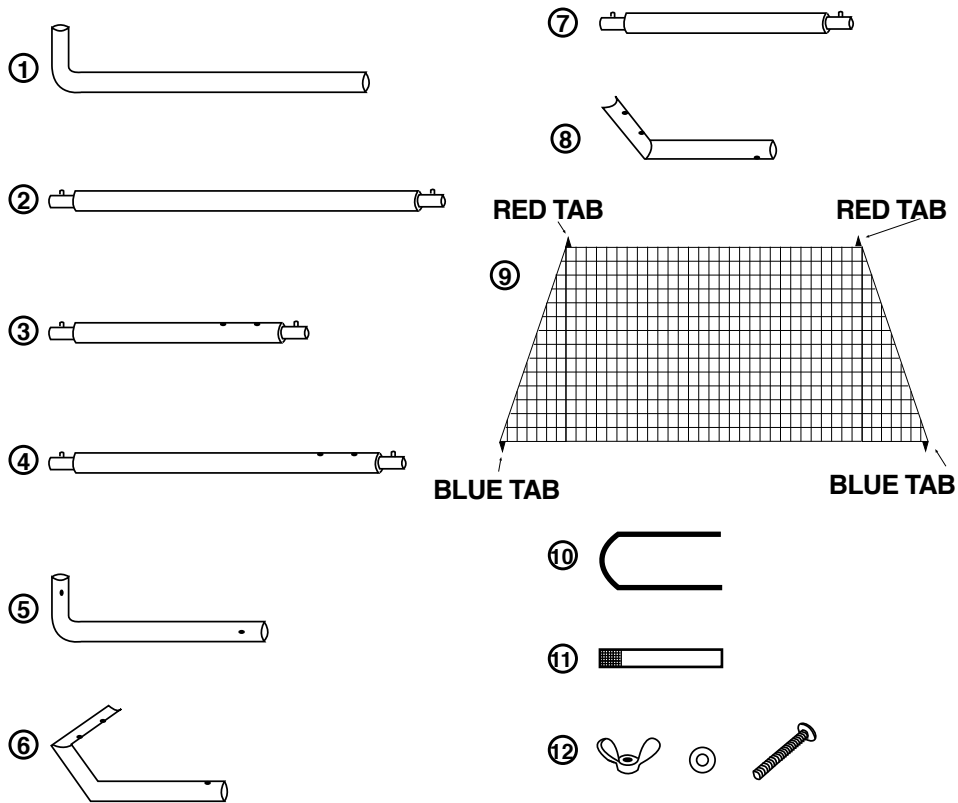

Figure #1 FRAME COMPONENTS



PART	QTY	DESCRIPTION	
①	4	L Shaped Tube	8 1/4in x 47 1/4in (21cm x 120cm) (one end perforated)
②	2	Straight Tube	53in (134.6cm) (metal snaps on both tapered ends)
③	2	Straight Tube	36 7/8in (93.7cm) (metal snaps on both tapered ends)
④	2	Straight Tube	48in (1.22m) (metal snaps on both tapered ends)
⑤	2	L Shaped Tube	8 1/4in x 31 1/2in (21cm x 80cm) (both ends perforated)
⑥	2	J Shaped Tube	12 1/2in x 22 5/8in (30.5cm x 57.5cm)
⑦	2	Straight Tube	35 1/2in (90.2cm) (metal snaps on both tapered ends)
⑧	2	Bent Tube	22 7/8in (58.1cm)
⑨	1	Mesh Net	24ft x 8ft x 4in (7.31m x 2.44m x 10.2cm)
⑩	6	U Shape Ground Stake	8in (20.3cm)
⑪	40	Self-Stick Closure Strips	8in x 3/4in (20.3cm x 1.91cm)
⑫	8	Hardware Set	metal: screw/washer/wing nut

Figure #2 FRAME ASSEMBLY

Assemble all lengths of tubing shown in Figure 1. Be sure that each piece is inserted completely. The ends of each tube insert tightly and is secured when the press button of the tapered end pops through the adjoining perforated tube.(Figure 2A)

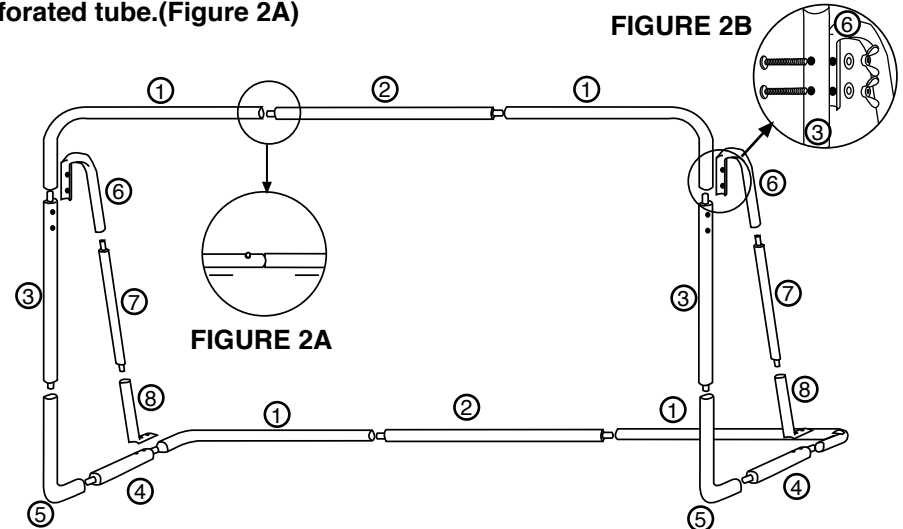

Step Assembly Instructions

- Assemble the first set of tubes, parts ① & ②. This will create the back base.
- Insert tapered tubes, part ④, to the back base. The end with the two holes needs to be attached closest to the back.
- Insert L shaped tubes, part ⑤, as shown into the side base section of tubes part(s).
- Insert tapered tubes, part ③, into the upward reaching base. The end with the two holes needs to be at the top.
- After assembling the second set of tubes, parts ① & ②, place these on the two tapered sections, part ③, to complete the frame.
- Assemble the two reinforcement sections by connecting parts ⑥, ⑦, & ⑧. The J shaped section, part ⑥, is the upper section while the bent tube numbered ⑧ attaches to the base.
- Align the ② holes from J tube with the two holes in tube ③. Using one set of hardware, insert the screws through the two sets of tubes from the front. When the screw passes through the two tubes place the washer on the screw then add the butterfly. Turn the butterfly clockwise to tighten. Repeat with the 2nd set of hardware. (Figure 2B)
- Align the two holes from the bent tube with the two holes in tube ④. Using one set of hardware, insert the screws through the two sets of tubes from the base. When the screw passes through the two tubes place the washer on the screw then add the butterfly. Turn the butterfly clockwise to tighten and secure the tubes together. Repeat with 2nd set of hardware.

Job Number: 102332-1 File Name: 5680-IS2.ai Product Division: Inflated Product Line: Core Original Artist: Last Modified By: Mary Ellen Mazzoli Date Created: 7.11.12 Date Approved On:

Primary Pantone Color Palette
4 color process



Black

Secondary Pantone Color Palette
4 color process

Logo Color Pantone Palette
4 color process

Creative Manager Approval: _____

Product Manager Approval: _____

Traffic Manager Approval: _____

Legal Approval: _____

Franklin