

Infrared Digital Scouting Camera



User's Manual

Model # r12i20

Includes



T-Post Support

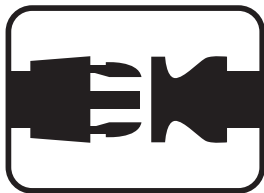

Adjustable Strap

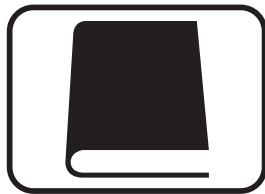

User Manual

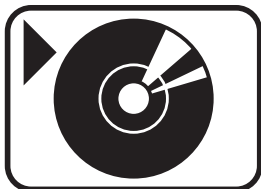

**Flextime Player
Software**

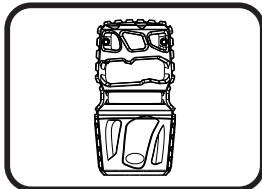

Camera Unit

NOTE: Flextime Player Software is optional. Flextime files can be played by using most media players

Features

RESOLUTION	MAX: 12 MP Still
FLASH	36 High Intensity Infrared LED's
FLASH RANGE	up to 70 feet
SENSOR	Passive Infrared Sensor (PIR) Motion and Heat
SENSOR RANGE	up to 60 feet
IMAGE FORMAT	JPEG - Digital Stills/ AVI-Digital Video
MEMORY	up to 32GB SD Card (not included and required) Class 4 and above recommended
IMAGE RESOLUTION	High (12 MP) Medium (8 MP) Low (5 MP)
POWER SUPPLY	8 AA batteries (not included and required) Alkaline recommended
AUXILIARY POWER	External power port
ONBOARD POWER	Built in capacitor to retain Date and Time
HOUSING	Weather resistant with rubber gaskets
MOUNTING	Adjustable Strap and custom T-Post mounting bracket system - included

Note: Battery life will vary depending on camera settings as well as environmental conditions. Camera settings such as shorter delay periods or even using Flextime mode are examples of settings that can reduce overall battery life. Environmental conditions such as extreme cold can also influence battery life.

Installing Batteries

1. Open the door on the right of the camera and PULL the tab towards you.

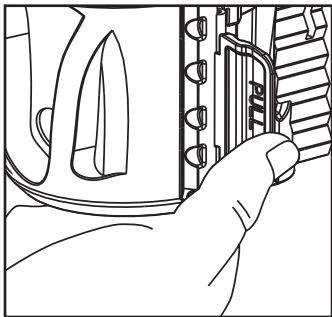

2. With the camera facing up, open the compartment door.

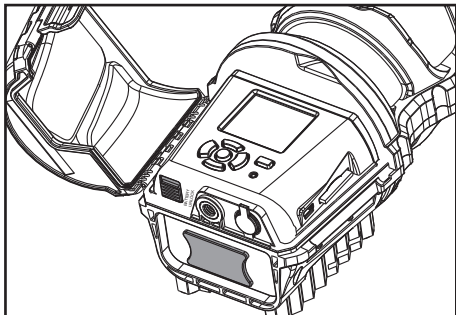

Push the battery latch up to unlock. At the same time grab the battery compartment out.

- 3.** Make sure to insert the AA-cell batteries based on the direction labeled on the inside of each compartment. Match minus “-” sign with the marked negative on the battery and the plus “+” sign with the marked plus sign on the battery.

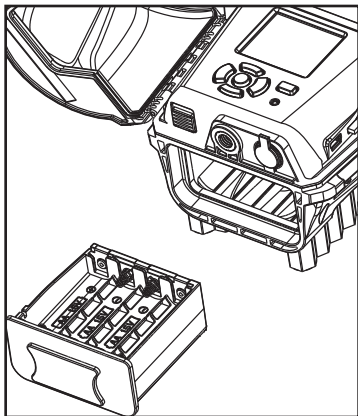

Once the batteries are in the appropriate spot, return battery compartment.

- 4.** Load SD memory card (up to 32GB not included) into the SD CARD slot with the connectors facing down.

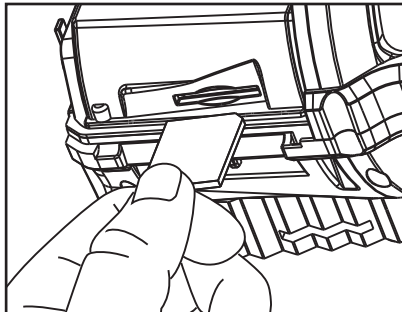

IMPORTANT:

Make sure the camera is powered off before removing or installing an SD card.

If you are using an SD card from other cameras, please make sure to format the SD card in your computer prior to use in your camera. New cards are ok to use straight from the package.

Power On

1. To turn the unit ON press and release the power button.

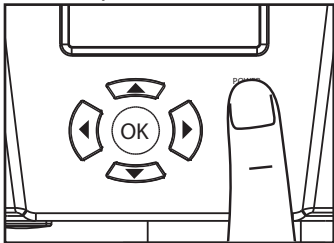

2. Check the battery level icon to ensure the batteries just installed contain the proper charge level. If so, you are ok to proceed with camera use.

TIME/DATE ▶	PM 04:32	
LOCATION		
TRIGGER	PIR MODE	FLEXTIME BOTH
FLEXTIME	P1	P2 INTERVAL
PIR MODE	STILL	VIDEO
PIR ACTIVE	24 HR	DAY NIGHT
PIR SENSE	HI	MED LO
EXPOSURE	HI	MED LO
STILL RES	HI	MED LO
PIC/VIDEO	REGULAR	WIDE
DELAY	15s	30s 1m 5m 10m



NOTE: LCD cycle through camera information. Time → PIR picture number → Flextime number → Remaining pictures → Temperature

Test Mode

1. LCD Ready Mode: The camera will automatically enter Ready Mode if a button is not pressed for greater than 30 seconds. The status lights will illuminate for a total of 2 minutes.
2. PIR LED Status Light: During the first 2 minutes of Ready Mode, the red light will illuminate when a PIR event is triggered. The red light will blink for 2-3 seconds when photo is taken during this first 2 minutes. After 2 minutes all indicator lights will turn off until a button is pressed.

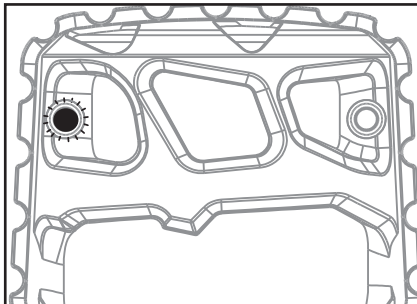

Power Save

1. After 30 seconds without any buttons being pushed, the LCD will turn off and camera enters into Power Save or Ready Mode.
2. The LCD screen can be awakened by pressing the Power button briefly.

Note: The LCD will not “wake up” when camera is writing to memory.

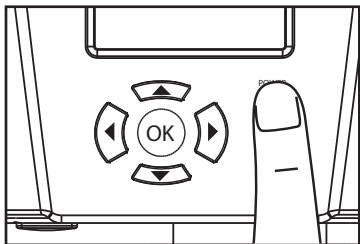

Setting Time

1. To change date and time, start by pressing and release the OK button to set the hour.

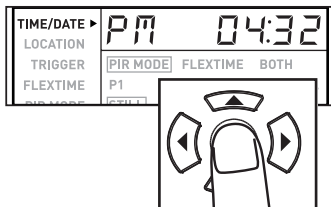

2. Press the up or down navigation button to go up or down in sequence.

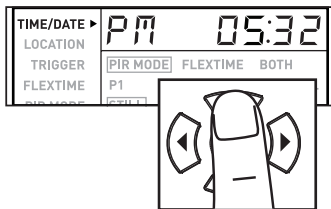

3. When the hour is set, repeat steps 1 and 2 to set the minutes.

Setting Date

1. Press the OK button after setting the minute to change the Day.

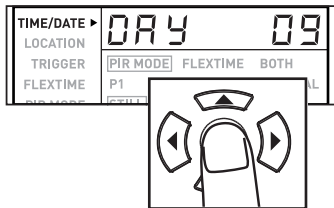

2. Press the up or down navigation button to go up or down in sequence.

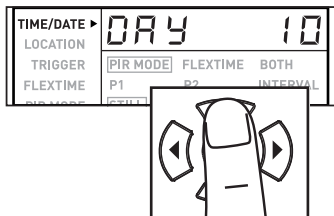

3. When the DAY is set, repeat steps 1 and 2 to set the Month and Year.

Location

Save the location of the area the camera was installed. This is for your reference and is optional. If you do not wish to name your location skip to the next step.

1. Press the OK button while LOCATION is selected. The first character will be blinking.

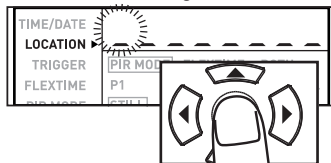

2. Press the UP or DOWN navigation button to go up or down in sequence. Press the OK button or the Left and Right navigation button when the character shown is what you want and move to the next character.

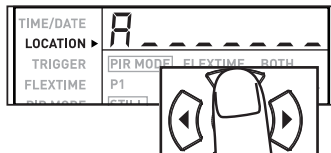

3. Repeat steps 1 and 2 to set the rest of the characters. Press the right navigation button to skip spaces and save the location name.

Trigger

This setting allows you to choose the mode in which the camera will be capturing images.

1. Press the OK button while Trigger is selected. The highlighted option will be blinking.

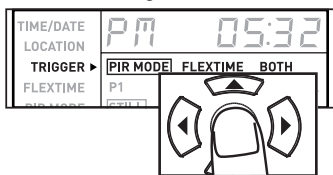

2. Press the left or right navigation button to move to different options. Press the OK button to save the setting.

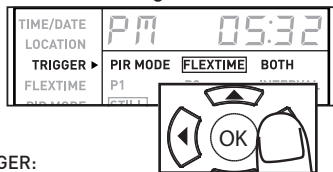

TRIGGER:

PIR MODE: Takes a photo only when the PIR sensor is triggered.

FLEXTIME (Time Lapse): Takes time lapse images at set intervals during the key movement periods of the day, depending on your Flextime settings.

BOTH: Both PIR and Flextime are active.

Flextime

1. Press the OK button while Flex-time is selected. The highlighted option will be blinking.

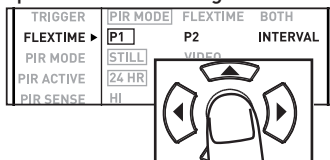

2. Press the left or right navigation button to move to different options. Press the OK button to save the setting.

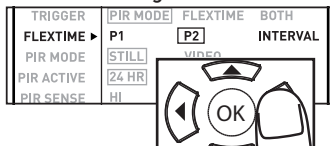

The Interval setting is set by the Delay Setting on the camera with a 1 minute minimum Flextime delay. See chart on the next page for Flextime options.

NOTE: Camera needs at least 48 hours in the field to acclimate to the environment for Flex-time to function properly.

Reminder: Only use “Flextime” and “Both” modes if you are wanting to use time lapse technology. These modes can reduce battery life versus the standard “PIR” mode.

FLEXTIME selected

Flextime period:

- 15 min before Sunrise to 1 hour after Sunrise.
- 1 hour before Sunset to 15 min after Sunset

P1

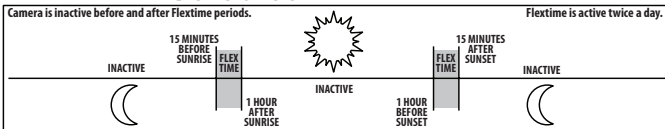

Flextime period:

- 15 min before Sunrise to 1 hour after Sunrise.
- 1 hour before Sunset to 15 min after Sunset

P2

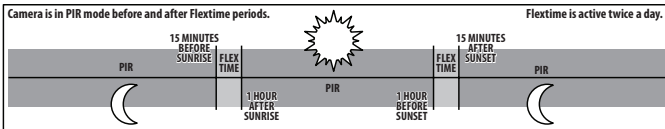

Flextime period:

- 15 min before Sunrise to 15 min after Sunset

INTERVAL

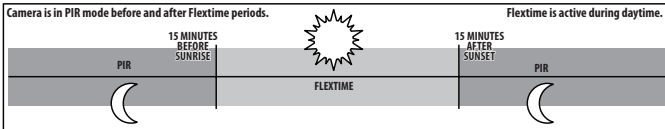

BOTH selected

Flextime + PIR period:

- 15 min before Sunrise to 1 hour after Sunrise.
- 1 hour before Sunset to 15 min after Sunset

P1

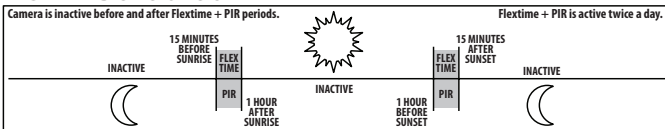

Flextime + PIR period:

- 15 min before Sunrise to 1 hour after Sunrise.
- 1 hour before Sunset to 15 min after Sunset

P2

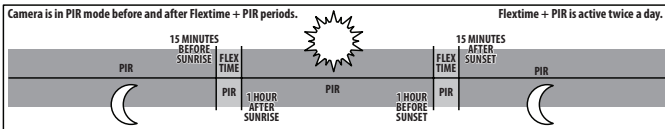

Flextime + PIR period:

- 15 min before Sunrise to 15 min after Sunset

INTERVAL

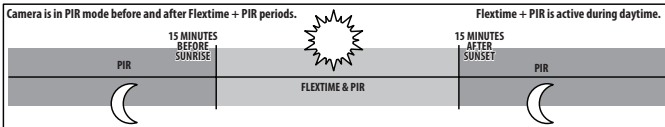

PIR Mode

1. Press the OK button while PIR Mode is selected. The highlighted option will be blinking.

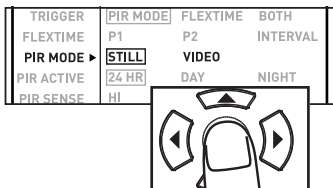

2. Press the left or right navigation button to move to different options. Press the OK button to save the setting.

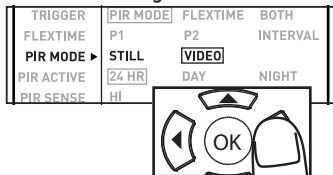

PIR MODE:

STILL: The camera takes still photographs.

VIDEO: The camera takes 30 second videos.

PIR Active

1. Press the OK button while PIR Active is selected. The highlighted option will be blinking.

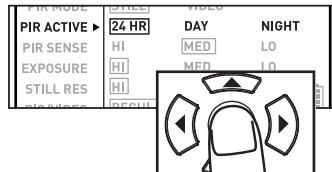

2. Press the left or right navigation button to move to different options. Press the OK button to save the setting.

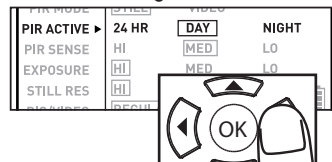

PIR ACTIVE:

24 HR: The PIR can be active at all times.

DAY: The PIR can be active in daylight hours only.

NIGHT: The PIR can be active in nighttime hours only.

PIR Sensitivity

1. Press the OK button while PIR Sense is selected. The highlighted option will be blinking.

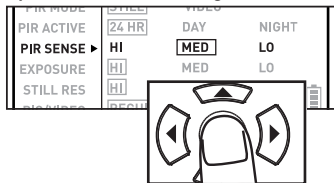

2. Press the left or right navigation button to move to different options. Press the OK button to save the setting.

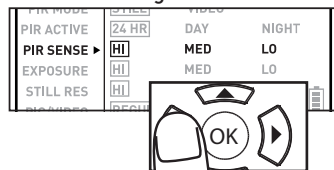

PIR SENSE:

HI: The PIR detects the smallest movement.

MED: (Default) The PIR detects most common size movements.

LO: The PIR detects only larger movements.

Exposure

1. Press the OK button while Exposure is selected. The highlighted option will be blinking.

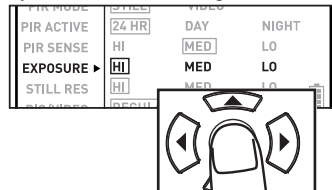

2. Press the left or right navigation button to move to different options. Press the OK button to save the setting.

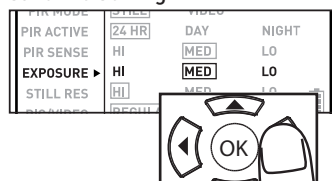

EXPOSURE:

HI: Greatest distance with some motion blur.

MED: (Default) Long distance with little motion blur.

LO: Average distance with very little motion blur.

Resolution

1. Press the OK button while Resolution is selected. The highlighted option will be blinking.

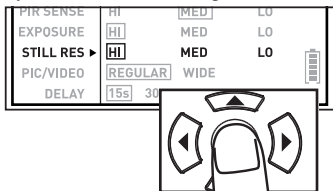

2. Press the left or right navigation button to move to different options. Press the OK button to save the setting.

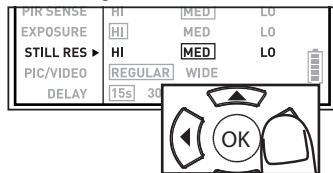

RESOLUTION:

HI: Images will be at the highest resolution but take up the most space.

MED: Images will be at medium resolution and take up average space.

LO: Images will be at the lowest resolution and take up the least space.

Picture/Video

1. Press the OK button while Picture is selected. The highlighted option will be blinking.

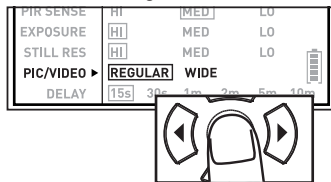

2. Press the left or right navigation button to move to different options. Press the OK button to save the setting.

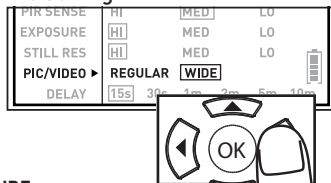

PICTURE:

REGULAR: Images taken will be in regular angle or 4:3 aspect ratio.

WIDE: Images taken will be in wide angle or 16:9 aspect ratio.

VIDEO:

REGULAR: Videos taken will be in 480p resolution.

HD: Videos taken will be in 720p resolution.

Delay

1. Press the OK button while Delay is selected. The highlighted option will be blinking.

PIR SENSE	HI	MED	LO		
EXPOSURE	HI	MED	LO		
STILL RES	HI	MED	LO		
PIC/VIDEO	REGULAR	WIDE			
DELAY ▶	15s	30s	1m		5m



2. Press the left or right navigation button to move to different options. Press the OK button to save the setting.

PIR SENSE	HI	MED	LO		
EXPOSURE	HI	MED	LO		
STILL RES	HI	MED	LO		
PIC/VIDEO	REGULAR	WIDE			
DELAY ▶	15s	30s	1m		5m



DELAY: The time before the camera is able to take another picture.

PIR Mode: minimum 15s

FLEXTIME Mode: minimum 1 minute

Power Off

1. To turn the unit off, first wake up the LCD screen and then depress and hold the power button until the LCD turns off.

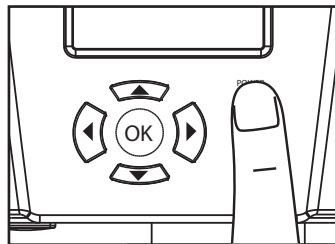

Reset

Reset button located next to the battery compartment. Push button to reset settings back to factory settings.

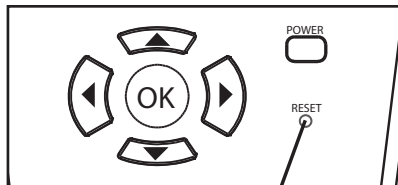

Power Port

1. WGI Cameras come standard with an external power port. You must open the weather resistant cover and use a Wildgame Innovations 6 Volt camera battery accessory.

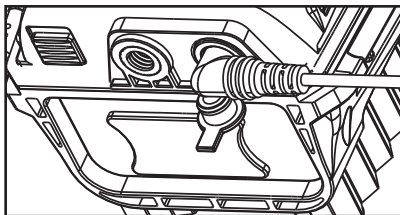

NOTE:

The  icon will appear when the 6 volt battery accessory is connected to the unit properly.

Image Stamp

Pictures Display:



- A- Temperature
- B- Time
- C- Date
- D- Moon Phase
- E- Location
- F- Photo Count

Mounting

1. When mounting to a tree, first remove the clip from one end of the strap so you can slide the strap through the slots located on the back of the camera. Once the camera is attached place the clip back on to the strap. Then, wrap the strap around the tree and clip the two ends together. Pull the excess material so that the camera is strapped tightly to the tree.

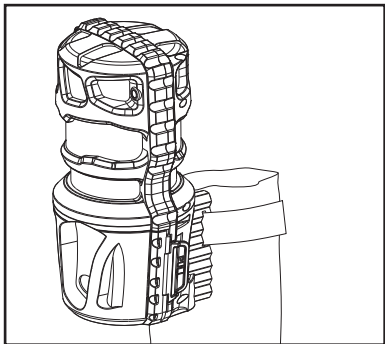

1. When mounting to a T-Post, first attach the T-Post bracket to the camera.

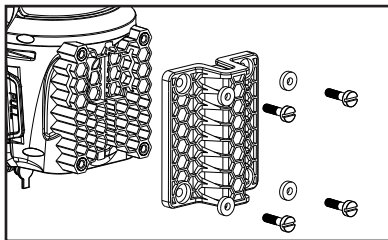

2. Once the camera is attached connect the T-Post bracket to your T-Post.

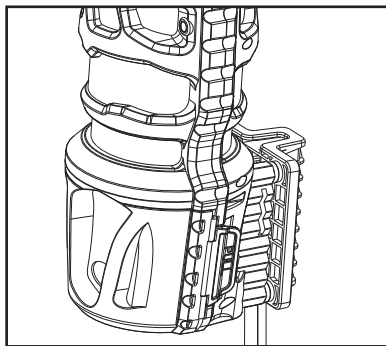

Important

There is also a standard 1/4"-20 tripod connector.

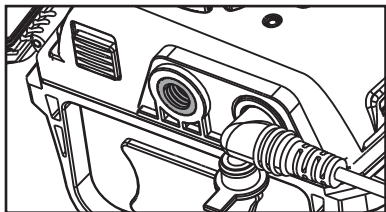

The directions as contained herein assume that you are using a Microsoft operating system and not Linux or a Mac-based operating system. Even said, there may be slight variations in your process based on the specific version of the operation system that you are using as well as the predefined user preference for each computer. The below listed steps are to serve as a guideline and may have to be slightly modified based on the specific operating system and preference as on your personal computer.

TIPS:

Recommended distance from target area is 25-30 feet for optimal imaging quality.

To improve the quality of your images, try not to mount the unit facing the rising or the setting sun in order to avoid direct sunlight into the camera lens.

If mounting to a feeder unit or dusty environment, be sure to clean the camera lens cover, incandescent flash cover, and the PIR sensor cover on a regular basis.

Periodically check the mounting of the camera to insure it is not loose.

Make sure that you securely latch the door closed each and every time you use the unit, as the moisture seal will not be activated unless closed properly.

Check batteries frequently to insure no corrosive build-up, as this may cause harm to the camera.

Retrieving Images (SD Card Reader)

Method 2: Remove SD card and use card reader

A. First, remove the SD Card from the camera unit itself by pressing on it to where it automatically ejects.

B. Next, insert the SD card into your SD card reader.

C. Once inserted into your computer it may automatically launch "AutoPlay", a window recognizing a new Secure Digital Storage Device (the SD Card).

D. If so, it should list several options for the next steps (not limited to the following):

1. Picture Options
 - a. Import pictures
 - b. View pictures
 - c. Copy Disc
 - d. Transfer pictures

2. General Options
 - a. Open folder to view files

E. Select the method from the list provided that best suits your requirements. If the selection is made to "View pictures", you can then view the images located on the SD Card and manipulate them as needed.

F. If your computer does not automatically launch the AutoPlay window recognizing the Removable Disk (the SD Card), then you will need to go to the "Start Menu" at the bottom

left of your screen and select "Computer". The summary view will then be illustrated on the right hand side of the window where by the "Devices with Removable Storage" will be listed. The computer will recognize the reader as "Secure Digital Storage Device". Please select "Secure Digital Storage Device" from this menu (or double click on the graphical icon).

G. This will then direct you into the SD Card file folder. Images are in the MEDIA folder while Flextime files are in the FLEX folder.

H. Once open, you will then see all of the photo files that are located on the SD Card. Select each image individually to view. The default viewing browser for your computer will then automatically launch.

I. Repeat for viewing all or other photos.

J. If you determine that you want to delete the image, select the image by placing your cursor on it and clicking your mouse only once. Right click on your mouse and select delete. This will delete the image permanently, so be absolutely sure you want to do this before selecting delete.

Warranty

DISCLAIMERS

WGI Innovations, LTD. is not responsible for damage, expense or injury caused by the unauthorized use of, alterations to, improper connection of and abuse or neglect of the WGI Innovations™ products.

WARRANTY

For the warranty to be in effect, you MUST completely fill out and mail the warranty card along with your proof of purchase to WGI Innovations within (14) days after the date of purchase. As an alternative to mail, you may also visit our website and register your product at www.wildgameinnovations.com (you are still required to mail WGI Innovations your proof of purchase before the warranty is placed in effect.) Follow the onscreen directions to complete the process.

WGI Innovations, LTD will replace all workmanship defects free of charge for ONE (1) YEAR after the date of purchase as long as your warranty is in effect.

This warranty DOES NOT COVER damage, expense or injury caused by unauthorized repairs, alterations, improper connection, shipping, abuse, theft, accident, animal damage, neglect or collateral loss.

When returning product(s) for service you MUST obtain a Return Merchandise Authorization (RMA) number from WGI Innovations, LTD. Please include name, UPS address (No P.O. Box), telephone number, RMA number and a complete description of the problem on all enclosed correspondence. When possible, pack product carefully in original carton. Customers are responsible for any shipping cost to WGI Innovations. WGI Innovations will pay the shipping cost of replacement product to the customer. We are not responsible for damage incurred in returning items for repair.

For product service send to:

WGI Innovations
602 Fountain Parkway
Grand Prairie, TX 75050
(800) 847-8269

Thank you for your purchase!

CUSTOMER SERVICE

WGI Innovations, LTD. stands behind every product we manufacture for a one year product workmanship warranty and a strong commitment to customer service. If you are in need of customer service for missing parts or need assistance with the operation or assembly of your product, we encourage you to call one of our customer service representatives and let us assist you with your WGI Innovations product.

DISCLAIMER

WGI Innovations, LTD. reserves the right to make changes to product features, functionality and physical design at its sole discretion. As a result, such changes may not be reflected in this version of the manual.

FCC STATEMENT

Product Name: Game Trail Camera

Trade Name: Wildgame Innovations

Model# r12i20

This device complies with Part 15 of the FCC Rules. Operation is subject to the following two criteria: (1) This device may not cause harmful interference, and (2) This device must accept any interference received, including interference that may cause undesired operation.

Warning: Changes or modifications to this unit not expressly approved by the party responsible for compliance could void the user's authority to operate the equipment.

NOTE: This equipment has been tested and found to comply with the limits for a Class B digital device, pursuant to Part 15 of the FCC Rules. These limits are designed to provide reasonable protection against harmful interference in a residential installation. This equipment generates, uses and can radiate radio frequency energy and, if not installed and used in accordance with the instructions, may cause harmful interference to radio communications.

However, there is no guarantee that interference will not occur in a particular installation. If this equipment does cause harmful interference to radio or television reception, which can be determined by turning the equipment off and on, the user is encouraged to try to correct the interference by one or more of the following measures:

- Reorient or relocate the receiving antenna.
- Increase the separation between the equipment and receiver.
- Connect the equipment into an outlet on a circuit different from that to which the receiver is connected.
- Consult the dealer or an experienced radio/TV technician for help.

This device complies with Industry Canada licence-exempt RSS standard(s). Operation is subject to the following two conditions: (1) this device may not cause interference, and (2) this device must accept any interference, including interference that may cause undesired operation of the device.

WGI INNOVATIONS, LTD

602 Fountain Parkway
Grand Prairie, TX 75050
800.847.8269



"Wildgame Innovations" and the "Button Logo" are TM trademarks of Wildgame Innovations, LLC.
"Sport Responsible" and "Flexitime" are TM trademarks of WGI Innovations, LTD.

