

User's Manual

Models OWTC12, STEC12B,
STEC12R, STEC12G

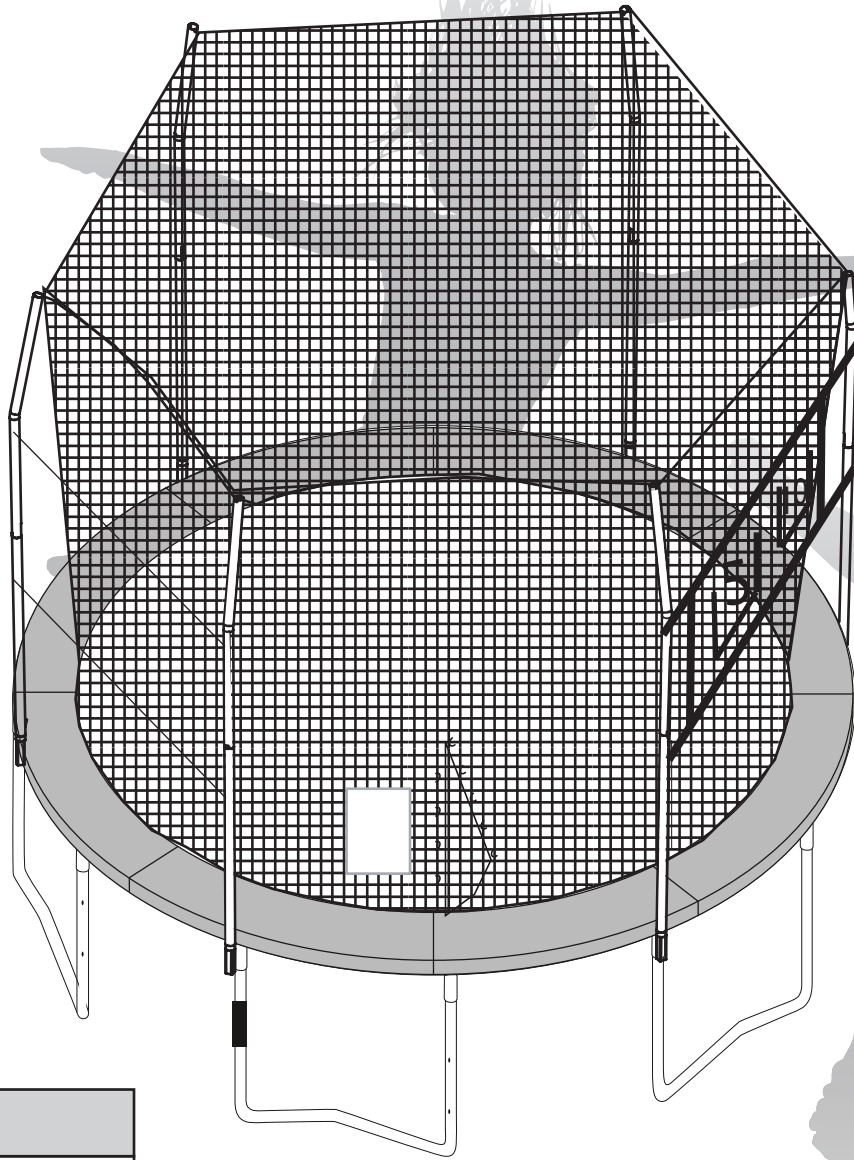

WARNING

Read all precautions and instructions in this manual before using this equipment. Save this manual for future reference.
Maximum user weight 200 lbs



CAUTION: Adult Assembly Required



IMPORTANT

Trampoline and Enclosures are susceptible to winds. Be sure to secure your trampoline and enclosure.
Wind Damage is not covered in the warranty of your trampoline

SKYWALKER

TRAMPOLINES™

Models OWTC12, STEC12B, STEC12R, STEC12G

A serial decal is found on one of the trampoline legs. Model number decal tag is located on the jumping mat.

CONTENTS

Important Precautions.....	3
Warning Label Placement.....	4
Before You Begin.....	4
Trampoline Safety Information.....	5
Enclosure Safety Information.....	6
Methods of Accident Prevention.....	7
Important Warnings	8
Use and Instructional Material.....	9
Instructional Program and Model Lessons	10-11
Part Identification Chart	12
Exploded Drawing and Parts List.....	13-14
Ordering Replacement Parts.....	14
Assembly.....	15-23
Care and Maintenance.....	24
Throw Back Game	25
Limited Warranty.....	26

QUESTIONS?

If you have questions after reading this manual, please call our toll-free Customer Care Hot Line. The trained technicians on our Customer Care Hot Line will provide immediate assistance.

Customer Care Hot Line: 1-866-603-Jump(5867) Monday—Friday, 8a.m.—5p.m. MountainTime

REPLACEMENT PARTS

www.skywalkertrampolines.com

WARNING

Read the assembly, installation, care, maintenance, and use instructions in this manual prior to assembling and using this trampoline. Save this manual for future reference.

WARNING

High Wind: The trampoline can be blown around by high winds. If you expect high winds, the trampoline should be moved to a sheltered location, taken apart, or tied down to the ground with ropes and stakes (NOT INCLUDED). At least four ropes and four stakes should be used. Make sure to attach the ropes to the top of the frame: DO NOT simply secure the legs or the bases to the ground, as they can separate from the frame sockets. The top of the stakes should be at ground level so they will not create a tripping hazard. In addition, the top of the stakes should be covered, if necessary, so that users will not be injured by falling on the stakes. The manufacturer's warranty does not cover any type of wind or weather damage.

USE INSTRUCTIONS



To reduce the risk of serious injury, read and follow all of the warnings, precautions, and instructions in this manual before you use the trampoline enclosure. Warnings and instructions for care, maintenance, and use of this trampoline and enclosure are included to promote safe, enjoyable use of this equipment.

1. It is the responsibility of the owner and supervisors of the trampoline and enclosure to make sure all users obey the safety instructions given in this manual. The trampoline should only be used with mature, knowledgeable supervision.
2. Secure the trampoline and trampoline enclosure against unauthorized and unsupervised use. If you use a ladder to get on and off the trampoline, be sure to remove it when the trampoline and enclosure are not being used.
3. Be sure there is enough clear space above the trampoline and enclosure before use. It is best to have at least 24 feet(7.3 meters) of clear space above the ground. This space must be clear of wires, tree limbs, and any other possible hazards.
4. Lateral (sidewise) clearance is very important. Do not place the trampoline and enclosure near walls, buildings, fences, sidewalks, and other play areas. Always keep a clear space on all sides of the trampoline and enclosure.
5. Remove any objects that could interfere with the performer. Maintain a clear area around and under the trampoline.
6. Be sure the trampoline and enclosure are on a level surface before use.
7. Always inspect the trampoline and enclosure before each use. Make sure that the frame, padding, netting, enclosure tubes, and foam sleeves are correctly and securely positioned. Replace any worn, defective, or missing parts.(Jumpers may be hurt if the trampoline and enclosure are used when they are in poor condition.)
8. Bounce only when the surface of the mat (bed) is dry. There should be very little or no wind or air movement. The trampoline and enclosure must not be used in gusty or severe winds.
9. The trampoline and enclosure frames are made of metal. They are not grounded and will conduct electricity. For this reason, an electrocution hazard exists. No lights, electric heaters, extension cords, or household electrical appliances are to be permitted on the trampoline or in enclosure at any time.
10. Use the trampoline and enclosure in an area with lots of light. If the trampoline and enclosure are indoors or in shady areas you may need to use artificial (electrical) lighting in the area.
11. During the winter months the trampoline soft materials will need to be removed and stored in a dry place. If left up in the winter months it may cause damage to the springs, jump mat, spring pad and enclosure. The warranty will be void.
12. This trampoline and enclosure is made for users who weigh less than 200 pounds.
13. Trampoline over 20in.(51cm) tall are not recommended for use by children under 6 years of age.
14. The trampoline enclosure is to be used only with the size of trampoline for which the enclosure is designed.
15. Misuse and abuse of the trampoline enclosure is dangerous and can cause serious injury.
16. Do not attach anything to the enclosure barrier that is not a manufacturer-approved accessory or part of the enclosure system.
17. Please remove any jewelry before jumping begins. Jewelry may get caught in the enclosure netting.
18. Wear clothing free of drawstrings, hooks, loops, or anything that could be caught in while using the trampoline/enclosure and result in entanglement and strangulation, or both.
19. DO NOT let more than one person inside the trampoline enclosure at the same time. Two or more people jumping at the same time can cause serious injury.
20. DO NOT jump on the trampoline while you have or are holding any objects, especially something sharp or breakable.
21. DO NOT use the trampoline and enclosure if you have been using alcohol or drugs.
22. DO NOT attempt or allow summersaults (flips) on trampoline. Landing on the head or neck can cause serious injury, paralysis, or death, even when landing in the middle of the jumping bed.
23. Always climb on to and off of the trampoline. It is a dangerous practice to jump from the trampoline to the floor or ground when dismounting, or to jump onto the trampoline when mounting. DO NOT use the trampoline as a springboard to other objects.
24. Enter and exit the enclosure only at the enclosure door or barrier made for that purpose.
25. DO NOT attempt to crawl under, jump over, intentionally bounce off of, hang from, climb on, kick, or cut the barrier netting.
26. While keeping head erect, focus eyes on the trampoline toward the perimeter. This will help control bounce.
27. Stop bouncing by flexing knees as feet come in contact with the trampoline bed. Learn this skill before attempting others.
28. Avoid bouncing too high. Stay low until bounce control and repeated landings in the center of the trampoline can be accomplished control in more important than height.
29. Avoid bouncing when tired. Keep turns short.
30. Learn fundamental bounces and body positions thoroughly before trying more advanced skills. A variety of trampoline activities can be carried out performing the basic fundamentals in various series and combinations, performing one fundamental after another, with or feet bounces between them.
31. For additional information concerning the trampoline equipment contact the manufacturer. For information concerning skill training, contact a certified trampoline instructor.



WARNING LABEL PLACEMENT

WARNING

Trampoline Safety Instructions

Do not land on head or neck. Do not attempt or allow somersaults. Landing on your head or neck can cause serious injury, paralysis, or death, even when landing in the middle of the mat. Use trampoline only with mature, knowledgeable supervision.

Only one person at a time on the trampoline. Do not allow more than one person on the trampoline. Use by more than one person at the same time increases the chance of injury. Use trampoline only with mature, knowledgeable supervision. This trampoline is not recommended for children under 6 years of age.

For the Supervisor
Read the instructions before using the trampoline. Follow all of the safety rules and the location with the information in the User's Manual which are shown between pages 14 and 20 to follow trampoline safety.

All trampoline users must have mature, knowledgeable supervision, regardless of the skill or age of the jumper.

This trampoline is not recommended for use by children under 6 years of age.

Inspect the trampoline before using. Keep frame and mat clean. A hole or damaged mat, spring, or frame piece should be replaced immediately.

Keep children away from mat's surface when in use.

Never use trampoline for sport, uncontrolled, or unapproved use.

Do not use when trampoline is wet or in a windy condition.

For the Jumper
Do not use the trampoline when under the influence of drugs or alcohol.

Avoid swinging when used.

Jumping
Land on the mat. Jump and body position vary to help bring down difficult stunts. Study the User's Manual to learn how to land safely.

Use jump height to the ability you have as you do not want to strain the trampoline mat.

Avoid jumping too high for too long. Always control your jump. A controlled jump is one when the take off and land spots are the same.

Always be aware of the trampoline. From your vantage point toward the trampoline mat, it takes a lot of time to see a view of below and around.

Multiple jumpers increase the chance of loss of control, collision and falling off. This can result in broken head, neck, back or legs.

Getting on and off
Climb on or out of the trampoline. Do not jump on or off. Do not use the trampoline as a springboard to other objects.

For further important information contact SEYOUNGER TRAMPOLINES. For all training information, contact a trampoline organization.

ATTACH TO TRAMPOLINE

WARNING

Do not land on head or neck. Do not attempt or allow somersaults. Landing on your head or neck can cause serious injury, paralysis, or death, even when landing in the middle of the mat. Use trampoline only with mature, knowledgeable supervision.

Only one person at a time on the trampoline. Do not allow more than one person at the same time increases the chance of injury. Use trampoline only with mature, knowledgeable supervision. This trampoline is not recommended for children under 6 years of age.

WARNING

Do not attempt or allow somersaults. (Flips)

Do not land on head or neck. Landing on your head or neck can cause serious injury, paralysis, or death, even when landing in the middle of the mat. Use trampoline only with mature, knowledgeable supervision.

Do not allow more than one person on the trampoline.

Multiple jumpers increase the chance of loss of control, collision and falling off. This can result in broken head, neck, back or legs.

Use trampoline only with mature, knowledgeable supervision.

This trampoline is not recommended for children under 6 years of age.

Read all of the instructions before using this trampoline.

Inspect before using and replace any worn, defective or missing parts.

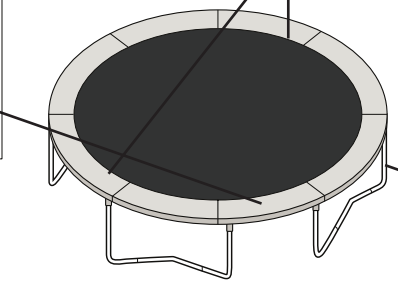

The labels shown on this page have been attached to the trampoline in the indicated locations. The Safety Instructions placard will need to be attached by the owner(see step 14). If one of the labels or the placard is missing or illegible, call our Customer Care Hot Line toll-free at 1-866-603-Jump(5867), Monday through Friday, 8 a.m. until 5 p.m. Mountain Time, to order a free replacement label or placard.

The placard shown at the right was sewn to the trampoline enclosure netting.

Note: The labels and placard shown are not actual size.

WARNING

Enclosure Safety Instructions

DO NOT land on head or neck. Paralysis, spinal cord injury, or death can result from a fall on the mat or the enclosure net. Use trampoline only with mature, knowledgeable supervision. Contact SEYOUNGER TRAMPOLINES for more information. This trampoline enclosure system is not recommended for use by children under 6 years of age.

Only one person at a time in the trampoline enclosure. Multiple jumpers increase the chance of loss of control and fall on or out of the enclosure netting. Use may become entangled in the trampoline enclosure netting. Use caution to avoid gaps between trampoline and enclosure.

For the Supervisor
Use trampoline enclosure only with mature, knowledgeable supervision. Contact SEYOUNGER TRAMPOLINES for more information. This trampoline enclosure system is not recommended for use by children under 6 years of age.

This trampoline enclosure system is not recommended for use by children under 6 years of age.

Do not exceed the weight limit recommended by the manufacturer.

Use only when the enclosure net is clean and dry. Inspect the trampoline and enclosure prior to each use and replace any worn or damaged parts.

Use only when the enclosure net has no holes, pulls, tears or rips, secured to the poles and the support frame, and the frame is properly supported.

For the Jumper
Do not use the trampoline when under the influence of drugs or alcohol.

Jumping
Avoid jumping too high or too long. Always control your jump. Do not try to jump over the bars.

Do not reach or lean out of the bars. Do not hang from, kick, cut or climb on the bars.

Wear clothing free of drawstrings, hoods, loops, or anything that could catch while using the trampoline enclosure and result in entanglement or strangulation on both.

Do not reach anything to the bars that is not a manufacturer approved accessory or part of the enclosure system.

Getting on and off
Climb on or out of the enclosure at the enclosure door or barrier opening. Do not jump on or off. Do not climb over the bars. Do not use the trampoline as a springboard to other objects.

Do not jump from other objects, buildings, or surfaces, onto the trampoline, or into or over the trampoline enclosure.

For further important information contact SEYOUNGER TRAMPOLINES. For all training information, contact a trampoline organization.

ATTACH TO NETTING AT DOOR

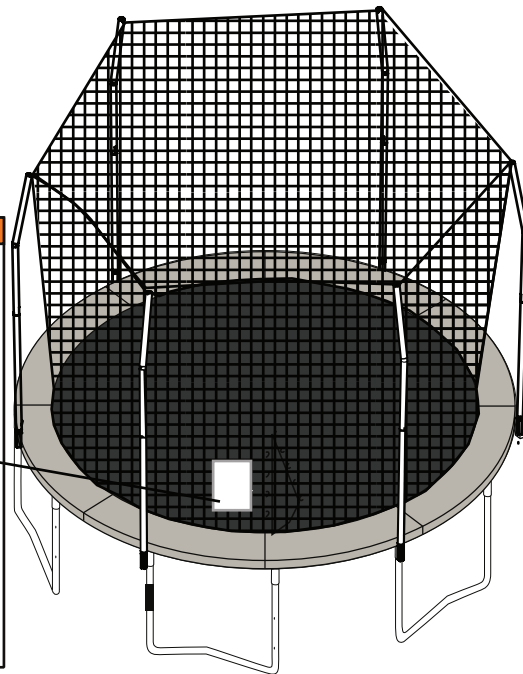

Specific use Limitations HIGH WIND

It is possible for the trampoline and enclosure to be blown about by high winds. If you expect high winds, move the trampoline and enclosure to a sheltered location. Disassemble(take down) the enclosure netting. Tie the trampoline frame down to the ground using ropes and stakes(not included). The only sure method to protect your trampoline and the surrounding environment during high winds is to completely disassemble the unit and store indoors.

BEFORE YOU BEGIN

Thank you for choosing your Skywalker Trampolines brand Trampoline. Skywalker Trampoline round Trampolines are designed and crafted to provide many years of fun and fitness. This trampoline comes equipped with warnings and instructions for the assembly, care, maintenance, and use of the trampoline. This information must be read by all trampoline supervisors and users before any person is allowed to jump on the trampoline.

If you have questions after reading this manual, please call our toll-free Customer Care Hot Line at 1-866-603-Jump(5867), Monday through Friday, 8 a.m. until 5 p.m. Mountain Time(excluding holidays). To help us assist you, please mention the model and name of the trampoline when calling. (See the inside cover of this manual.)



TRAMPOLINE SAFETY INFORMATION

In trampoline use, as in all active recreational sports, participants can be injured. However, there are steps that can be taken to reduce the risk of injury. In this section, primary accident patterns are identified and the responsibilities of supervisors and jumpers in accident prevention are described.

ACCIDENT CLASSIFICATION

Somersaults(flips): Landing on your head or neck, even in the middle of the trampoline mat, increases the risk of a broken back or neck, which can result in paralysis or death. Such events can occur when a jumper makes an error trying to perform a forward or backward somersault(flip). Do not perform somersaults(flips) on this backyard trampoline.

Multiple Jumpers: More than one jumper at a time on the trampoline increases the chance of a jumper becoming injured by losing control of his or her jump. Jumpers may collide with one another, fall off of the trampoline, fall onto or through the springs, or land incorrectly on the mat. The jumper weighing the least is the jumper most likely to be injured.

Mounting and Dismounting(Getting On and Off): The trampoline mat is several feet above ground level. Jumping from the trampoline to the ground or any other surface may result in injury. Jumping onto the trampoline from a roof, deck, or other objects also presents a risk of injury. Smaller children may need assistance getting onto or down from the trampoline. Climb carefully onto and off of the trampoline. Do not step onto the springs or the frame pad. Do not grasp the frame pad to pull yourself onto the trampoline.

Striking the Frame or the Springs: Injury may result from hitting the frame or falling through the springs while jumping or getting onto or off of the trampoline. Stay in the center of the mat when jumping. Be sure to keep the frame pad in place to cover the frame. The frame pad is not made or intended to support the weight of the trampoline user. Do not step or jump directly onto the frame pad.

Loss of Control: Jumpers who lose control of their jumps may land on the mat incorrectly, land on the frame or springs, or fall off of the trampoline. A controlled jump is one where the landing is in the same spot as the takeoff. Before learning a more difficult stunt, you should be able to do one before over and over with control. Attempting a stunt beyond present skill levels increases the chance of loss of control. To regain control and stop your jump, bend your knees sharply when you land.

Alcohol or Drug Use: The chance of injury increases when a jumper has consumed alcohol or taken drugs. These substances impair a person's reaction time, judgment, and physical coordination.

Encountering Objects: Jumping on a trampoline while other people, pets, or objects are underneath it will increase the chance of getting hurt. Jumping while holding or having an object on the trampoline, particularly one that is sharp or breakable, will increase the chance of injury. Placing a trampoline too close to overhead electrical wires, tree limbs, or other objects can increase the chance of injury.

Poor Maintenance of the trampoline: Jumpers may be injured if a trampoline is used when it is in poor condition. A torn mat, bent frame, broken spring, or missing frame pad, for example, should be replaced before anyone is allowed to jump. Inspect the trampoline before each use.

Weather Conditions: A wet trampoline mat is too slippery for safe jumping. Gusty or high winds can cause jumpers to lose control. To reduce the chance of injury, use the trampoline only when the weather is good.

Access: To prevent access to the trampoline by unsupervised smaller children, the optional access ladder should always be taken away and stored in a safe place when the trampoline is not in use.



ENCLOSURE SAFETY INFORMATION

NEED FOR TRAMPOLINE ENCLOSURE SAFETY

A trampoline enclosure is a recreational product.

The information on this page and on pages 7-9 identify important safety precautions. The precautions are not all-inclusive, because an enclosure can be used in ways that this manual cannot cover completely.

To prevent pinches and cuts during enclosure use, a frame pad must be installed on the trampoline (See the trampoline manufacturer's instructions). The frame pad must be placed on the trampoline before the enclosure is erected. The frame pad reduces the chance of injury from accidental contact with the springs and frame.

USING THE ENCLOSURE SAFETY

Adult Supervision of Children

Children using a trampoline with a trampoline enclosure must be supervised by adults. Young children must be supervised constantly. Adults must pay particular attention to:

- things that children bring into the enclosure.
- children's activities inside the enclosure.
- conditions inside the enclosure while children are using it.
- the way children enter and exit the enclosure.

Additional details of safety enclosure use are described below.

Electrocution Hazard Associated with the Metal Frame of the Trampoline and Enclosure

The trampoline and enclosure frames are made of galvanized steel. They are not grounded and will conduct electricity. For this reason, an electrocution hazard exists. No lights, electric heaters, extension cords, or household electrical appliances are to be permitted in or on the trampoline or enclosure at any time.

Hazards Associated with Entering and Leaving the Trampoline Enclosure

A trampoline enclosure installed on a trampoline is raised off the ground. The height of the enclosure increases the risk of a fall when a jumper is entering or leaving the enclosure. Young children, especially, may have difficulty entering and exiting the enclosure. To reduce the risk of falling, always help young children to get into and out of the enclosure.

Enter and exit the trampoline enclosure only through the door of the enclosure (the opening in the netting walls). The trampoline mat (bed) and the netting walls of the enclosure are separate pieces. No jumper, especially young children, should ever leave the enclosure by going out between the mat and the netting walls. Trying to get out this way creates a risk of choking from being caught between the trampoline frame and the netting walls.

Darkness increases the chances of a fall when a jumper is entering or leaving the enclosure. Do not use the trampoline unless there is plenty of lighting provided.

Hazards Associated with Animals, Sharp or Breakable Objects

To avoid damage to the trampoline enclosure and the trampoline, do not allow pets or other animals inside of the enclosure. The claws and teeth of animals can damage the netting. Do not jump on the trampoline while holding or wearing a sharp or breakable object.



METHODS OF ACCIDENT PREVENTION

The Supervisor's Role in Preventing Accidents

It is the responsibility of the supervisors of trampoline users to provide knowledgeable and mature supervision. They need to know and enforce all of the rules and warnings printed in this manual to minimize the likelihood of accidents and injuries. They also need to inform users of these rules. During periods of time when supervision is unavailable or inadequate, this may require that the trampoline is taken down, placed in a secure area, or otherwise secured against unauthorized use. Another option that may be considered is covering the trampoline with a heavy tarp that can be secured with locks and chains. It is the responsibility of the supervisor to make sure that the placard with TRAMPOLINE SAFETY INSTRUCTIONS (see step 14 in assembly instructions) is kept posted on the trampoline and that jumpers are informed about these instructions.

The Jumper's Role Preventing Accidents

Education on the part of the user is a must for safety. Users must first learn a low, controlled bounce and then learn the basic landing positions and combinations before proceeding to intermediate skills. Jumpers must understand why they have to master "control" before they can start thinking about other moves. Understanding the proper progression of skills in jumping on a trampoline must be the first lesson. Review this manual to learn about the basic techniques for using the trampoline. Follow the rules on the placard with TRAMPOLINE SAFETY INSTRUCTIONS (see step 14 in assembly instructions). For further information or additional instructional materials, contact a certified trampoline instructor.

TRAMPOLINE SAFETY INSTRUCTIONS

For the Supervisor

Read the instructions before using the trampoline. Enforce all of the safety rules. Become familiar with the information in this manual so you can help new users learn basic jumps and all users follow trampoline safety. All trampoline users must have mature, knowledgeable supervision, regardless of their skill or age. This trampoline is not recommended for use by children under 6 years of age. Inspect the trampoline before using it. Do not use the trampoline without the frame pad securely in place to cover the frame. Do not use the trampoline in wet or windy conditions. A worn or damaged mat, spring, or frame piece should be replaced immediately.

JUMPING

Learn fundamental jumps and body positions thoroughly before trying more advanced skills. Know your own limits in performing each of the trampoline jumps. Study this manual to learn how to do basic jumps.

Stop your bounce by flexing your knees as your feet come in contact with the trampoline mat. Learn this skill before attempting any others.



WARNING

Hazards Associated with High Winds

A trampoline with an enclosure can be moved or blown over by high winds. Anyone in its path, or inside of the enclosure, may be injured if this happens. If you expect high winds, take down the enclosure netting and stake the trampoline frame to the ground (see page 24), or move the trampoline and enclosure to a sheltered location. The only sure method to protect your trampoline and the surrounding environment during high winds is to completely disassemble the unit and store indoors. Damage due to wind or weather is not warranted.



WARNING

Storing the Trampoline Enclosure Safely

Specific steps for storing the trampoline enclosure are given later in this manual. There are special safety precautions to be aware of when storing the enclosure.

Remove the attached arch sections as a unit and place them on the ground. Separate the tubes after they are on the ground. Avoid pinching your fingers by wearing gloves and keeping your fingers away from pinch points near the bracket assembly while you are removing the tubes from the frame.

Placing the Trampoline and Enclosure in a Safe Place

There must be at least 24 feet(7.3 meters) of clear, open space above the ground. Do not place or store anything underneath the trampoline and enclosure. To avoid injury, the trampoline and enclosure must be kept away from objects and possible hazards including electric power wiring, tree limbs, and fences. Do not place the trampoline and enclosure near any other recreational devices or structures such as a swimming pool or swing set. The trampoline and enclosure must be placed on a level surface before use. The area around the trampoline must always have plenty of light.

For the Supervisor

- Be familiar with the information in this manual and enforce all of the safety rules. Help all users to utilize the trampoline and enclosure safely.
- All trampoline and enclosure users must have someone to supervise them at all times, regardless of the skill or age of the user.
- Secure the trampoline and enclosure against unauthorized and unsupervised use. Keep the trampoline and enclosure free of any objects that could interfere with the jumper.
- This trampoline and enclosure is not recommended for use by children under 6 years of age or by anyone weighing more than 200 pounds
- Use the trampoline and enclosure only when the trampoline mat (bed) is clean and dry. Inspect the trampoline and enclosure prior to each use and replace any worn or damaged parts. Use only when the enclosure netting has no holes, all uprights are tightly bolted into their sockets, and the netting is properly suspended.
- DO NOT attempt or allow somersault on the trampoline. Landing on the back or neck can cause serious injury, paralysis, or death, even when landing in the middle of the bed.

For the Jumper

Do not use the trampoline enclosure when under the influence of drugs or alcohol.

JUMPING

- Avoid jumping too high or for too long. Always control your jump.
- Take turns jumping one at a time, and always have someone watch you.
- Do not attempt to jump over the netting. Do not intentionally bounce off of the netting. Do not hang from, kick, cut, or climb on the netting.
- Wear clothing that does not have drawstrings, hooks, loops or anything else that could get caught while using the trampoline/enclosure and result in entanglement or strangulation, or both.
- Do not attach anything to the netting that is not a Skywalker Trampolines approved accessory or part of the trampoline enclosure.

GETTING ON AND OFF THE TRAMPOLINE

Climb onto and off of the trampoline. Do not jump onto or off of it. Do not use the trampoline as a springboard to jump to other objects or places.

ENTERING AND EXITING THE TRAMPOLINE ENCLOSURE

The Trampoline should be used only under the appropriate adult supervision.
A ZIPPER CLIP IS PROVIDED TO HELP SECURE THE TRAMPOLINE AGAINST UNSUPERVISED USE BY CHILDREN AND TO KEEP THE ZIPPER IN THE CLOSED POSITION DURING USE. A responsible adult supervisor should be present to assure that the zipper clip is attached to the D-ring on the jump mat and that the horizontal clips are attached to the D-rings on the enclosure netting, both during use and after use.

For additional information regarding equipment, contact Skywalker Holding, LLC. For additional information regarding skill training, contact a trainer certification organization.

USE AND INSTRUCTIONAL MATERIAL

OVERVIEW OF TRAMPOLINE USE

The first periods of trampoline use should focus on learning fundamental body positions and practicing the eight basic bounces that are described on pages 10 and 11.

During this learning period, jumpers should practice these basic techniques and perfect them. Braking, or checking the bounce, should be taught first and stressed as a safety measure. Jumpers should brake their jump whenever they start to lose their balance or control. This is done by simply flexing the knees sharply upon landing and absorbing the upward thrust of the mat. This allows the jumper to stop suddenly and avoid losing control.

With trampoline use, the takeoff point and landing point of a good, controlled jump are in the same spot. An exercise is considered learned only when a jumper is able to perform it correctly time after time. Jumpers should never go on to any advanced stunt until they can perform all previous stunts correctly each time.

Allow each jumper a brief turn on the trampoline. Extended bouncing exposes an overtired user to an increased risk of injury. Longer turns tend to lessen the interest of others waiting to jump. Clothing should consist of a T-shirt and shorts. Jumpers should wear regulation gymnastic shoes or heavy socks, or they may jump barefoot. Street shoes or tennis shoes should not be worn on the trampoline. Beginning jumpers may wish to wear loose-fitting protective clothes, such as a long-sleeve shirt and pants, until correct landings are mastered. This will reduce the chance of mat (bed) burns from improper landings on elbows and knees. No hard-sole shoes should be worn, as they cause extra wear on the trampoline mat.

Mounting and dismounting (getting on and off) properly should be a strict rule from the beginning. Users should climb onto the trampoline by placing their hands on the frame and stepping or rolling up onto the frame, across the springs, and onto the mat. They should not step directly on the frame pad or hold on to the frame pad when getting onto or off of the trampoline. Users should always place their hands on the frame while getting on or off. To get off, jumpers should walk to the side of the mat, bend over and place one hand on the frame, and then step from the mat to the ground. If you have installed the optional ladder, its rungs can be used to get on or off. Always face the ladder and place your hands on the frame. Make sure your foot has secure contact with the ladder rung when using it.

Reckless bouncing should not be permitted. All skills should be learned at moderate heights. Control, rather than height, should be emphasized. Jumpers should be forbidden to practice alone and unsupervised.

Instructional Program And Model Lessons

The following lessons are examples of an instructional program. They should follow a complete discussion and demonstration of body mechanics between the supervision and the student(s). See also page 12.

1. Mounting and dismounting (getting on and off)-Demonstration and practice of proper techniques.
2. Fundamental bounce-Demonstration and practice.
3. Braking (stopping the bounce)-Demonstration and practice. Braking on command.
4. Hand and knee drop-Demonstration and practice, stressing four-point landing and alignment.

Lesson 1: Fundamental Bounce

1. Start from a standing position with your head erect and your eyes on the frame pad.
2. Swing your arms forward and up in a circular motion.
3. Bring your feet together and point your toes downward while in the air.
4. Keep your feet about 15 inches apart when landing on the mat.

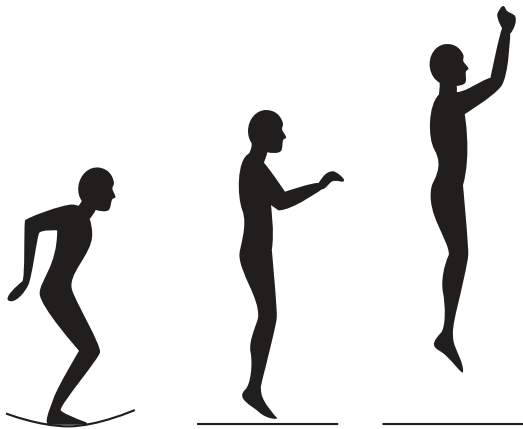

Lesson 2: Knee Drop

1. Review and practice of skills already learned.
2. Start bouncing from a standing position, keeping your eyes on the frame pad.
3. Land on your knees, keeping your back straight and your body erect.
4. Come back up to an erect position
5. Half twist to right, to the left, to the feet, and then to the knees.



Lesson 3: Hand and Knee Drop

1. Demonstration and practice, stressing four-point landing and alignment.
2. Start bouncing from a standing position, keeping your eyes on the frame pad.
3. Land on the mat on your hands and knees.
4. Push with your hands and come back up to an erect position.

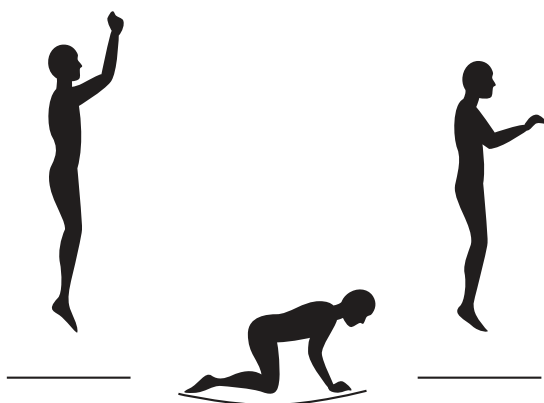

Lesson 4: Back Drop

1. Review and practice skills learned.
2. Start from a low bounce and land on your back.
3. Keep your chin forward on your chest as you land.
4. Kick forward and up with your legs to return to an erect position.
5. Demonstration, emphasizing the forward thrust of the hips by arching the body as one leg is brought forward from the standing (not bouncing) position, and the drop to the back with the chin held forward to the chest and the eyes forward on the frame pad. Spotting this skill is most important. Demonstration of back drop with low bounce and practice of both techniques.

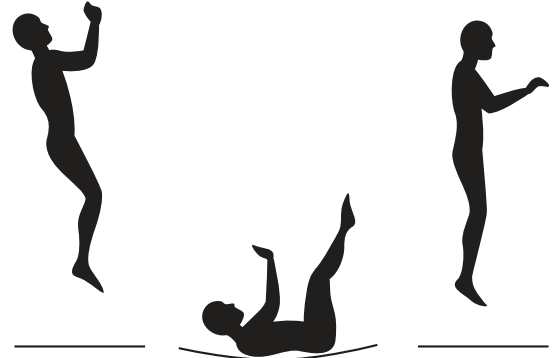

Lesson 5: Seat Drop

1. Review and practice of skills already learned.
2. Land in a sitting position with your legs parallel to the mat
3. Place your hands on the mat beside your hips.
4. Push with your hands to return to an erect position.
5. Half twist to the feet. Seat drop, knee drop, hand and knee drop, repeat.

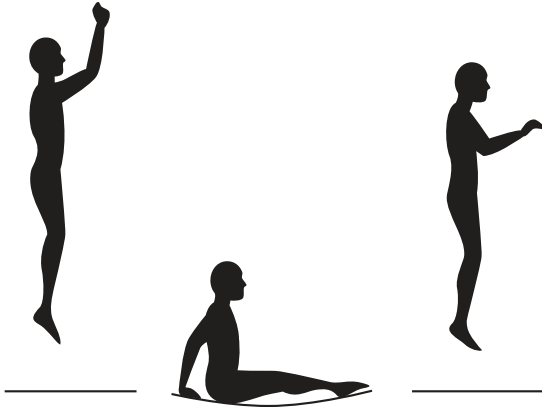

Lesson 6: Front Drop

1. To save time and avoid mat (bed) burns, all students should be requested to assume the front drop position on the floor while the instructor checks for faults. Suggested progression: from hand and knee bounce, the body is extended for the landing in the front drop position, and the rebound is made to the feet.
2. Start from a low bounce and land on the mat in a prone position.
3. Keep your head up and your arms extended forward on the mat.
4. Push with your arms to return to an erect position.

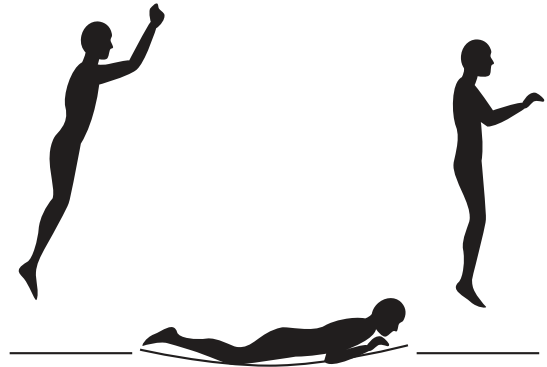

Lesson 7: Half Turntable

1. Review and practice of skills already learned.
2. Start from the front drop position and push to the left or right with your arms to begin turning your body in the opposite direction.
3. Turn your head and shoulders toward the direction that your body is turning.
4. Keep your back parallel to the mat and your head up.
5. After completing a half turn, land in the front drop position.

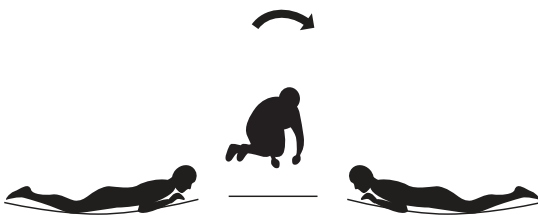

Lesson 8: Swivel Hips

1. Suggested progression: seat drop, feet, half twist, repeat; seat drop, half twist to feet, repeat; seat drop, half twist to seat drop.
2. Start with a seat drop.
3. Turn your head to the left or right and swing your arms up in the same direction.
4. Turn your hips in the same direction as your head and arms, completing a twist.
5. Land in the seat drop position.



Lesson 9

Once each of lessons are learned, the student should now be encouraged to design and organize routines, with emphasis on good form. The instructor may judge or grade students and arrange groupings for further instruction accordingly. To stimulate interest in competition, the game of "Trampoline Horse" can be introduced. Before the game begins, students must count off. To start the game, student number 1 performs a stunt. Student number 2 then mounts the trampoline, performs the same stunt and adds a second stunt. Student number 3 mounts and performs stunts 1 and 2 and adds a third stunt. Thus the series of stunts is continuously lengthened. The first person to miss a stunt in the series assumes the letter "H" and starts a new series with a stunt. If a person misses again, he assumes the letter "O." When a person accumulates "H-O-R-S-E," he or she is eliminated from the game. The last remaining contestant is the winner. Lesson planning from this point on should be facilitated by contacting a certified trampoline instructor.

Part Identification Chart (not to the actual scale) — Model No. JTEC12R

Use below drawings to identify all the parts.

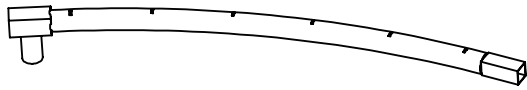

1 Top Tube with T-joint (6 pcs)



2 Top Tube with Socket (6 pcs)

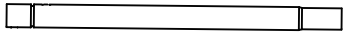

3 Leg extension (12 pcs)

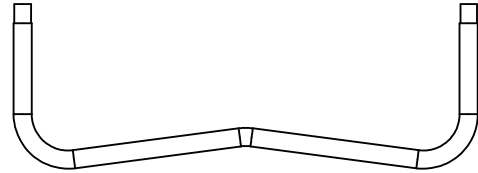

4 Leg brace (6 pcs)

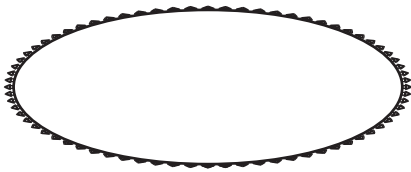

5 Jumping mat (1 pc)

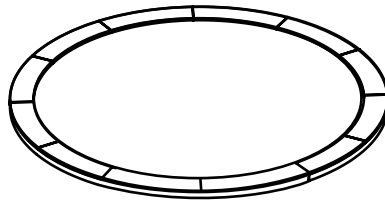

6 Frame PAD (1 pc)

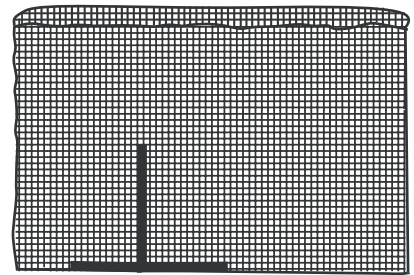

7 Enclosure net (1 pc)



8 Spring (72 pcs)



9 Straight Tube (6 pcs)



10 Curved Tube (6 pcs)

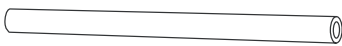

11 Foam (12 pcs)



12 Pole Cap (6 pcs)



13 End Cap (6 pcs)

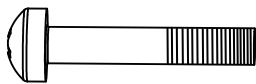

14 M5x50mm Bolt (6 pcs)



15 M4.8x16mm Self-tapping Screw(33 pcs), 3 spare parts

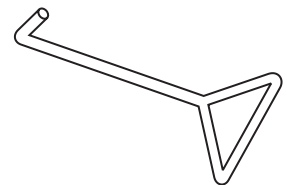

16 Spring Tool (1 pc)

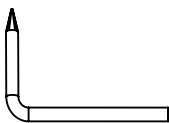

17 Screw Driver (1 pc)

Exploded Drawing — Model No. JTEC12R

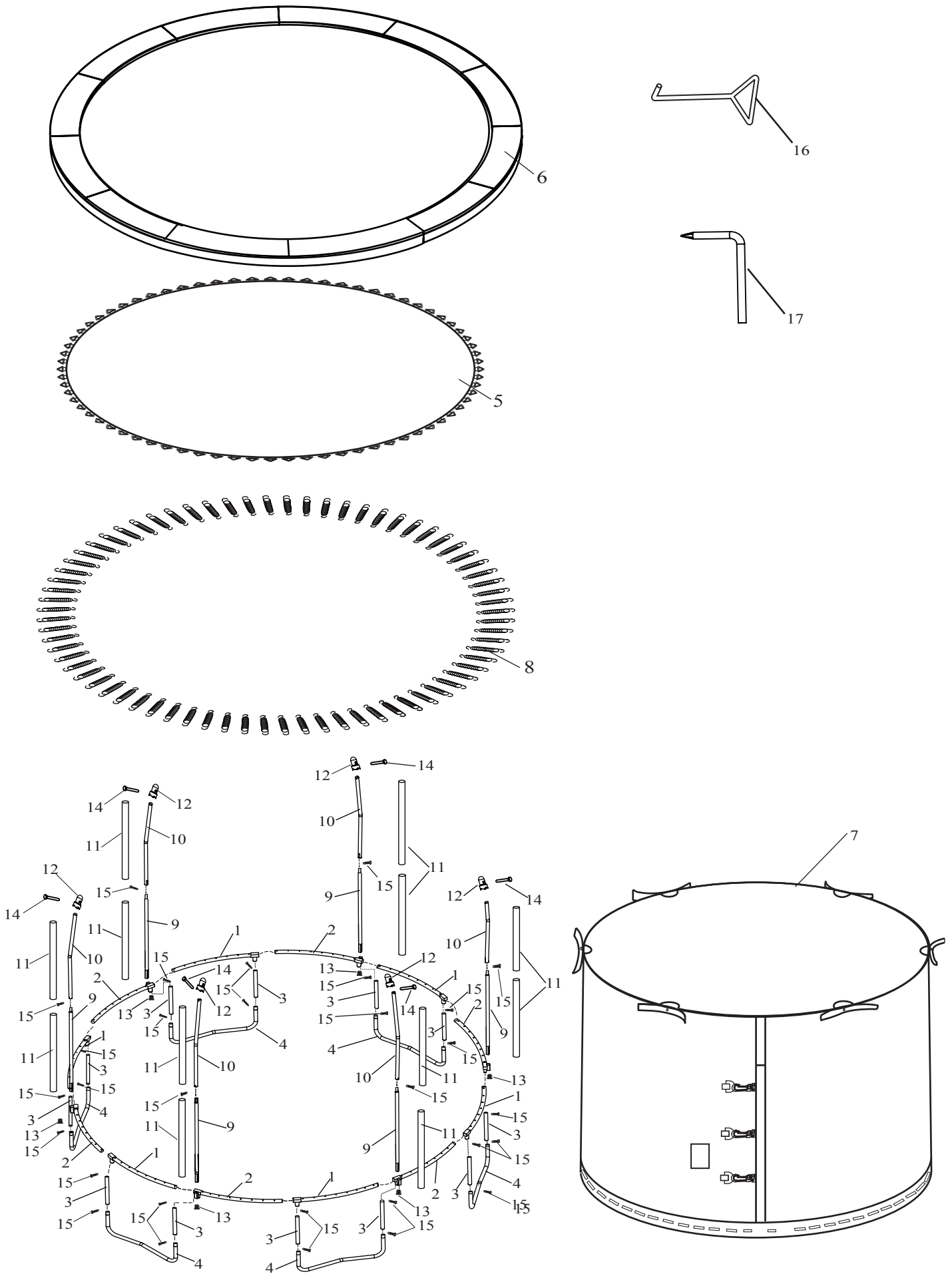

Part List — Model No. JTEC12R

Key No.	Qty.	Description
1	6	Top Tube with T-joint
2	6	Top Tube with Socket
3	12	Leg extension
4	6	Leg brace
5	1	Jumping mat
6	1	Frame PAD
7	1	Enclosure net
8	72	Spring
9	6	Straight Tube
10	6	Curved Tube
11	12	Foam
12	6	Pole Cap
13	6	End Cap
14	6	M5x50mm Bolt
15	33	M4.8x16mm Self-tapping Screw(3 spare parts)
16	1	Spring Tool
17	1	Screw Driver
#	1	User's Manual and Safety Placard
#	1	Set of ASTM Frame Labels

These parts are not illustrated.

Specifications are subject to change without notice.

ORDERING REPLACEMENT PARTS

To order replacement parts, visit our web site at www.skywalkertrampolines.com or call our toll-free Customer Care Hot Line at 1-866-603-Jump (5867), Monday through Friday, 8 a.m. until 5 p.m. Mountain Time (excluding holidays).

To help us assist you, please provide the following information when calling:

- the MODEL of the trampoline (see the front cover of this manual)
- the KEY NUMBER and DESCRIPTION of the part (see the PART LIST above)
- the quantity needed
- the desired method of shipping

ASSEMBLY

ASSEMBLY (PUTTING THE TRAMPOLINE AND ENCLOSURE TOGETHER)

IMPORTANT ASSEMBLY INFORMATION

- Need phillips screw driver (included with trampoline) and 2 adjustable wrenches (for putting the trampoline together). A rubber mallet is also recommended to make assembly easier.
- Assembly requires two adults. Keep children away from the trampoline and enclosure until they are completely put together.
- Use gloves to protect your hands from pinch points during assembly.
- Make sure that the trampoline is properly put together, with the frame pad correctly laid out, before you put together the trampoline enclosure.
- The assembly steps refer to parts by their descriptions and key numbers (see the PARTS LIST on page 14 and make sure that all listed parts are included. If a part is missing, refer to ORDERING REPLACEMENT PARTS at the bottom of page 14.

TRAMPOLINE PLACEMENT

1. Place the trampoline and enclosure on a level surface before you use it.
2. Adequate overhead clearance is essential. A minimum of 24 feet (7.3 meters) from the ground is recommended. Provide clearance from wires, tree limbs, and other possible hazards. Lateral (sideways) clearance is also essential. Place the trampoline and enclosure away from walls, structures, fences, and other play areas. Maintain a clear space on all sides of the trampoline and enclosure.
3. Use the trampoline in a well-lighted area. If the trampoline is indoors or in a shady areas you may need to use artificial (electrical) lighting in the area.
4. Secure the trampoline and enclosure against unauthorized and unsupervised use.
5. Remove any objects from under the trampoline and enclosure.
6. The owner and supervisors of the trampoline are responsible to make all users aware of practices specified in this manual.
7. The trampoline enclosure is only to be used as an enclosure for a specific round trampoline.

Trampoline and Enclosure Assembly

To make assembly easier, read the assembly tips at the top of this page.

1. Locate the Top tube with T-joint(1) and the Top tube with Socket(2) as shown.

NOTE:

Make sure all the spring holes are facing ground.

NOTE:

If you don't assemble in the right order, you will have to disassemble the entire trampoline in order to attach correctly.

Identify the T-joint and Socket shown in right will be helpful for you, they are pre-installed on Top tube.

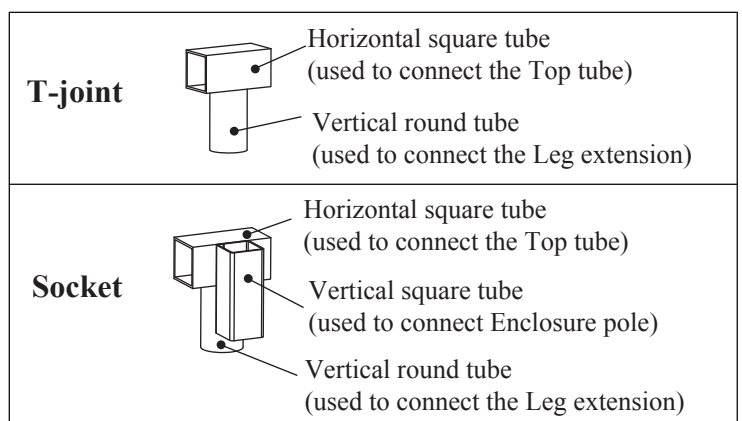
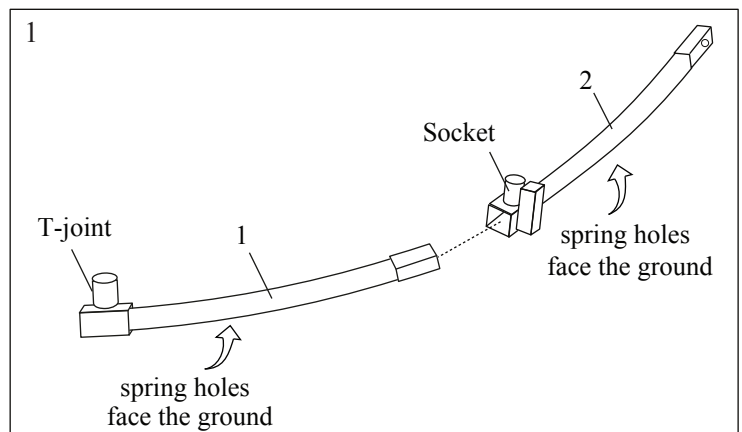

2. Insert the Leg Brace(4) into two Leg Extensions(3) as shown, then tighten with two M4.8x16mm Self-tapping screws(15).

Press down on both Leg Extensions(3) at the same time and fully insert them into the T-joint and Socket, then tighten by two M4.8x16mm Self-tapping screws(15).

Repeat above assembly steps until six frame pieces are completed.
then flip the trampoline frame pieces over so that the legs are now holding the trampoline frame pieces up.

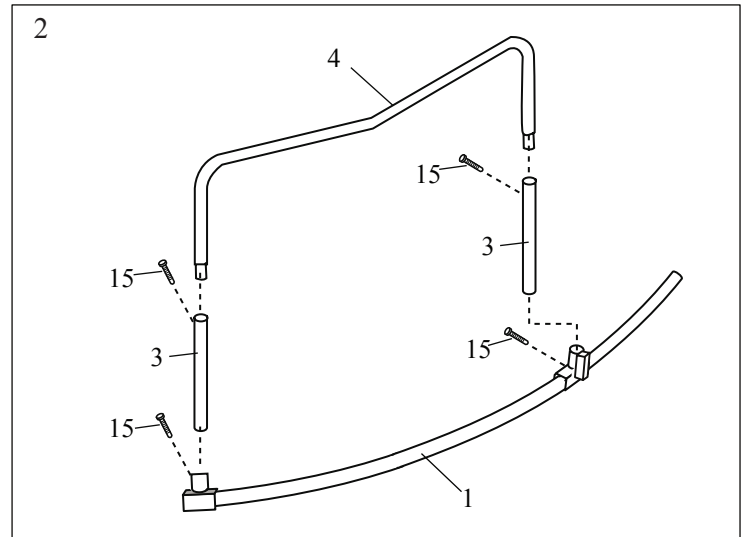

3. Locate two frame pieces as shown and then fully connect them together.

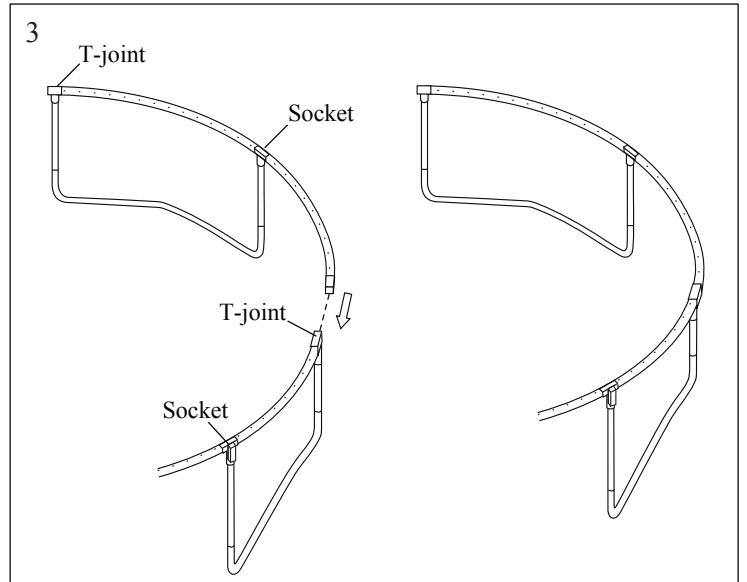

Repeat above step 3 in the same way, you should now have a free standing frame as shown.

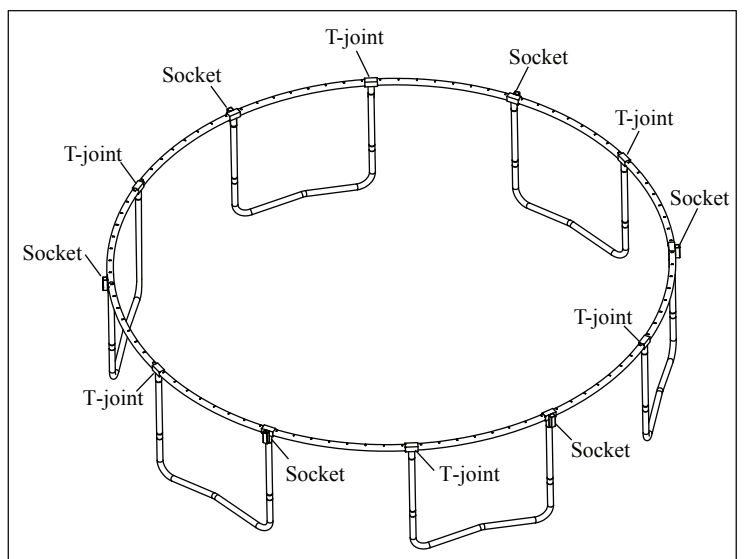

4. If the Enclosure net(7) and Jumping mat(5) are not pre-installed, follow below steps to install.

4.1 Place the Jumping mat(5) on clear ground. Identify the warning label on mat top and the ID label on mat back as shown.

4.2 Place the Enclosure net(7) on the Jumping mat(5), make sure the first hole and the first V-ring are aligned as shown.

4.3 Insert the first V-ring into the first hole, and then insert the remaining V-rings into corresponding holes in the same way one by one, until the Enclosure Net(7) and the Jumping mat(5) are fully attached .

NOTE:

The first hole refers to the first one that is located just left of the Enclosure door.

The first V-ring refers to the one that is located just left of the warning label near the ID label on Jumping mat.

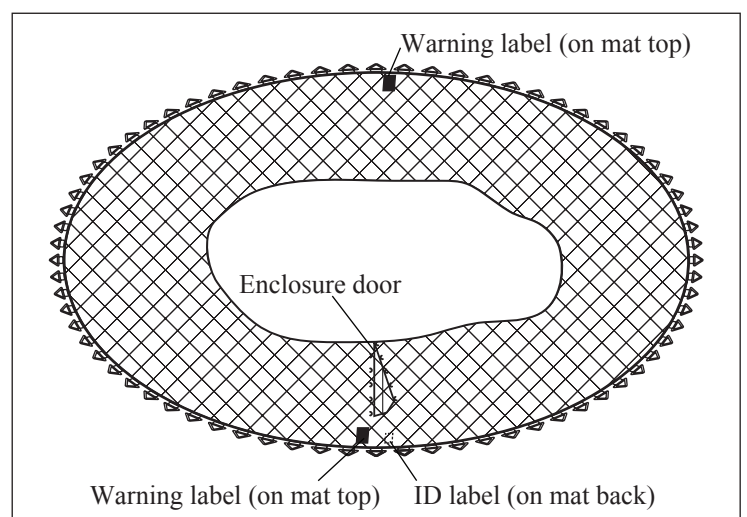
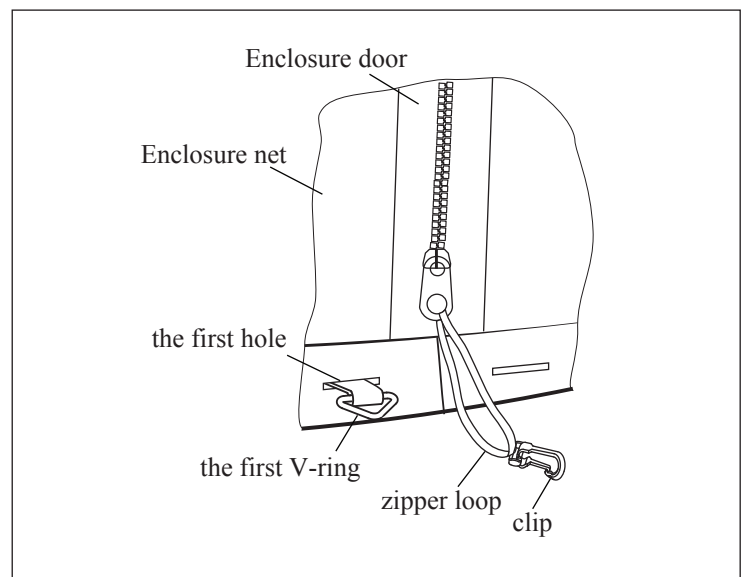
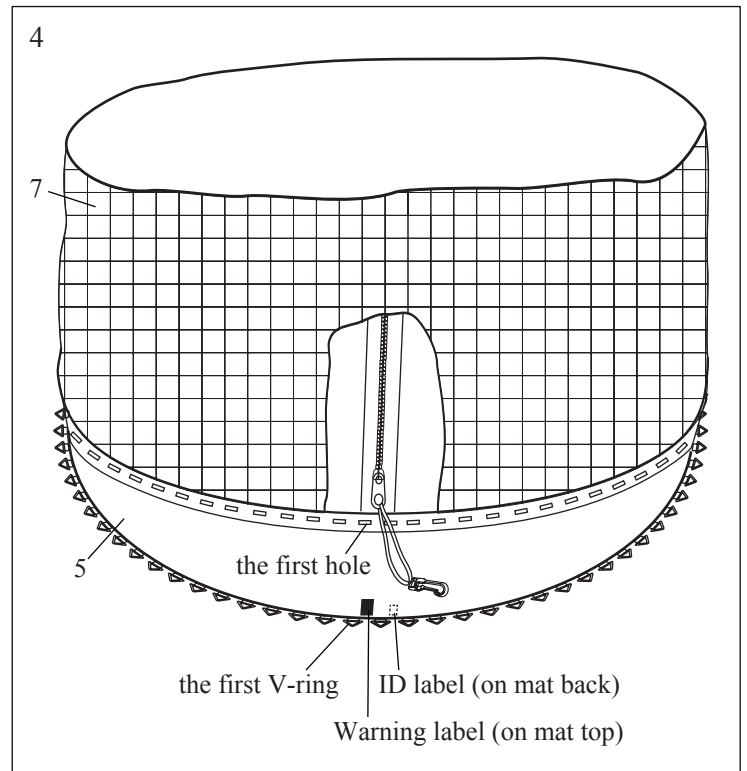

5. If the Enclosure net and Jumping mat are pre-installed, follow below steps to assemble the Jumping mat to frame.

5.1 Inspect the connection of Jumping mat and Enclosure net, make sure all the V-rings are passed through the corresponding net holes.

5.2 Place the Jumping mat(5) on clear ground inside the frame. and then adjust the location of two warning decals to align the two T-joint in opposite direction as shown.

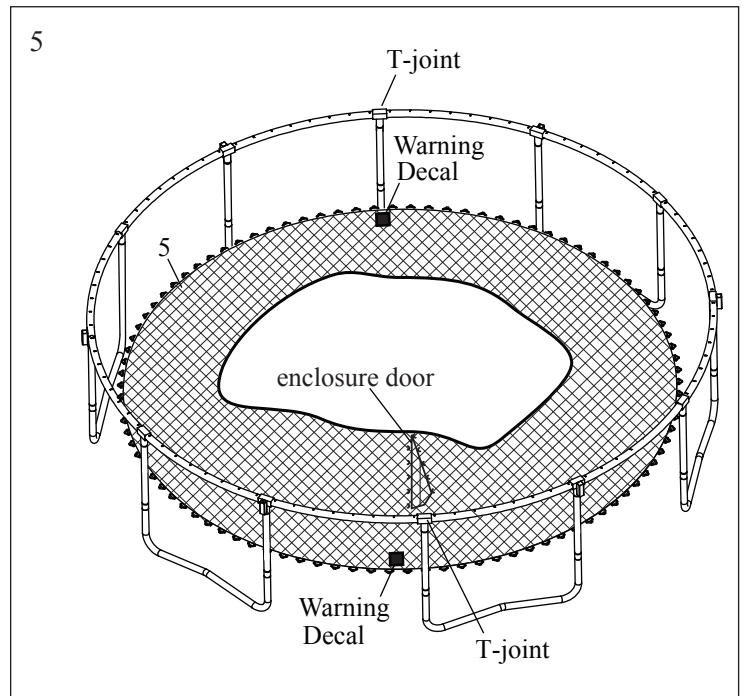

5.3 Attach the first V-ring with a spring to the first spring hole on left side of T-joint, and then attach the opposite V-ring to the first spring hole on left side of T-joint.

NOTE:

Count exactly the quantity of V-rings and the spring holes on frame top, make sure each of them are corresponding.

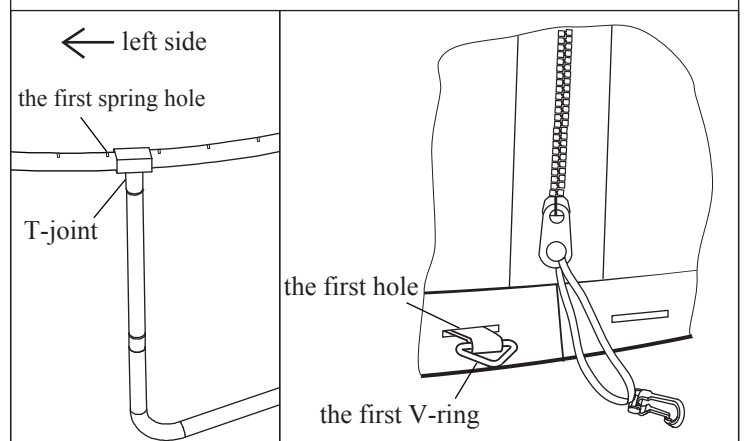
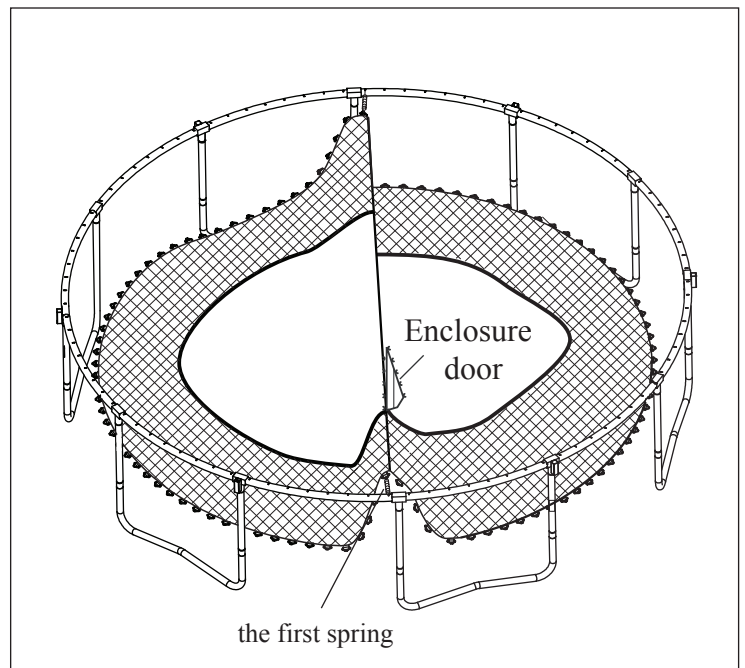

Attach the Spring as follows:

- A: Hook one end of Spring into the V-ring sewn on Jumping mat.
- B: Hook a Spring Tool as shown to the free end of the Spring.
- C: Pull the Spring until it reaches the frame.
- D: Push the end of the Spring into a hole in the frame, then unhook the Spring Tool

CAUTION:

It is wise to wear leather gloves while attaching the springs. Be careful where you place your hands as the Springs and Frame joints can pinch.

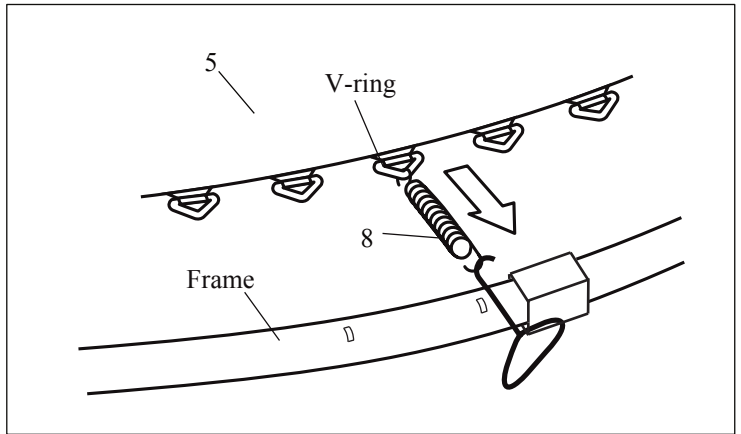

- 5.3 Attach another two lateral V-rings to frame holes in the same way as 5.2

NOTE:

Count exactly the quantity of V-rings and the spring holes on frame top, make sure each of them are corresponding.

NOTE:

There are 72 springs around the edge of Jumping mat(5) and 72 holes around the top tube.

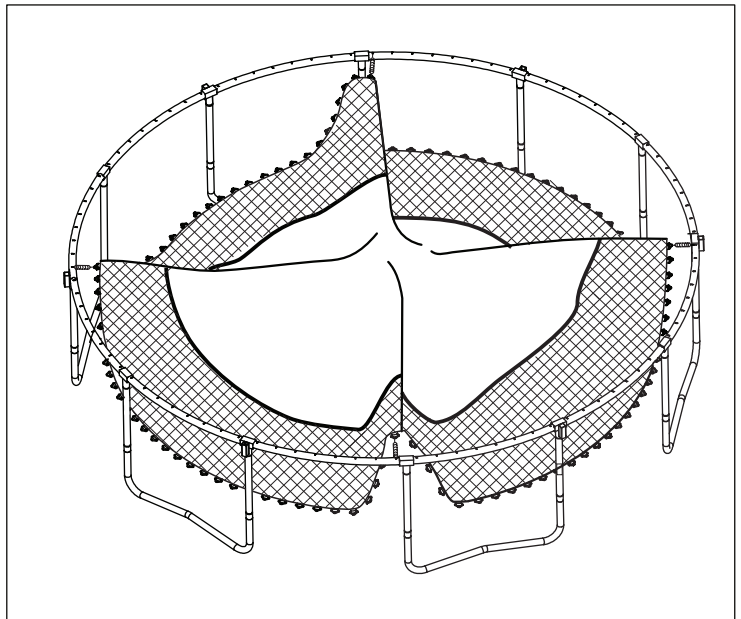

- 5.4 Attach other V-rings to frame holes on left side of T-joint or Socket in the same way as 5.2

Now there are 12 V-rings are attached to the Top tube. And 12 Springs have been used.

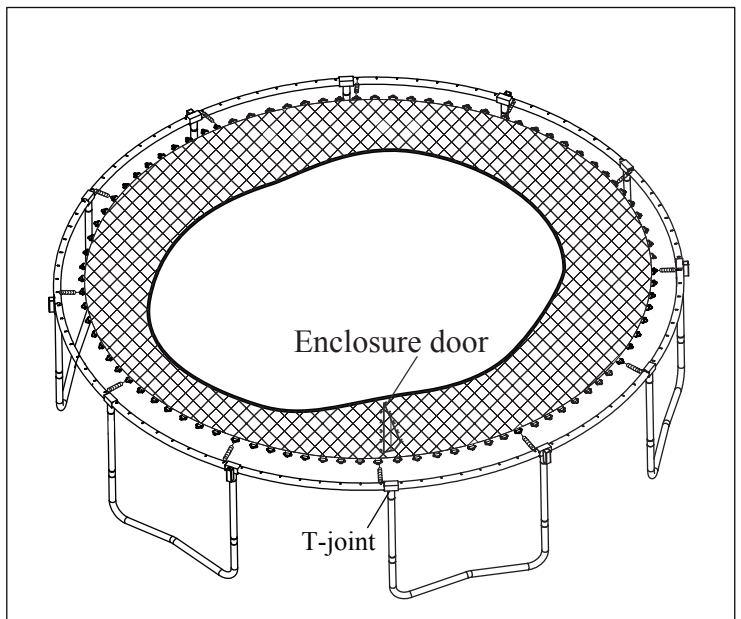

- 5.5 Attach all the remaining V-rings with spring to Top tube holes correspondingly.

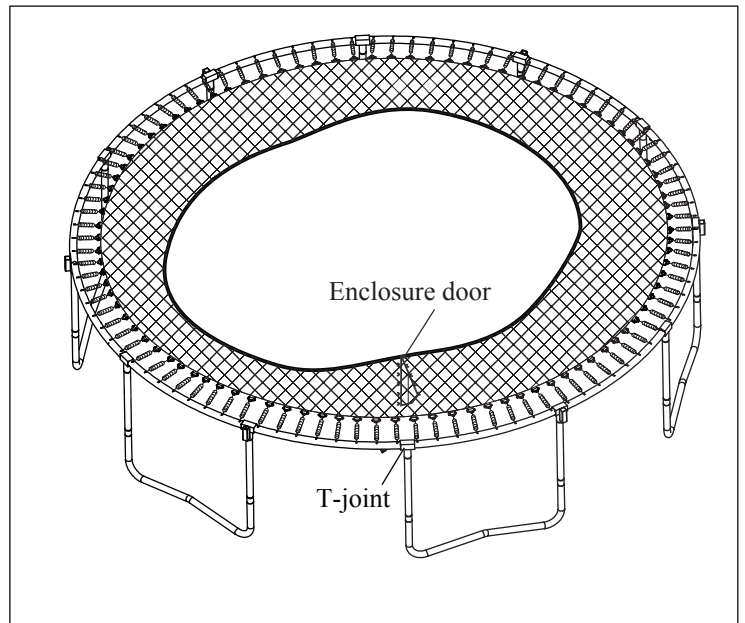

6. Lay the Frame PAD(6) on the frame. Adjust it's position so that the slits are just above the Sockets as shown.

CAUTION:

Do not use the trampoline without the Frame Pad(6). The Frame Pad is designed to reduce the possibility of injuries due to jumpers coming in contact with the trampoline frame. If you do not have a Frame Pad, contact your dealer to obtain one. Properly install the Frame Pad before using the trampoline.

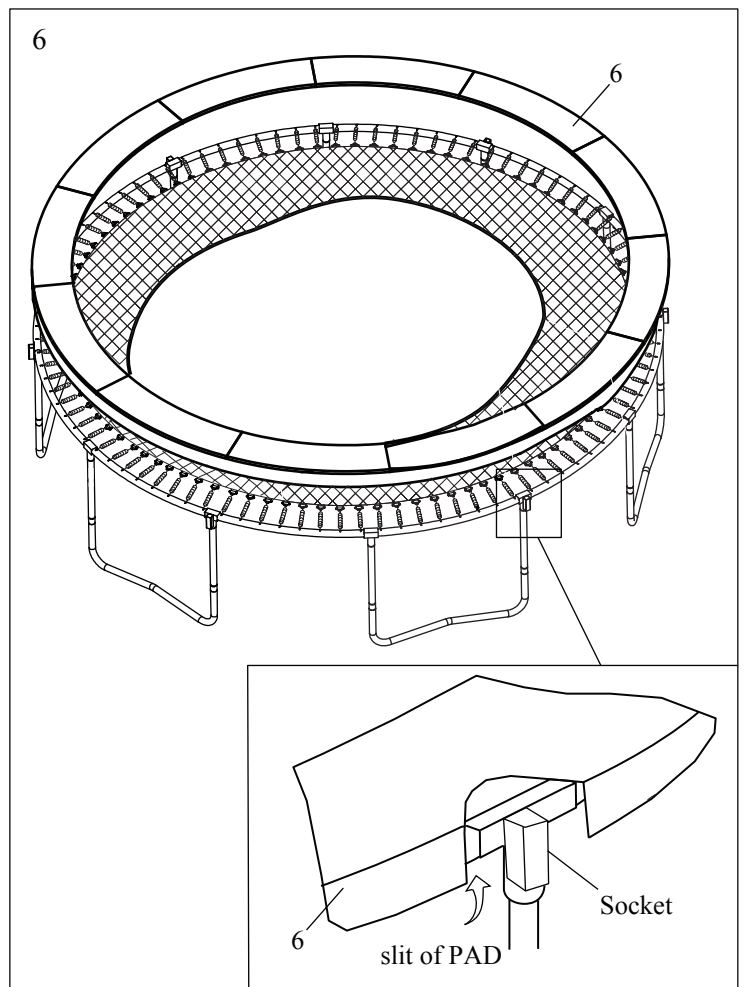

- Look underneath the trampoline. Locate the straps attached to the underside of the Frame PAD. Position each outer strap so that one strap is on each side of the frame as shown. Tie the outside straps sewn to the PAD Joints to each side of the frame as shown and attach the inner straps to the near V-rings.

Repeat this step to tie the remaining straps (not shown).

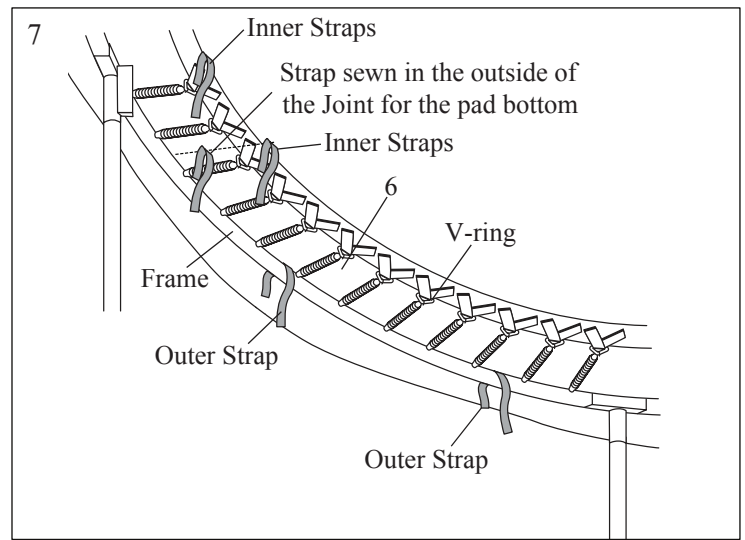

- Slide the Straight Tube(9) and Curved Tube(10) into Foams (11) as shown.

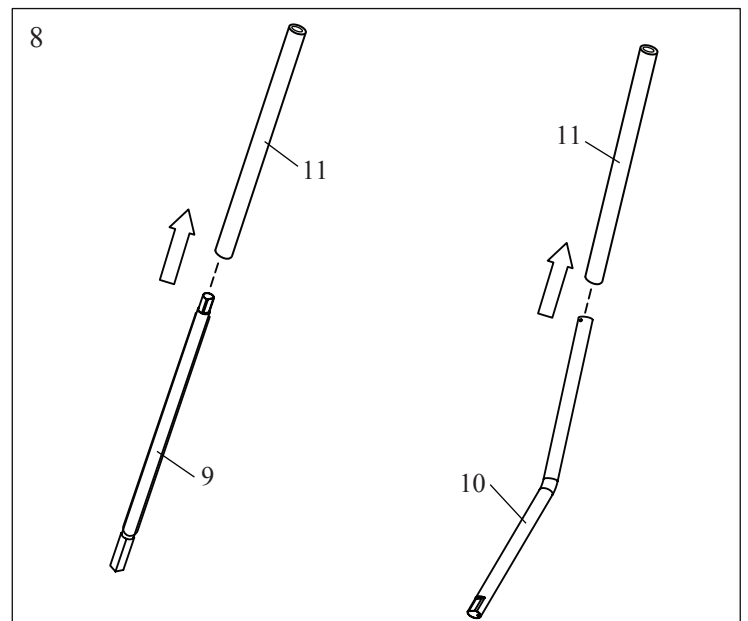

- Lay one Straight Tube(9) with Foam and one Curved Tube(10) with Foam on the ground. Insert the Straight Tube(9) into the Curved Tube(10). Secure with a M4.8x16mm Self-tapping screw(15)

Repeat this step to attach the five remaining Straight Tubes(9) and Curved Tubes(10) together (not shown).

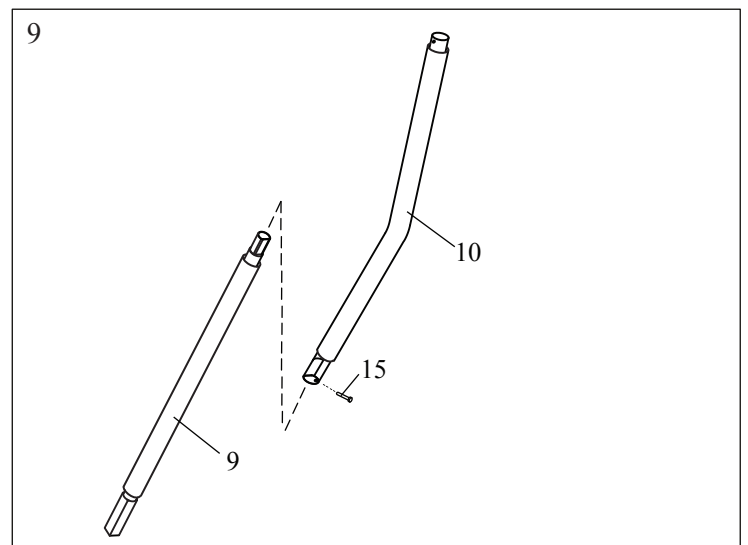

10. Follow below steps to attach Curved tube to cap

- A.
Identify the hexagon hole on the Pole Cap(12) with a nut buried inside.
- B.
Insert the Pole Cap(12) into one strap ring on the top edge of net.
Make sure the Hexagon hole side of the cap is against the net, and the holes on both the strap ring and the caps are aligned.
- C.
Hold the pole cap close to a Curved Tube(10), then Insert the Curved Tube(10) into the Pole Cap(12).
Make sure the holes on the curved tube, pole cap and strap ring are aligned. then Insert the M5x50mm bolt(14) until it touches the nut in the Hexagon hole of the pole cap, securing them together.

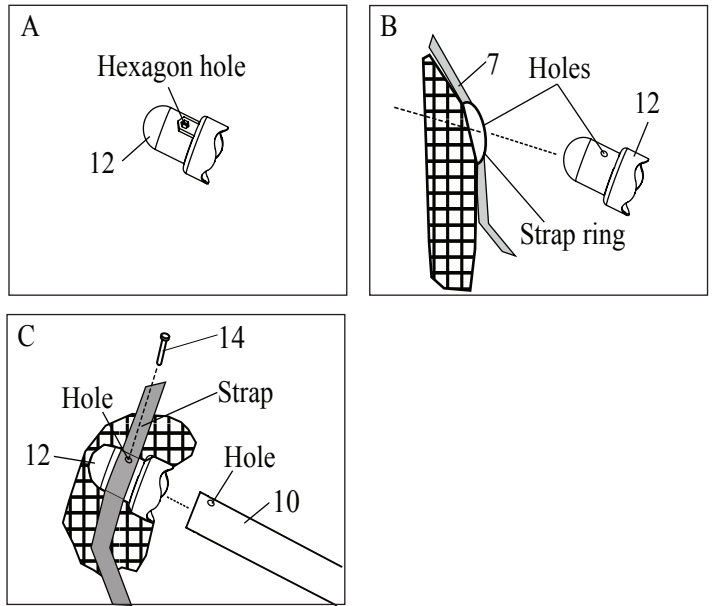

Repeat this step to assemble the remaining parts in the same way.

11. Start from the Enclosure door, lift one of the assembled poles and then insert the Straight Tube(9) into the vertical tube of Socket as shown.

Make sure the bent side of the enclosure poles are facing toward the center of the trampoline.

NOTE:
The end of the Straight Tubes(9) are sharp. be careful when assembling.

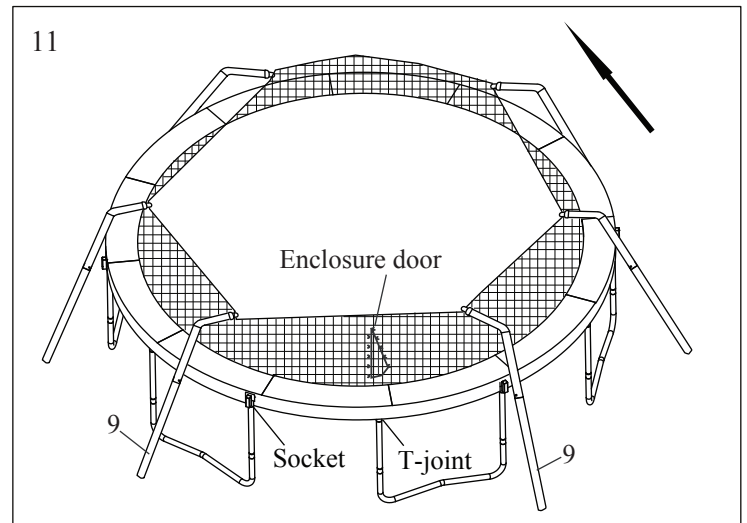

Repeat this process to assemble the remaining five poles to the trampoline frame.

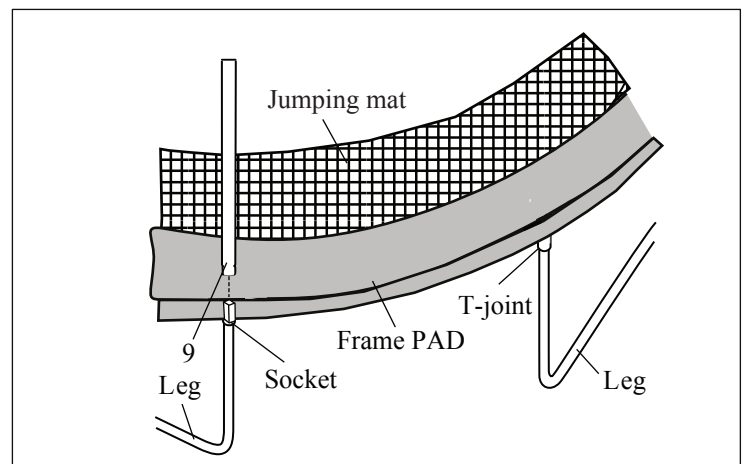

12. Insert the end cap(13) into the bottom hole of the Socket as shown.

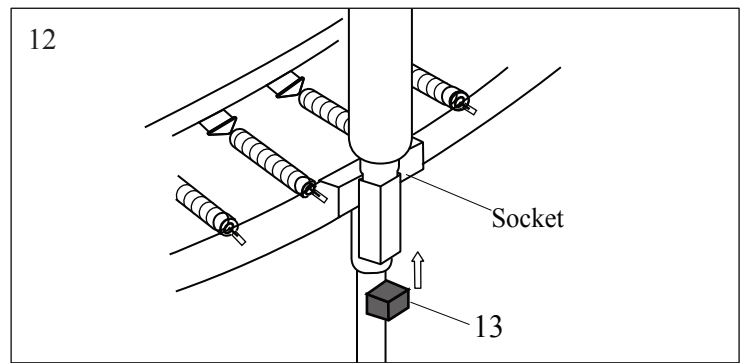

13. Using a ladder, reach to the top of the enclosure poles and tie the straps around the pole caps as shown. Make sure to secure the knot tightly. (Do not stand on the edge of the trampoline to do this step. It can be dangerous and could damage the trampoline).

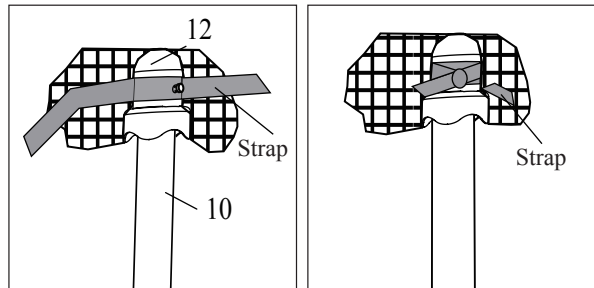

14. Using the included plastic tie, attach the Safety Placard to the frame near the point where jumpers will climb onto and off the trampoline.

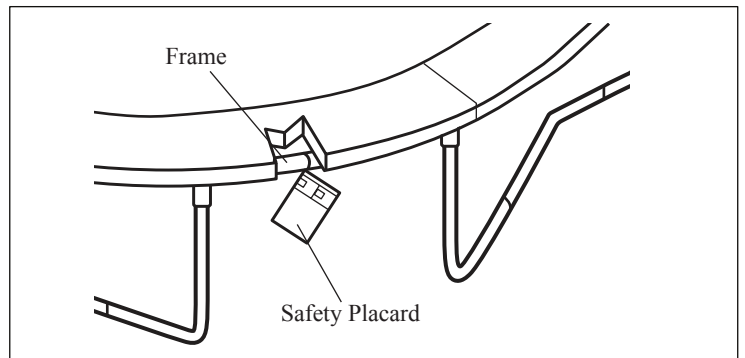

Your trampoline and enclosure are fully assembled now.

Make sure that all parts are securely attached. Familiarize yourself and all users with the trampoline and enclosure with the safety precautions, use and instructional materials, and care and maintenance instructions in this manual before using the trampoline and enclosure.

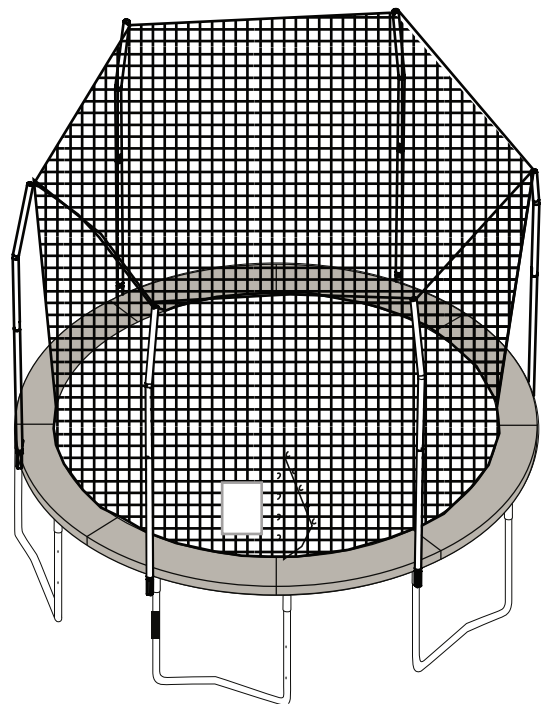

Disassembly

To disassemble the enclosure and trampoline, follow assembly steps 1 through 11 in reverse order.

Replacing the Enclosure net

If your Enclosure net is damaged after using a period of time, you need to replace it by following assembly steps 4-7 and 10-13 in reserve order.



WARNING

Trampoline And Enclosure Care And Maintenance

Care

To avoid damage to the trampoline and enclosure, do not allow pets or animals inside the enclosure.

The trampoline is intended to be used by one person at a time who weighs no more than 200 pounds. The user should be either barefoot, wearing socks, or wearing gymnastic shoes. Street shoes or tennis shoes should not be worn on the trampoline. The user should remove all sharp objects from his or her person that may cause injury or damage to the mat. Heavy, sharp, or pointed hard objects should never touch the mat.

Continued exposure over a long period of time to the sun, especially to ultraviolet rays, will shorten the life of the enclosure fabric. For longer fabric life, store the enclosure when it is not being used. A dry enclosure, properly stored, will provide the longest life of the fabric, sewing, and hardware. Remove the enclosure from the trampoline during harsh weather conditions or during long periods of non-use.

Maintenance

Your trampoline was manufactured using quality materials and crafted to provide you and your family with many years of enjoyment and exercise. Proper maintenance and care will help to prolong the life of the trampoline and reduce the possibility of injury. The following guidelines should always be followed.

Inspect the trampoline enclosure before each use, and replace any worn, defective, or missing parts. The following conditions could represent potential hazards and increase the danger of personal injury:

- missing, improperly positioned, or insecurely attached frame padding, netting, enclosure tubes, or foam sleeves
- punctures, frays, tears, or holes worn in the mat, frame padding, netting or foam sleeves
- deterioration in the stitching or fabric of the mat, frame padding or netting
- ruptured or missing springs
- bent or broken frame, leg or enclosure tubes
- sagging bed or netting
- sharp protrusions on the frame, suspension system or enclosure tubes

If any of these conditions exist, the trampoline and/or enclosure should be disassembled (taken apart) or otherwise protected from being used until the condition is fixed.

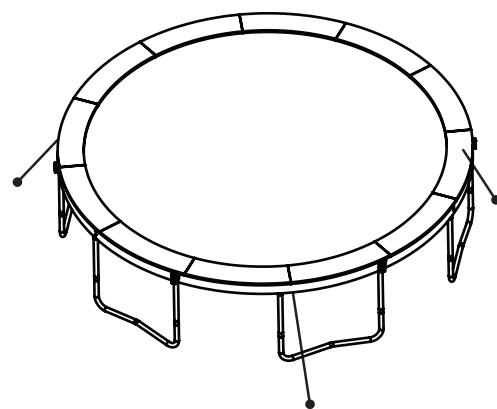

Special Considerations

High Wind

It is possible for the trampoline and enclosure to be blown about by high winds. If you expect high winds, move the trampoline and enclosure to a sheltered location. Disassemble (take down) the enclosure netting. Tie the trampoline frame down to the ground using ropes and stakes(not included). At least three ropes and three stakes should be used. Make sure to attach the ropes to the top of the trampoline frame, do not simply secure the legs or the bases to the ground as they can separate from the frame sockets. The tops of the stakes should be at ground level so that they will not create a tripping hazard. In addition, the tops of the stakes should be covered, if necessary, so that users will not be hurt by falling onto the stakes.

Moving the Trampoline and Enclosure

If the trampoline and enclosure needs to be moved, it should be moved by two persons, kept horizontal, and lifted slightly. If necessary, the trampoline and enclosure can be taken apart for moving. To take the trampoline apart, follow the assembly steps in reverse order(see page 15 to 23). Do not attempt to take the frame sections, legs, or bases apart before the mat and springs have been removed.

Limited Warranty

Skywalker Holdings, LLC warrants its trampoline products to be free from defects in material and workmanship under normal use and service conditions. The steel frame is warranted for one(1) year after the date of purchase. All other parts are warranted for ninety(90) days after the date of purchase. Wind or weather damage is not warranted.

All warranty coverage extends only to the original retail purchaser from the date of purchase. Skywalker Holdings, LLC obligation under this Warranty is limited to replacing or repairing, at Skywalker Holding, LLC option, the product at one of this authorized service centers. All products for which a warranty claim is made must be received by Skywalker Holdings, LLC at one of its authorized locations. Preauthorization may be obtained by calling Skywalker Holding, LLC Customer Care Hot Line at 1-866-603-Jump(5867). This Warranty does not extend to any product or damage to a product caused by or attributable to freight damage, abuse, misuse, improper or abnormal usage, or repair not provided by a Skywalker Holdings, LLC authorized service center, or to products used for commercial or rental purpose. No other Warranty beyond that specifically set forth above is authorized by Skywalker Holdings, LLC.

SKYWALKER HOLDINGS, LLC IS NOT RESPONSIBLE OR LIABLE FOR INDIRECT, SPECIAL OR CONSEQUENTIAL DAMAGES ARISING OUT OF OR IN CONNECTION WITH THE USE OR PERFORMANCE OF THE PRODUCT OR OTHER DAMAGES WITH RESPECT TO ANY ECONOMIC LOSS, LOSS OF PROPERTY, LOSS OF REVENUE OR PROFITS, LOSS OF ENJOYMENT OR USE, COST OF REMOVAL, INSTALLATION OR OTHER CONSEQUENTIAL DAMAGES. SOME STATES DO NOT ALLOW THE EXCLUSION OR LIMITATION OF INCIDENTAL OR CONSEQUENTIAL DAMAGES. ACCORDINGLY, THE ABOVE LIMITATION MAY NOT APPLY TO YOU.

THE WARRANTY EXTENDED HEREUNDER IS IN LIEU OF ALL OTHER WARRANTIES AND ANY IMPLIED WARRANTY OF MERCHANTABILITY OR FITNESS FOR A PARTICULAR PURPOSE IS LIMITED IN ITS SCOPE AND DURATION TO THE TERMS SET FORTH HEREIN. SOME STATES DO NOT ALLOW LIMITATIONS ON HOW LONG AN IMPLIED WARRANTY LASTS. ACCORDINGLY, THE ABOVE LIMITATION MAY NOT APPLY TO YOU. This Warranty gives you specific LEGAL RIGHTS. You may also have other rights which vary state to state.

THIS WARRANTY IS VALID ONLY IN THE UNITED STATES.

Skywalker Holdings, LLC, PO Box 574, Brigham City, UT 84302 USA.

Printed in China © 2014 Skywalker Holdings, LLC,