

Hornady[®]
Accurate. Deadly. Dependable.



OWNER'S MANUAL

LOCK-N-LOAD[®]
POWER
CASE PREP
CENTER

Lock-N-Load® Power Case Prep Center

PARTS LIST

Item No.	Production Part No.	Qty.	Description
1	399117	1	Power Trimmer Handle
2	399142	1	Handle Trimmer Left
3	399133	1	Nut Spindle Stop
4	399128	1	1/4" Steel Ball
5	399141	1	Handle Trimmer Right
6	399113	1	Spindle Return Spring
7	399112	1	Trimmer Spindle
8	399119	2	Spindle Support Guide Rod
9	399136	6	Button Head Cap Screw (BHCS) 8-32 X 1/2
10	399116	1	Power Trimmer Spindle Support
11	399134	1	Spindle Locking Bolt
12	399121	1	Case Lock Power Trimmer
13	399135	1	Handle Pin
14	399122	1	Case Lock Plunger
15	380053	1	Spring Shell Holder Ram
16	399123	1	O-Ring
17	398219	1	Cam-Lock Handle Shell Lock
18	399126	1	Power Trimmer Chip Catcher
20	399153	6	Gear and Shaft Assembly
21	399152	1	Drive Gear and Shaft Assembly
22	399154	2	Idler Gear and Shaft Assembly
23	399131	10	Flange Bushing, 3/8" ID
24	399138	4	Socket Head Cap Screw (SHCS) 10-24 X 1¼
25	399100	1	ID Chamfer Tool
26	399101	1	OD Chamfer Tool
27	399107	1	Case Prep Chip Catcher
28	399108	1	Case Prep Cover
30	399143	3	Button Head Cap Screw (BHCS) 10-32 X 1/2
31	390651	1	Flat Washer, 3/16 SAE, Zinc
32	398218	1	Handle Trimmer
33	399129	1	Lead Screw Micro Adjust
34	391014	1	Screw Socket Set, 10-32 X 3/16

Item No.	Production Part No.	Qty.	Description
35	399110	1	Power Trimmer Frame
36	399132	1	Flange Bushing 1/2" ID
37	399120	1	Lead Screw Power Trimmer
38	399130	1	Knob, 1/4-20
39	399139	1	Washer Wave, 1/4" ID X .010 THK.
40	399114	1	Spindle Lock Power Trimmer
41	398332	1	Switch
42	390972	1	Cam-Lock Trimmer Cutter
43	392011	2	Hex Nut, 10-32
44	399111	1	Power Trimmer Motor Cover
45	399124	1	Motor
46	399115	1	Power Trimmer Cutter Spindle
47	399147	1	Washer, .036 THK., Steel
48	399148	1	Spring, Curved
49	392426	1	Roll Pin, 1/8 X 1/2
51	399149	1	Washer, .020 THK., Steel
53	399125	4	Motor Stand Off
54	399109	2	Motor Gear
55	399150	1	Washer, .010 THK., Steel
56	399140	4	Socket Head Cap Screw (SHCS) 8-32 X 2¼
-	380063	1	Case Neck Brush, 22 Cal.
-	380065	1	Case Neck Brush, 25 Cal./6MM
-	380066	1	Case Neck Brush, 270 Cal./7MM
-	380067	1	Case Neck Brush, 30 Cal.
-	380068	1	Case Neck Brush, 35 Cal.
-	380069	1	Case Neck Brush, 45 Cal.
-	398241	1	Pilots Trimmer 7 Pkg.
57	399185	1	E-Clip, 5/16
58	392306	1	Pin Dowel, 1/8 X 1/2
59	399179	1	Motor Mount
60	398837	2	Pan Head Screw 8 X 3/4
61	398838	2	Pan Head Screw 8-32 X 1/4

Lock-N-Load® Power Case Prep Center

EXPLODED VIEW

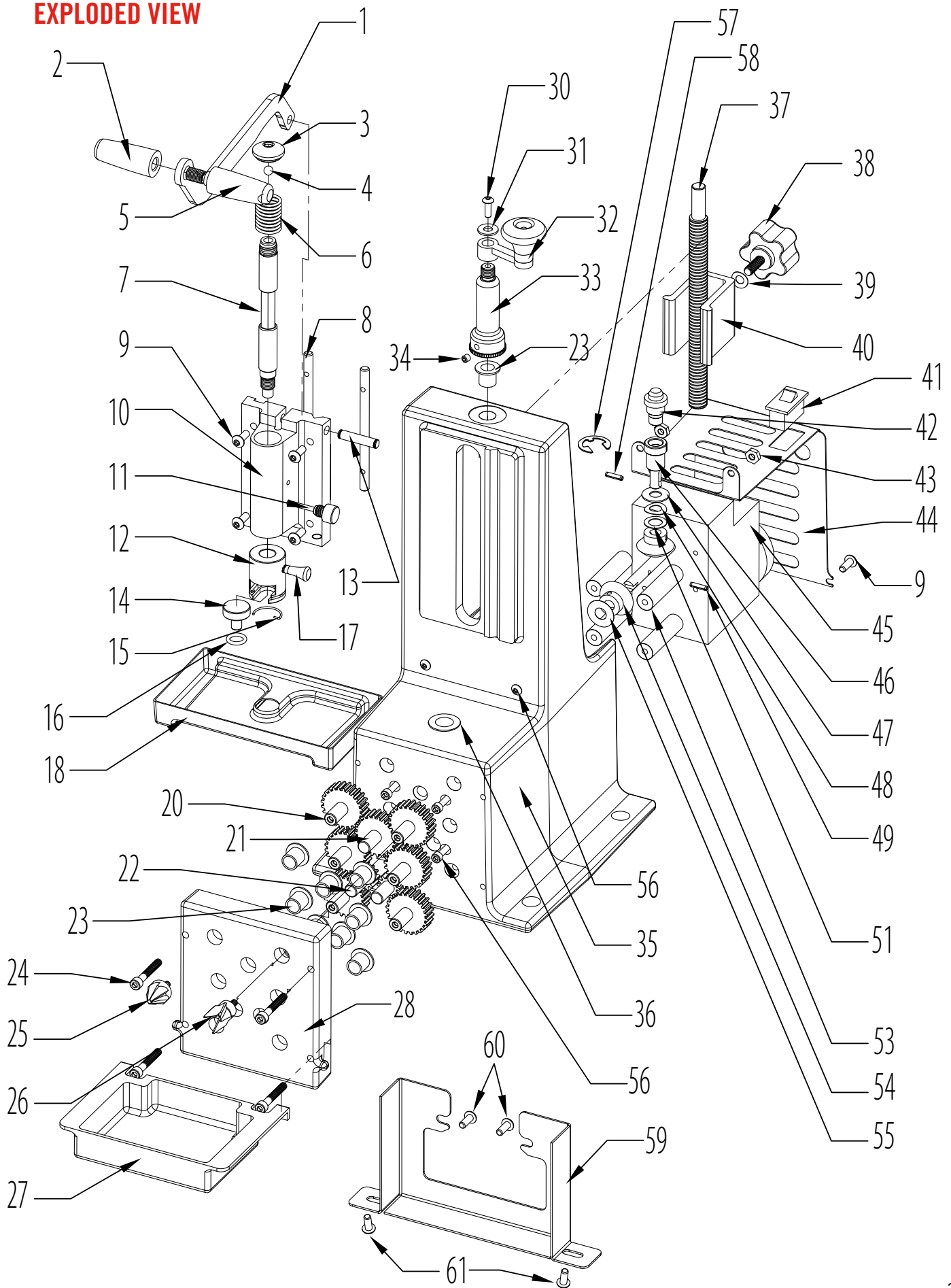

Lock-N-Load® Power Case Prep Center

OVERVIEW

Thank you for purchasing the Hornady® Lock-N-Load® Power Case Prep Center. Please read these instructions before using this machine. If you have any questions about this machine, contact us at 1-800-338-3220.

Product Description:

The Hornady® Lock-N-Load® Power Case Prep Center features a powered Case Trimmer and six work stations for the following reloading tools: Chamfer Tool, Deburring Tool, large and small Primer Pocket Cleaning Heads and caliber specific case neck brushes. The Power Case Prep Center may also be used to deburr flash holes and uniform/ream primer pockets with optional accessories which are sold separately.

The Cam-Lock™ feature on the Hornady® Lock-N-Load® Power Case Prep Center locks the case in a removable Shell Holder for precise trimming. The Lock-N-Load® Power Case Prep Center will only work with Hornady Shell Holders (Hornady Shell Holders are sold separately). The Power Case Prep Center comes with a 5/64" hex wrench and seven interchangeable pilots to accommodate .22 cal, 6mm, .270 cal, 7mm, .30 cal, .38 cal and .45 caliber cartridges. Other pilots are available. Caliber specific pilots are used to align the case mouth on the cutting unit. The Hornady® Lock-N-Load® Power Case Prep Center is engineered to help you significantly improve the efficiency of your reloading process by combining several essential case prep tools into one unit.

General Information About Case Trimming:

Repeated firing and reloading results in the brass of a case flowing towards the case mouth. Reloaded cases grow in length because of these actions. When a case exceeds its maximum case length, it may contact the throat of a firearm. If this happens, the case will not release the bullet properly upon firing and chamber pressure will subsequently increase. Whenever a case grows longer than its maximum specified length it must be trimmed back to a length near the minimum for that caliber. Trim and maximum case length specifications for modern cartridges are published in the **Hornady Handbook of Cartridge Reloading**. (*Refer to this handbook for case trim specifications and other case prep topics.*)

Safety Precautions:

The Hornady® Lock-N-Load® Power Case Prep Center has been engineered with your safety in mind. The likelihood of an injury or property damage is reduced when these safety precautions are followed.

- Become thoroughly familiar with the machine by studying these instructions.
- Leave the machine unplugged until you are ready to prep cases and have read these instructions.
- Do not work on or near damp or wet surfaces.
- Plug power cord into a properly grounded outlet.
- Wear eye protection when operating the Power Case Prep Center.
- Do not use this machine if you're rushed for time and don't take shortcuts by attempting to bypass any of these instructions.

The Hornady® Lock-N-Load® Power Case Prep Center has an in-line fuse to protect the motor from damage when the cutter is under too much load. If you try to trim off more than .050" at a time really fast you may put too much load on the motor which will blow the fuse. The fuse is a 1¼ amp, ¼" x 1¼" fast acting glass fuse. You can purchase these at most automotive or electronic stores. Under normal use, you should never have to replace the fuse. **NEVER USE A FUSE LARGER THAN 1¼ AMP.**

No-Risk Lifetime Warranty

All Hornady reloading tools and accessories are warranted against material defects and workmanship for the life of the product. Simply stated – if it breaks, we'll repair it or replace it at no charge (at Hornady Manufacturing Company's option).

Hornady reloading tools and accessories are warranted against defective materials and workmanship only. This warranty is void if the product (1) has been damaged by accident or unreasonable use, neglect, improper service or other causes not arising out of defects in material or workmanship; or (2) has been altered or repairs have been made or attempted by other than authorized factory personnel; (3) is used commercially; or (4) has been altered or defaced in any way.

This warranty supersedes all other warranties for Hornady products either written or oral. No other warranty is expressed or implied.

Instructions for Power Case Prep Center:

Secure the Hornady® Lock-N-Load® Power Case Prep Center to your reloading bench with four 1/2" diameter bolts, nuts and washers. Select a bolt length based on the dimensions of your reloading bench.

Before you start trimming, make sure all cases have been full-length sized or neck sized with a reloading die.

Check to make sure the power cord is NOT plugged in.

- 1 Insert a caliber specific pilot into the cutter, e.g. use trimmer pilot #1 for .223 Remington. Tighten pilot set screw with the 5/64" hex wrench.

Loosen Main Adjustment Knob on the back of the machine and turn the Main Adjust Handle counter clockwise so there is ample room between the Shell Holder and Trimmer Pilot.

- 2 When you have installed a caliber specific pilot, focus your attention on the Position Screw which is located on the right side of the Spindle Platform. The bottom hole is used to accommodate short/medium cases and the upper hole is used for long cases. To check the initial position of the Shell Holder, insert a case into the Shell Holder Retainer and rotate it counterclockwise to lock up the case. The slot in the Shell Holder should be facing the front of the machine. If it is not, pull down the T-Handle approximately 1/2" and unscrew the Position Screw. Rotate the Spindle Stop clockwise until the slot in the Shell Holder faces the front of the machine. Reinstall the Position Screw in the upper or lower hole.

NOTE: You may have to move the Spindle Stop clockwise or counterclockwise to realign the Position Screw with the upper or lower hole. Snug the Position Screw once it's in position.

To remove the Shell Holder, screw the Shell Holder Retainer clockwise one turn and pull out the Shell Holder.

- 3 Turn the Shell Holder Retainer clockwise one turn, pull out the Plunger or the Shell Holder and the Plunger. Insert the Plunger through the center hole of the Shell Holder. Check to make sure the O-Ring is between the Plunger and the Shell Holder.

Replace the Shell Holder and Plunger and screw the Shell Holder Retainer counterclockwise one turn.

Guide a case specific Shell Holder into the Shell Holder Retainer until it snaps into place, e.g. use Hornady Shell Holder #16 for .223 Remington.

Turn the Cam-Lock™ handle clockwise until the Plunger is flush with base of Shell Holder. Insert a case into the Shell Holder and turn the Cam-Lock™ handle counterclockwise. This will lock the case in the Shell Holder.

NOTE: Check to make sure the slot in the Shell Holder Retainer is facing the front of the machine when you lock a case up in the Shell Holder.

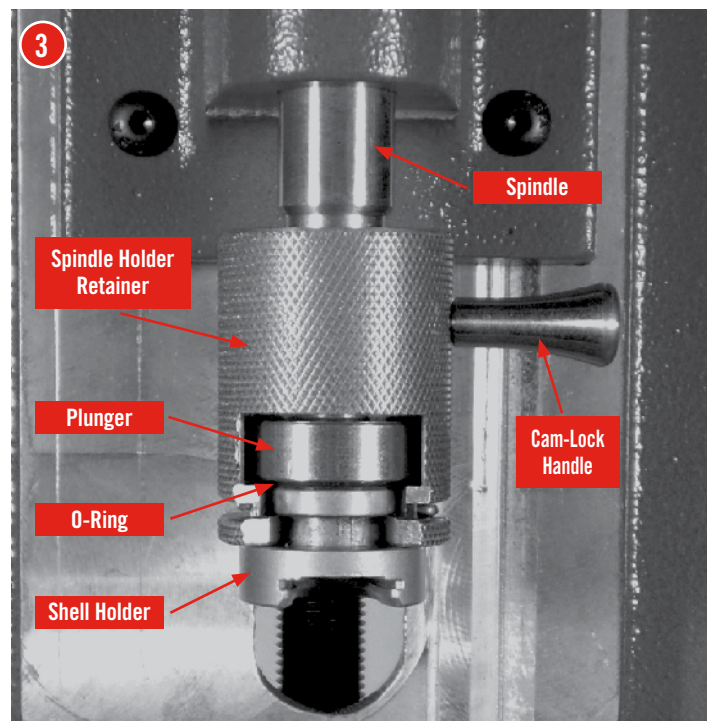
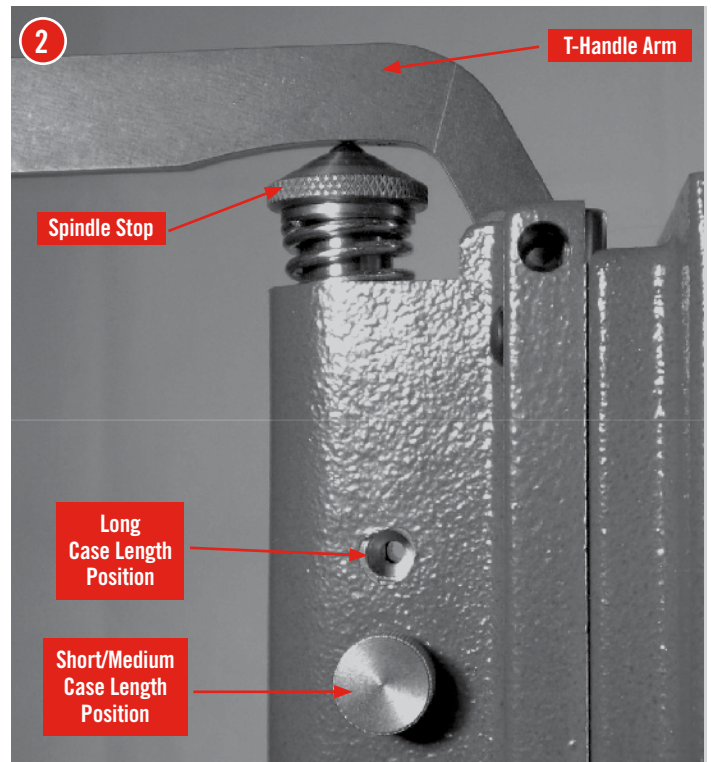
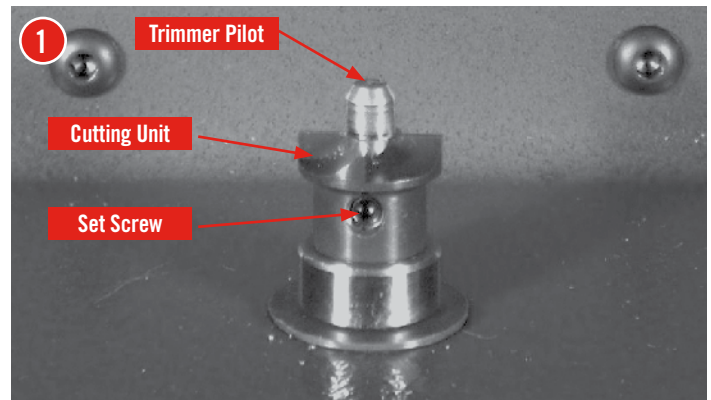

4 Loosen the Main Adjustment Knob (approximately a half turn) and turn the Main Adjust Handle counterclockwise until the case mouth is approximately 0.5" above the trimmer pilot with the T-handle in the up position

5 Tighten the Main Adjustment Knob and lower the T-handle to determine how much fine adjustment is needed until the case mouth makes contact with the trimmer cutter.

Loosen the Main Adjustment Knob (approximately a half turn) and turn the Micro Adjust Handle clockwise or counterclockwise until the case mouth barely touches the trimmer cutter.

NOTE: Each mark (knurl) on the Micro Adjust Handle is equivalent to .001" of vertical adjustment.

Tighten the Main Adjustment Knob, plug in the power cord and press the on switch to start the case trimmer motor.

6 With the case in the Shell Holder, lower T-Handle until it stops on the spindle support and trim case neck.

Raise the T-Handle, shut off the motor and remove the case from the Shell Holder by turning Cam-Lock™ handle in a clockwise direction.

Measure case length and make adjustments by loosening the Main Adjustment Knob and turning the Micro Adjust Handle in a clockwise up or counterclockwise down direction.

Repeat steps 14-16 until desired trim length is obtained. Make sure the Main Adjustment Knob

Instructions for Power Case Prep Tools:

Check to make sure the power cord is NOT plugged in and screw Chamfer Tool, Deburring Tool, small and large Primer Pocket Cleaners, Case Neck Brushes and optional Flash Hole Deburring Tool and/or Primer Pocket Reamer into the threaded sockets. You can arrange the various case prep tools in any manner that suits your wishes.

Plug in the power cord and turn on the motor by pressing the switch on the back of the machine. Sit or stand directly in front of the Hornady Lock-N-Load® Power Case Prep Center so you are not working at an angle.

Use the Primer Pocket Cleaner Heads and the Case Neck Brush to remove accumulated carbon deposits and powder residue from your cases after every reloading cycle. These tools are simple to use but we feel it would be helpful to cover some basic techniques.

7 To use the Primer Pocket Cleaner Head, grasp a fired case and guide the primer pocket to the small or large cleaner head. Use small head for small rifle calibers, e.g. .223 Remington and large head for large rifle calibers, e.g. .243 Winchester. Apply light pressure for approximately five seconds or until carbon deposits are removed from the primer pocket. When you are satisfied with the condition of the

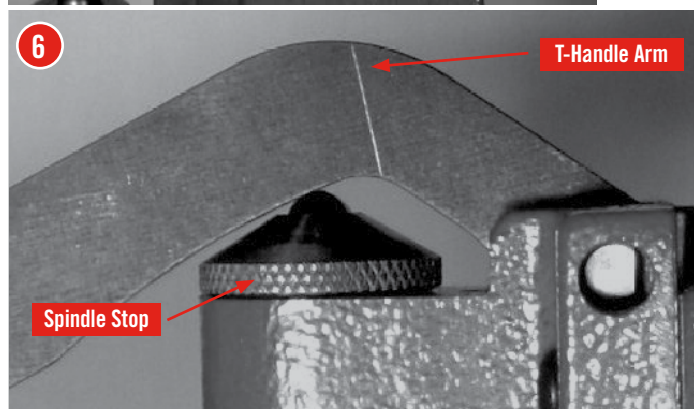
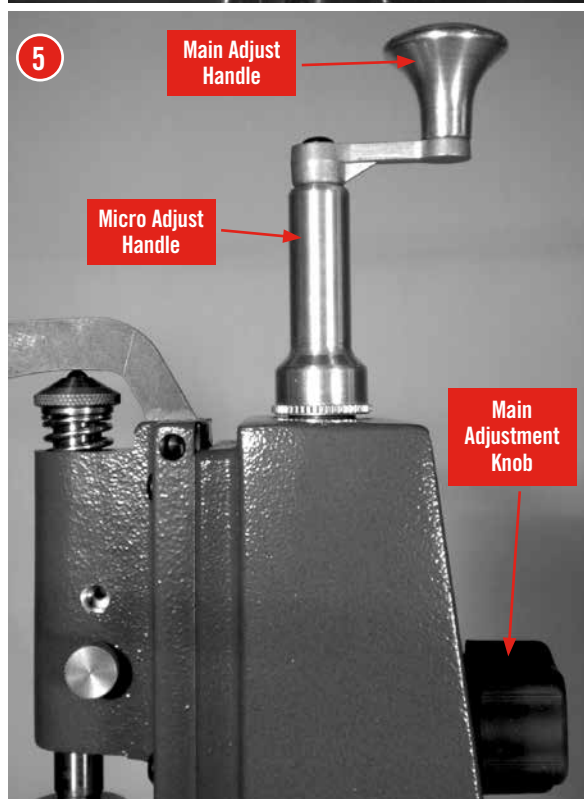
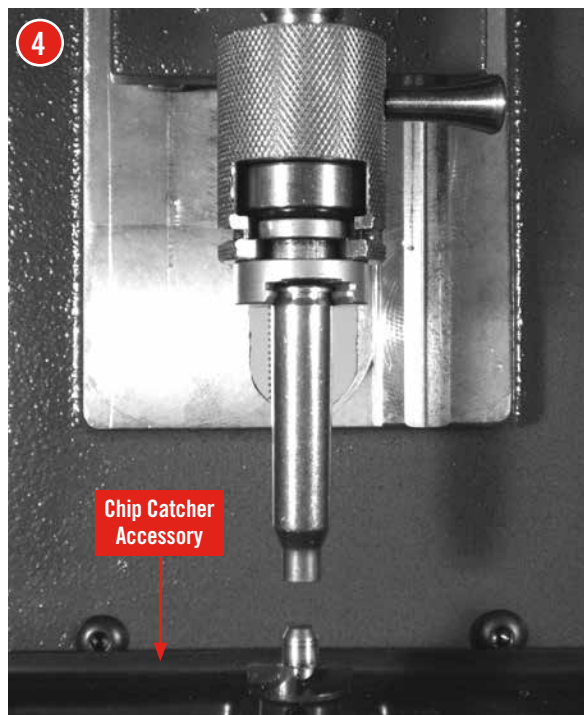

primer pocket use the wire brush to remove powder residue from the case neck. If your cases require trimming then you will need to use the Chamfer and Deburring Tools. These tools are easy to use but we feel it would be helpful to cover the basic techniques.

Grasp a trimmed case and slowly guide the case mouth on to the point of Chamfer Tool with light pressure. Hold the case on the Chamfer Tool for approximately five seconds or until the tool produces a very small bevel on the inner surface of the case mouth. This will make bullet seating easier.

When you are satisfied with the bevel on the case mouth remove the burr from the outer surface of the case neck by guiding the case mouth to the spindle of the Deburring Tool. Apply light pressure and hold case on the Deburring Tool for approximately five seconds or until the burrs are removed from the outer surface of the case neck.

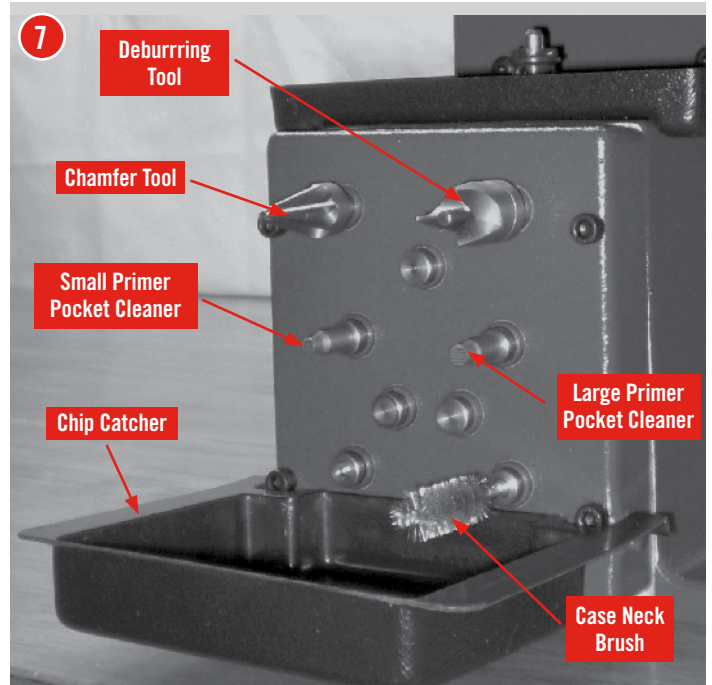

Optional Accessories

The following tools work with the Lock-N-Load® Case Prep Center and are available to purchase separately.

Small Primer Pocket Reamer	390750
Large Primer Pocket Reamer.....	390751
Large Caliber Chamfer (45 Cal. and larger)	050170
Large Caliber Deburr (45 Cal. and larger)	050171
17 Cal. Case Neck Brush.....	380062



P.O. Box 1848, Grand Island, Nebraska 68802-1848
308-382-1390 • 800-338-3220 • Fax: 308-382-5761
www.hornady.com • Hornady.com/contact_us