

Rifle Caliber	Maximum Case Length	Trim-to Length
.356 Winchester	2.015"	2.005"
.358 Winchester	2.015"	2.005"
.350 Remington Magnum	2.170"	2.160"
.358 Norma Magnum	2.515"	2.505"
.375 Winchester	2.020"	2.010"
.375 H & H Magnum	2.850"	2.840"
.378 Weatherby Magnum	2.913"	2.903"
.38/55 Winchester	2.128"	2.118"
.38/40 Winchester	1.305"	1.300"
.401 Winchester	1.500"	1.495"
.44/40 Winchester	1.305"	1.300"
.44 Remington Magnum	1.285"	1.280"
.444 Marlin	2.225"	2.220"
.45/70 Government	2.105"	2.100"
.458 Winchester Magnum	2.500"	2.495"
.480 Weatherby Magnum	2.913"	2.903"

Pistol Calibers	Maximum Case Length	Trim-to Length
.22 Remington Jet	1.288"	1.283"
.221 Remington Fireball	1.400"	1.395"
.25 A.C.P.	.615"	.610"
.30 Luger	.850"	.845"
.30 Mauser	.990"	.985"
.32 A.C.P.	.680"	.672"
.32 Smith & Wesson	.605"	.600"
.32 Smith & Wesson Long	.920"	.915"
.32 H & R Mag.	1.075"	1.070"
9 M/M Luger	.754"	.751"
.357 Magnum	1.290"	1.285"
.380 Auto	.680"	.677"
.38 Super Auto	.900"	.895"
.38 Special	1.155"	1.149"
.38 Smith & Wesson	.775"	.765"
.38/40 Winchester	1.305"	1.300"
.41 Magnum	1.290"	1.285"
.44 Special	1.160"	1.152"
.44 Remington Magnum	1.285"	1.280"
.44/40 Winchester	1.305"	1.300"
.45 A.C.P.	.898"	.895"
.45 Auto Rim	.898"	.894"
.45 Winchester Mag.	1.198"	1.193"
.45 Colt	1.285"	1.280"

## Free Lyman Catalog!

Request your free copy of our current annual catalog.

Visit us on the web at:  
[www.lymanproducts.com](http://www.lymanproducts.com)

# Lyman®

Lyman Products Corporation  
 475 Smith Street  
 Middletown, CT 06457

# Lyman® STAINLESS STEEL DIAL CALIPER

Item #7832212

**Reads to .001"**

- Big 6" Capacity
- Suitable for Machinists and Toolmakers
- Rugged Stainless Steel Body and Jaws
- 4-Way Measurement: Inside, Outside, Depth and Step

## Case Length Trim Guide

## How to read Lyman's Dial Caliper:

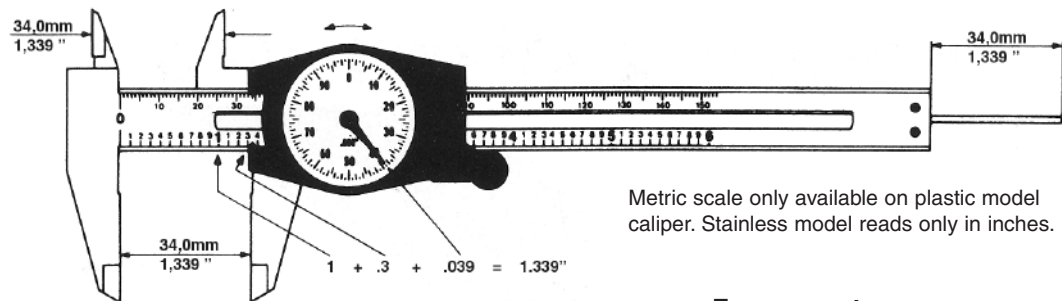

### Four ways to use Lyman's Dial Caliper:

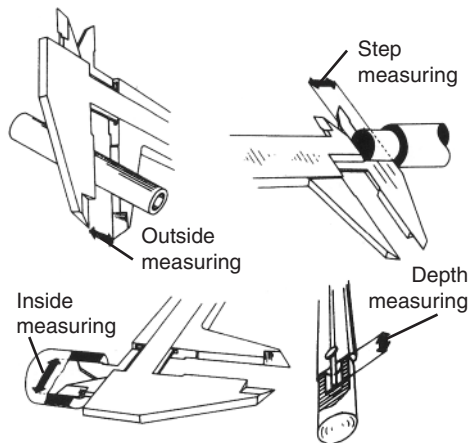

## Zeroing Your Caliper

To insure accuracy before using your new caliper remove protective coating from the inside of the jaws using a clean soft cloth.

"Zeroing" the caliper for measurement of outside diameter or length is easy - close the jaws and turn the dial bezel until the zero lies directly under the dial indicator hand.

Precise measurement of inside, step and depth dimension projects usually requires "zeroing" your caliper for the type measurement desired by registering the caliper against a known dimensional standard and turning the dial bezel until that known dimension lies under the dial indicator hand.

Rifle Caliber	Maximum Case Length	Trim-to Length	Rifle Caliber	Maximum Case Length	Trim-to Length
.17 Remington	1.796"	1.786"	7 x 61 M/M Sharpe & Hart	2.402"	2.392"
.22 Hornet	1.403"	1.393"	7 M/M Remington Magnum	2.500"	2.490"
.218 Bee	1.345"	1.335"	7 M/M Weatherby Magnum	2.550"	2.540"
.222 Remington	1.700"	1.690"	7-30 Waters	2.040"	2.030"
.223 Remington	1.760"	1.750"	7.35 Italian	2.01"	2.00"
.222 Remington Magnum	1.850"	1.840"	.30 MI Carbine	1.290"	1.286"
.225 Winchester	1.930"	1.920"	.30 Remington	2.050"	2.040"
.224 Weatherby Magnum	1.925"	1.915"	.303 Savage	2.015"	2.010"
.22/250	1.912"	1.902"	.30/30 Winchester	2.039"	2.029"
.220 Swift	2.205"	2.195"	.300 Savage	1.871"	1.865"
.22 Savage Hi-Power	2.050"	2.040"	.307 Winchester	2.015"	2.005"
.243 Winchester	2.045"	2.035"	.308 Winchester	2.015"	2.005"
6 M/M Remington	2.233"	2.223"	.30/40 Krag	2.314"	2.304"
.244 Remington	2.233"	2.223"	.30/06	2.494"	2.484"
.25-06 Remington	2.494"	2.484"	.300 H & H Magnum	2.850"	2.840"
25/20 Winchester	1.330"	1.320"	.300 Winchester Magnum	2.620"	2.610"
.256 Winchester	1.281"	1.275"	.308 Norma Magnum	2.560"	2.550"
250/3000 Savage	1.912"	1.902"	.300 Weatherby Magnum	2.825"	2.815"
.257 Roberts	2.233"	2.223"	7.62 Russian Nagant	2.114"	2.105"
.257 Weatherby Magnum	2.550"	2.540"	7.62 x 39 M/M Russian	1.535"	1.525"
6.5 Japanese	1.988"	1.978"	7.65 Argentine Mauser	2.105"	2.100"
6.5 Italian	2.065"	2.055"	.303 British	2.222"	2.212"
6.5 Mann.-Schoe.	2.110"	2.100"	7.7 Japanese	2.270"	2.260"
6.5 Swedish	2.160"	2.150"	.32/20 Winchester	1.315"	1.305"
6.5 x 55 Danish Krag	2.165"	2.155"	.32/40 Winchester	2.130"	2.120"
6.5 Remington Magnum	2.170"	2.160"	.32 Remington	2.050"	2.045"
.264 Remington Magnum	2.500"	2.490"	.32 Winchester Special	2.040"	2.035"
.270 Winchester	2.540"	2.530"	8 M/M Mauser	2.240"	2.235"
.270 Weatherby Magnum	2.550"	2.540"	8 M/M Remington Magnum	2.850"	2.840"
7 M/M Mauser	2.235"	2.225"	.338 Winchester Magnum	2.500"	2.490"
.284 Winchester	2.170"	2.160"	.340 Weatherby Magnum	2.825"	2.815"
7 M/M Rem Exp (.280 Rem.)	2.540"	2.530"	.348 Winchester	2.255"	2.245"
7 M/M-08 Remington	2.035"	2.025"	.351 Winchester	1.380"	1.376"
			.35 Remington	1.920"	1.910"