

Wheeler®
Engineering



DELTA SERIES

AR-15 Armorer's Professional Kit

Product #I56555

Instruction #I025770

Revision: C



STOP!

If you have a problem with this product, **DON'T RETURN IT TO THE STORE WHERE YOU PURCHASED IT.** Contact customer service at...

Battenfeld®
Technologies, Inc.

2501 LeMone Industrial Blvd. / Columbia, MO 65201
573-445-9200 / Email: sales@battenfeldtechnologies.com
Or visit our website @ www.BTlbrands.com

NOT WARRANTED AGAINST MISUSE, ABUSE, OR COMMERCIAL USE.

Limited Warranty

Every Wheeler product is warranted to be free of defects in materials and workmanship for a period of one (1) year from the date of original purchase. Wheeler will, at its option, repair or replace without charge, except for transportation costs, parts that fail under normal use and service when operated and maintained in accordance with our Instructions. This warranty does not apply to normal wear or to items whose life is dependent upon their use and care. This warranty is in lieu of all other warranties, expressed or implied and releases Wheeler, its affiliates, and its vendors from all other obligations and liabilities.

INDEX

- 3..... AR-15 Adjustable Receiver Link
- 3..... Pivot Pin and Roll Pin Installation Tool
- 4..... AR Armorers Vise Instructions
- 7..... Upper Vise Block Clamp with Gas Tube Alignment Tool
- 11... AR-15 Combo Tool with Torque Wrench
- 10... Delta Ring Tool
- 12... AR Front Sight Tool
- 12... Strap Wrench
- 13... AR-15 Bore Guide

- 14... Bore Brush, .22 Cal
- 14... Bolt Carrier Brush
- 14... Chamber Brush
- 14... Magazine/Upper Receiver Brush
- 15... Double-ended General Cleaning Brush
- 15... Cleaning Pick Set
- 15... Maintenance Mat With Exploded View AR-15



- A. AR Armorers Vise
- B. AR15 Combo Tool
- C. Torque Wrench
- D. Upper Vise Block Clamp with Gas Tube Alignment Tool
- E. Maintenance Mat with Exploded View AR-15
- F. Pivot Pin and Roll Pin Installation Tool
- G. AR Front Sight Tool
- H. Delta Ring Tool
- I. Strap Wrench
- J. AR-15 Bore Guide

- K. AR -15 Adjustable Receiver Link
- L. Bore Brush, .22 Cal
- M. Bolt Carrier Brush
- N. Chamber Brush
- O. Magazine/Upper Receiver Brush
- P. Nylon Brush Handle
- Q. Double-ended General Cleaning Brush
- R. Cleaning Pick Set
- S. Custom Fitted Carrying Case

AR-15 Adjustable Receiver Link

The Adjustable Receiver Link is designed to maintain and secure the open position of your AR Upper and Lower assembly during cleaning and maintenance.

Installation:

1. Determine which threaded lower link is needed for your particular application and thread it into the Upper Link. A minimum of three revolutions of thread engagement is recommended.
2. Position your AR lower into a secure holding device. We recommend the Delta Series AR-15 Mag well Vise Block included on the Armorer Vise.
3. Depress the rear take down pin and open the receiver forward.
4. Install the Upper Link engaging the hinge pin boss of your AR Upper Receiver.
5. Make the desired length adjustments to the Lower Link and align it with your lower receiver take down pin and press the pin fully through the lower.

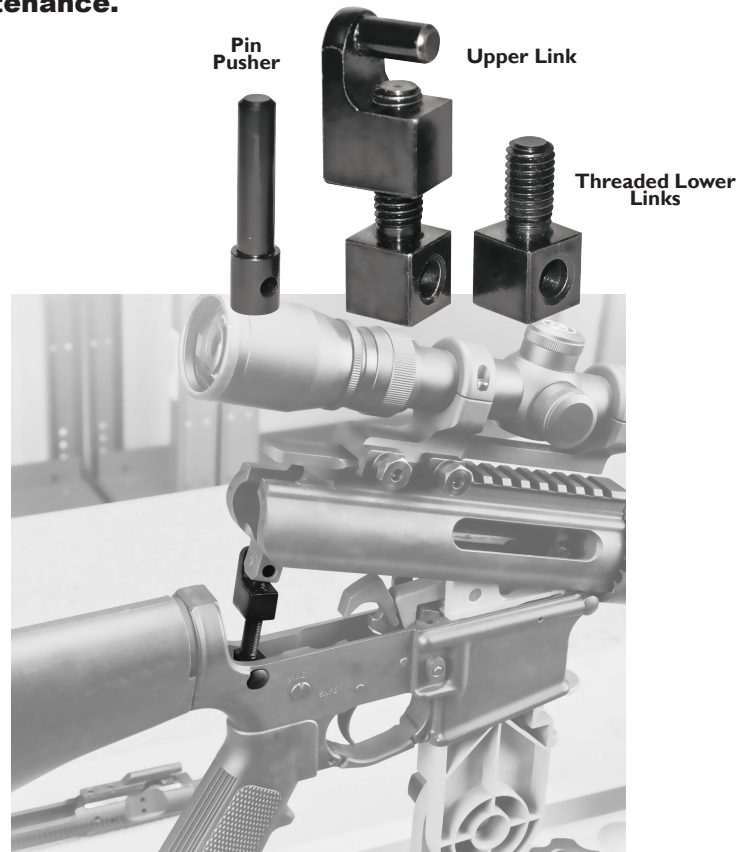

Pivot Pin and Roll Pin Installation Tool

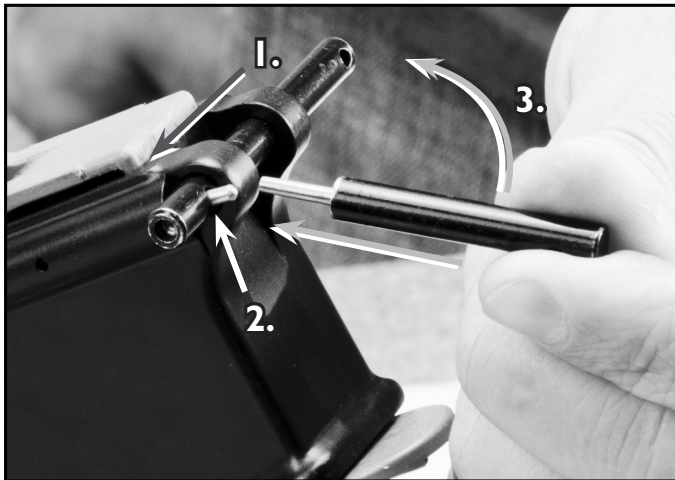

Pivot Pin Instructions:

1. Insert tool into receiver, aligning hole in tool with spring cavity in receiver.
2. Insert Spring and Detent into the cavity through the hole in the tool.
3. Using pin, depress Detent and rotate 90°
4. Carefully slide Pivot Pin into Lower Receiver, pushing tool out simultaneously.

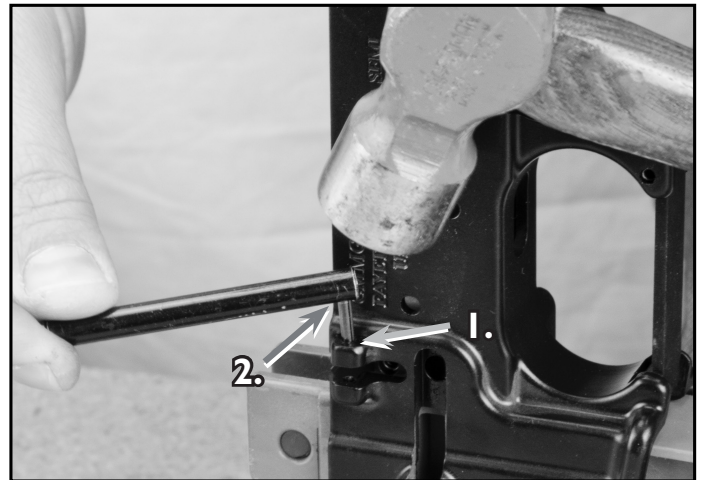

Roll Pin Instructions:

1. Place Roll Pin into hole in Lower Receiver.
2. Place the Blind Hole in the side of the tool onto the roll pin and carefully tap into place.
3. Once started, use the hole on the end of the tool to drive the roll pin into place.
4. Use the narrow tip to finish driving the roll pin flush with the Receiver.

AR-15 AR Armorers Vise Instructions

The AR Armorers Vise was designed to accommodate nearly any position needed to service an AR-15. Each component is capable of multiple positions that enable you to configure an AR for the task at hand.

- The base can be used with the existing rubber feet or be permanently mounted to a bench top surface. (bench top fasteners not included)
- Each “RISER” has two positions that provide an additional 1” placement. 14.25” – 16.25” from center to center.

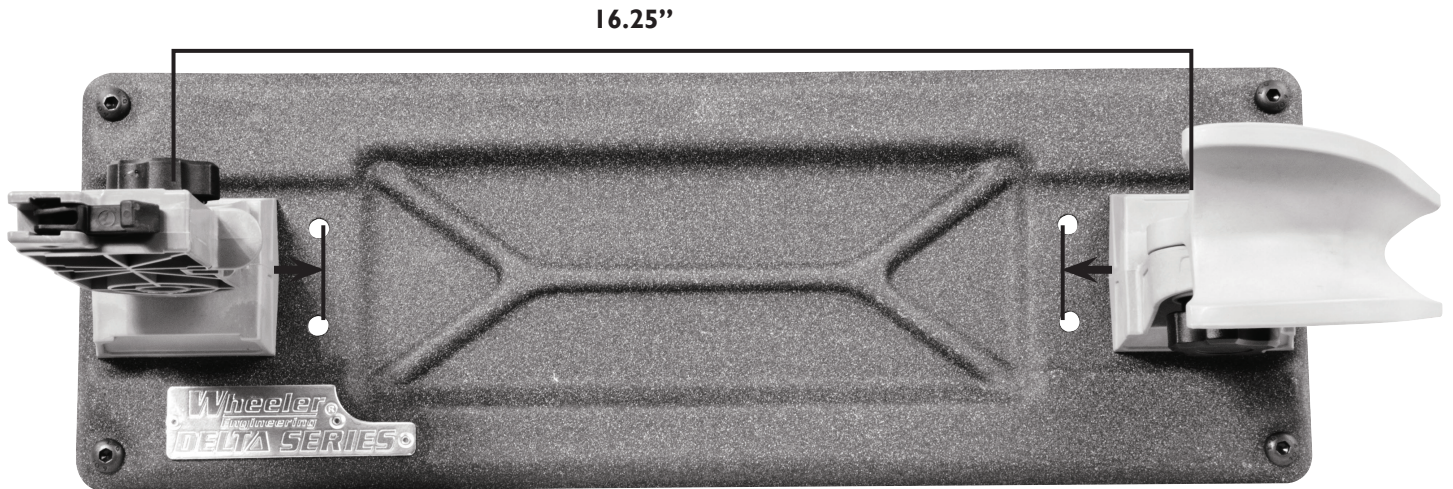
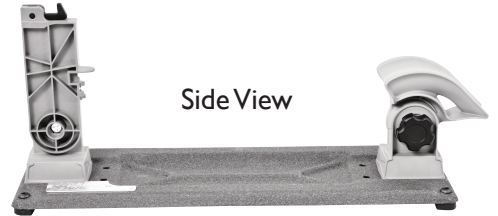

- The rear AR-15 Mag well support is capable of 15° incremental adjustments
 - Integral Hammer Stop
 - Integral Bolt service station

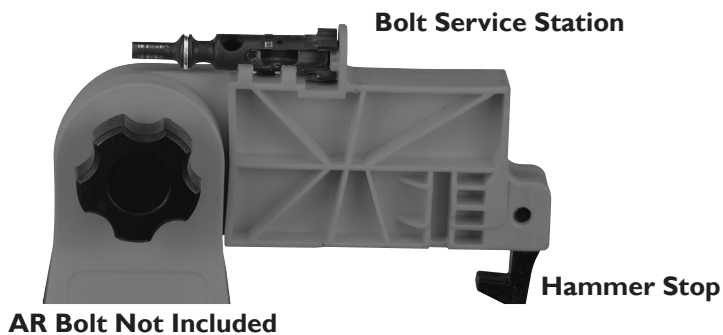
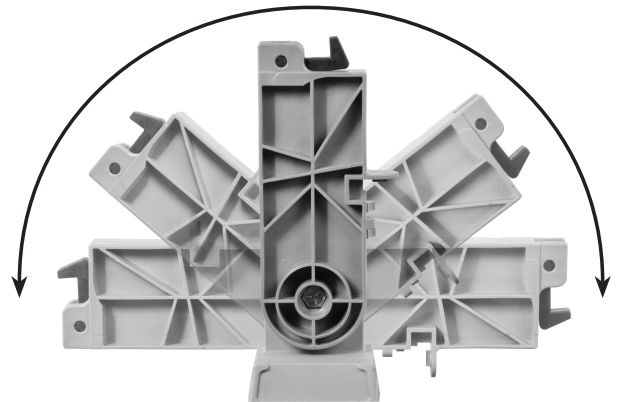

- The Forend Support can rotate in 15° increments and accommodate a range of barrel or forend diameters up to 2.3”

How to use the Bolt Service Station and Hammer Stop

1. Before attempting to remove the ejector, you must first remove the extractor. This can be done by simply pushing the extractor pin through the body of the bolt. (See Photo D)

TIP: use the #550-067 pin punch from the Wheeler Deluxe Screw Driver Kit.

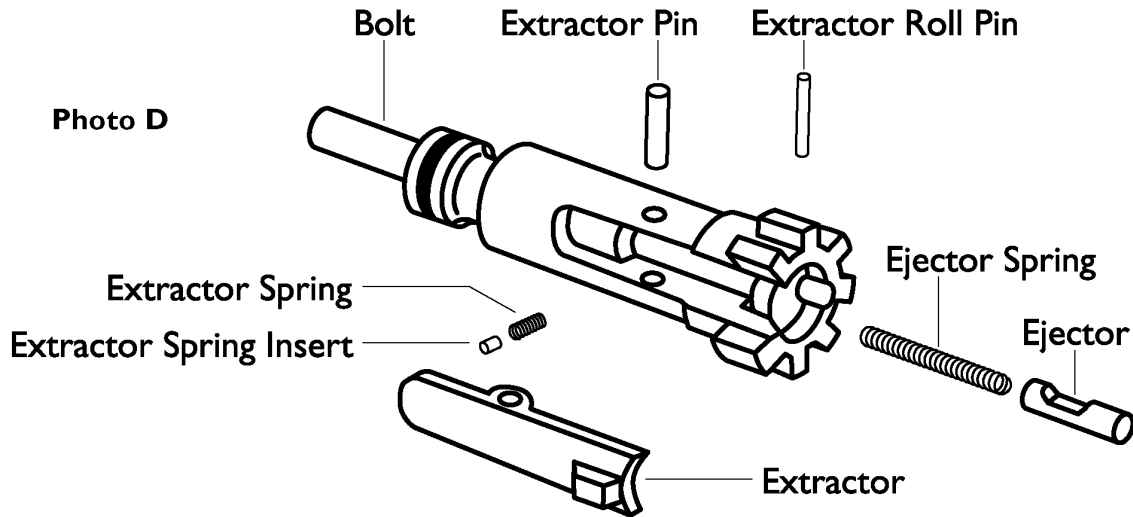

2. Once the Extractor has been removed, insert the bolt in such a fashion that the locking lugs straddle the bolt lug retaining rib located on the side of the Vise Block. (See Photo E)

Bolt Lug
Retaining Rib

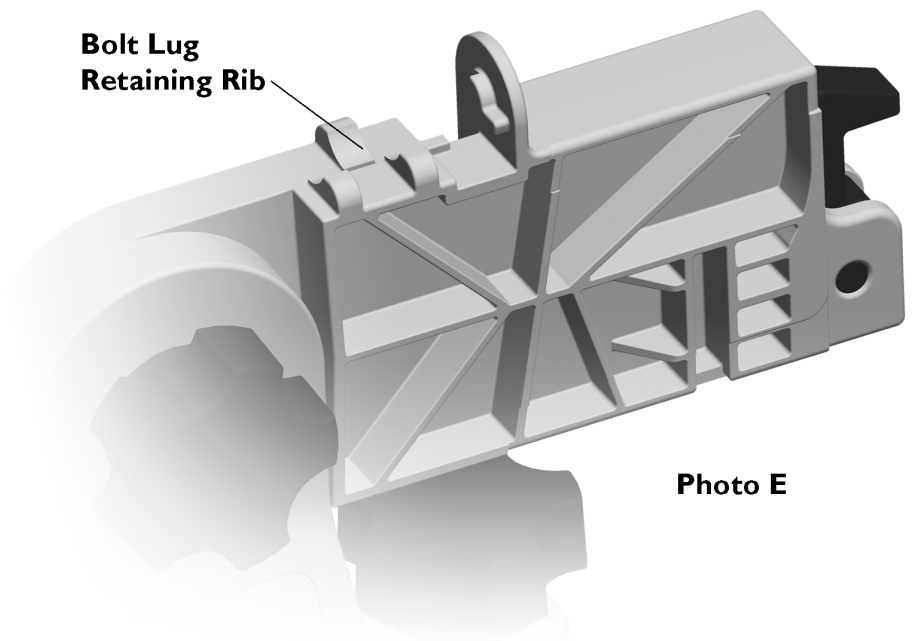

3. Carefully position the bolt as shown in Photo F, rotating slightly clockwise to allow the bolt lugs to pass over the bolt-lug retaining rib as mentioned above.

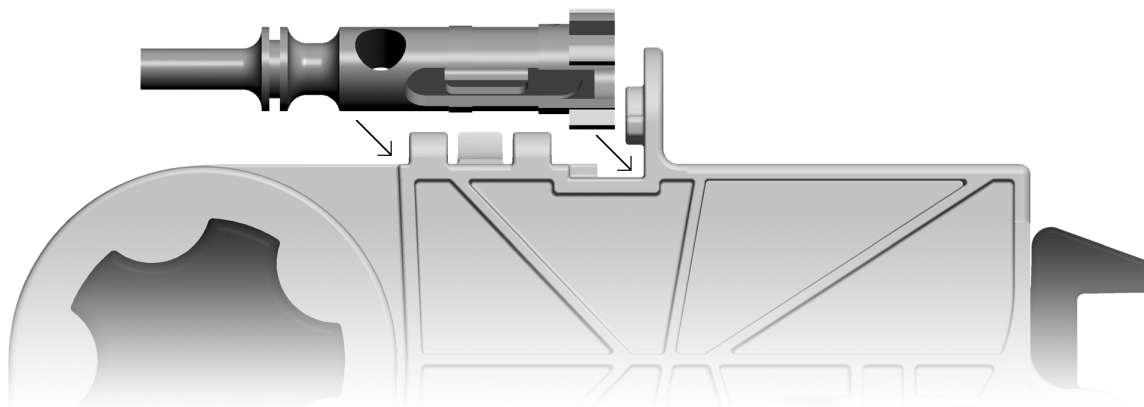

How to use the Bolt Service Station and Hammer Stop

Photo G

4. Once the bolt is in position, push the bolt forward depressing the ejector spring and turn counter-clockwise until the bolt-lugs stop. (See Photos G & H)

5. The bolt is now held hands free to remove the ejector roll pin. TIP: use the # 611-520 pin punch from the Wheeler Deluxe Screw Drive Kit.

Photo H

HAMMER STOP FUNCTION:

The Vise Block includes a Hammer Stop to protect the lower receiver while dry firing.

1. Once the receiver is installed onto the Vise Block, simply rotate the hammer block into position. (See Photo I)

Photo I

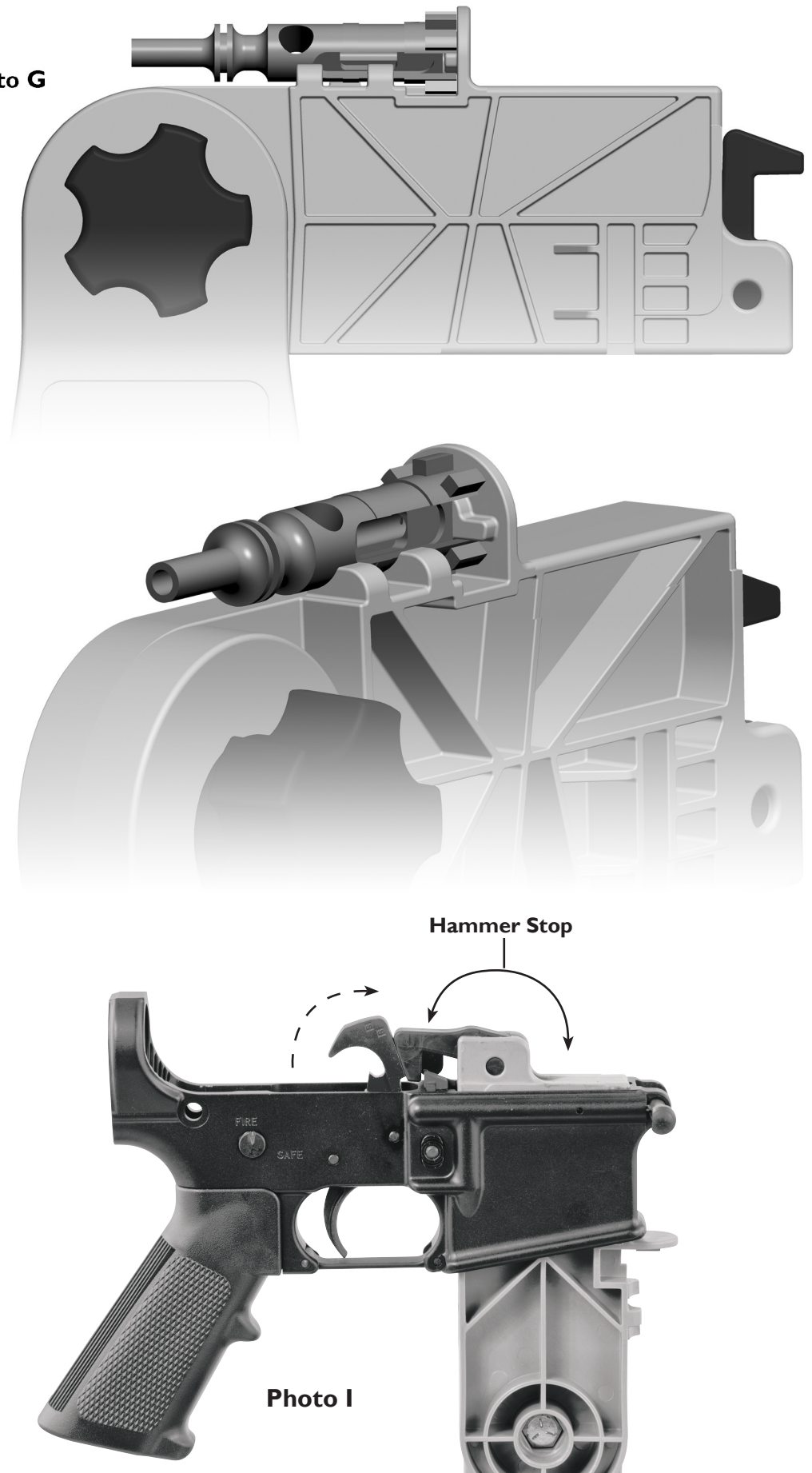

AR-15 Upper Vise Block Instructions

The Delta Series AR-15 Upper Vise Block is optimized for left hand and right hand Mil Spec A2 upper receivers with carry handles, as well as flattop style receivers. Other AR-15 variants may be adapted with special attention to potentially non-conforming surfaces or features. The Block allows you to safely clamp on to your AR-15 upper receiver in a vise holding it securely without twisting, crushing or marring the finish.

Usage Instructions:

1. Place the receiver insert into the rear of the upper receiver; if your receiver is equipped with a dust cover door, the receiver insert is designed to lock in place when the dust door is closed. If your receiver is not equipped with a dust cover, the receiver insert will not be secure until clamping pressure has been applied.

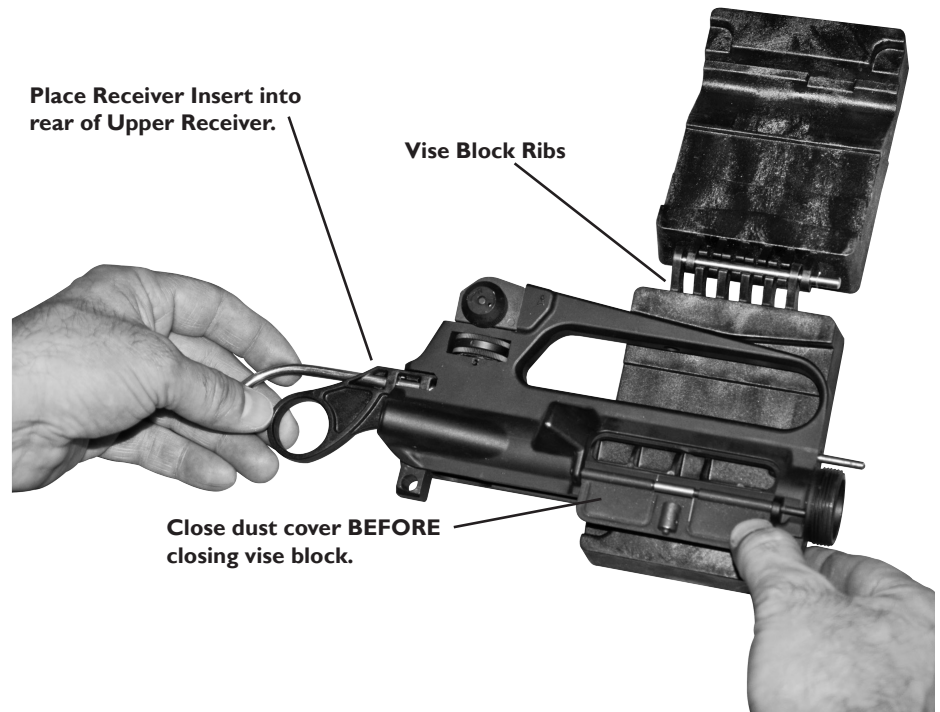

2. Open the UpperVise block on a flat surface with the ribs facing the bench. Position your receiver from either direction and align the front pivot pin lug in the recessed pocket.
3. Close the UpperVise Block and inspect for proper positioning. There should be a gap of approximately 1/16" opposite of the hinge. **A gap in excess of 1/4" may suggest the upper receiver is not Mil Spec and clamping in a vise may damage the Upper Vise Block.** The Wheeler Engineering Delta Series Upper/Pic Rail Vise Block (#156888) will work for these uppers.

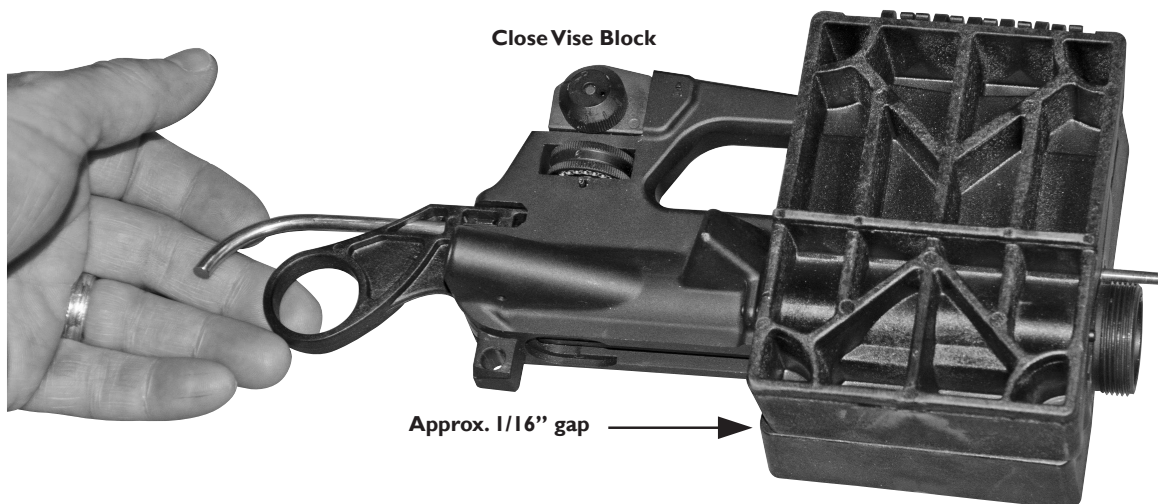

Usage Instructions:

4. The Upper Vise Block is designed to rest on top of the vise jaws using the two ribs along the outside surfaces.

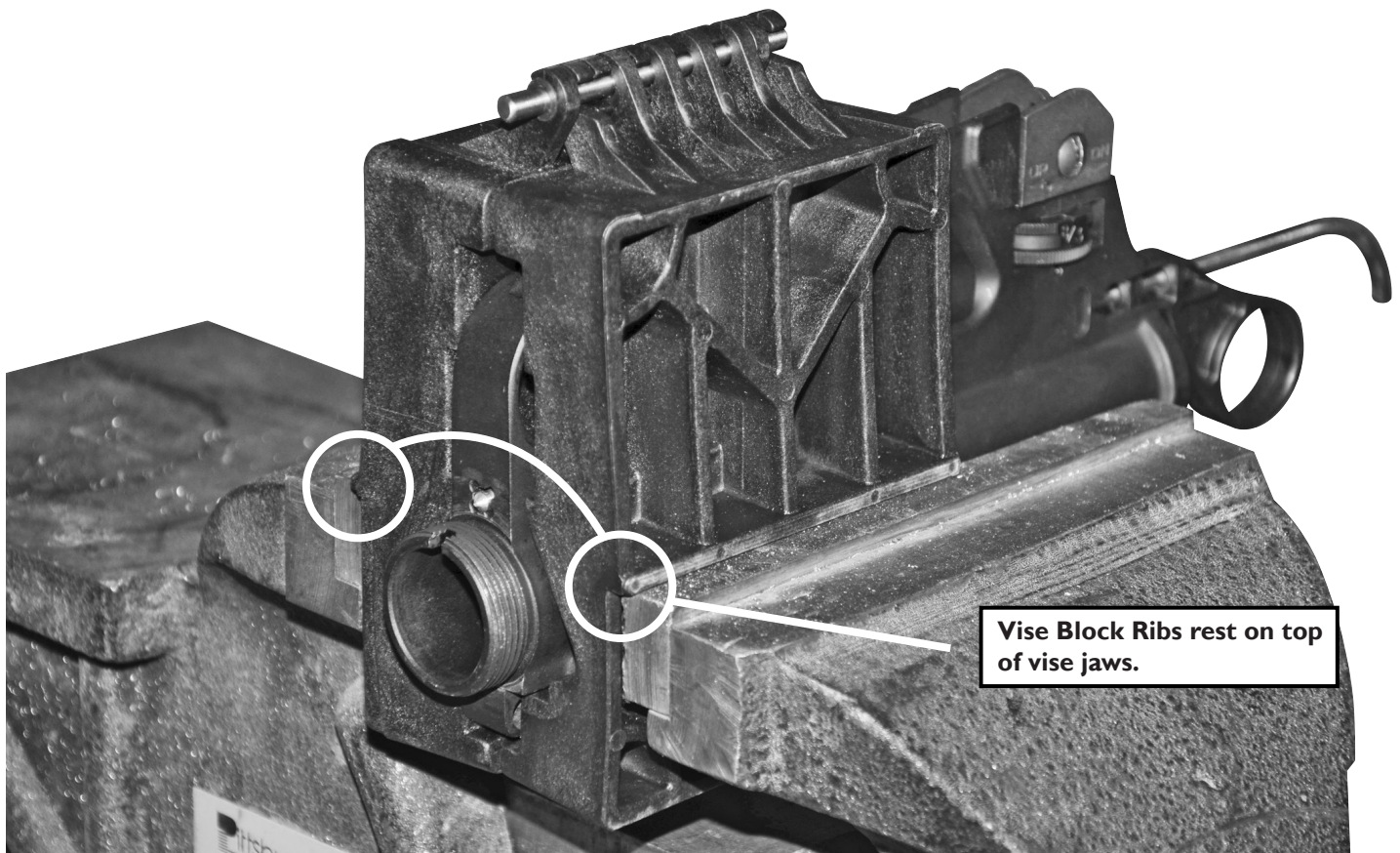

5. Once the Upper Vise Block has been securely clamped into a bench top vise, your upper receiver is ready for all your maintenance needs.
-

Installing a Barrel:

1. *After Steps 1-5 of the Usage Instructions have been completed you are ready to install a barrel on your receiver.*

NOTE: Inspect and clean the threads of both the receiver and the barrel nut prior to assembly. Apply a quality anti-seize compound to the receiver threads. This will enable proper torque to be achieved as well as help prevent thread seizing.

2. Pay careful attention to the position of the Upper Vise Block while assembling the barrel. It may be necessary to apply additional clamping force to maintain position.

Installing a Barrel:

3. Thread the barrel nut on the receiver while holding the barrel in place.

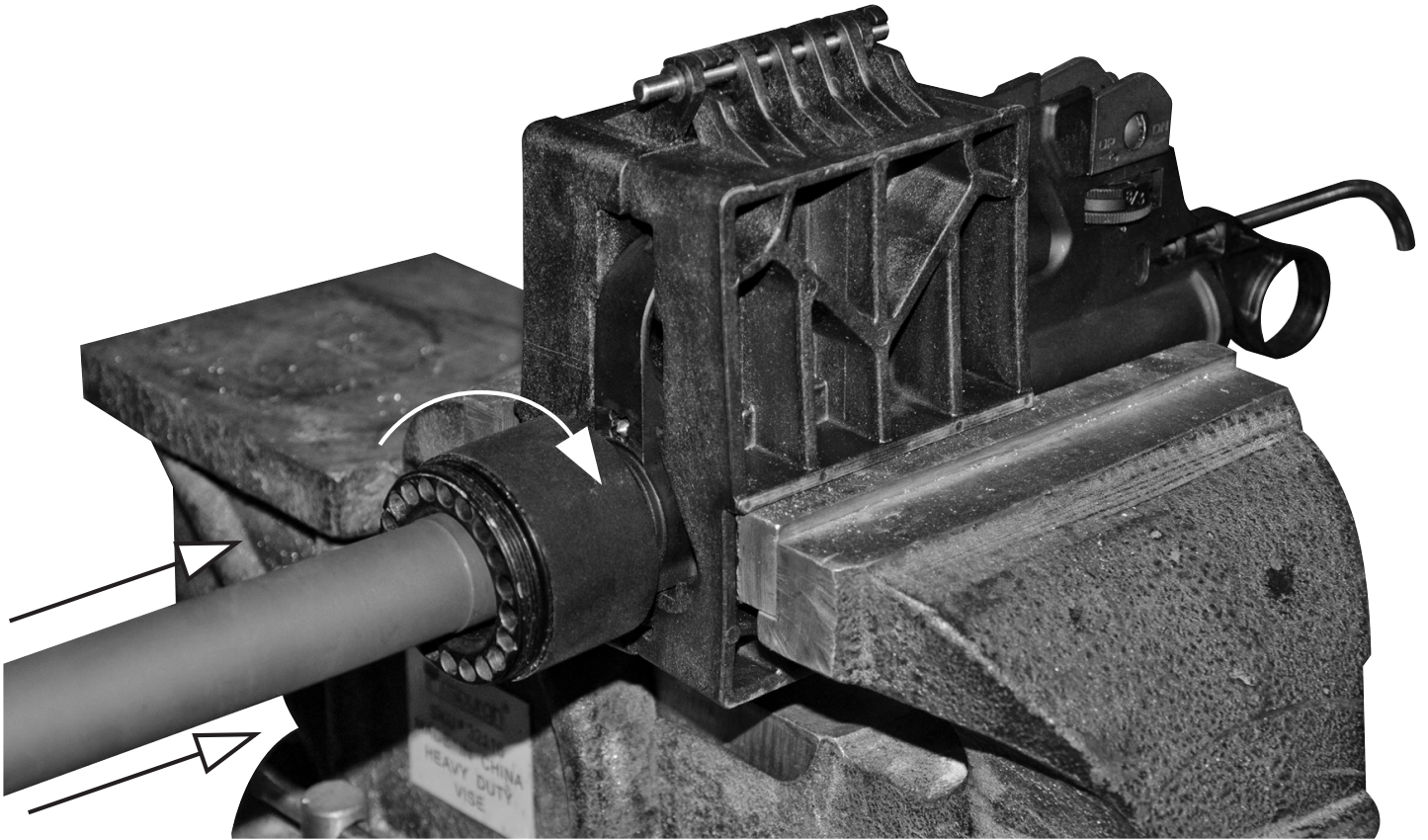

4. Use AR-15 Combo Tool with Torque Wrench by placing hardened steel barrel nut pins onto barrel nut. Place Torque Wrench into 1/2" drive and apply proper barrel nut torque. **(Mil-Spec 30-80 FT-LBS)**



5. Once you have applied the proper barrel nut torque, use the gas tube alignment rod to check for proper barrel nut alignment. Make necessary adjustments until the gas tube alignment rod passes through the receiver and into the barrel nut freely.

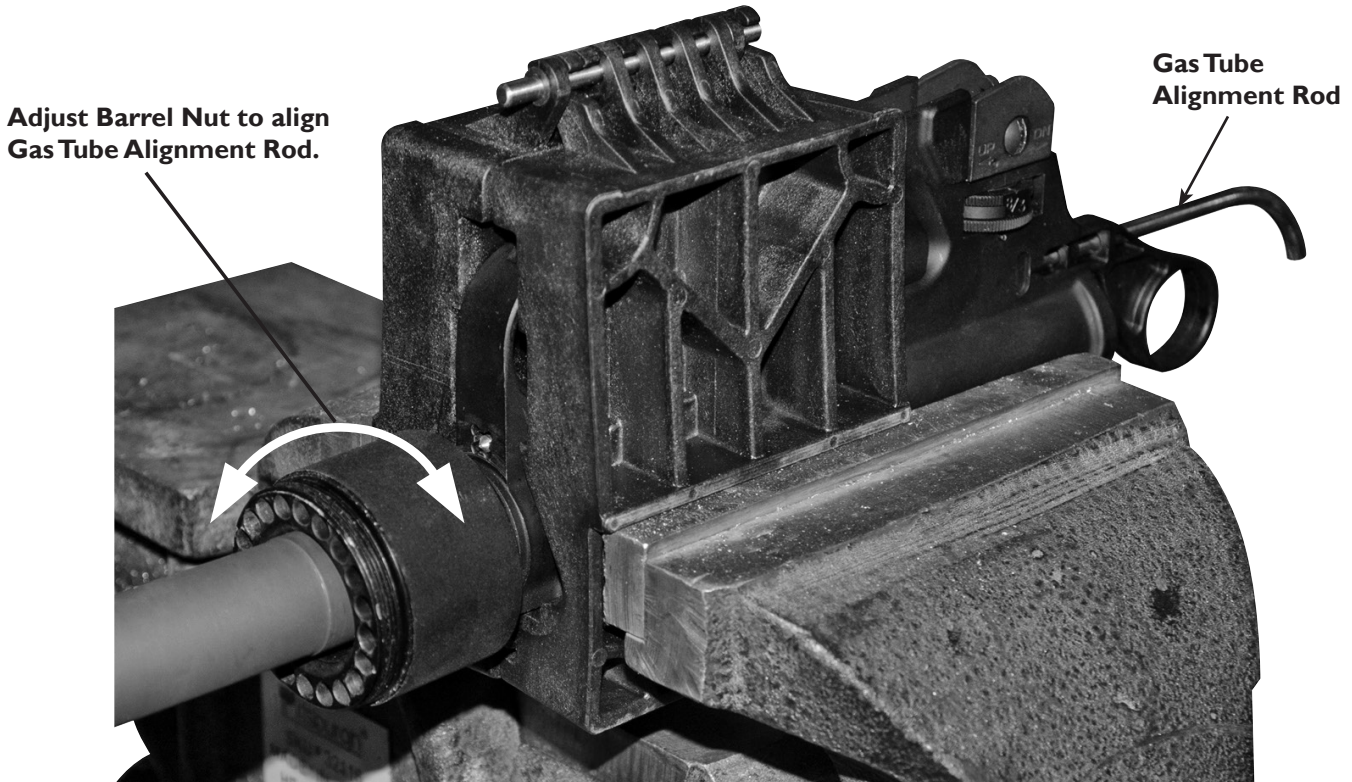

Delta Ring Tool

USAGE INSTRUCTION:

The Delta Ring Tool can be used to remove handguards by inserting the tab on the end of the tool into the magazine well, then squeezing the tool's handles together around the Delta Ring while pushing down. This applies pressure to the Delta Ring, holding it open to allow removal of the handguards. (See photo for reference)

- Makes removing mil-spec AR-15 and M16 handguards easy by compressing the Delta Ring with one hand
- 100% vinyl coating protects the guns finish from damage but is very durable
- Custom formed wire fits securely around Delta Ring for perfect fit
- Welded steel bracket for durability even with stuck or broken Delta Rings

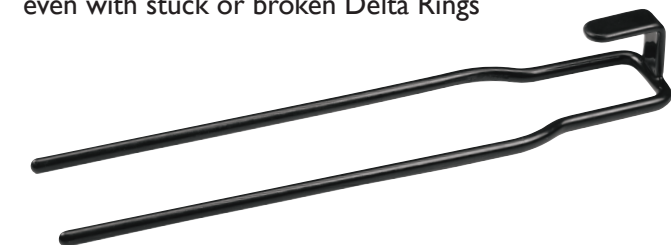

AR-15 Combo Tool with Torque Wrench

Perform most of your AR-15 service needs with a single tool. An innovative layered and laminated stamped steel construction makes the Delta Series AR-15 Combo Tool the most durable AR tool available. This construction method allows the use of hardened steel barrel nut pins designed to hold up to heavy torque requirements. A cut out for a 1/2" drive allows the tool to be used with a torque wrench or ratchet driver. Profiles for buffer tube lock nut and 3/4" flash hider are included. The addition of a bit driver and bit holder with six common bits adds to the versatility.

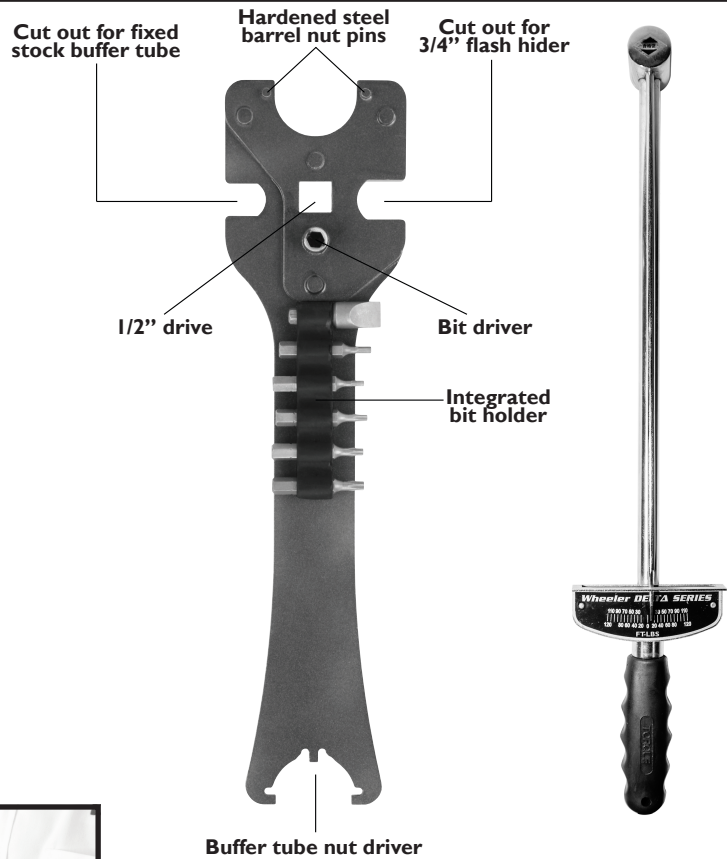

Collapsible stocks can be tricky to assemble. Not with the Wheeler Combo Tool. Its notched end is specifically designed to grab the Receiver Extension Nut and tighten it securely without crushing the nut or buffer tube. The Mag well Vise Block secures your AR for many different assembly and maintenance tasks.

Buffer tube assembly is painless with the Wheeler Combo Tool. The built-in Bit Driver and Bit Driver Set keeps all the bits you need readily available. Included are Torx Drive and Hex bits for mounting scopes, bases, pic rails, and other attachments. The Flat bit works great for buttstocks and pads.



Strap Wrench



This heavy-duty strap wrench gives you plenty of leverage to tighten or remove screw-on free-float handguard tubes. It can loosen tubes that are “frozen” by corrosion between the barrel nut and guard. The large adjustable strap of reinforced rubber wraps securely around any diameter handguard, with no risk of scratching the finish or crushing the tube.

AR Front Sight Tool

- Install and adjust standard Mil-Spec A2 front sights on AR-15, M16 and M4
- Can be used with any 1/4" hex driver
- Key ring for storage serves as a handle
- Black zinc plated steel

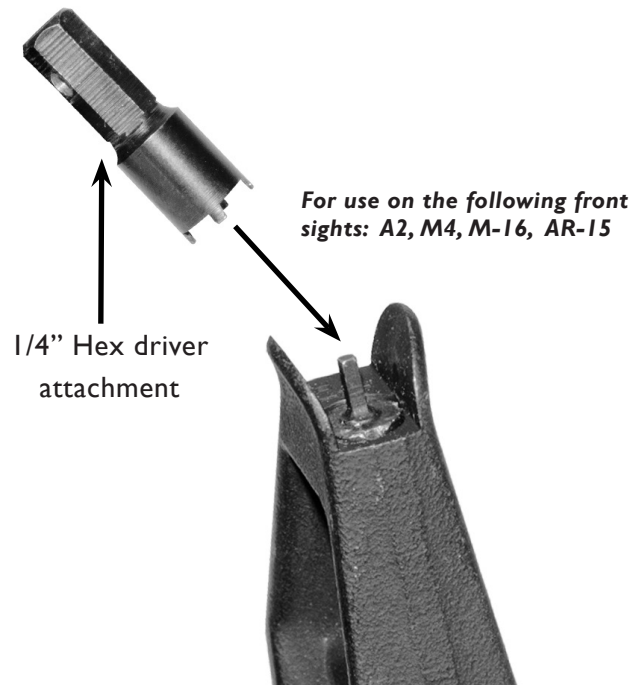

AR-15 Bore Guide

The Delta Series AR-15 Bore Guide will help protect the bore and action of your rifle by properly aligning the cleaning rod and reducing solvent overflow. Cleaning without a bore guide can allow the rod to “bow” and rub or gouge chamber and throat of the bore causing real damage and loss of accuracy. Keeping the rod properly aligned not only protects your barrel, it directs the force exerted on the cleaning rod handle allowing tight patches to be pushed more easily.



INSTRUCTIONS:

1. Remove the bolt carrier assemble and charging handle from the upper and insert the Bore Guide.
2. Rotate the Bore Guide until the solvent port is facing directly upward.
3. Close dust cover to lock the Bore Guide into position.
4. After cleaning, rotate the Bore Guide approximately 90 degrees clockwise until the solvent port is aligned with the dust cover side of the upper and pull the guide to the rear. This will open the dust cover and release the Bore Guide.

2 sets of chemical-resistant O-Rings to accommodate varying sizes of receiver inner diameters & are non-marring to inside of receiver

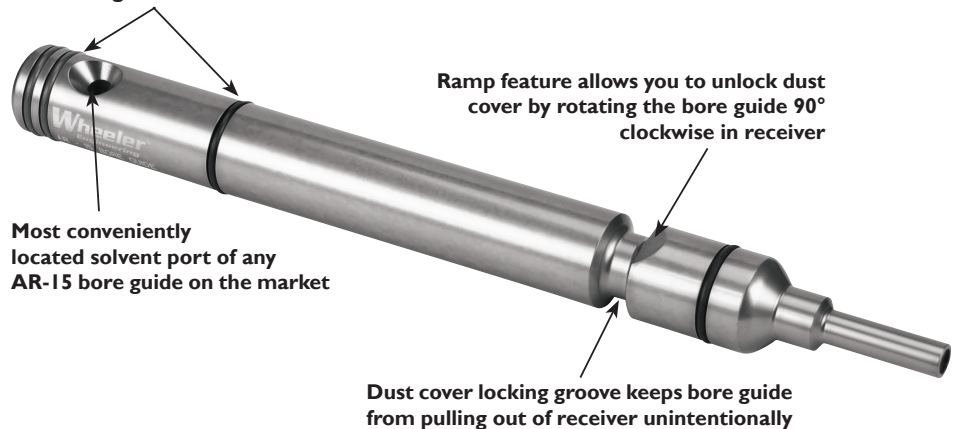

O-RINGS:

The chemical resistant O-rings will retain the Bore Guide in uppers that do not have dust covers. Two sets of O-rings are provided; the black colored set will produce a tighter fit, the green set will produce a looser fit. The two grooves at the very rear of the Bore Guide are the “storage position” for the spare set of O-rings. A very small flat bit screwdriver works well to remove the O-rings.



AR-15 Complete Brush Kit

The Wheeler Delta Series AR-15 Complete Brush Set is specifically designed for cleaning your AR-15. The brushes are made of a high quality stiff nylon, spun around steel cores for added stability. The brushes feature an 8-32 thread that fit on the included cleaning handle or any 8-32 cleaning rod. The brush set has every brush you need to clean your rifle, plus everything you need to keep your magazines clean and running reliably.



Chamber Brush



Upper Receiver Magazine Brush



.22 Caliber Bore Brush

The Brush Set Includes:

- Magazine/Upper Receiver Brush with Magazine Takedown Tool
- Bolt Carrier Brush
- Chamber Brush
- .22 Caliber Bore Brush
- Handle for action and chamber cleaning

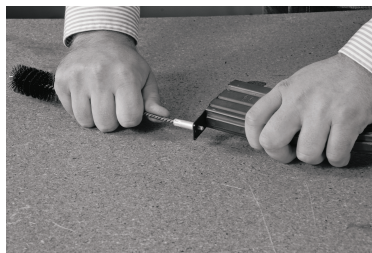

Magazine takedown tool removes butt plates quickly and easily



Bolt Carrier Brush

Double Ended General Cleaning Brush

This Double-ended brush is solvent-proof with a polypropylene handle. It provides a large, contoured series of nylon bristles to cover curves and open areas. It can reach down inside actions or chambers. It also provides superior scrubbing action for individual parts. The nylon bristles won't scratch delicate blued surfaces.

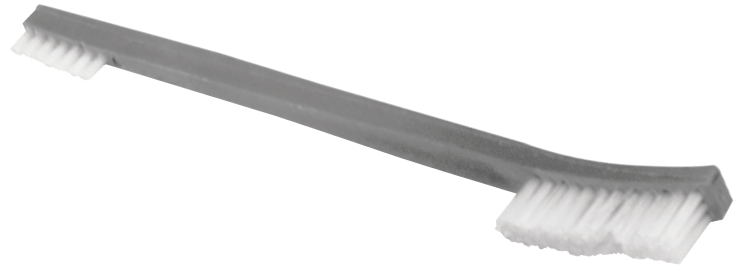

Cleaning Pick Set

These tools allow you to reach into tight spaces to remove powder fouling, caked-on lubricants, and the grit and grime that accumulate with use and time. Made of high-strength polymer, these picks won't harm the finish of your gun and can last for many years. Each one have a different shaped end to give you eight options for getting into those hard to reach areas.

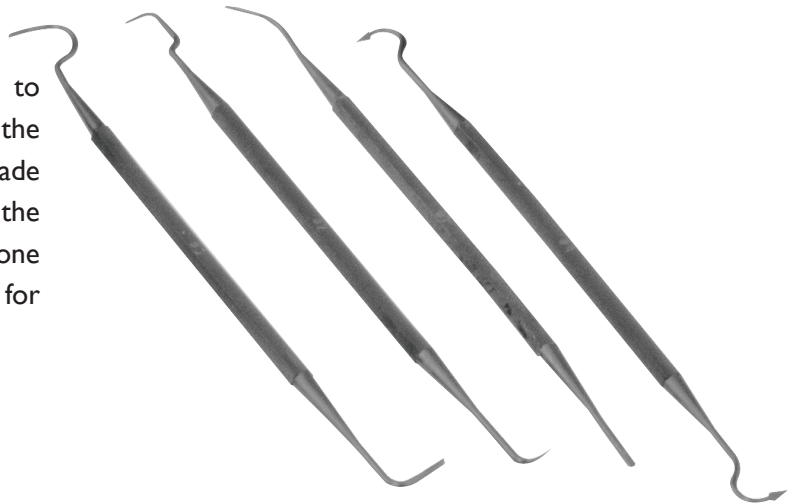

20" x 47" AR-15 Maintenance Mat

- Screen printed exploded view of an AR-15 for easy part identification
- Perfect for cleaning & disassembling firearms
- No-mar, padded neoprene surface protects the firearm's finish
- Absorbs oils & solvents keeping surface dry
- Helps keep track of small gun parts
- Rolls up to easily fit in your range box

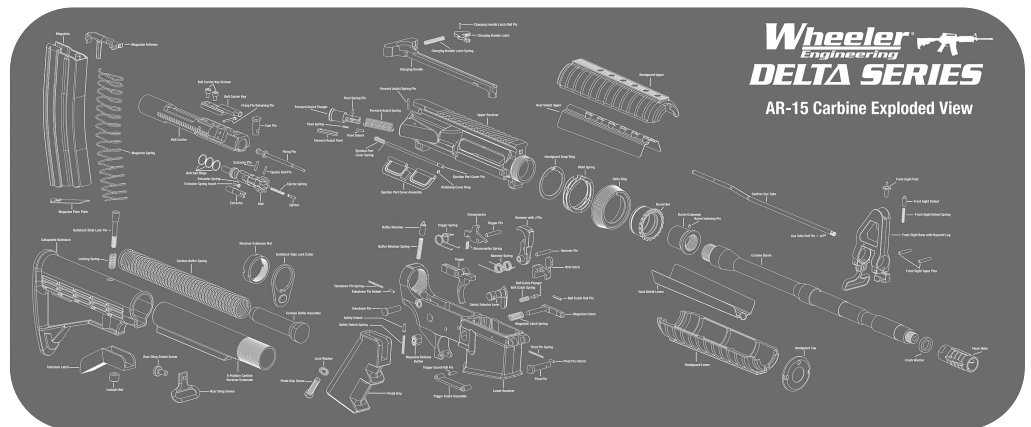

AR-15 Armorer's Professional Kit



Battenfeld[®]
Technologies, Inc.

2501 LeMone Industrial Blvd. / Columbia, MO 65201
573-445-9200 / Email: sales@battenfeldtechnologies.com