

ERVXXSVB1100
 ERVXXSHB1100
 HRVXXSVB1100
 HRVXXSHB1100

Energy Recovery Ventilator Heat Recovery Ventilator

Installation Instructions

TABLE OF CONTENTS

	PAGE
SAFETY CONSIDERATIONS	1
INTRODUCTION	2
INSTALLATION CONSIDERATIONS	2
COMPONENT DESCRIPTION	2
UNIT INSTALLATION	3
WALL CONTROL	4
OPERATING THE ERV/HRV WITH THE INFINITY/EVOLUTION CONTROL	6
ELECTRICAL CONNECTIONS	6
ACCESSORIES	6
BALANCING ERV/HRV	7
VENTILATION EVALUATION	8
CONTROL BOARD OPERATION	8
CARE AND MAINTENANCE	8
TROUBLESHOOTING	9

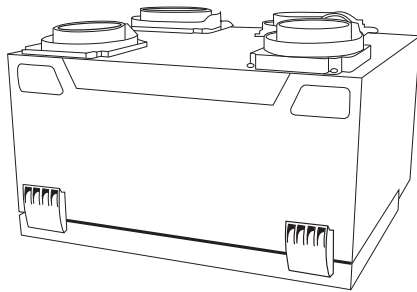

Fig. 1 - ERV/HRV Unit (Top Port)

A05229

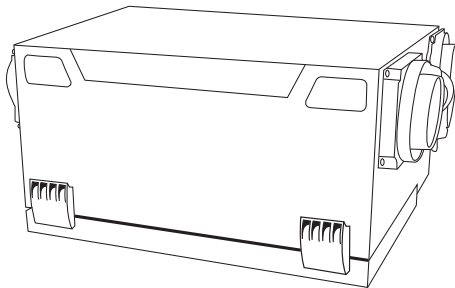

Fig. 2 - ERV/HRV Unit (Side Port)

A05330

NOTE: Read the entire instruction manual before starting the installation.

SAFETY CONSIDERATIONS

Improper installation, adjustment, alteration, service, maintenance, or use can cause explosion, fire, electrical shock, or other conditions which may cause death, personal injury or property damage. Consult a qualified installer, service agency, or your distributor or branch for information or assistance. The qualified installer or agency must use factory-authorized kits or accessories when modifying this product. Refer to the individual instructions packaged with kits or accessories when installing.

Follow all safety codes. Wear safety glasses, protective clothing and work gloves. Have a fire extinguisher available. Read these instructions thoroughly and follow all warnings or cautions included in literature and attached to the unit. Consult local building codes and the current editions of the National Electrical Code (NEC) NFPA 70.

In Canada, refer to the current editions of the Canadian Electrical Code CSA C22.1.

Recognize safety information. This is the safety-alert symbol . When you see this symbol on the unit and in instruction manuals, be alert to the potential for personal injury.

Understand the signal words **DANGER**, **WARNING**, and **CAUTION**. These words are used with the safety-alert symbol. **DANGER** identifies the most serious hazards which **will** result in severe personal injury or death. **WARNING** signifies hazards which **could** result in personal injury or death. **CAUTION** is used to identify unsafe practices which **may** result in minor personal injury or product and property damage. **NOTE** is used to highlight suggestions which will result in enhanced installation, reliability, or operation.

INTRODUCTION

The Energy/Heat Recovery Ventilator (ERV/HRV) is used to exchange indoor stale air with outside fresh air. The unit is equipped with a special energy/heat recovery core which transfers both sensible and/or latent heat between the fresh incoming air and stale exhaust air. The cross-flow design core allows entering and leaving air streams to transfer heat and/or latent energy without mixing. See Fig. 3.

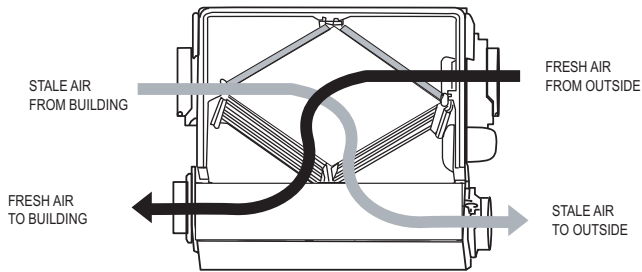

A07460

Fig. 3 - ERV/HRV Airflow During Air Exchange
(Bottom view with access door removed)

The model operates at 2 airflows, 50 CFM in low speed and 100 CFM in high speed. This unit comes in two configurations, vertical or horizontal. Special attention should be given to duct application, balancing the ERV/HRV, and locating unit for easy access and routine maintenance.

INSTALLATION CONSIDERATIONS

Inspect Equipment

Move carton to final installation location. Remove ERV/HRV from carton taking care not to damage unit. Remove all packaging and inspect unit for damage. Remove parts bag from inside unit. File claim with shipping company if shipment is damaged or incomplete. Check to make sure ERV/HRV unit matches Fig. 1 or Fig. 2.

Select Location

The ERV/HRV should be located in a conditioned space and in close proximity to a fused power source. It should be easily accessible for routine maintenance.

If ERV/HRV is installed independent of a forced-air system, unit should be located near the center of the air distribution system. If

ERV/HRV is installed in conjunction with a forced-air system, unit should be located next to (or close to) the indoor equipment.

COMPONENT DESCRIPTION

The following listed items are components of ERVCCSHA. See Fig. 4.

1. Exhaust-air connected to outdoor air exhaust hood.
2. Fresh-air intake connected to outdoor air inlet hood.
3. Fresh-air supply from ERV connected to return-air duct of forced-air system.
4. Mechanical filters trap dust contained in the air.
5. HRV cores are cross-flow. ERV cores are counter-flow. The cores transfer heat and energy between the two air streams.
6. Blowers bring in fresh-air from outside and exhaust stale-air to outside.
7. Electronic control circuit ensures proper unit operation.
8. Stale air return from building connected to return-air duct system.

ERV ports on side (bottom view)

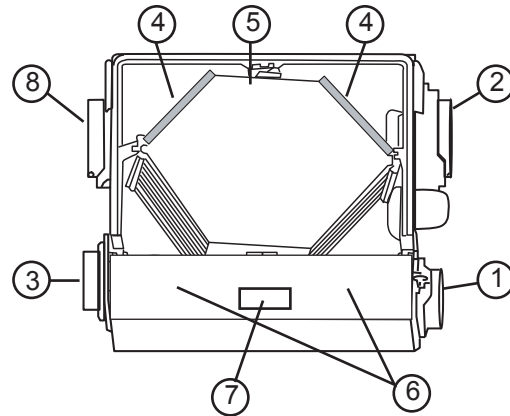

A12550

Fig. 4 - Conventional Horizontal Unit

See Fig. 5 for terminal connector block for wiring wall and timer controls.

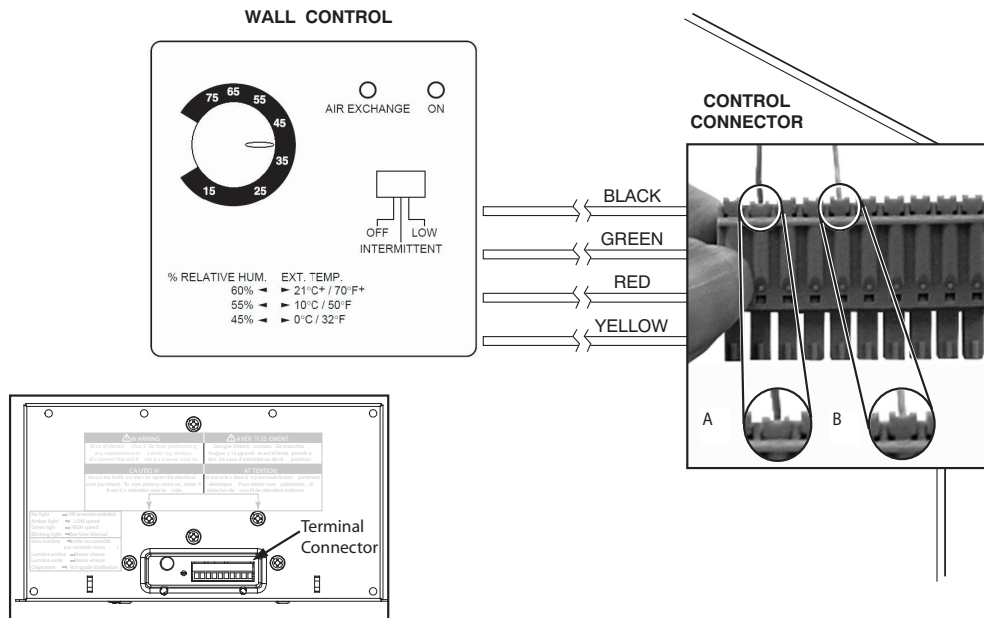

Fig. 5 - Control Connector

A07418

UNIT INSTALLATION

⚠ CAUTION

UNIT DAMAGE HAZARD

Failure to follow this caution may result in equipment damage or improper operation.

Do not install ERV/HRV in a corrosive or contaminated atmosphere.

Mount Unit

The ERV/HRV can be suspended from floor joists using chains and 4 springs. Attach metal hanging bracket to all 4 sides of cabinet. See Fig.6. The unit may be installed on a shelf if an isolation pad is provided to dampen vibration. Unit should always be installed as level as possible.



Fig. 6 - Chain Spring Installation

A05331

Independent System Application

In the absence of a forced-air system and a typical duct system layout, the ERV/HRV can be applied as an independent or stand

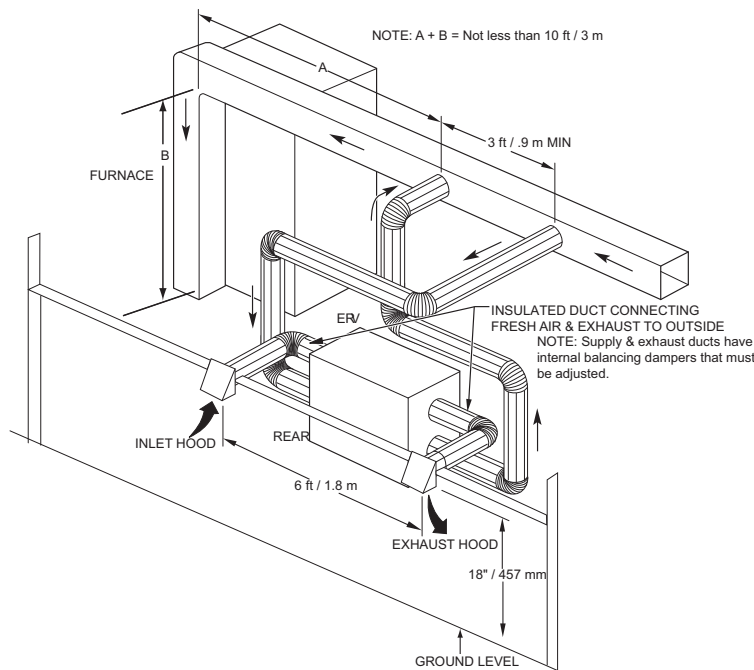

Fig. 7 - Exhaust Ventilation

A07282

alone unit. To ensure comfort, this type of application involves running both fresh-air and return-air registers (or stale-air pickup registers) throughout the home.

Fresh-air registers are normally located in bedrooms, dining room, living room, and basement. It is recommended that registers be placed 6 to 12-in (152 to 305mm) from the ceiling on an interior wall and airflow directed toward ceiling. If registers are floor installed, airflow should be directed toward the wall.

⚠ WARNING

CARBON MONOXIDE POISONING HAZARD

Failure to follow this warning could result in personal injury or death.

Do not install return-air registers (or stale-air pickup registers) in same room as gas furnace or water heater.

Return-air (or stale-air pickup registers) are normally located to draw from kitchen, bathroom, basement, or other rooms where stale-air can exist.

Proper size and type of registers must be used to minimize pressure drop. The velocity of airflow through register should not be above 400 ft (122m) per minute.

Maximum length of duct for the system should be designed according to the highest speed of the unit. Refer to specifications listed in unit Product Data Digest for ventilation capacities.

Forced-Air Application

Most ERV/HRV applications will be installed in conjunction with new or existing forced-air system. To operate properly, the fresh-air supply and stale-air return from ERV/HRV connect directly to return-air duct system. This is how the ERV/HRV distributes fresh air and removes stale air from inside of building. See Fig. 7. For these installations, furnace or fan coil blower must be interlocked and operate continuously whenever ERV/HRV is energized. See Fig. 17 for interlock wiring detail.

NOTE: The fresh air from ERV/HRV is introduced into return-air duct at a point no less than 6 ft (1.8m) upstream of furnace or fan coil. This connection should be direct. See Fig. 7. This is to allow incoming fresh-air to mix before entering indoor equipment.

Connect Ducts to ERV/HRV

⚠ CAUTION

PROPERTY DAMAGE HAZARD

Failure to follow this caution may result in minor property damage from sweating duct or loss of unit efficiency and capacity.

If ERV/HRV duct work is installed in an unconditioned space, insulated flexible duct is required.

Insulated flexible duct is required on both fresh-air inlet and exhaust-air outlet ducts connecting to exterior wall. When using insulated flexible duct, the vapor barrier of the flexible ducts must be taped very tight to prevent condensation problems. To reduce pressure drop, stretch the flex duct and support it in a proper manner to avoid reduced airflow.

When connecting the ERV/HRV to a return-air duct system, insulated flexible duct can be used. However, when metal or rigid ducts are applied use approximately 18-in (457mm) of flexible duct at ERV/HRV ports for fresh-air supply, and stale-air return. When using metal duct from fresh-air supply to system duct work, the metal duct should be insulated. See Fig. 8. This can act as a silencer when connecting ducts to return-air duct system. This should eliminate transmission of noise or vibration from unit to main duct system.

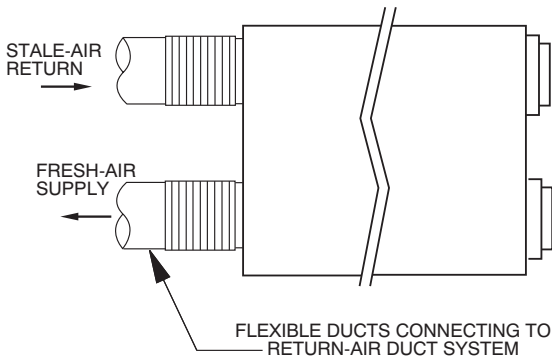

Fig. 8 - Flexible Duct Fit-Up

A08102

Locate and Install Exterior Hoods

IMPORTANT: To prevent condensation problems, insulated flexible ducts are required on both fresh-air inlet and exhaust-air outlet ducts connecting between ERV/HRV and exterior wall.

Fresh-air intake and stale-air exhaust must be separated by at least 6 ft (1.8m). Fresh-air intake must be positioned at least 10 ft (3m) from nearest dryer vent, furnace exhaust, driveway, gas meter, or oil fill pipe. Fresh-air intake must be positioned as far as possible from garbage containers and potential chemical fumes. When possible, it is advised to locate the intake and exhaust hoods on same side of house or building. The intake and exhaust hoods should never be located on interior corners or in dead air pockets. See Fig. 7. Both intake and exhaust hoods must be 18-in (457mm) from ground and at least 12-in (305mm) above anticipated snow level.

After selecting proper hood locations, make appropriate size hole through exterior wall, pass flexible duct through hole and insert hood tube into duct. Tape duct vapor barrier tightly around hood tube and insert assembly back into wall and fasten securely.

Condensate Drain

(For ERV, skip this step and continue to the next step.)

To connect condensate drain, proceed as follows:

1. Punch out holes in foam insulation and door, then insert sleeved grommets into bottom of unit using the gasket washer and nut. See Fig. 9.
2. Cut two sections of plastic tubing, about 12-in. / 305mm long and attach them to each drain.
3. Join the two short sections of plastic tubing to the "T" connector and the main tube as shown.
4. Make a loop in the tubing below the "T" connector to create a trap to prevent sewer gases from entering the ventilation system. See Fig. 9.
5. Connect unit drain to building's main drain. Provide slight slope from unit for run-off.

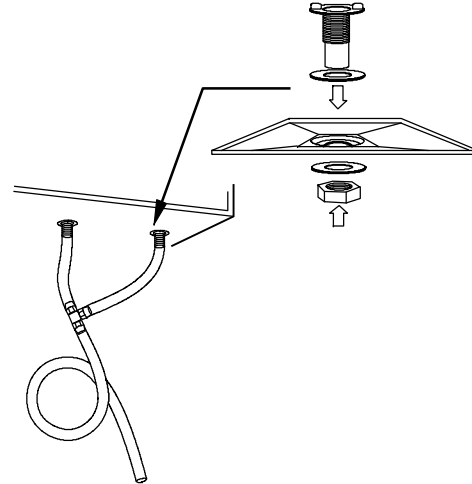

Fig. 9 - Condensate Drain With Loop Trap (HRV Only)

WALL CONTROL

Types

Four remote wall control options are available:

1. Basic Control (see Table 1).
2. OneTouch Control
3. Standard Control (includes dehumidistat)
4. Latent Control (includes humidistat for use with ERV's only)

Table 1 – Basic Control

MODE	OPERATION	DAMPER POSITION	FAN SPEED
Off	Off	Closed to outside	Off
Low	Air exchange with outside	Open to outside	Low
Intermittent	Air exchange with outside	Open to outside	Low
High	Air exchange with outside	Open to outside	High

Location

The Standard Control and the Latent Control sense humidity and not temperature. They must be located in an area where they will continually monitor fresh air circulating within the home. Install ERV/HRV wall controls as close as possible to main system thermostat and follow same guidelines as installing a thermostat (locate approximately 5 ft / 1.5m above floor, mount on an inside partitioning wall, etc.)

Wiring

Remove top cover assembly from wall control and pass thermostat wire through hole located on back of control before attaching to wall. Connect Y, R, G, and B (yellow, red, green, and black) between wall control and ERV/HRV connector following color code. See Fig. 5 and 10. Replace top cover assembly.

NOTE: ERV/HRV wall control and circuit board operate on 12VDC.

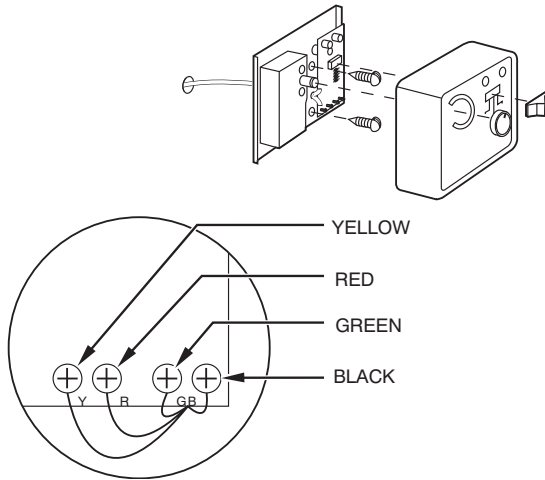

Fig. 10 - Typical Wall Control

A98383

Operation

The Standard and Latent wall controls have 4 basic modes of operation, OFF, LOW, HIGH, and INTERMITTENT. Be sure that all modes of operation are fully functional. See Table 1 indicating standard control operation.

1. With switch off, ERV/HRV is inoperative and the LED is out.
2. With switch on LOW, ERV/HRV continuously exchanges air with outside. If control is satisfied, blower will run in low speed, otherwise, blower will run on high speed. The LED is illuminated all the time.
3. With switch on INTERMITTENT, the ERV/HRV exchanges air with outside on low-speed blower, and unit shuts down when control is satisfied. The ON LED is illuminated all the time, and AIR EXCHANGE LED is illuminated only when unit is running.

Humidity Selector

The humidity selector is a built-in control designed to properly control the level of humidity in the house during the winter and summer months. This control helps avoid condensation problems in upper northern regions where indoor humidity is a problem during the winter season.

NOTE: This control is not to be confused with a dehumidistat used during the summer months to control high relative indoor humidity.

Table 2 recommends humidity levels to avoid condensation.

Table 2 – Recommended Humidity Levels

OUTSIDE TEMPERATURE	DOUBLE-PANE WINDOWS	TRIPLE-PANE WINDOWS
50°F / 10°C	55%	65%
32°F / 0°C	45%	55%
14°F / -10°C	35%	45%
-4°F / -20°C	30%	45%
-22°F / -30°C	25%	35%

OneTouch Control

The OneTouch Control can be used as the primary wall control for the ERV/HRV. This control will step through the modes of operation with consecutive presses of the button. The LED indicates which mode is currently selected, Off, Intermittent, Low, or High.

NOTE: OneTouch Control does not have a humidity selector.

NOTE: OneTouch Intermittent mode exchanges air on low speed for 20 minutes per hour.

Latent Control

NOTE: For Latent Controls used with ERVs, to ensure highest degree of humidity control in cooling season, the INTERMITTENT mode should be used.

Integrated Control

All units are equipped with an integrated control, located under the unit, in front of the electrical compartment. Use the push button (1) to control the unit. The LED (2) will then show on which mode the unit is in. Integrated Control overrides Wall Control function. When LED is off, ventilator responds to Wall Control command. See Fig. 11.

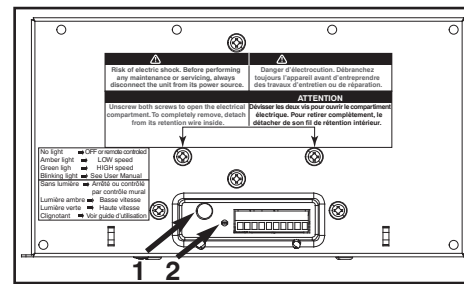

Fig. 11 - Integrated Control

A07260

Refer to table below to see how to operate the unit using its integrated control.

PRESS ON PUSH BUTTON	LED COLOR	RESULTS
Once	Amber	Unit is on Low Speed
Twice	Green	Unit is on High Speed
Three Times	No Light	Unit is OFF

If a problem occurs during the unit operation, its integrated control LED (2) will blink. The color of the blinking light depends on the type of error detected. Refer to Troubleshooting for further details.

NOTE: The ERV/HRV may be controlled using the Infinity/Evolution system control. The ERV/HRV may be connected using either a NIM or a 4-Zone Damper Module. See the appropriate instructions if using the NIM or a 4-Zone Damper Module for connection instructions.

The Infinity/Evolution system control will simultaneously control the ERV/HRV and the indoor blower.

Push Button Timers may be used and are connected to the ERV/HRV. However, the Infinity/Evolution system should be set to continuous fan to ensure that the fresh air is circulated in the home. In a Zoned System, at least one zone should be set to continuous fan.

OPERATING THE ERV/HRV WITH THE INFINITY/EVOLUTION CONTROL

The ventilator has four settings in heating mode and three settings in cooling mode.

Heating:

AUTO – the ventilator selects the speed based on indoor humidity and outdoor temperature. It may cycle on/off every 30 minutes depending on humidity and outside temperature.

LOW – low speed all of the time.

HIGH – high speed all of the time.

DEHUM – will only turn on if humidity is 3% over setpoint. The speed is determined by indoor humidity and outdoor temperature.

Cooling:

AUTO – the ventilator selects the speed based on indoor humidity and outdoor temperature. It may cycle on/off every 30 minutes depending on humidity and outside temperature.

LOW – low speed all of the time.

HIGH – high speed all of the time.

If the fan speed is set to Auto and the ventilator wants to run, the fan speed will run at High continuous speed. Otherwise, the fan will stay at the chosen continuous fan speed.

BOOT SEQUENCE

The unit boot sequence is similar to a personal computer boot sequence. Each time the unit is plugged after being unplugged, or after a power failure, the unit will perform a 30-second booting sequence before starting to operate. During the booting sequence, the integrated control LED will light GREEN or AMBER for 5 seconds, and then will shut off for 2 seconds. After that, the LED will light RED for the rest of the booting sequence. During this RED light phase, the unit is checking and resetting the motorized damper position.

Once the motorized damper position completely set, the RED light turns off and the booting sequence is done.

NOTE: No command will be taken until the unit is fully booted.

ELECTRICAL CONNECTIONS

115-VAC Wiring

The ERV/HRV operates on 115VAC. It comes with a power cord attached to unit and ready to plug into a fused outlet. Unit must be grounded for proper operation.

All electrical connections must comply with National and Local Electrical Codes, or other ordinances that might apply.



WARNING

ELECTRICAL SHOCK / FIRE HAZARD

Failure to follow this warning could result in personal injury, death and/or property damage.

Do not use an extension cord as a power source for operating the ERV/HRV.

12VDC Wiring

The ERV/HRV circuit board, wall control, and accessories operate on 12VDC. See Wall Control section, item Wiring and Fig. 5 and 10 for more information.

ACCESSORIES

20 Minute Timer

A push button timer can be used to override the wall control and put the ERV/HRV into high speed for 20 minutes. Connect switches in parallel and connect leads to ERV/HRV terminals I, OC, and OL. See Fig. 12. Push button locations are ideal in special activity areas, such as, bathroom, or kitchen, where high-speed exhaust operation is needed for a short period of time.

NOTE: The 20 minute timer will not function properly unless ERV/HRV wall control is applied and working correctly. Timing function is internal to electronic circuit board, it is activated by a momentary contact between OC and OL. The I connection is to illuminate the push button. The maximum number of push button timers that can be applied is 5.

60 Minute Adjustable Timer

A 60 minute adjustable timer can also be used to override wall control and put HRV into high-speed operation for a select amount of time. Connect timer in parallel with push button timers, or to ERV/HRV terminals OC and OL. See Fig. 12.

The 60 minute timer will provide a minimum of 10 minutes, and a maximum of 60 minutes of ventilation at high speed.

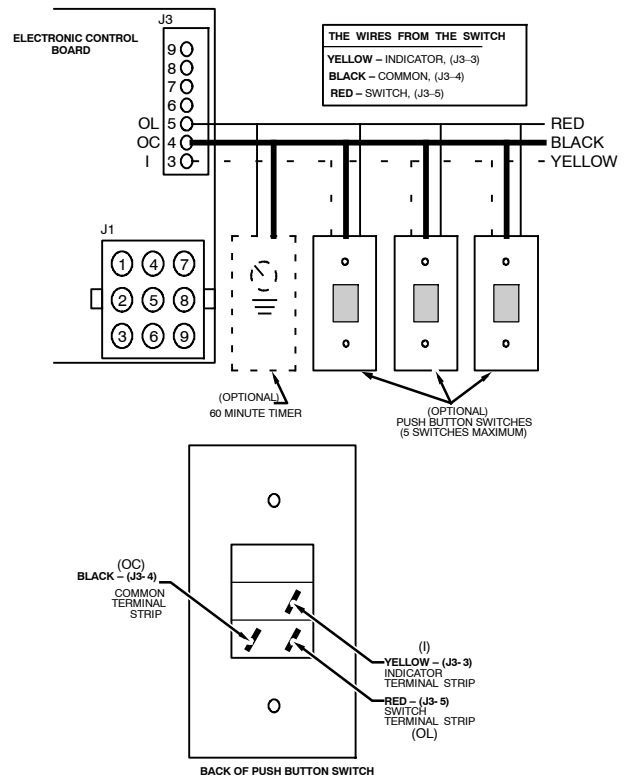
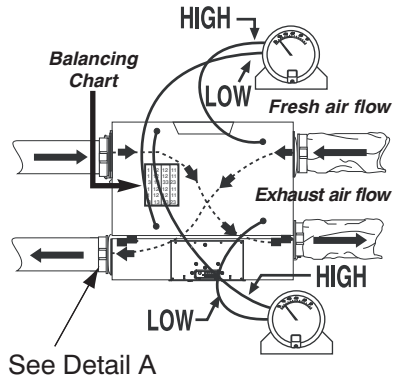

Fig. 12 - Push Button Timer Wiring Layout

A98386

BALANCING ERV/HRV

Balancing intake and exhaust airflow is very important for proper system operation and optimum performance when applying an ERV/HRV. Unit balancing prevents a positive and/or negative pressure within the home. Balancing the ERV/HRV is done by applying magnehelic gauge and using the balancing dampers at the fresh air intake and stale air exhaust ducts. See Fig. 13.



DETAIL A

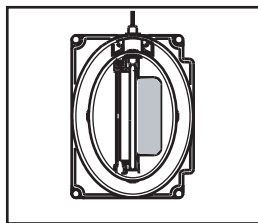

Port with integrated
balancing damper
Top View

Fig. 13 - Balancing ERV/HRV

A07261

Airflow is determined by temporarily connecting a magnehelic gauge to the pressure taps on ERV/HRV. See Fig. 14. Balancing chart is located on unit door.

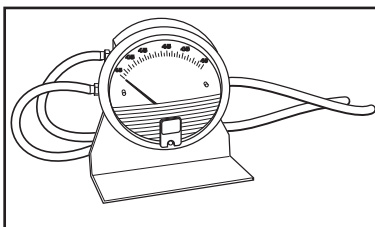

Fig. 14 - Magnehelic Gauge

A98400

If supply-air from outside is greater than exhaust-air from the house, an imbalance can result over pressurizing the home. If exhaust-air is greater than supply-air, combustion appliances may backdraft, bringing exhaust fumes into the house. A balanced condition will ensure optimum performance, provide satisfied customers, and avoid expensive callbacks.

Before proceeding with balancing, all windows, doors, and fireplace flues should be tightly closed. No exhaust systems such as range top exhausts, dryer exhaust, fume hoods, bath or roof fans should be in operation. The forced-air furnace (if used for circulation) should be operating in continuous fan mode for normal operating speed.

Balancing Procedure

Step 1 — Set the unit to high speed.

Make sure that the furnace/air handler blower is ON if the installation is in any way connected to the ductwork of the cold air return. If not, leave furnace/air handler blower OFF. If the outside temperature is below 32°F (0°C), make sure the unit is not running in defrost while balancing. (By waiting 10 minutes after plugging the unit in, you are assured that the unit is not in a defrost cycle.)

Step 2 — Magnehelic gauge placement.

Place the magnehelic gauge on a level surface and adjust it to zero.

Step 3 — Connect tubing from gauge to EXHAUST air flow pressure taps.

Be sure to connect the tubes to their appropriate high/low fittings. See Fig. 13. If the gauge drops below zero, reverse the tubing connections.

NOTE: It is suggested to start with the exhaust air flow reading because the exhaust has typically more restriction than the fresh air, especially in cases of fully ducted installations or source point ventilation. Place the magnehelic gauge upright and level. Record equivalent AIRFLOW of the reading according to the balancing chart.

Step 4 — Move tubing to FRESH air flow pressure taps.

Adjust the fresh air balancing damper until the fresh air flow is approximately the same as the EXHAUST air flow. If fresh air flow is less than exhaust air flow, then go back and adjust the exhaust balancing damper to equal the fresh air flow. See Fig. 13.

Step 5 — Secure both dampers thumb screw in place with tape.

Step 6 — Record air flow information.

Write the required air flow information on a label and stick it near the unit for future reference (date, maximum speed air flows, your name, phone number and business address).

NOTE: The unit is considered balanced even if there is a difference of ± 10 CFM (or ± 5 l/s or 17 m³/h) between the two air flows.

Balancing Dampers

Balancing dampers (sometimes called butterfly dampers) are located in fresh-air intake and stale-air exhaust of the ERV/HRV. See Fig. 13. Insulating over these dampers is strongly recommended after balancing is complete to prevent condensation problems.

VENTILATION EVALUATION

⚠ CAUTION

UNIT DAMAGE HAZARD

Failure to follow this caution may result in reduced unit efficiency, capacity or unit life.

DO NOT use HRV during construction of a house or when sanding drywall. This type of dust may damage system.

Ventilator Sizing

Tables 3 and 4 should be used to determine the required airflow for a home. These guidelines are taken from ASHRAE 62.2–2004.

Table 3 – Ventilation Air Requirements, cfm

FLOOR AREA (ft ²)	BEDROOMS				
	0–1	2–3	4–5	6–7	>7
<1500	30	45	60	75	90
1501–3000	45	60	75	90	105
3001–4500	60	75	90	105	120
4501–6000	75	90	105	120	135
6001–7500	90	105	120	135	150
>7500	105	120	135	150	165

Table 4 – Ventilation Air Requirements, L/s

FLOOR AREA (m ²)	BEDROOMS				
	0–1	2–3	4–5	6–7	>7
<139	14	21	28	35	42
139.1–279	21	28	35	42	50
279.1–418	28	35	42	50	57
418.1–557	35	42	50	57	64
557.1–697	42	50	57	64	71
>697	50	57	64	71	78

CONTROL BOARD OPERATION

Defrost

The ERV/HRV continually monitors the outside air temperature. If the outside air is at or below 23°F (–5°C), the ERV/HRV will initiate a defrost cycle by closing the outside air damper and recirculating warm indoor air through the heat recovery core.

Table 5 – Defrost Schedule

UNIT TYPE	23 to –17°F –5 to –27°C		–17°F and below –27°C and below	
	Frequency	Duration	Frequency	Duration
HRV	25 min.	8 min.	22 min.	10 min.
ERV	28 min.	9 min.	22 min.	10 min.

Off and Intermittent/Off Mode

When ERV/HRV is Off, K1 relay is open, and K5 relay is energized which closes outside air damper.

High-Speed Air Exchange

When high-speed air exchange occurs, K1 and K2 relays are energized and K5 relay is de-energized. This opens low-speed contacts, and closes high-speed contact on K2 relay. This also opens contact on K5 relay which opens outside air damper. Then,

115VAC is applied between orange and gray wires on Molex plug (pins 1 and 6) and blower motor runs in high-speed operation.

Low-Speed Air Exchange

When low-speed air exchange occurs, K1 Relay is energized which closes the contacts. K2 and K5 relays are de-energized. This keeps low-speed contacts closed and high-speed contacts open on K2 relay, and opens outdoor air damper. 120VAC is applied between Red and Gray wires on Molex plug (pins 1 and 4) and blower motor runs in low-speed operation.

CARE AND MAINTENANCE

Door

ERV/HRV door can be removed by unlatching brief case style latches, then slide door to the right and remove it from hinges. Door must be in place and secured shut for proper operation.

Filter

Filters in ERV/HRV are washable and should be cleaned every 3 months. Use a vacuum cleaner to remove heaviest portion of accumulated dust, then wash in lukewarm water. Allow filter to completely dry before reinstalling. A dirty air filter will cause excessive strain on blower motor. Never operate unit without a filter. Vacuum out debris.

In addition, regularly check and clean screens on exterior intake and exhaust hoods when necessary.

⚠ CAUTION

UNIT COMPONENT DAMAGE HAZARD

Failure to follow this caution may result in unit component damage.

DO NOT clean filters in a dishwasher and DO NOT dry them with a heating appliance or permanent damage will result.

Blower Motor and Wheel

ERV/HRV blower motors are factory lubricated for life. Lubricating bearings is not recommended. However, inspect and clean any accumulated dirt and grease from blower motor and wheel annually.

Cleaning the Core

ERV is equipped with a special energy recovery core which utilizes a special membrane and allows transfer of sensible and latent energy. The core should always be vacuumed only every 3 months to remove dust and dirt that could prevent transfer of energy. See Fig. 15 and 16.

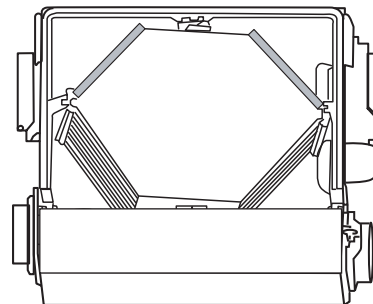
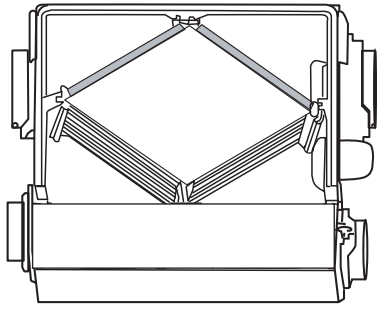

Fig. 15 - ERV Ports on Side (Bottom View)

A05347



A05348

Fig. 16 - HRV Ports on Side (Bottom View)

NOTE: The core should only be serviced when outdoor temperature is 60°F to 75°F (16°C to 24°C) and it is dry.

⚠ CAUTION

UNIT COMPONENT DAMAGE HAZARD

Failure to follow this caution may result in equipment damage or improper operation.

DO NOT use water to clean core or damage will result. In addition, before servicing or removing the core inspect the edges to see if they appear soft (or slightly expanded). This can be normal and due to moisture in the air. **DO NOT** handle or service core until it is dry or air passages can become damaged and/or closed.

⚠ WARNING

ELECTRICAL SHOCK HAZARD

Failure to follow this warning could result in personal injury or death.

Before installing or servicing system, always turn off main power to system. There may be more than 1 disconnect switch.

⚠ CAUTION

CUT HAZARD

Failure to follow this caution may result in personal injury.

Sheet metal parts may have sharp edges or burrs. Use care and wear appropriate protective clothing and gloves when handling parts.

TROUBLESHOOTING

NOTE: Reference Table 6 Troubleshooting Chart

This can be a quick guide in resolving unit problems. It is also recommended to review and understand Wall Control Board Operation and Care and Maintenance sections before continuing.

NOTE: If there is a short circuit or an open circuit at thermistor, CPU will go into a 10 minute defrost cycle every 22 minutes.

Override Test

If desired, the unit can be placed in override test using the procedure below. Override takes priority over a defrost cycle. If using override when outdoor air temperatures call for defrost, the defrost cycle will be temporarily postponed until the override is interrupted or completed.

High Speed

1. Disconnect ERV/HRV from 115VAC.
1. Unplug wall control wires at control module terminal block inside ERV/HRV.
2. Plug ERV/HRV back to 115VAC.
3. Attach a wire across J3-8 and J3-9 (B and G) on control module terminal block.
4. Close door, this will initiate a high-speed exchange.

Low Speed

1. Unplug ERV/HRV from 115VAC.
2. Disconnect wall control wires at control module terminal block inside ERV/HRV.
3. Plug ERV/HRV back to 115VAC.
4. Connect a 3.0 K ohm resistor between B and G on control module terminal block.
5. Close door, this will initiate a low-speed exchange.

Blower Speed Selection

Unit is factory set to the lowest and highest speed. Installer can lower the high speed or increase the low speed, if required. Connections can be changed at transformer location. See Connection diagram, Fig. 17.

Table 6 – Troubleshooting

If the unit does not work properly, reset the unit by unplugging it for one minute and then replug it. If it is still not working properly, refer to table below.

If the integrated control LED of the unit is flashing, this means the unit sensors detected a problem. See the table below to know where the problem occurs on the unit.			
	Error type	Action	Unit status
LED flashes GREEN	Thermistor error	Replace the entire port assembly (fresh air from outside port)	Unit works but will defrost frequently
LED flashes AMBER	Damper error	Go to point 5	Unit does not work
LED flashes RED	<ul style="list-style-type: none"> The door is open and the unit is not unplugged Exhaust motor error 	<ul style="list-style-type: none"> Close the door and press once on the integrated control push button to reset the unit Go to 8 B, C, D, or E 	Unit does not work

	Problems	Possible causes	You should try this
1	The error code E1 is displayed on Altitude or Deco-Touch wall control screen.	<ul style="list-style-type: none"> The wires may be in reverse position. The wires may be broken. The wires may have a bad connection. 	<ul style="list-style-type: none"> Ensure that the color coded wires have been connected to their appropriate places. Inspect every wire and replace any that are damaged. Ensure the wires are correctly connected.
2	There is no outside temperature displayed on Altitude wall control screen 	<ul style="list-style-type: none"> The unit thermistor is defective (the integrated control LED of the unit must flash GREEN). 	<p>NOTE: At its very start-up or after a power failure, it takes some minutes before the outside temperature appears on screen. The delay duration depends on which operation mode the wall control is set. The shortest delay is obtained when the wall control is set on MIN or MAX in VENT Mode.</p> <ul style="list-style-type: none"> Replace the unit thermistor.
3	Altitude or Deco-Touch wall control screen alternates between normal display and E3.	<ul style="list-style-type: none"> The Altitude or Deco-Touch wall control may be defective. 	<ul style="list-style-type: none"> Replace the Altitude or Deco-Touch wall control.
4	Unit does not work.	<ul style="list-style-type: none"> The fuse may be defective. The circuit board may be defective. 	<ul style="list-style-type: none"> Check if fuse F1 (located on PCB) is blown. In that case, replace fuse F1 as per product nameplate. Unplug the unit. Disconnect the main control and the auxiliary control(s) (if need be). Jump G and B terminals. Plug the unit back and wait about 10 seconds. If the motors run on high speed and the damper opens, the circuit board is not defective. 
5	The damper actuator does not work.	<ul style="list-style-type: none"> The damper actuator or the integrated damper port mechanism may be defective. The circuit board may be defective. 	<ul style="list-style-type: none"> Unplug the unit. Disconnect the main control and the auxiliary control(s) (if need be). Wait 10 seconds and plug the unit back. Check if the damper opens. If not, use a multimeter and check for 24 VAC on J12-1 and J12-2 (on circuit board). If there is 24 VAC, replace the entire damper assembly. NOTE: It is normal to experience a small delay (7-8 seconds) before detecting the 24 VAC signal at starting-up. This signal will stay during 17-18 seconds before disappearing. If there is no 24 VAC, replace the circuit board.
6	The wall control does not work.	<ul style="list-style-type: none"> The wires may be in reverse position. The wires may be broken. The wire in the wall OR the wall control may be defective. 	<ul style="list-style-type: none"> Ensure that the color coded wires have been connected to their appropriate places. Inspect every wire and replace any that are damaged. Remove the wall control and test it right beside the unit using another shorter wire. If the wall control works there, change the wire. If it does not, change the wall control.

Table 6 – Troubleshooting (cont.)

	Problems	Possible causes	You should try this
7	The Dehumidistat does not work OR the 20-minute push-button timer does not work OR its indicator light does not stay on.	<ul style="list-style-type: none"> The wires may be in reverse position. The Dehumidistat or push button may be defective. 	<ul style="list-style-type: none"> Ensure that the color coded wires have been connected to their appropriate places. Jump the OL and OC terminals. If the unit switch to high speed, remove the Dehumidistat or push button <small>VE0098</small> and test it right beside the unit using another shorter wire. If it works here, change the wire. If it does not, change the Dehumidistat or push button. 
8	<p>A. The supply motor does not work, but exhaust motor works on both high and low speeds.</p> <p>B. The integrated control LED flashes RED.</p> <p>C. The integrated control LED flashes RED; exhaust motor does not work on both high and low speeds.</p> <p>D. The integrated control LED flashes RED; exhaust motor does not work on low speed but works on high speed.</p> <p>E. The integrated control LED flashes RED; exhaust motor does not work on high speed but works on low speed.</p>	<ul style="list-style-type: none"> The supply motor may be defective. The supply motor capacitor or the PCB may be defective. The door is open and the unit is not unplugged. The exhaust motor may be defective. The exhaust motor capacitor may be defective. The transformer or the PCB may be defective. The 18 μf low speed capacitor wires may have a loose connection. The 18 μf low speed capacitor or the PCB may be defective. The connection between BLUE wire from J9 connector to BLUE wire from transformer may be loose. The transformer or the PCB may be defective. 	<ul style="list-style-type: none"> Plug supply motor to J5 connector and exhaust motor to J4 connector. If the integrated control LED flashes RED, the supply motor is defective. If exhaust motor works, plug back supply motor to J4 connector and exhaust motor to J5 connector, then check for supply motor capacitor validity. Plug supply motor capacitor to J7 connector and exhaust motor capacitor to J6 connector. If the integrated control LED flashes RED, the supply motor capacitor is defective. If there is no change, the PCB is defective. Put a magnet over the door switch or close the door and press once on the integrated control push button to reset the unit. Check both high and low speeds using integrated push button. Plug exhaust motor to J4 connector and supply motor to J5 connector. If supply motor works but exhaust motor does not, exhaust motor is defective. If exhaust motor works, plug back supply motor to J4 connector and exhaust motor to J5 connector, then check for exhaust motor capacitor validity. Plug exhaust motor capacitor to J6 connector and exhaust motor capacitor to J7 connector. If exhaust motor works but supply motor does not, the exhaust motor capacitor is defective. If there is no change, check validity of transformer or PCB. Move JU1 jumper from pins 2 and 3 to pins 1 and 2. Set the unit on high speed (press 2 times on integrated push button, the LED will light GREEN). If exhaust motor works, the transformer is defective. If it still does not, change the PCB. Check both low speed capacitor wires connections. Plug the RED wire from J9 connector to RED wire from transformer. If it works, the 18 μf low speed capacitor is defective. If it is not working, the PCB is defective. Check BLUE wires connection. Move JU1 jumper from pins 2 and 3 to pins 1 and 2. Set the unit on high speed (press 2 times on integrated push button, the LED will light GREEN). If exhaust motor works, the transformer is defective. If it still does not, change the PCB.
9	The defrost cycle does not work (the fresh air duct is frozen) OR the fresh air distributed is very cold.	<ul style="list-style-type: none"> Ice deposit may be hindering the damper operation. The damper rod or the port damper itself may be broken. The damper actuator or circuit board may be defective. 	<ul style="list-style-type: none"> Remove the ice. Inspect these parts and replace if necessary. See point 5.
10	The integrated control push button does not work.	The 30-second boot sequence is not completed.	See Boot Sequence.

Table 7 – Temperature / Ohm Relationship

TEMP. (°F / °C)	RESISTANCE (OHMS)		TEMP. (°F / °C)	RESISTANCE (OHMS)
-9 / -23	78330		46 / 8	19480
-8 / -22	74610		48 / 9	18700
-6 / -21	71100		50 / 10	17960
-4 / -20	67770		52 / 11	17240
-2 / -19	64570		54 / 12	16560
-.4 / -18	61540		55 / 13	15900
1 / -17	58680		57 / 14	15280
3 / -16	55970		59 / 15	14690
5 / -15	53410		61 / 16	14120
7 / -14	50980		63 / 17	13580
9 / -13	48680		64 / 18	13060
10 / -12	46500		66 / 19	12560
12 / -11	44430		68 / 20	12090
14 / -10	42470		70 / 21	11630
16 / -9	40570		72 / 22	11200
18 / -8	38770		73 / 23	10780
19 / -7	37060		75 / 24	10380
21 / -6	35440		77 / 25	10000
23 / -5	33900		79 / 26	9632
25 / -4	32440		81 / 27	9281
27 / -3	31050		82 / 28	8944
28 / -2	29730		84 / 29	8622
30 / -1	28480		86 / 30	8313
32 / 0	27280		88 / 31	8014
34 / 1	26130		90 / 32	7728
36 / 2	25030		91 / 33	7454
37 / 3	23990		93 / 34	7192
39 / 4	23000		95 / 35	6940
41 / 5	22050		97 / 36	6699
43 / 6	21150		99 / 37	6467
45 / 7	20300		100 / 38	6245

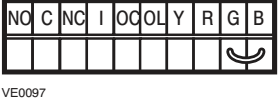
LOGIC DIAGRAM

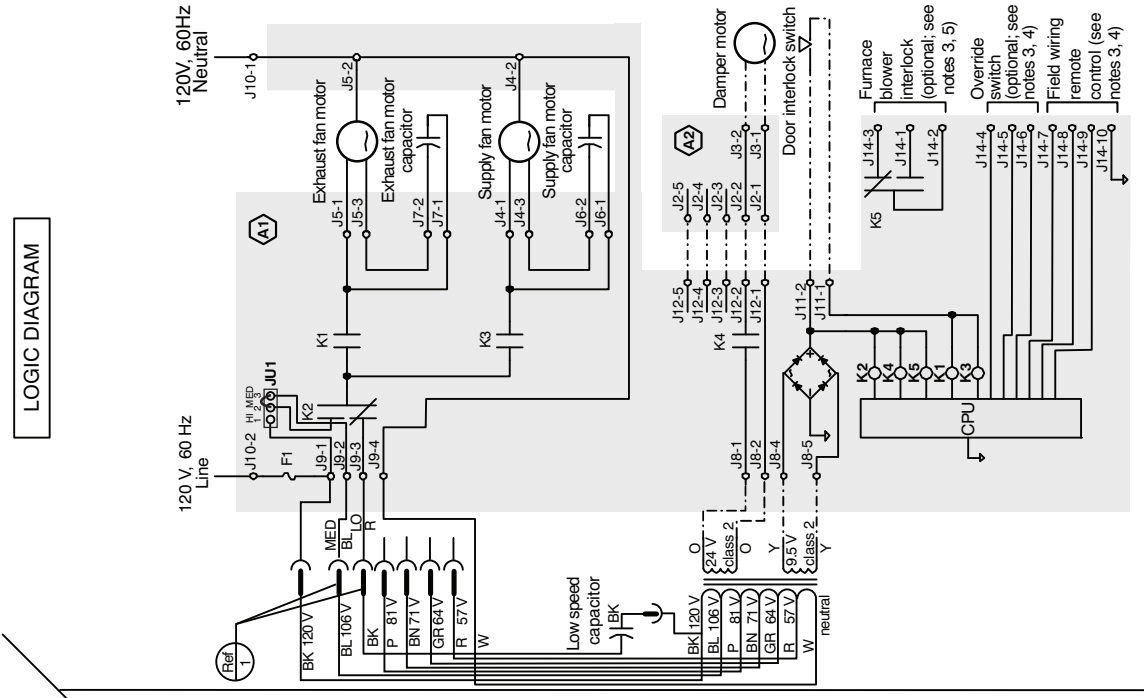

WIRING DIAGRAM

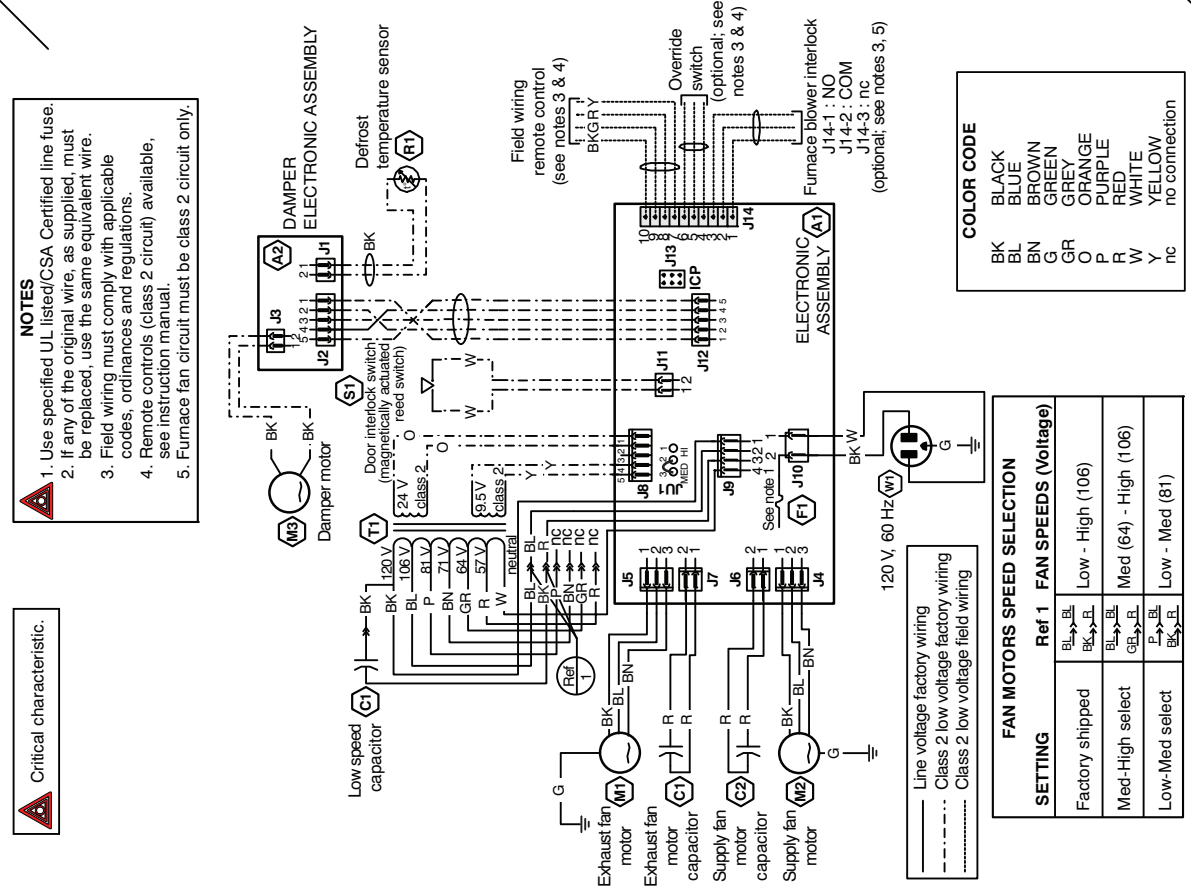

- NOTES**
1. Use specified UL listed/CSA Certified line fuse.
 2. If any of the original wire, as supplied, must be replaced, use the same equivalent wire.
 3. Field wiring must comply with applicable codes, ordinances and regulations.
 4. Remote controls (class 2 circuit) available, see instruction manual.
 5. Furnace fan circuit must be class 2 circuit only.

Critical characteristic:

COLOR CODE

BK	BLACK
BL	BLUE
BN	BROWN
G	GREEN
GR	GREY
O	ORANGE
P	PURPLE
R	RED
W	WHITE
Y	YELLOW
nc	no connection

FAN MOTORS SPEED SELECTION

SETTING	Ref 1	FAN SPEEDS (Voltage)
Factory shipped	BL → BL, BK → BL	Low - High (106)
Med-High select	BL → BL, GR → BL	Med (64) - High (106)
Low-Med select	P → BL, BK → BL	Low - Med (81)

Line voltage factory wiring
 Class 2 low voltage factory wiring
 Class 2 low voltage field wiring

Fig. 17 - ERV / HRV Wiring Diagram

Energy Star (Canada)

- ERVXXSVB1100
- ERVXXSHB1100
- HRVXXSVB1100
- HRVXXSHB1100



These products earned the ENERGY STAR® by meeting strict energy efficiency guidelines set by Natural Resources Canada and the US EPA. They meet ENERGY STAR requirements only when used in Canada.