

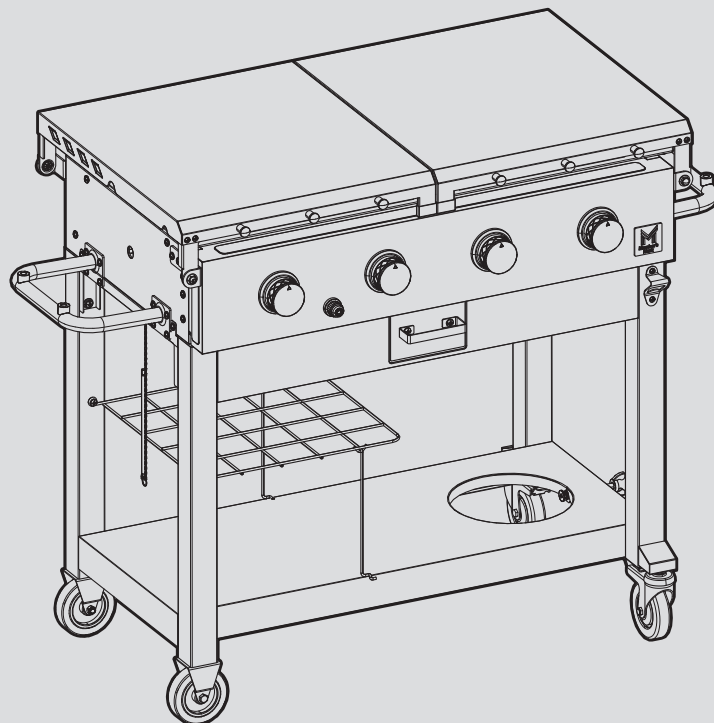

# 4-BURNER GAS GRIDDLE



## Assembly Instructions & User Manual

Model G70204

Scan for easy 3D instructions

Tap. Zoom. Rotate with official interactive instructions on the BILT app.



**BILT**®

Download on the  
App Store

GET IT ON  
Google Play



Quick Start Video  
Scan this QR code.



**STOP**

Do not return this product to the store. If you need help or require parts, call the Customer Care Hotline:

**1-833-454-0864**

This manual must remain with the product at all times.

**FOR OUTDOOR USE ONLY.**

Manual Revision #: 08.16.2024



# IMPORTANT SAFETY WARNINGS

## CAUTION

Read and follow all safety statements, assembly instructions, use and care directions before attempting to assemble and cook.

## INSTALLER OR ASSEMBLER/CONSUMER

This manual should be kept with the griddle at all times.

## WARNING

Failure to follow all of the manufacturer's instructions could result in hazardous fires, explosions, property damage, or serious personal injury or even death.

Follow all leak check procedures carefully prior to operation of griddle, even if griddle was dealer assembled. Do not try to light this griddle without reading the Lighting Instructions section of this manual.

## DANGER

### IF YOU SMELL GAS:

1. **Shut off gas to the appliance.**
2. **Extinguish any open flame.**
3. **Open lid.**
4. **If odor continues, keep away from the appliance and immediately call your gas supplier or your fire department.**

## WARNING

1. **Do not store or use gasoline or other flammable liquids or vapors in the vicinity of this or any other appliance.**
2. **An LP gas cylinder not connected for use shall not be stored in the vicinity of this or any other appliance.**

## CAUTION

IN DIRECT SUN, AND IN OPERATION, YOUR GRIDDLE'S STAINLESS STEEL AND PAINTED STEEL PARTS CAN BECOME VERY HOT.

## CAUTION

Some parts may contain sharp edges, especially as noted in the manual. Wear protective gloves during assembly and usage of this appliance.

For residential use ONLY. Do not use for commercial cooking.

## WARNING

Do not attempt to repair or alter the hose and regulator or valve assembly for any assumed defect or for any type of retro fit or conversion. Any modifications to this assembly will void your warranty and create the risk of a gas leak and fire. Use only authorized replacement parts supplied by the manufacturer for your model.

## TABLE OF CONTENTS:

<b>Installation / Additional warnings</b>	<b>4</b>
<b>Gas Hook-Ups and Warnings</b>	
LP gas cylinder requirements	5
LP gas cylinder removal, transport and storage	6
LP gas cylinder filling	8
<b>Safety Hose and Regulator:</b>	
Connecting regulator to LP gas cylinder	9
Regulator flow limiting device (Propane)	9
Resetting the regulator flow limiting feature	9
<b>Leak Testing</b>	<b>10</b>
<b>Operation - Lighting Instructions</b>	<b>11</b>
<b>Leak Testing - Shut Down Procedure</b>	<b>12</b>
<b>Prevention</b>	
Burner Flame Check	13
Flash-Back Fires	14
<b>Troubleshooting</b>	
Troubleshooting Chart	15
<b>Seasoning Your Griddle Top</b>	<b>17</b>
<b>Care and Maintenance</b>	
Cleaning Your Griddle	18
<b>Storing Your Griddle</b>	<b>20</b>
<b>Start Grilling</b>	
Griddle Cooking Methods	22
<b>Assembly Instructions</b>	<b>25</b>
<b>Warranty and Service</b>	<b>40</b>

### CALIFORNIA PROPOSITION 65 WARNING

 **WARNING:** This product can expose you to chemicals including lead and lead compounds, which are known to the State of California to cause cancer and birth defects or other reproductive harm. For more information go to [www.P65Warnings.ca.gov](http://www.P65Warnings.ca.gov)

 **WARNING:** CONTAINS LEAD. MAY BE HARMFUL IF EATEN OR CHEWED. COMPLIES WITH FEDERAL STANDARDS. KEEP OUT OF REACH OF CHILDREN.

## INSTALLATION

Installation must conform with local codes or, in the absence of local codes, with either the National Fuel Gas Code, ANSI Z223.1/NFPA 54, Natural Gas and Propane Installation Code, CSA B149.1, or Propane Storage and Handling for Recreational Vehicles, ANSI A 119.2/NFPA 1192, and CSA Z240 RV Series, Recreational Vehicle Code, as applicable.

## SETTING UP YOUR GRIDDLE

### Where to Setup Your Griddle

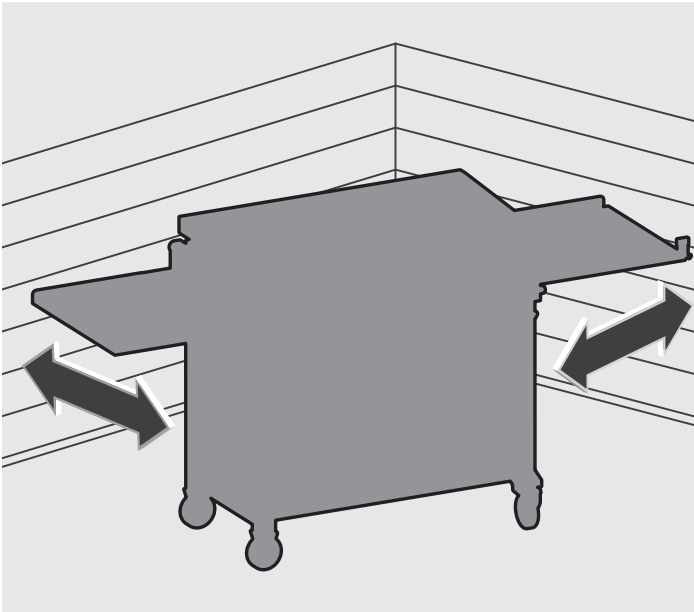

- **For Outdoor use only, in a well-ventilated area.**
- **Minimum clearance to adjacent combustible materials.**
- **MUST** have a clearance of 36" (91.44 cm) on all sides, from a dwelling, walls, aluminum siding, windows, fencing and any other combustible material.
- **MUST NOT** be under any overhang, siding, or other combustible material.
- **NOT FOR** use on any boat or recreational vehicle.
- **DO NOT** use in enclosed spaces such as carport, garage, porch or covered patio.
- **DO NOT** block ventilation holes in the sides or back of barbecue.
- **AVOID** set-up in windy locations.

### OUTDOOR

- An appliance is considered to be outdoors if installed with shelter no more inclusive than with walls on three sides, but with no overhead cover; all openings must be permanently open; sliding doors, garage doors, windows, or screened openings are not considered as permanent openings;
- An appliance is considered to be outdoors if installed with shelter no more inclusive than within a partial enclosure that includes an overhead cover and no more than two sidewalls. The sidewalls may be parallel, as in a breezeway, or at right angles to each other; all openings must be permanently open; sliding doors, garage doors, windows, or screened openings are not considered as permanent openings; or
- An appliance is considered to be outdoors if installed with shelter no more inclusive than within a partial enclosure that includes an overhead cover and three sidewalls, as long as 30% or more of the horizontal periphery of the enclosure is permanently open. All openings must be permanently open; sliding doors, garage doors, windows, or screened openings are not considered as permanent openings.

## GAS HOOK-UP'S AND WARNINGS

### (LP) Liquid Petroleum Gas

- LP gas is nontoxic, odorless and colorless when produced. For your safety, LP gas has been given an odor (similar to rotten cabbage) so that it can be smelled.
- LP gas is highly flammable and may ignite unexpectedly when mixed with air.

### LP Gas Cylinder Requirements:

- Use LP gas cylinder only with these required measurements:  
12" (30.5cm) (diameter) x 18" (45.7 cm) (tall) with 20 lb. (9 kg) capacity maximum.
- LP gas cylinders must be constructed and marked in accordance with specifications for LP gas cylinders of the U.S. Department of Transportation (DOT) or the National Standard of Canada, CAN /CSA-B339, Cylinders spheres and tubes for transportation of dangerous goods. See LP gas cylinder collar for marking.

### **⚠ WARNING**

- (a) Do not store a spare LP-gas cylinder under or near this appliance;
- (b) Never fill the cylinder beyond 80 percent full;
- (c) If the information in "(a)" and "(b)" is not followed exactly, a firecausing death or serious injury may occur.

### Lp Gas Cylinder Rubber Seal Inspection

- Inspect the LP gas cylinder valve rubber seal for cracks, wear or deterioration prior to each use. A damaged rubber seal can cause a gas leak, possibly resulting in an explosion, fire, or severe bodily harm.
- It is recommended that you inspect the rubber seal each time the LP gas cylinder is connected to the appliance, each time it has been refilled, or if it has not been used for more than 60 days.
- DO NOT use a LP gas cylinder with a damaged rubber seal. The rubber seal CANNOT be repaired or replaced. Purchase a new cylinder or exchange the cylinder. You should inspect the seal before accepting a new or exchanged cylinder. DO NOT insert tools or foreign objects into the cylinder valve opening as this could damage the rubber seal.
- The leak check procedure outlined in the product guide/assembly manual MUST be followed each time the LP gas cylinder is connected to the appliance. Consult the product guide/assembly manual for the proper procedure and locations for leak checking.

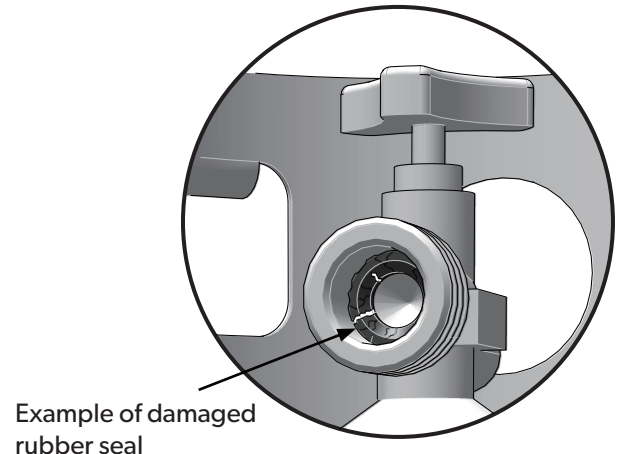
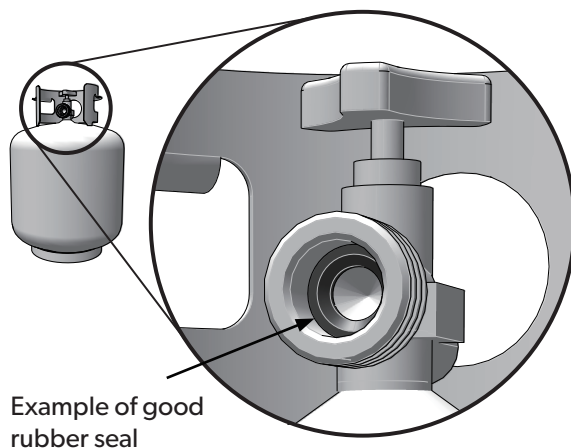

## GAS HOOK-UP'S AND WARNINGS

### LP Gas Cylinder Valve Must Have:

- Shut-off valve with a correct cylinder valve output as specified in current standards.  
CSA/ANSI Z21.58-2022 & CSA 1.6-2022 Outdoor Cooking Gas Appliances.
- Type 1 outlet compatible with regulator or grill. The type 1 valve is easily recognized by the large external thread on the outside of the valve.
- Safety relief valve with direct connection to the vapor space of the LP gas cylinder.
- UL listed Overfill Protection Device (OPD). This OPD safety feature is identified by a unique triangular hand wheel. Use only LP gas cylinder s equipped with this type of valve.
- A device for vapor withdrawal.
- A collar to protect the LP gas tank shut off valve.
- A ring on the bottom of the LP gas tank to secure it to the support assembly.
- Place dust cap on cylinder valve outlet whenever the cylinder is not in use. Only install the type of dust cap on the cylinder valve outlet that is provided with the cylinder valve. Other types of caps or plugs may result in leakage of propane.

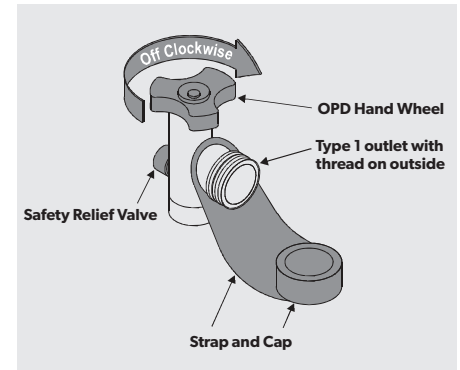

## GAS HOOK-UP'S AND WARNINGS

### ⚠️ WARNING

Any attempt to connect a regulator to any connectors other than the mating TYPE -1 connector could result in fires, explosions, injuries, or property damage. Use only LP gas cylinder equipped with this type of valve.

**DO NOT** connect to a LP gas cylinder exceeding 9.1 kg capacity or use a cylinder with any other type of cylinder valve connection device.

Before opening LP gas cylinder valve, check the coupling nut for tightness.

### ⚠️ DANGER

- NEVER store a spare LP gas cylinder , empty or full, under or near the appliance.
- Do not store objects or materials inside the griddle cart.
- If you see, smell or hear gas escaping, immediately get away from the LP gas cylinder /appliance and call your fire department.
- Always turn LP gas cylinder valve off when the griddle is not in use.
- Always handle the LP gas cylinder valve with the utmost care.
- Always keep the LP gas cylinder in use, securely fastened in an upright position.
- Never expose the LP gas cylinder to direct sunlight or excessive heat.
- Never insert any kind of object into the valve outlet as this may cause damage to the Backcheck. A damaged Backcheck can leak resulting in fires, explosions, property damage, severe injuries or death.
- Do not store an LP gas cylinder in enclosed spaces such as a carport, garage, porch, covered patio or other building. Make sure the storage area has a lot of ventilation.
- Do not store an LP gas cylinder in an area where children play.

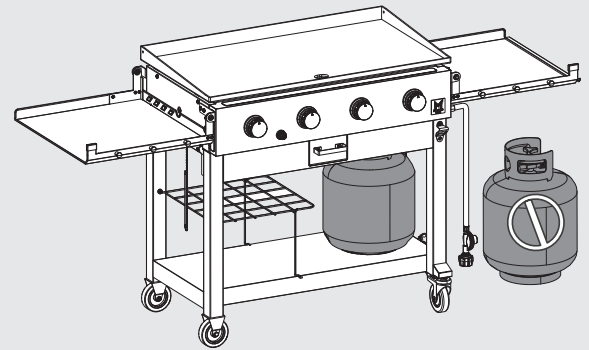

## LP GAS CYLINDER REMOVAL, TRANSPORT AND STORAGE

### Before Disconnecting the LP gas cylinder :

1. Turn "OFF" all control knobs and close the LP gas cylinder valve.
2. Turn coupling nut counterclockwise by hand only - do not use tools to disconnect. Remove LP gas cylinder from inside cart.
3. Install safety cap onto LP gas cylinder valve. Always use cap supplied with tank valve.

### ⚠️ WARNING

FAILURE TO USE SAFETY CAP AS DIRECTED MAY RESULT IN SERIOUS PERSONAL INJURY AND/OR PROPERTY DAMAGE.

### ⚠️ WARNING

- When transporting and storing the LP gas cylinder , make sure it is in an upright position and not on its side. Do not smoke around LP gas cylinder , especially when transporting in a vehicle.
- If storing the griddle indoors, leave the LP gas cylinder outdoors.

## LP GAS CYLINDER FILLING

- Use only licensed and experienced dealers.
- Ensure that the dealer checks and tests the tank for leaks after filling.
- LP dealer must purge new cylinder before filling.
- Dealer should NEVER fill LP gas cylinder more than 80% of LP gas cylinder volume. Volume of propane in cylinder will vary by temperature.
- Do not release liquid propane (LP) gas into the atmosphere. This is a hazardous practice.
- To remove gas from LP gas cylinder, contact an LP dealer or call a local fire department for assistance.

### ⚠ CAUTION

It is important to inspect the cylinder connection device. Check the LP gas cylinder valve rubber seal for cracks, wear or deterioration prior to use. A damaged rubber seal can cause a gas leak, possibly resulting in an explosion, fire, or severe bodily harm. Do not use a propane tank with a damaged rubber seal.

### ⚠ DANGER

- NEVER store a spare LP gas cylinder under or near the appliance, or in an enclosed area.
- DO NOT store an LP gas cylinder in an area where children play.
- LP gas cylinder should only be stored outside and in a cool dry place.
- NEVER expose the cylinder to direct sunlight or excessive heat.
- If you see, smell or hear gas escaping, immediately get away from the LP gas cylinder/appliance and call your fire department.

### ⚠ WARNING

If the information above is not completely adhered to, a fire/explosion causing death or serious injury may occur.

Any attempt to connect a regulator to any connections other than the included connector could result in fires, explosions, injuries, or property damage. Use only LP gas cylinders equipped with this type of valve.

## SAFETY HOSE AND REGULATOR

Your griddle is designed to operate on LP gas at a pressure of 2.74Kpa (11" water column). A regulator preset to this pressure is supplied with your griddle.

### SAFETY FEATURES of QCC-1 Quick Closing Coupling.

All models are designed to be used with an LP gas cylinder equipped with the new QCC-1 Quick Closing Coupling system.

### The QCC-1 System Incorporates SAFETY FEATURES required by the Canadian Standards Steering Committee.

1. Gas will not flow until a positive connection has been made.
2. A thermal element will shut off the flow of gas between 240F and 300°F. This may result in a melted regulator hose.
3. When activated, a Flow Limiting Device will limit the flow of gas to 10 cubic feet per hour.

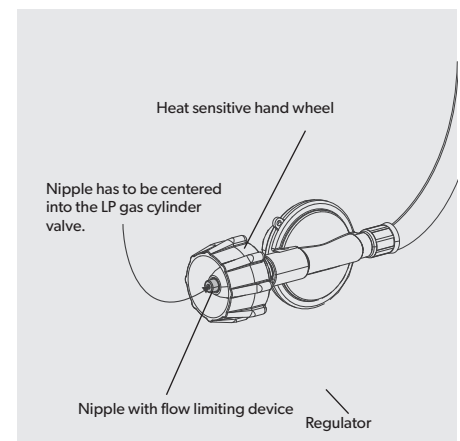

## SAFETY HOSE AND REGULATOR

### Connecting Regulator to the LP Gas Cylinder

1. Turn all control knobs to the "OFF" position.
2. Turn LP gas cylinder "OFF" by turning hand-wheel clockwise to a full stop.
3. Remove the protective cap from LP gas cylinder valve. Always use cap and strap supplied with valve.
4. Hold regulator and insert nipple into LP gas cylinder valve. Hand tighten the coupling nut. Hold the regulator in a straight line with LP gas cylinder valve so as not to cross-thread the connection.
5. Turn the coupling nut clockwise and tighten to a full stop. The regulator will seal on the back-check feature in the LP gas cylinder valve, resulting in some resistance.

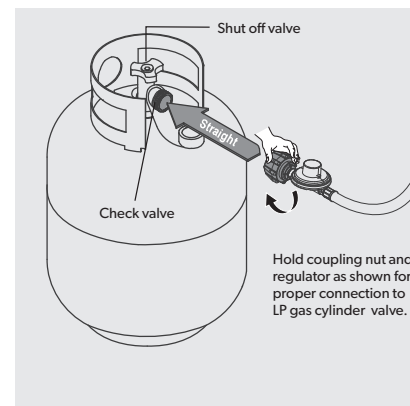

**NOTE:** If you cannot complete the connection, disconnect regulator and repeat steps 4 and 5. If you are still unable to complete the connection, **DO NOT USE THIS REGULATOR!**

### **⚠ DANGER**

**DO NOT** insert any tool or foreign object into the valve outlet or safety relief valve. You may damage the valve and cause a leak. Leaking propane may result in explosion, fire, severe personal injury, or death.

### Regulator Flow Limiting Device

If you are experiencing any of the following performance issues you may have activated the flow limiting feature in your regulator:

- Burners not getting hot enough
- Low or incomplete burner flames
- Low gas pressure
- Burners not staying lit



Flow Limiting Device Video  
Scan this QR code.



### Resetting the Regulator Flow Limiting feature

1. With all control knobs and the gas source in the "OFF" position.
2. Disconnect the hose and regulator from the LP gas cylinder.
3. Turn all control knobs to the "HI" position, and let stand for 1-3 minutes, allowing all excess gas in valves and manifold to dissipate.
4. Turn all control knobs to the "OFF" position.
5. Reconnect the hose and regulator to the LP gas cylinder - Do not cross thread the connection. Hand-tighten only.
6. Check all hose connections to ensure that a positive seal has been made.
7. Slowly open the LP cylinder shut-off valve.

**NOTE:** If the LP gas cylinder is opened too quickly, the flow limiting device in the regulator will activate, limiting the flow of gas from the LP gas cylinder.

8. Wait approximately 5 seconds for the hose and regulator pressure to stabilize (to prevent the flow limiting device feature from being re-activated).
9. Turn the ignition burner control knob, to the "HI" position.
10. Press the electronic ignition button, or use the match and match holder, or a barbecue lighter to ignite the burner.

**AVOID ACTIVATING THE FLOW LIMITING FEATURE** by following the proper start up and shut down procedures and performing a complete leak test and safety check to ensure that there are no leaks in the system, and that a positive connection has been made between the gas source and manifold assembly.

## LEAK TESTING

A leak test is used to determine the integrity of a seal. Before using your gas griddle, perform a leak test on the connection between the grill manifold, regulator and the LP gas cylinder to reduce the risk of serious bodily harm or death from fire or explosion.

### When to perform a leak test:

- After assembling your griddle and before lighting for the first time, even if purchased fully assembled.
- Every time LP gas cylinder is refilled, exchanged or if any of the gas components are disconnected or replaced.
- At least once per year or if your griddle has not been used for more than 60 days.

**Although the gas connections on the griddle are leak tested prior to shipment, a complete leak test must be performed at the installation site. Before each use, check all gas connections for leaks using the procedures listed below:**

1. Create a mixture of 50% water and 50% liquid dishwashing soap.
2. Turn all control knobs to **"OFF"**.
3. Ensure that the regulator is securely connected to LP gas cylinder.
4. Spray a water/soap solution on all connections.
5. Open LP gas cylinder valve by turning hand wheel counterclockwise.

- If you hear a rushing sound, turn gas off immediately. There is a leak at the connection. **CORRECT BEFORE PROCEEDING.**

- If **"growing" bubbles appear**, there is a leak. Close LP gas cylinder valve immediately and re-tighten connections. **If leaks cannot be stopped do not try to repair.** Call for replacement parts. Order new parts by providing the serial number, model number, name and part number of items required (see parts list) to a **MEMBER'S MARK BARBECUE CUSTOMER CARE AGENT: 1-833-454-0864.**

6. Always close LP gas cylinder valve after performing leak test by turning hand wheel clockwise.

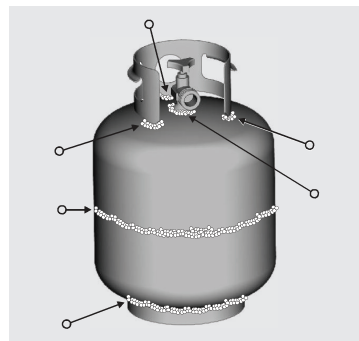

Leaking Test Video  
Scan this QR code.



### **⚠ ATTENTION**

Leak Test must be repeated each time the LP gas cylinder is exchanged or refilled.

- **DO NOT** smoke during leak test.
- **DO NOT** use an open flame to check for gas leaks.
- The griddle must be leak tested outdoors in a well-ventilated area, away from ignition sources such as gas fired electrical appliances.

### **⚠ ATTENTION**

If there is excessive abrasion or wear, or the hose is cut, the hose and regulator must be replaced. Prior to operation.

### **⚠ ATTENTION**

This Member's Mark Griddle is sold propane ready, and is not convertible to natural gas. Any attempt to convert this griddle to natural gas will void the manufacturer's warranty.

## LIGHTING INSTRUCTIONS



Lighting Instruction Video  
Scan this QR code.



### ⚠ WARNING

Before you light this griddle, turn all control knobs to the "OFF" position and close the LP gas cylinder. Failure to follow proper lighting sequence will activate the regulators "FLOW LIMITING DEVICE" feature, and require a reset (See page 9).

### Lighting Burners

1. Open the side shelf tables.
2. Confirm all burner control knobs are turned "OFF." (Push and turn knobs clockwise to ensure "OFF" position).

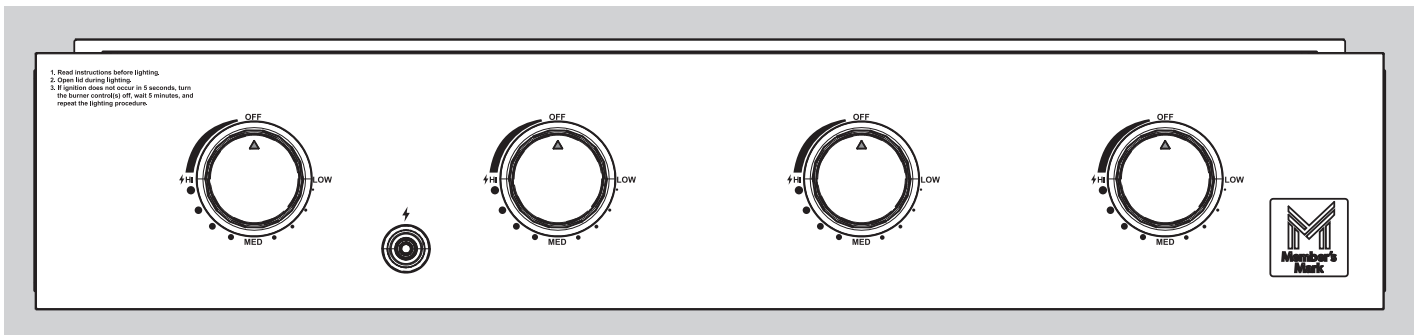

3. Slowly open the LP gas cylinder shut-off valve counter-clockwise. Wait 5 seconds for pressure to stabilize.

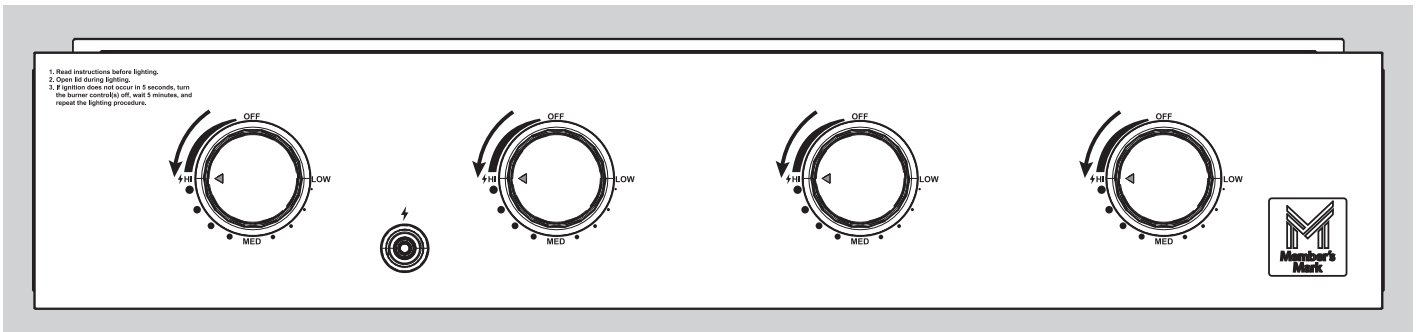

4. Push and turn a control knob counter-clockwise to "HI."
5. Press the electronic ignition button to ignite the burner. Ensure the burner is lit before repeating step 4 for the other burners.

If burners don't light within 3-5 seconds, turn the burner control knob to "OFF" and close the LP gas cylinder valve. Wait five minutes before trying again. This lets released gas dissipate.

### ⚠ WARNING

Never stand with your head directly over the griddle when preparing to light the main burners, to prevent possible bodily injury.

## LIGHTING INSTRUCTIONS

### Match-Lighting — Burners

Repeat **STEPS 1–3 “Lighting Burners”** above.

- For match lighting: Push and turn the far left or far right control knob counter-clockwise to “HI.”
- Immediately place a lit match through the lighting hole on the left or right side of the firebox using the match lighting tool, or use a butane lighter. Confirm that the burner is lit.
- Repeat steps 4 and 5 to ignite the remaining burners.

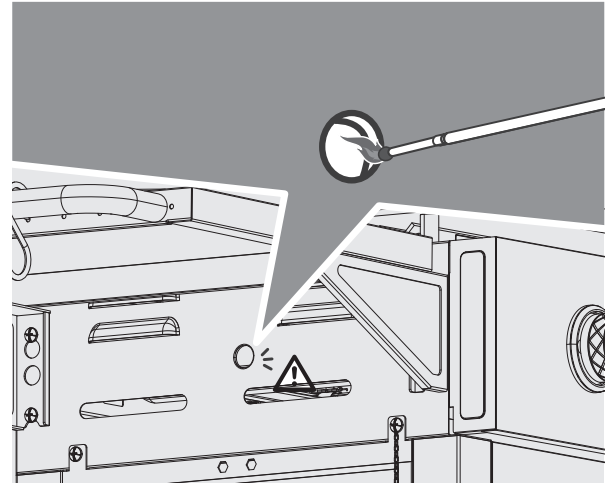

### ⚠ CAUTION

If the ignition **DOES NOT** occur in 5 seconds, turn the control knobs **“OFF”**, wait 5 minutes and repeat the lighting procedure. If the burner does not ignite with the controls on, gas will continue to flow out of the burner and could accidentally ignite with risk of injury. Turn control knobs and gas source **“OFF”** before attempting to re-light.

### ⚠ ATTENTION

Always preheat griddle before starting to cook. Light all burners and adjust them to the **“HI”** position for 10 minutes. Following preheat; adjust the controls to appropriate setting.

### Shut Down Procedure

- Push in and turn each control knob **CLOCKWISE** to the **“OFF”** position ( See image A ).
- Turn LP gas cylinder shut-off valve clockwise to close ( See image B ).

**A**

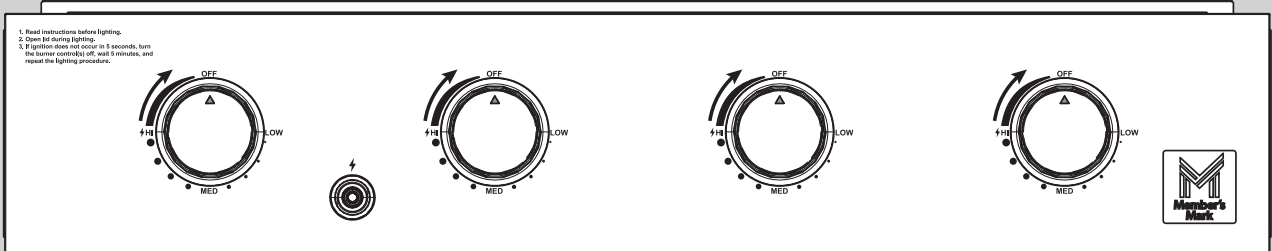

**B**

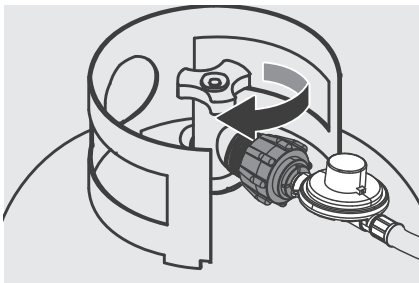

## RESOLVING BURNER ISSUES

### **⚠ ATTENTION**

Once lit, confirm that the burner is properly lit and that the flame pattern is as desired. If the flame pattern is other than normal, consult the troubleshooting guide for corrective action.

### **Burner Flame Check**

The burner flame pattern is the key indicator of proper or improper function within the firebox. When the burners are performing correctly, you will see a specific flame pattern. All burner ports should be 2.5cm/1" flame on **"HI"** with orange tips, light blue center, with dark blue flame at the base of the burner port ( See image C ). Refer to the troubleshooting steps.

Light the burners and rotate the knobs from **"HI"** to **"LOW"**. You should see a smaller flame in low position than seen on high. Perform burner flame check by looking below the griddle top on the side of the unit to view the burners below. Always check the flame before each use. If there is a sudden drop or low flame issue, please refer to the troubleshooting section.

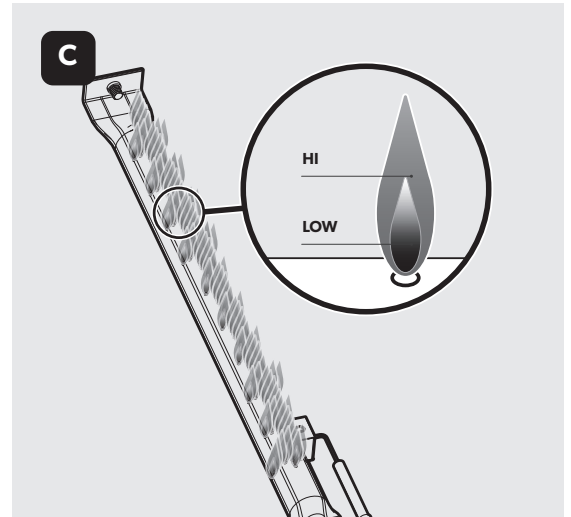

## RESOLVING BURNER ISSUES

### Flash-Back Fires

A flash-back fire occurs when a blockage in the venturi tubes caused by spiders, insects, and nests block the flow of gas, forcing it back towards the control panel and control knob. The ignited gas, if not detected, can cause a fire to burn in this area. **If you experience any of the characteristics of a flash-back fire, close the LP gas cylinder shut-off immediately. Follow the burner cleaning procedure outlined in the maintenance section of this manual.**

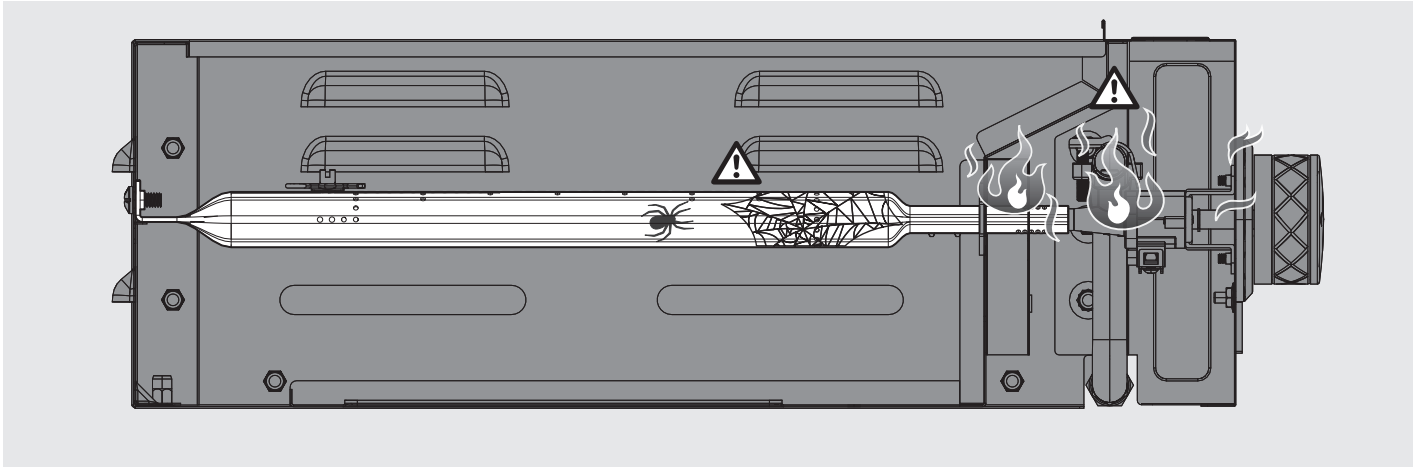

### Characteristics of A Flash-Back Fire

- A fire burning between the firebox and control panel, usually accompanied by **HOT OR MELTING CONTROL KNOBS**.
- Burners may burn with **LARGE YELLOW FLAMES**.
- Burners may not light.

### Prevent Flash-Back Fire

1. After lighting, check for normal burner flames.
2. If irregular flames are found, shut down immediately, and perform maintenance on burners, to remove blockages.
3. If knobs appear hot, shut down immediately, and perform maintenance on burners, to remove blockages.
4. Clean tip of valve gas jet to remove any build-up or blockages.

### **⚠ WARNING**

At first sight of yellow, unruly flames, or poorly lit burners, shut down your griddle and remove and clear obstructions, like insect webs, from your burners and valve gas jet.

### For Your Safety

- **DO NOT** throw water on a fire.
- **DO** keep baking soda handy to extinguish a fire.
- **DO** follow all warnings and safety checks outlined in this **MANUAL**.
- **DO protect your family and home by performing the cleaning and maintenance steps outlined in this manual.**

## TROUBLESHOOTING

PROBLEM	POSSIBLE CAUSES	SOLUTION
Burner will not light (can ignite with a match).	Electrode misaligned.	Electrode should be positioned 1/8" to 1/4" away from the burner tube.
	Battery for the electronic ignition module is dead or missing	Replace battery
	Faulty Ignition .	Contact Customer Support 1-833-454-0864.
Burner will not light (cannot ignite with a match).	Burners are not properly seated over valve orifices. Gas not safely entering burner tube.	Check burners to ensure that they are seated on the valves correctly.
	Positive connection not made between Regulator and Propane tank .	Check all connections between the regulator and propane tank. Ensure a proper seal before retrying.
	Low or out of propane.	Change propane tank and try again.
Burner flames are yellow or irregular.	Blockage in the burner venturi, disrupting the air/gas mixture in the burner.	Clean the burners to remove any obstructions, including but not limited to spider webs. If your burners have bug shields, clean any spider webs, soot, or debris off the bug shield.
Fire behind control panel- Hot or melting control knobs.	Blockage in the Burner venturi, not allowing propane to flow through the burner, forcing flame back towards the control panel. (Flash-back Fire)	Clean the burners to remove any obstructions including spider webs.
	Burner is improperly seated on gas valve.	Check burners to ensure that they are seated on the valves correctly.
Low heat, Low flame or incomplete flame and difficulty lighting both burners (assuming burners and venturi tubes are free and clear of blockages).	All griddle regulators contain a flow limiting device for consumer safety. This device measures the amount of propane going through the regulator to ensure the levels are safe. If the flow rate through the regulator is too high (a symptom of a large leak), the flow limiting device will be triggered, restricting the flow of propane to reduce the chance of a dangerous fire. This safety system can accidentally be tripped by opening a control knob too quickly or connecting the propane tank when a burner control knob has been left open.	This safety system can be reset by moving the burner knobs to the off position and disconnecting the LP gas cylinder from the regulator. Wait five minutes to allow the gas to dissipate. Ensure control knobs are <b>OFF</b> before reconnecting the LP gas cylinder to the regulator. Follow proper lighting procedure.
	LP gas cylinder is empty or low	Refill or replace the LP gas cylinder.
	Regulator stuck in safety position.	Reset the safety by closing both control knobs, removing the propane cylinder and pressure regulator. Check connections for damages, before reconnecting the pressure regulator and propane cylinder. Follow proper lighting procedure.
Flame blows out on "LOW".	Flow limiting device in regulator has been activated either due to a leak or improper lighting.	Perform a leak test before resetting the pressure regulator.
	Low or out of propane.	Replace LP gas cylinder.
	High wind condition	Adjust griddle to shield from wind.
	Burner is improperly seated on gas jet.	Ensure burners are correctly assembled and seated on the gas valves.

## TROUBLESHOOTING

PROBLEM	POSSIBLE CAUSES	SOLUTION
Decreasing heat, "popping sound".	Out of propane.	Refill or replace the LP gas cylinder.
	Burners and/or burner tubes are blocked.	Clean burners.
	Regulator flow limiting device activated either by improper lighting, opening control knobs too quickly, or a poor connection between the griddle and tank.	Reset the pressure regulator.
Humming noise coming from regulator.	LP gas cylinder valve opened too quickly.	N/A
	This is not a defect. It is caused by internal vibrations in the regulator and does not affect performance or safety of the gas grill.	
Rust and corrosion.	Griddle has not been seasoned correctly or the seasoning has worn off.	Properly season the griddle and follow manual instructions for storage, maintenance, and care to prevent rust and corrosion.
Food sticking .	Seasoning has worn off or improper seasoning process.	Ensure proper seasoning of the griddle and adhere to the recommended storage, maintenance, and care instructions provided in this manual.

### CAUTION

Always allow sufficient time for the griddle to cool before handling or cleaning any of its parts.

### WARNING:

Heed the warnings in this manual. Always perform a leak test, every time you refill or change your gas tank. Never leave your propane tank open while not in use. Never leave the control knobs on while not in use.

## SEASONING AND GRIDDLE CARE

### ⚠️ What is seasoning?

Seasoning is the process of applying multiple coatings of oil to the griddle surface, heating to a high temperature, to bake the oil into the griddle top, creating a slick, non-stick surface, that is blackened and protected from rust and oxidation.

### Seasoning Your Griddle

Seasoning your griddle top improves the cooking performance, creates a non-stick surface for cooking, prevents damage and deterioration due to moisture and humidity, and extends the life of your griddle.

### How to Season

1. Clean the griddle top with a damp cloth to remove any dust/dirt.
2. Apply oil to the griddle top, sides and corners. Use a paper towel to coat surface thoroughly.

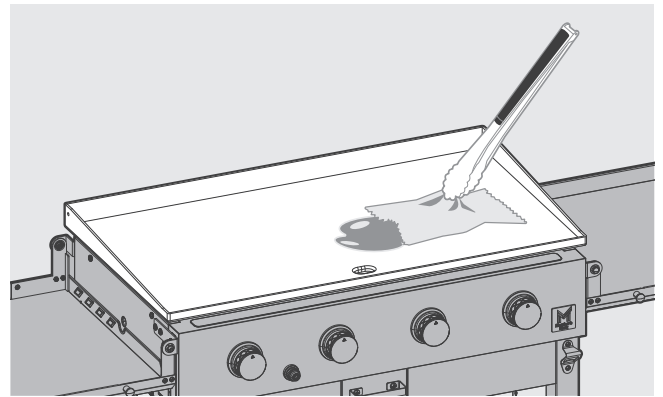
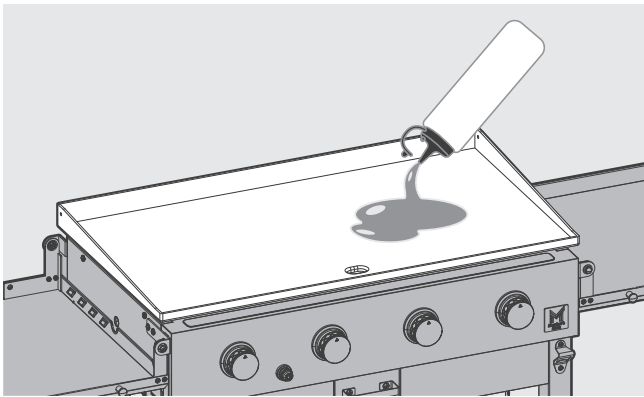

3. Light the griddle and set control knobs to the "HI" setting.
4. Heat the oil to its smoke point. You will notice the griddle top changing color.
5. When the oil stops smoking, repeat steps 2 to 4, about 5 times, until the griddle surface becomes dark.

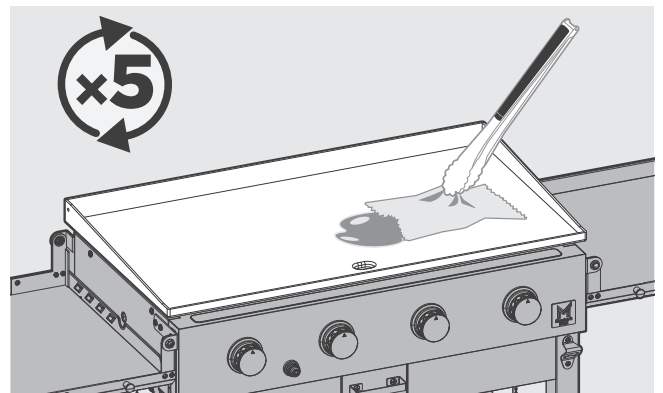
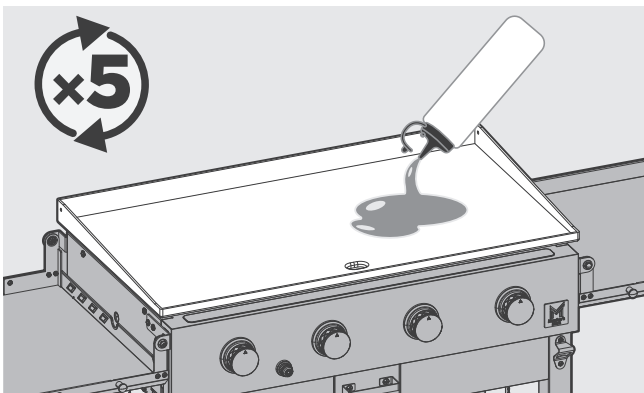
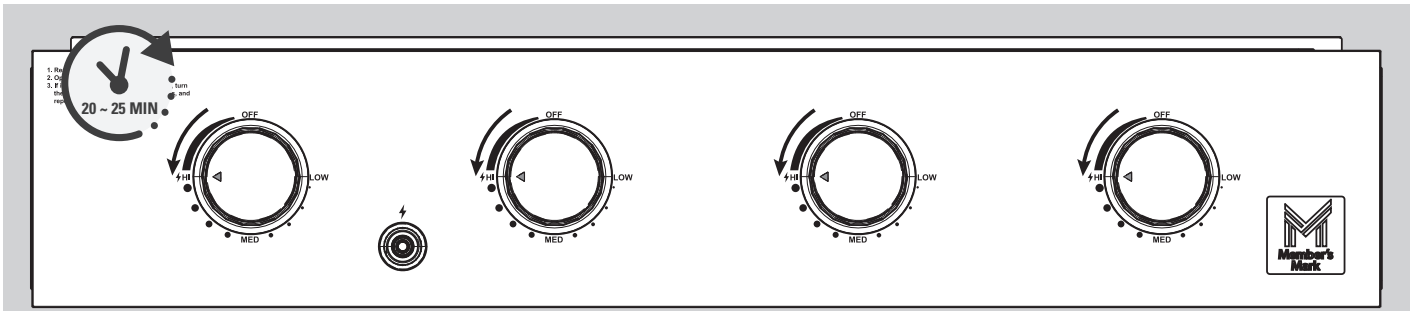

## SEASONING AND GRIDDLE CARE

### Oil's For Seasoning

- Vegetable oil
- Vegetable shortening
- Canola oil
- Flax oil
- Olive oil (Not ideal, as it burns off at lower temperatures than the other options above.)

**DO NOT USE SOAP** on the griddle surface, this will destroy the seasoning.

## CARE AND MAINTENANCE

### ⚠ NOTE

With continued use of your griddle, the seasoning bond will get better and better. Applying a coating of oil at the start and finish of each cook, will help to maintain seasoning. Never use soap to clean the griddle, this will destroy the seasoning. Never pour cold water on surface, as this can cause the surface to warp.

### Griddle Cleaning Tools

You will need:

- PROTECTIVE GLOVES
- CLOTH/ PAPER TOWELS
- SCRAPER
- STEEL WOOL
- WATER BOTTLE
- OIL BOTTLE

### Cleaning Your Griddle

Griddle Surface:

Preheat your griddle. Use a water bottle to squirt the griddle surface. Use a griddle scraper to loosen any debris on the surface. Apply more water if needed. Be careful not to use too much water, as you may overflow the grease catch. Once the griddle top is reasonably clean, scraped and dry, apply a thin coat of oil to maintain the seasoning bond and prevent rust.

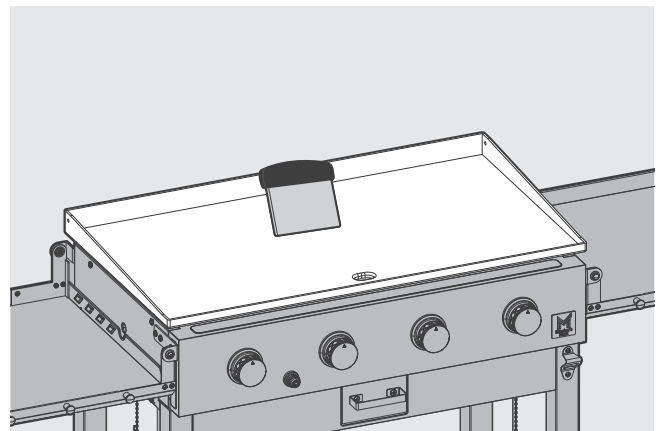
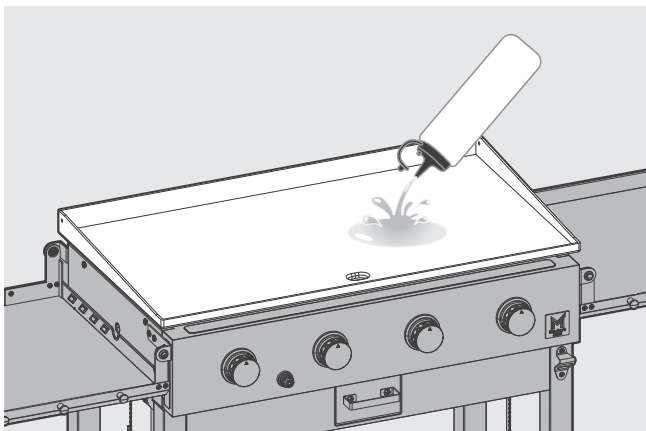

## CARE AND MAINTENANCE

### Burners & Firebox Maintenance

Although your griddle's firebox is fully protected from grease and other build-up that can accumulate during cooking, regular checks of the burners and ignition electrode are still required to ensure proper performance, safety and a longevity of your parts.

#### Burners

Because the burners are covered by the griddle top, it is not as easy to identify poor performance and premature aging of parts.

For this reason, we recommend that once a season the griddle top is removed and burner maintenance conducted.

1. Remove griddle top. Place on the ground, right side up.
2. Remove hitch pins/screws to free the burners. Use WD40 and a screwdriver/pliers to make this removal easier.
3. Remove burners.
4. Use a flexible venturi brush to clean the interior of the burners. Ensure you enter the burner far enough to remove any spider webs and nests that may be present.
5. Use a wire or paper clip to clean any blocked burner ports.
6. Brush away any rust or corrosion from the burners surface, and wipe clean with a damp cloth. Dry the burners.
7. Re-install the burners. Ensure that the burners are properly seated on the valve gas jet before assembling hardware.

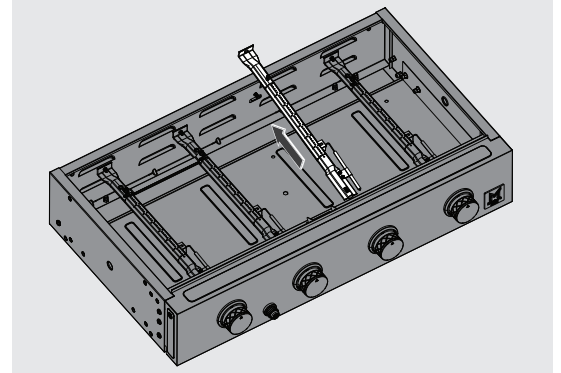

#### **⚠ NOTE**

Before reinstalling burners, use a cotton swab to clean the valve gas jet.

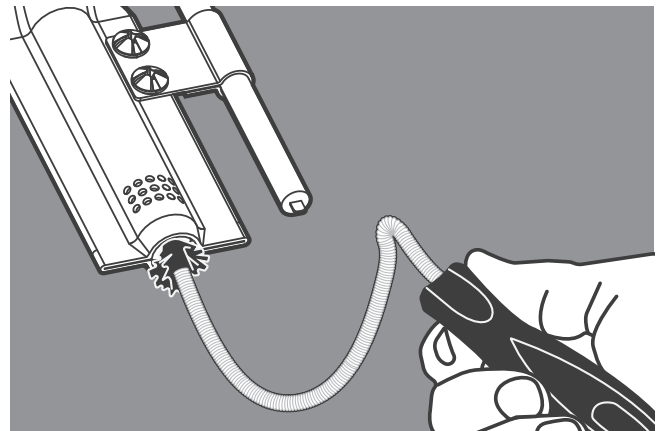
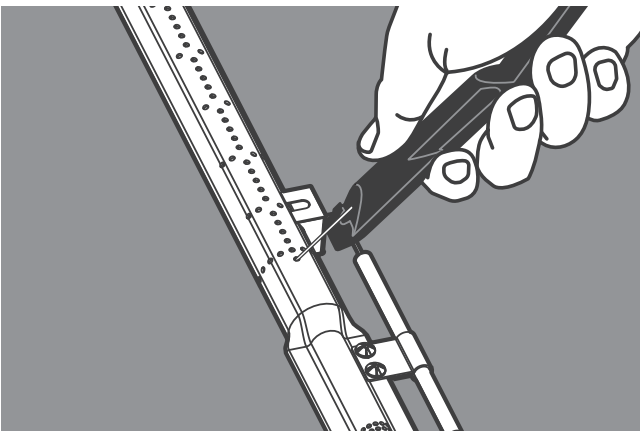

## CARE AND MAINTENANCE

### Cleaning Exterior Parts, and Surfaces

ALL MATERIALS including stainless steel, porcelain, and painted steel parts can become stained, soiled and corroded by dirt, pollution, deposits from inappropriate cleaners and grease. Routine cleaning of exterior surfaces is necessary to remove contaminants, rust and avoid permanent damage.

Do's :

- **DO** remove dirt and contamination immediately to avoid permanent damage to porcelain, or painted surfaces.
- **DO** wipe down all surfaces frequently with a basic vinegar and water solution, or basic warm water and detergent.
- **DO RINSE OFF** all cleaners, with clean warm water, and dry completely with a soft or microfiber cloth.
- **DO NOT** use any chloride-containing detergents, abrasive cleaners, bleach or other chemical cleaners as they may permanently damage painted surfaces.

### Fold-Over Side Shelves

The fold-over side shelves serve to provide additional protection for the griddle surface against rainwater and snow. However, please note that while the side shelves offer extra shielding, they may not completely prevent rainwater, moisture, animals, or insects from reaching the griddle surface.

For proper care:

- Always fold down the side shelves when storing to safeguard the griddle surface.
- Use the provided grill cover to protect the griddle.
- Store the griddle in a sheltered area, away from direct exposure to rain and snow.
- Before storage, ensure your griddle is seasoned to prevent rust and corrosion during periods of non-use.

### Storing Your Griddle

- If possible, always store in a cool, dry location.
- If storing with the LP gas cylinder, store outdoors in a well-ventilated area.
- If storing for long periods of time, make sure that the griddle top is fully seasoned and protected.
- Always cover your **griddle** with a full length, all weather grill cover, to protect from all elements.

#### **⚠ CAUTION**

Only cover the griddle and griddle top when fully cooled.

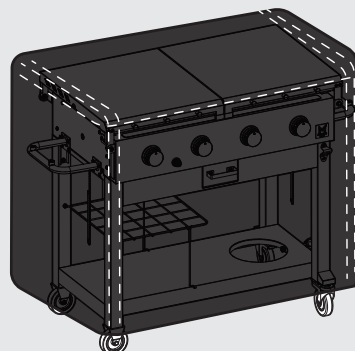

**CARE AND MAINTENANCE****⚠ GENERAL GRIDDLE SAFETY TIPS ⚠**

1. **ALWAYS** turn control knobs and LP gas cylinder **"OFF"** when not in use.
2. **DO NOT** leave griddle unattended at any time while in operation.
3. If the griddle surface and components have not been regularly maintained or safely checked, take extreme caution at first lighting, during preheat, and when cooking at high temperatures.
4. Never move the griddle while in operation or still hot.
5. All surfaces in and around the griddle can become **HOT** to the touch. Keep children and pets away. Do not allow people to congregate around the griddle. Always use long-handled barbecue utensils and grilling gloves to avoid burns and protect from grease splatters.
6. **DO NOT** overload side shelf (**Load capacity 10 lbs**).
7. Each side shelf has a **MAXIMUM CAPACITY of 10kg (22lbs)**. **DO NOT** lean or sit on the side shelves.
8. The grease catch must be in position before cooking.
9. Always empty the grease catch after every cook. Do not remove the grease catch until it has completely cooled.
10. Clean griddle often, preferably after each cookout.
11. Perform a leak test every time you change your LP gas cylinder .
12. Inspect your griddle's hose and regulator or any cracks, tears or damage caused by rodents. If unsure, perform a leak test to ensure your families safety.
13. If the regulator frosts, turn off the griddle and LP gas cylinder valve immediately. This indicates a problem with the cylinder and it should not be used on any product. Return to supplier!
14. Never position any flammable, or temperature sensitive items on the side shelf or close to the griddle surface, as they may overheat and result in an explosion, fire, severe personal injury, or death.
15. Do not use water on a fire. If a fire develops, and it is safe to do so, turn the LP gas cylinder **"OFF"** and disconnect it. Wait for the fire to go out before turning the control knobs **"OFF"**.
16. Do not close the storage lid while the griddle is hot or in use.
17. Minimum ambient operating temperature: 0°F (-18°C).

## START GRILLING

### **WARNING**

Always observe safe food handling and safe food preparation practices when using this griddle, to prevent food-borne illnesses.

### **WARNING**

To ensure that it is safe to eat, food must be cooked to the minimum internal temperatures listed in the table below.

USDA Safe Minimum Internal Temperatures	
Fish	145° F
Pork	160° F
Egg Dishes	160° F
Steaks and Roasts of Beef, Veal or Lamb	145° F
Ground Beef, Veal or Lamb	160° F
Whole Poultry (Turkey, Chicken, Duck, etc.)	165° F
Ground or Pieces Poultry (Chicken Breast, etc.)	165° F

USDA Food Safety and Inspection Service



# **WARNING:** HOT SURFACES

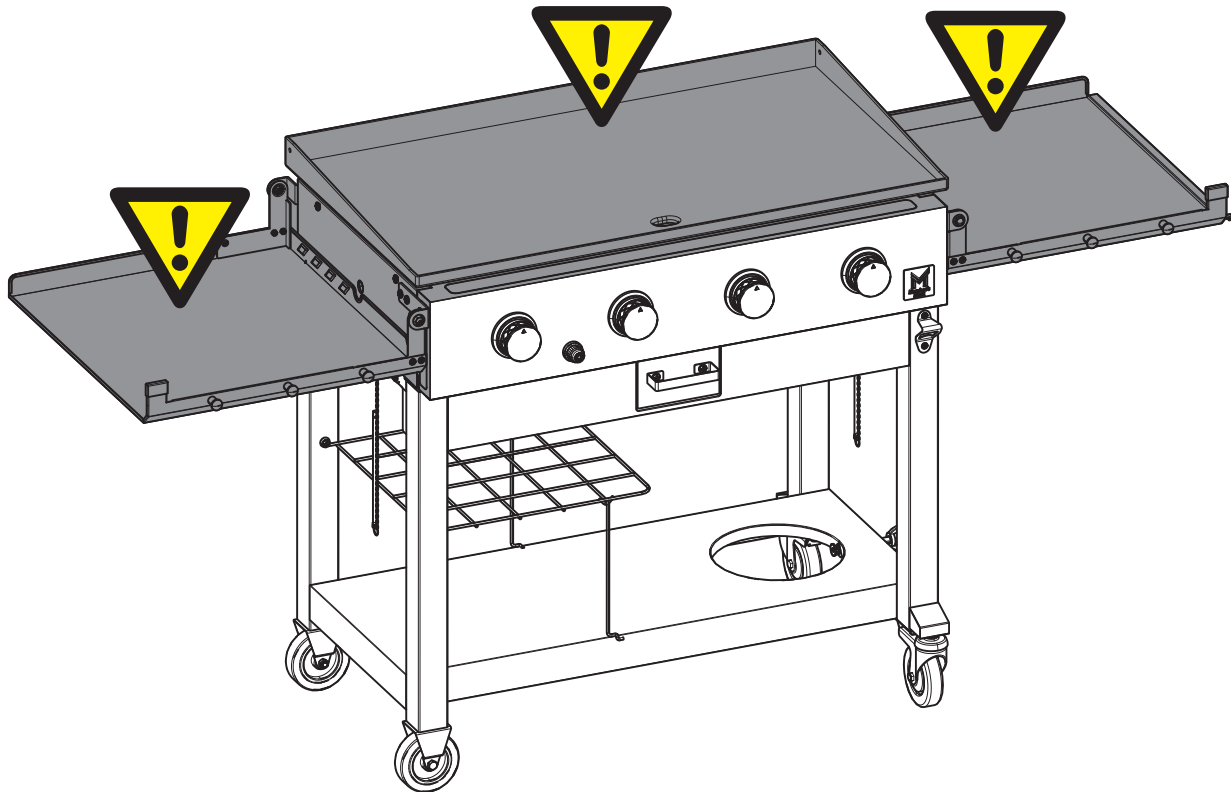

## **WARNING**

**EXTERIOR SURFACES WILL BECOME VERY HOT.**

**TO PREVENT BURNS, ALWAYS WEAR INSULATED PROTECTIVE GRILLING MITTS  
WHEN WORKING AT THE GRIDDLE.**

- **KEEP AWAY FROM COMBUSTIBLE MATERIALS**
- **KEEP CHILDREN AND PETS AWAY FROM THIS GAS FIRED APPLIANCE**
- **AVOID DANGEROUS FIRES: DO NOT LEAVE YOUR GRIDDLE UNATTENDED WHILE IN OPERATION**
- **DO NOT CLOSE THE STORAGE LID WHILE THE GRIDDLE IS HOT OR IN USE. EACH SIDE SHELF HAS A MAXIMUM CAPACITY OF 10KG (22LBS). DO NOT LEAN OR SIT ON THE SIDE SHELVES.**

Scan for easy 3D instructions



**Tap. Zoom. Rotate** with official interactive instructions on the BILT app. Download now for faster setup.

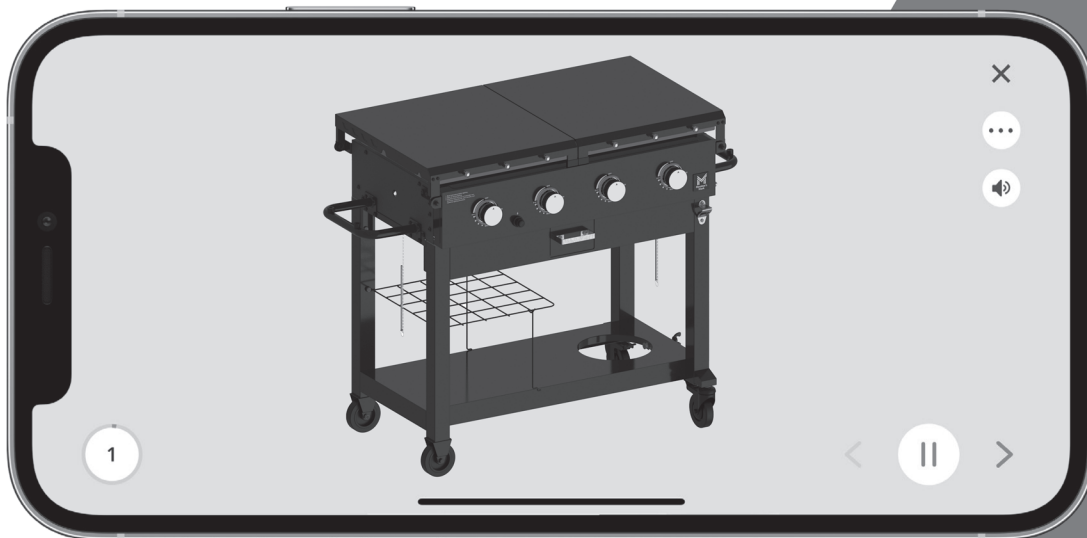





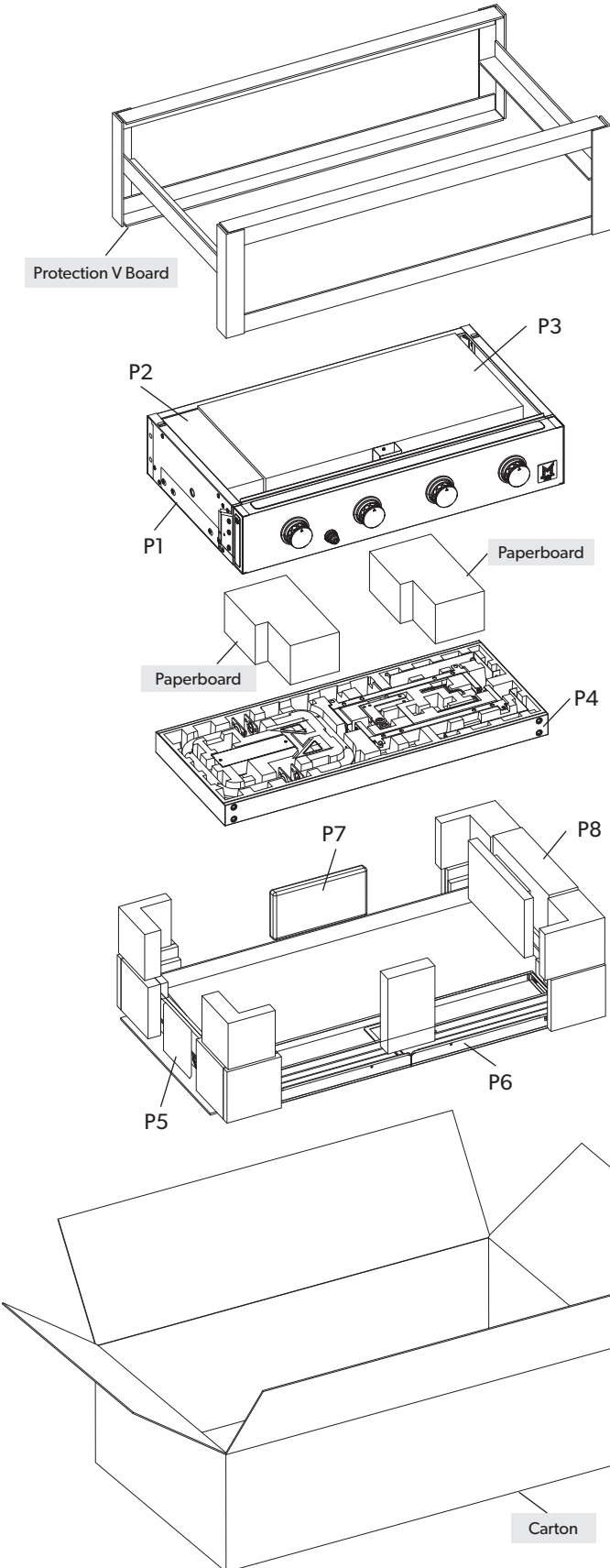

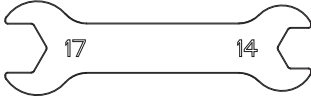

**BILT.**<sup>®</sup>

# PACKAGE CONTENTS

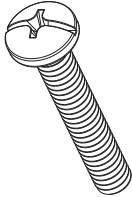

Component	Description	Qty
P1	Firebox Assembly	1
P2	Grease Catch	1
	Foil Insert	3
	Griddle Scraper	1
P3	Tank Heat Shield	1
	Cart Leg	4
P4	Side Shelf, Front Bracket	2
	Bottom Shelf	1
	Tool Hook	6
	Side Shelf, Rear Bracket	2
	Bottle Opener	1
	Brace Support, Back	2
	Triangle Support	2
	Upper Cart Brace	2
	Side Shelf Handle	2
	Grease Catch, Support	2
	Grease Drain Tube	1
	Tank Screw	1
	Brace Support, Front	2
	P5	Hardware Pack
P6	Griddle Top	1
	Front Cart Brace	1
	Side Shelf	2
	Storage Rack	1
P7	Cover	1
P8	Caster	2

# HARDWARE PACK

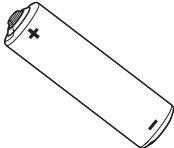
Key	Description	Picture	Qty
A	Wrench		1
B	1/4"-20UNC x 13 Screw		66
C	Tapping Screw		2
D	NO.10-24UNC x 13 Screw		20
E	NO.10 Nut		10
F	1/4"-20UNC x 38 Screw		4
G	1/4" Screw		4
H	Washer		4
I	1/4" Nut		4
J	AA Battery		1
K	Extra Hardware		

## TOOLS REQUIRED

  
Screwdriver  
(Not Included)

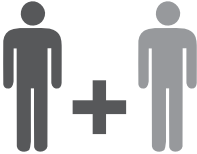
  
2 people

# EXPLODED DIAGRAM

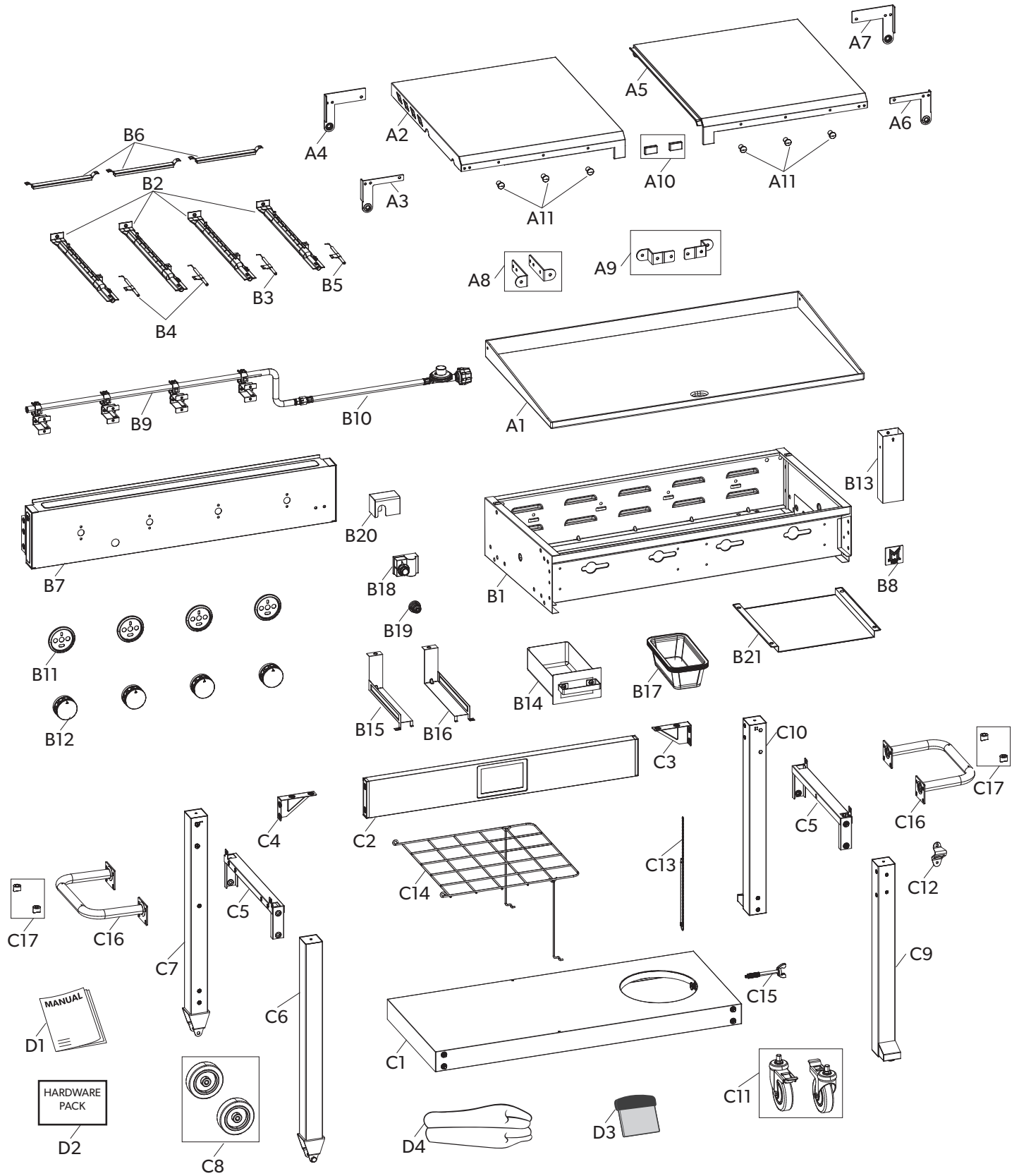

## PARTS LIST

Key	Qty	Description	Part No.
A1	1	Griddle Top	G702-9900-C1
A2	1	Left Side Shelf	G702-1A01-C1
A3	1	Left Side Shelf, Front Brace Support	G702-1A02-C1
A4	1	Left Side Shelf, Rear Brace Support	G702-1A03-C1
A5	1	Right Side Shelf	G702-1C00-C1
A6	1	Right Side Shelf, Front Brace Support	G702-1B01-C1
A7	1	Right Side Shelf, Back Brace Support	G702-1B02-C1
A8	2	Side Shelf, Front Bracket	G702-0006-C1
A9	2	Side Shelf, Rear Bracket	G702-0007-C1
A10	2	Side Shelf, Rubber Cover	G702-1A04-C1
A11	6	Tool Hook	G360-0016-C1
B1	1	Firebox	G702-9000-C1
B2	4	Burner	G702-1200-C1
B3	1	Electrode Set B	G702-9101-C1
B4	2	Electrode Set A	G702-9201-C1
B5	1	Electrode Set C	G702-9301-C1
B6	3	Carryover Assembly	G515-0044-C1
B7	1	Control Panel	G702-8800-C1
B8	1	Logo Plate	G702-9402-C1
B9	1	Manifold Assembly	G702-1500-C2
B10	1	Regulator	G702-1403-C1
B11	4	Control Knob Bezel	G329-0503-C1
B12	4	Control Knob	G561-0007-C1
B13	1	Grease Drain Tube	G556-4301-C1
B14	1	Grease Catch	G702-9700-C1
B15	1	Grease Catch, Left Support	G702-4903-C1
B16	1	Grease Catch, Right Support	G702-4904-C1
B17	3	Foil Insert	G703-0607-C1
B18	1	Electronic Ignition Module	G602-0006-C1
B19	1	Electronic Ignition Module Cap	G409-0030-C1
B20	1	Heat Shield, Electronic Ignition	G502-0066-C1
B21	1	Tank Heat Shield	G702-8901-C1
C1	1	Bottom Shelf	G702-8700-C1
C2	1	Front Cart Brace	G702-3800-C1
C3	1	Triangle Support, Left	G702-0803-C1
C4	1	Triangle Support, Right	G702-0802-C1
C5	2	Upper Cart Brace	G702-1E00-C1
C6	1	Front Cart Leg, Left	G702-8200-C1
C7	1	Back Cart Leg, Left	G702-8300-C1

Key	Qty	Description	Part No.
C8	2	Wheel	G702-0203-C1
C9	1	Front Cart Leg, Right	G702-8500-C1
C10	1	Back Cart Leg, Right	G702-8600-C1
C11	2	Locking Caster	G473-0017-C1
C12	1	Bottle Opener	G651-0013-C1
C13	1	Match Holder	G329-0002-C2
C14	1	Storage Rack	G702-8001-C1
C15	1	Tank Screw	G325-5403-C1
C16	2	Side Shelf Handle	G702-1D00-C1
C17	4	Rubber Cap, F/Side Shelf Handle	G702-0008-C1
D1	1	Assembly And Use Manual	G702-040801-C1
D2	1	Hardware Pack	G70204-B001-C1
D3	1	Griddle Scraper	G703-0016-C1
D4	1	Cover	G702-0009-C1

# ASSEMBLY INSTRUCTIONS

## 1

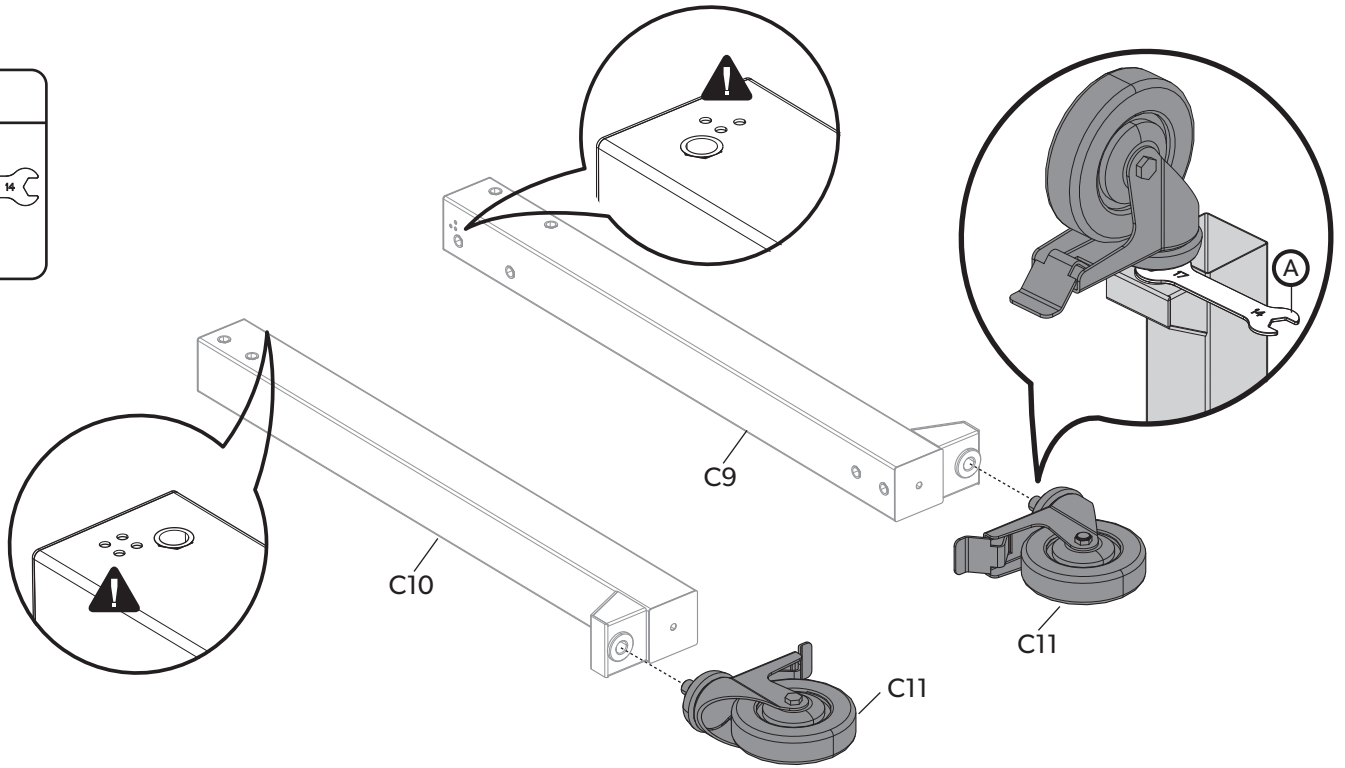
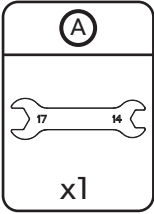

## 2

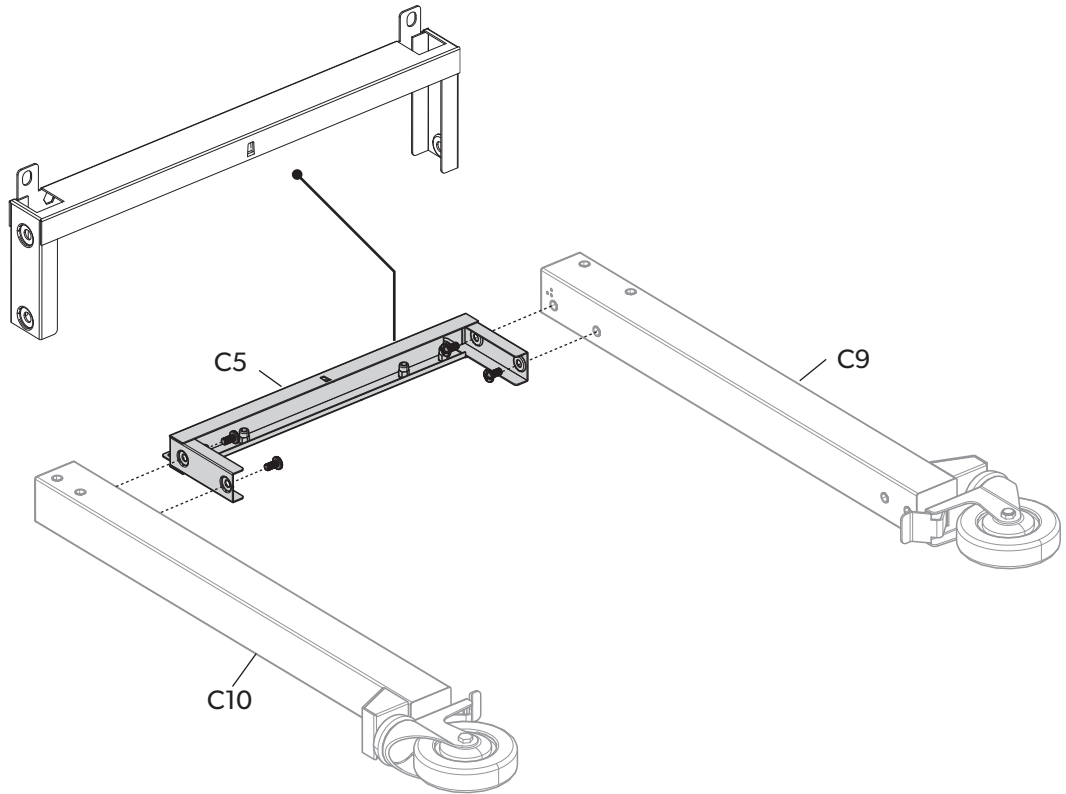
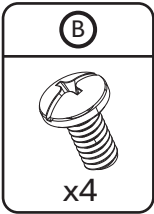

# ASSEMBLY INSTRUCTIONS

**3**

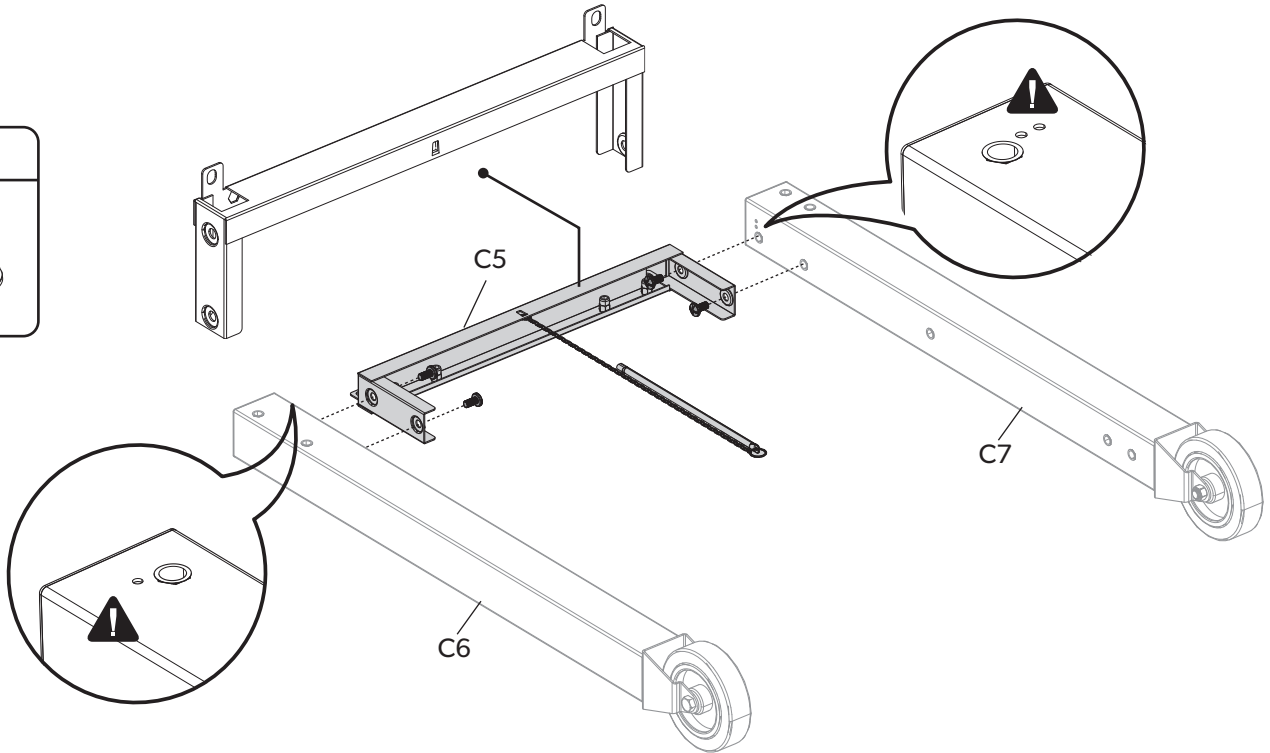
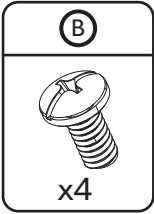

**4**

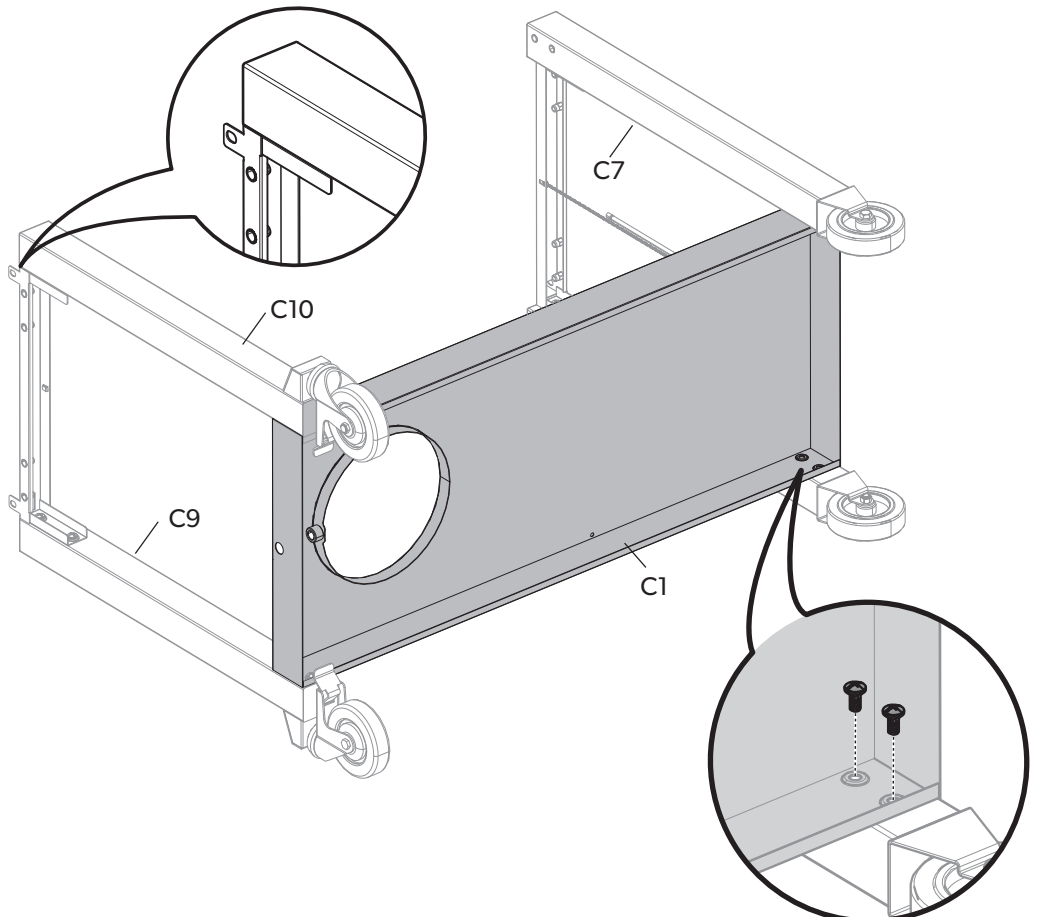
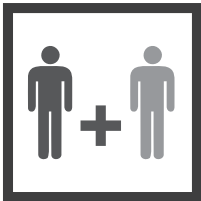
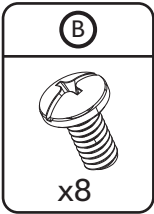

# ASSEMBLY INSTRUCTIONS

## 5

1ST

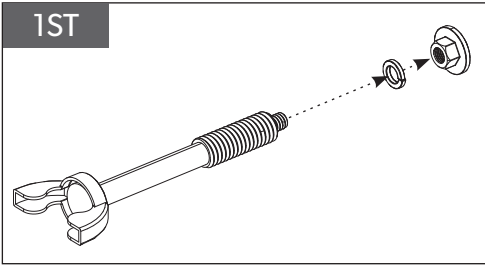

2ND

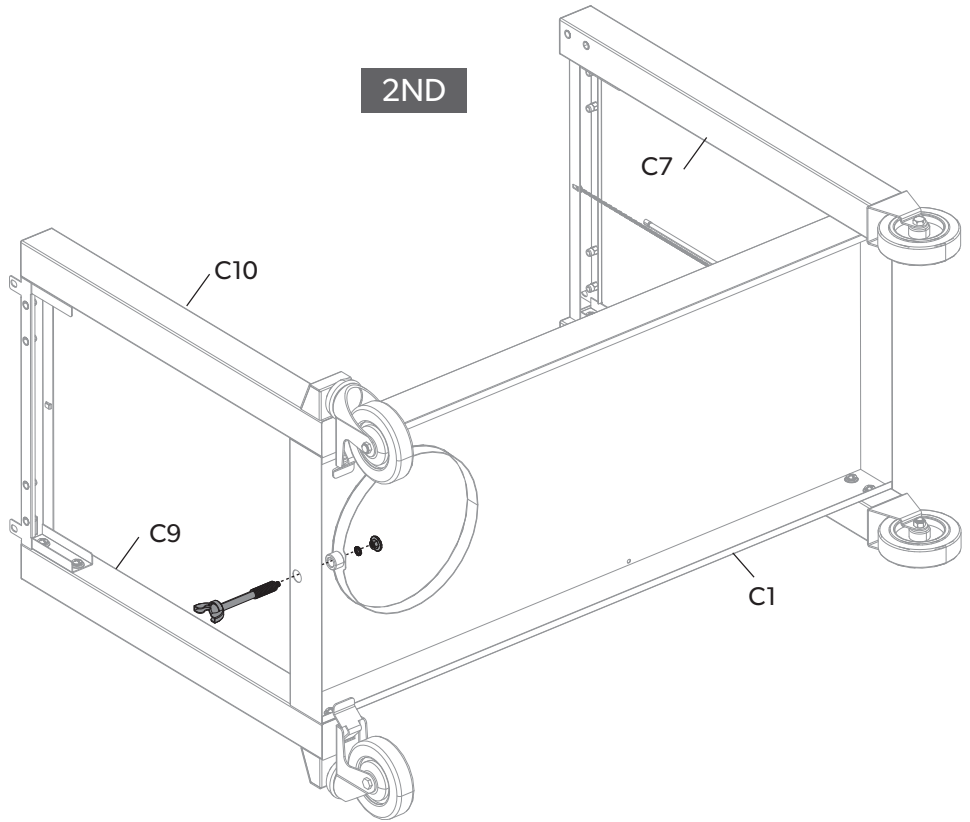

## 6

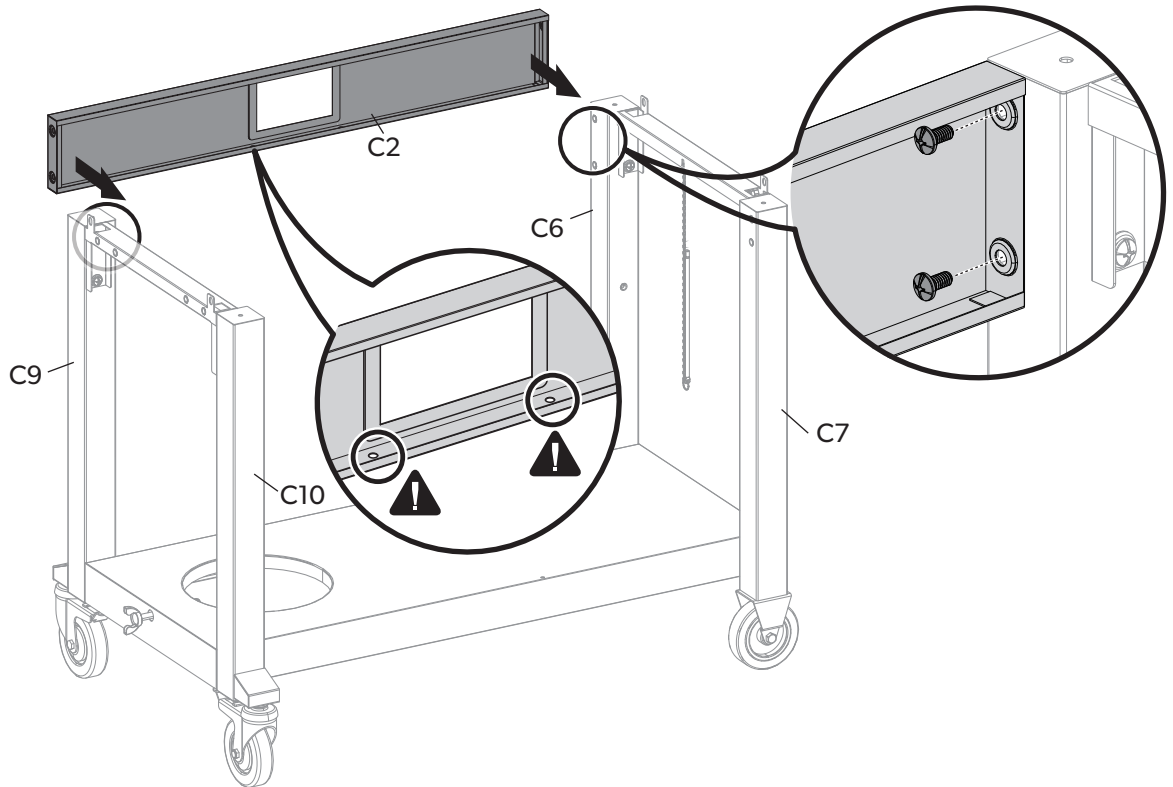
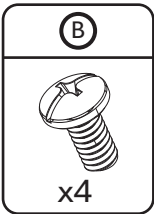

# ASSEMBLY INSTRUCTIONS

## 7

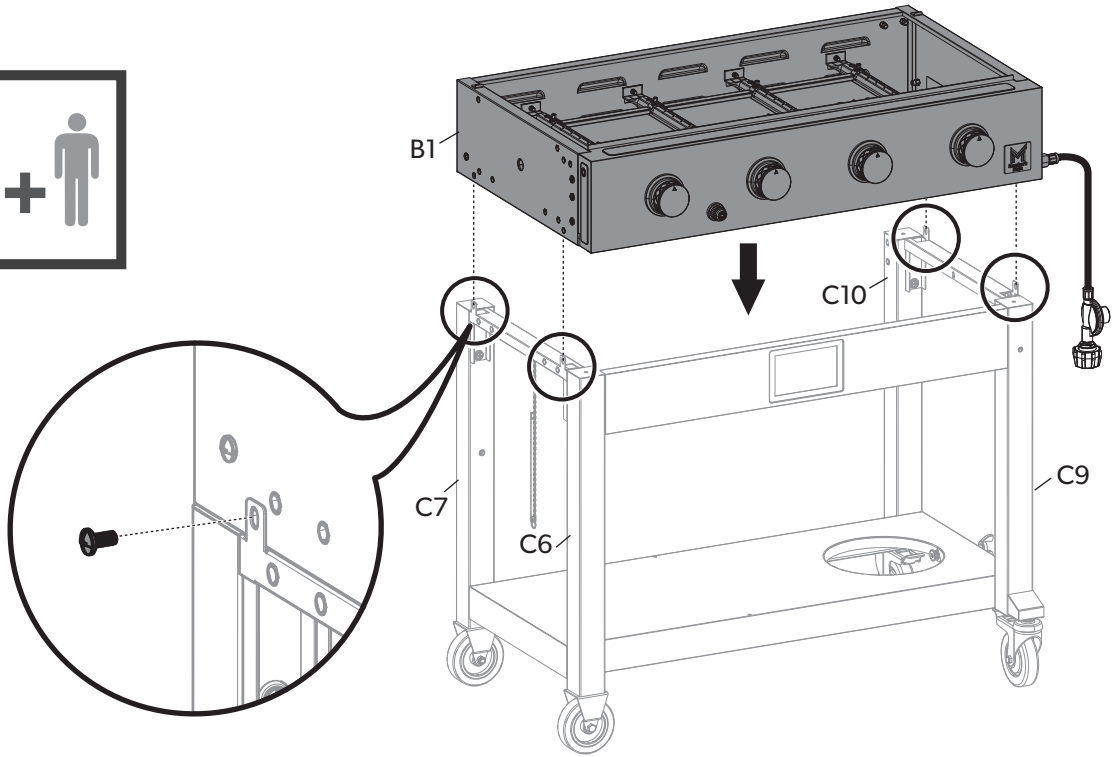
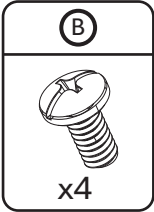

## 8

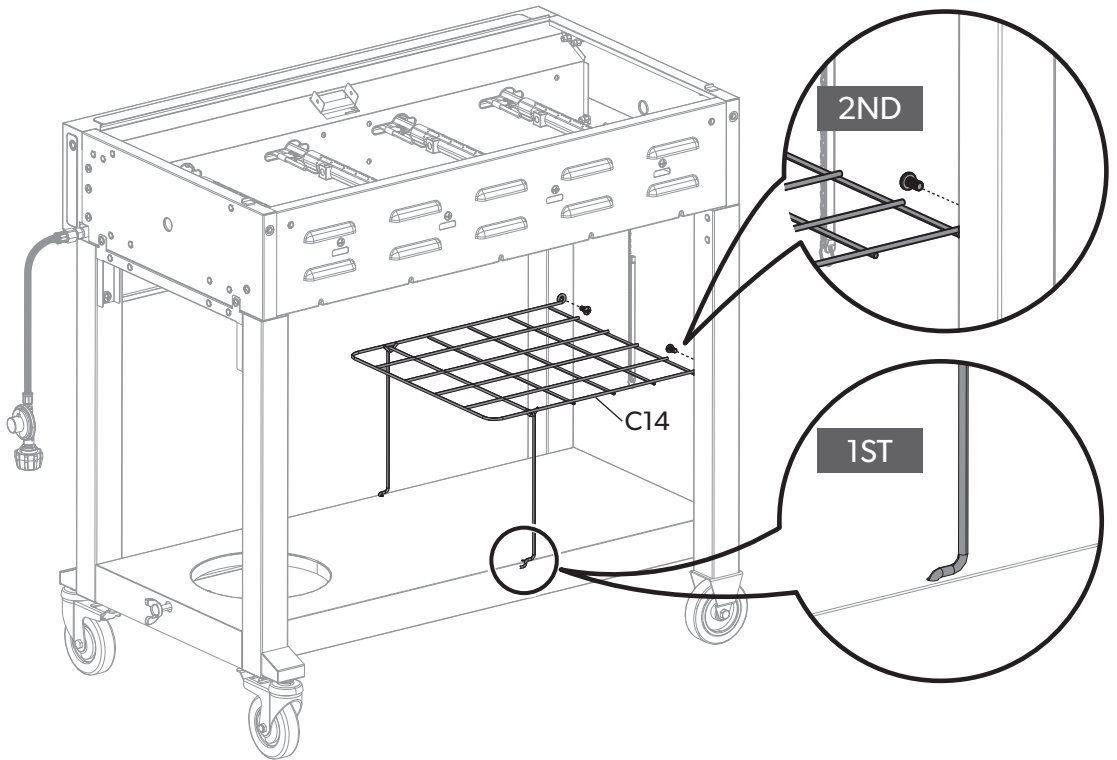
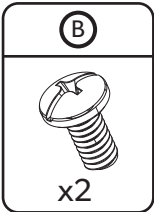

# ASSEMBLY INSTRUCTIONS

9

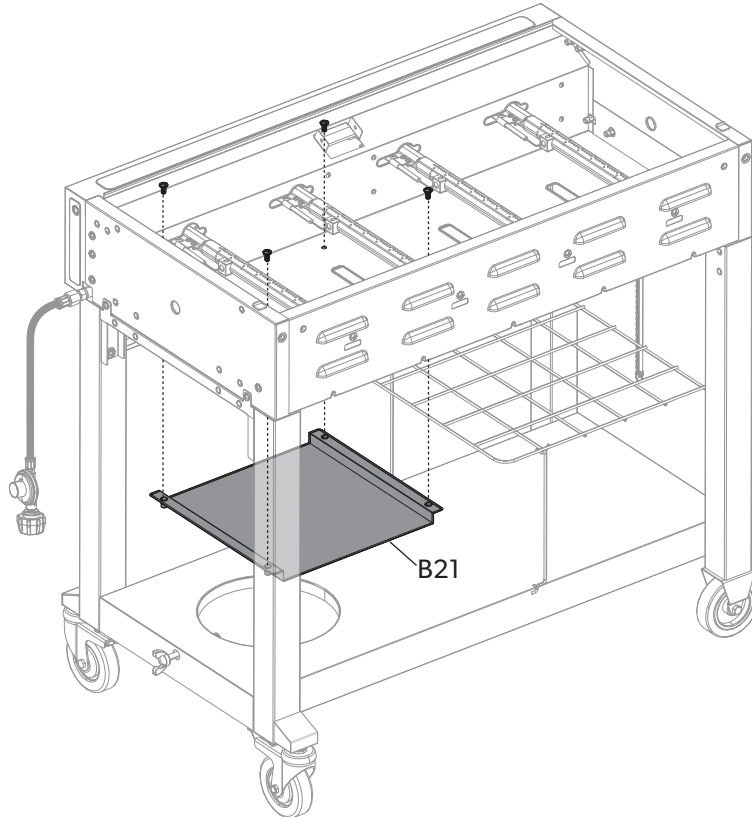
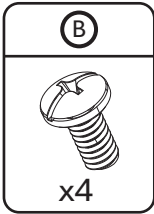

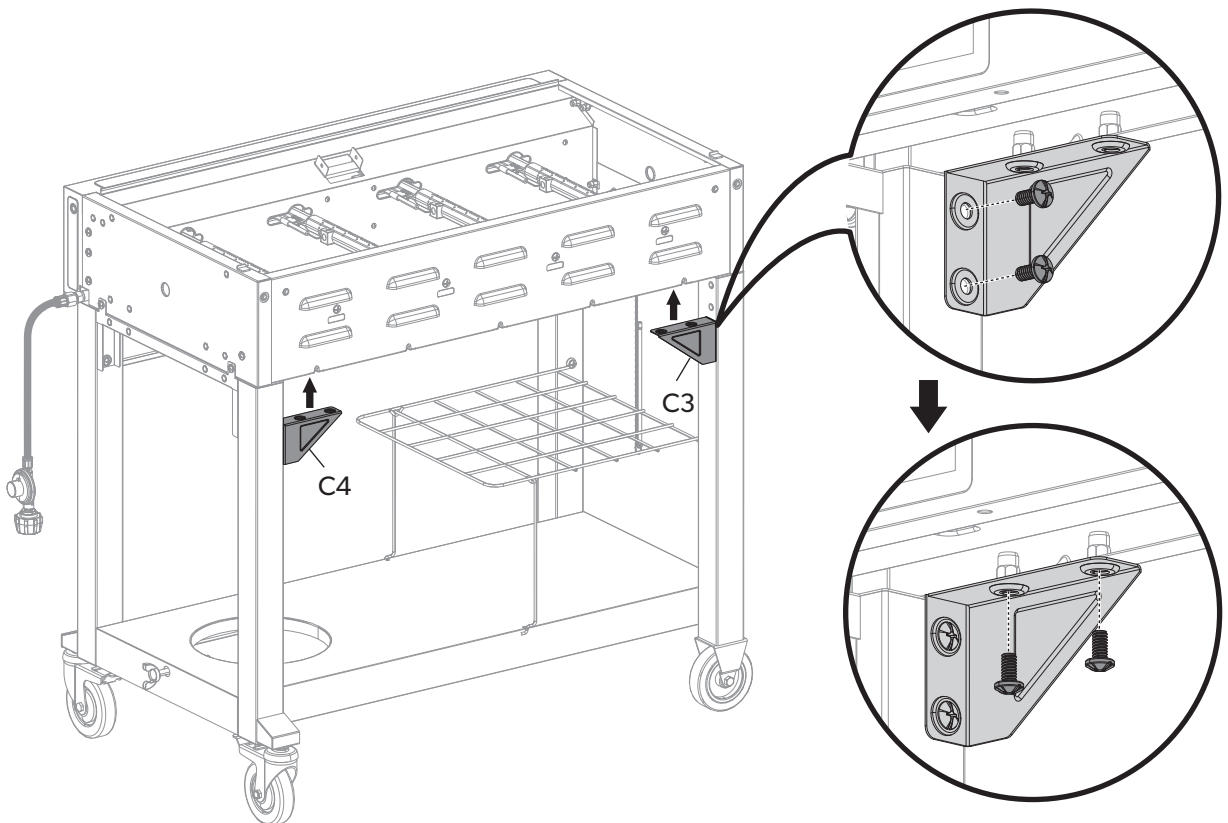
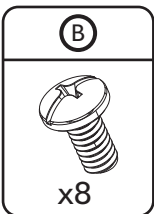

10



# ASSEMBLY INSTRUCTIONS

## 11

<b>(B)</b>	<b>(D)</b>
	
x2	x2

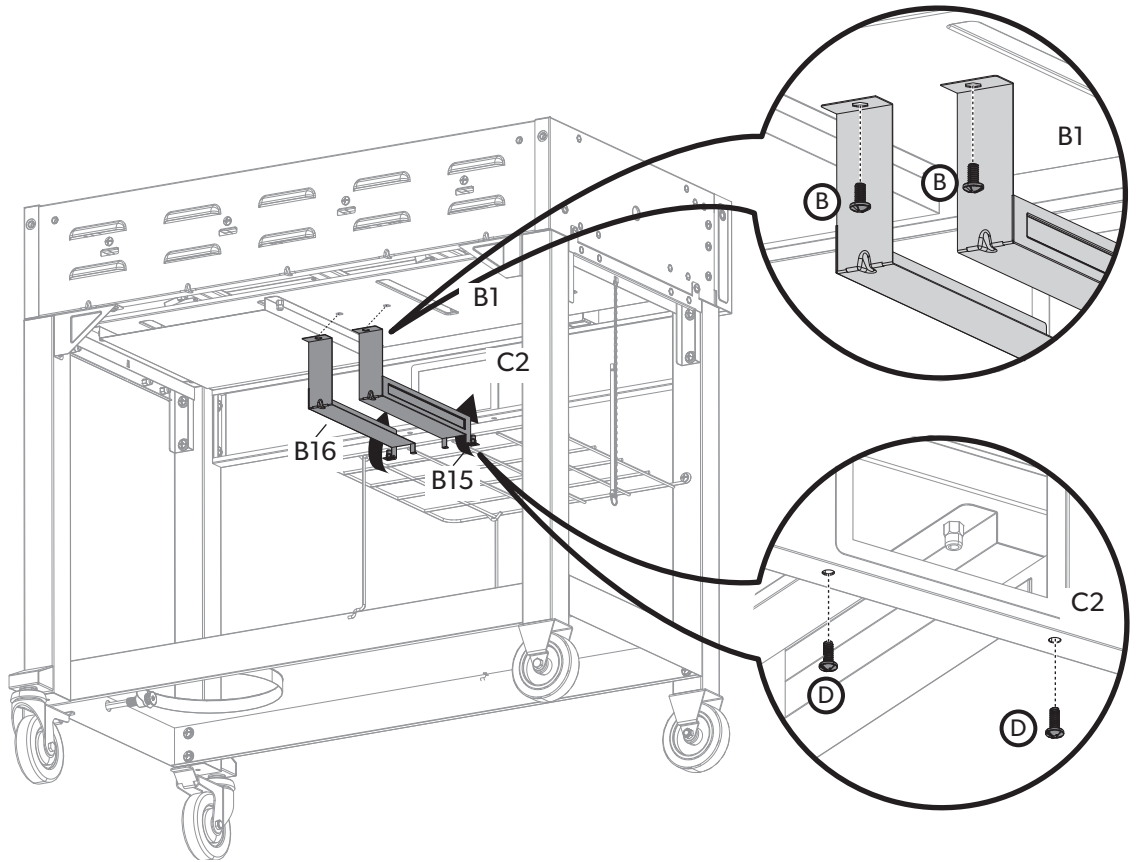

## 12

<b>(C)</b>

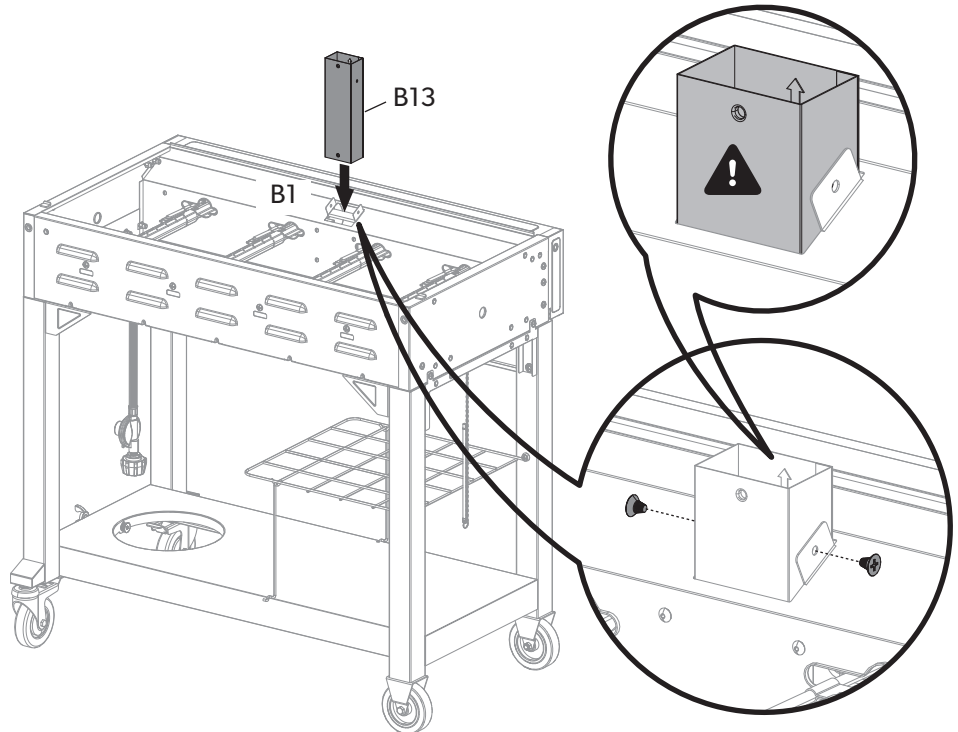
x2

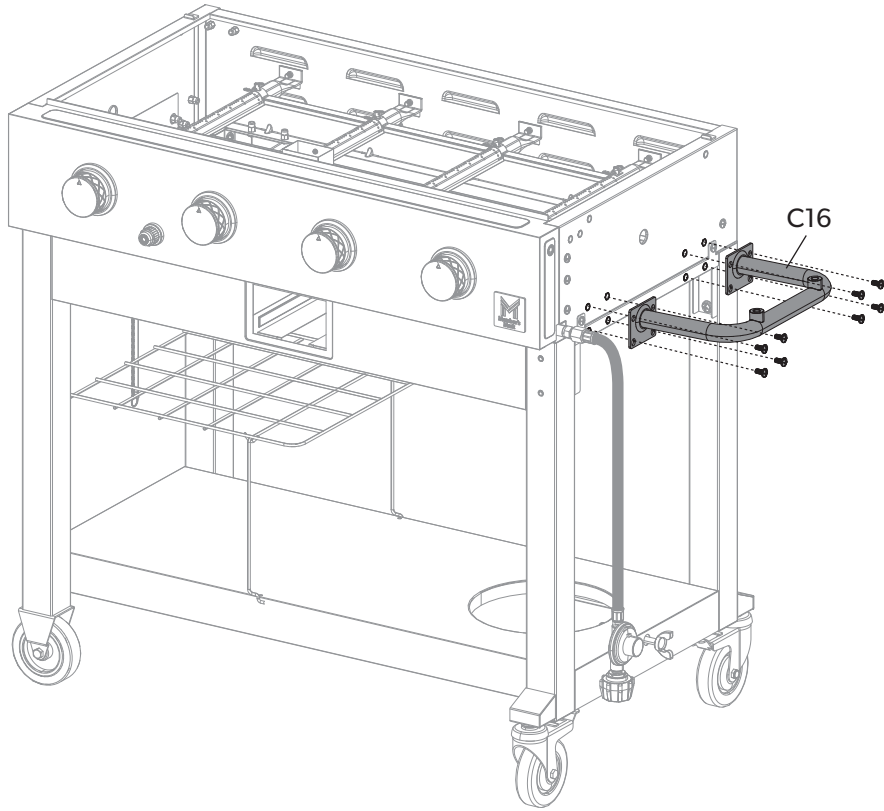
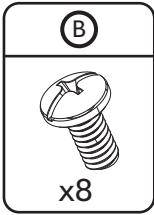

# ASSEMBLY INSTRUCTIONS

13



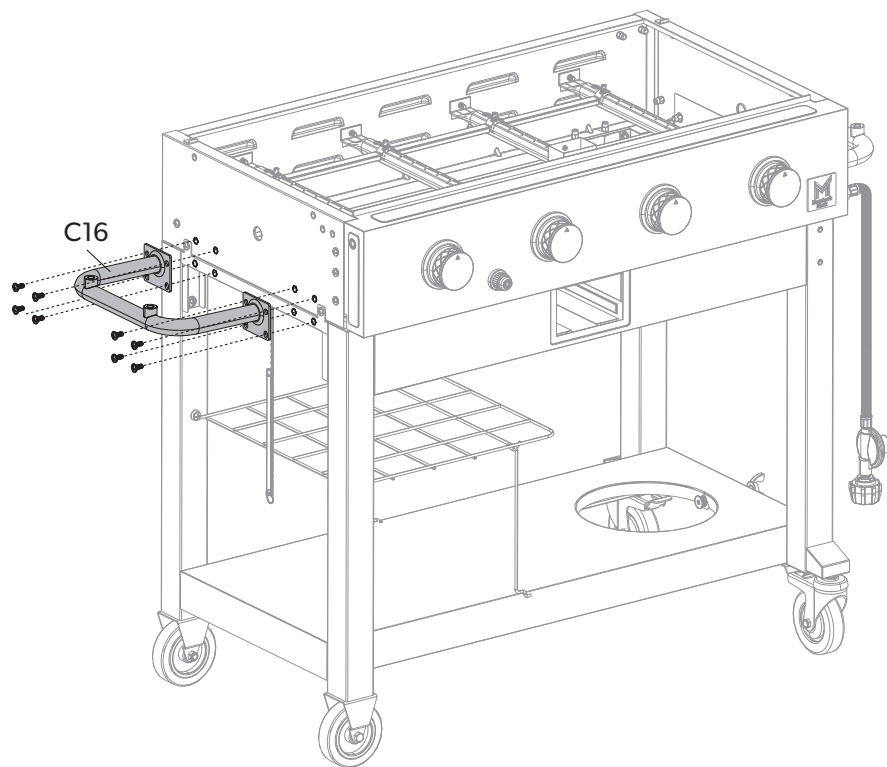
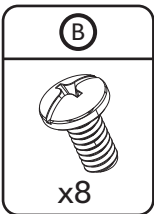

14

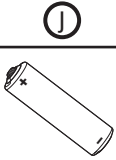

# ASSEMBLY INSTRUCTIONS

## 15

 x1	 x2
---	---

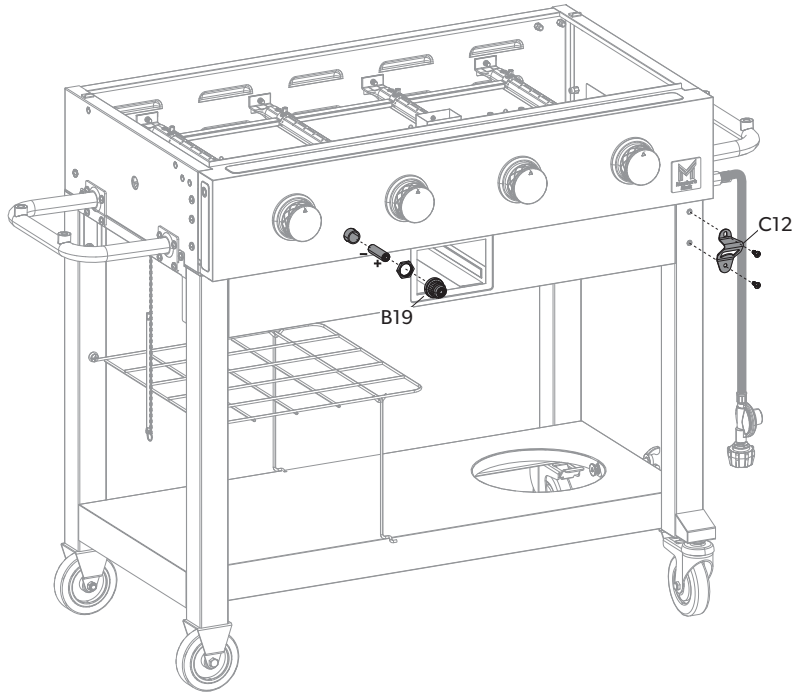

## 16

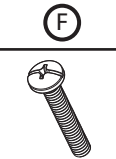

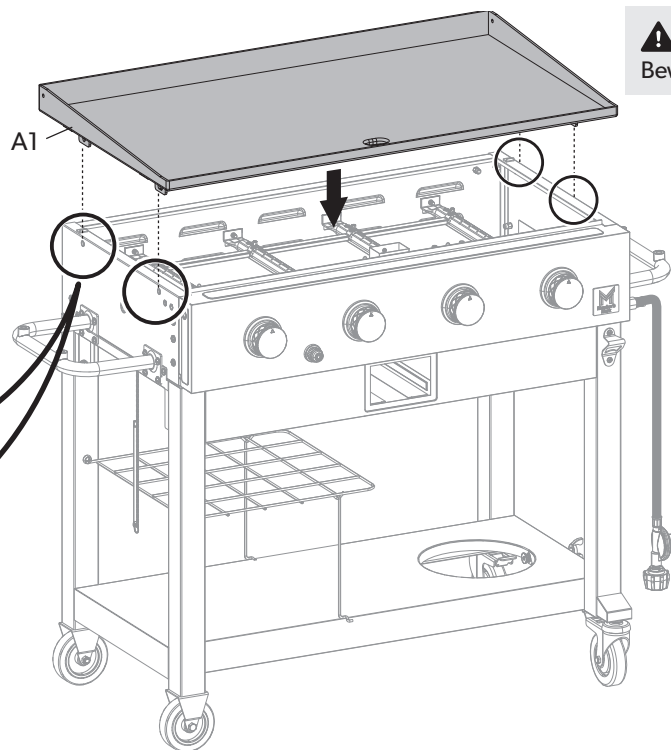
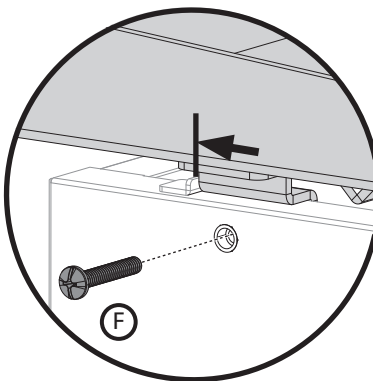
 x4
---



**⚠ WARNING**  
Beware of finger.



# ASSEMBLY INSTRUCTIONS

## 17

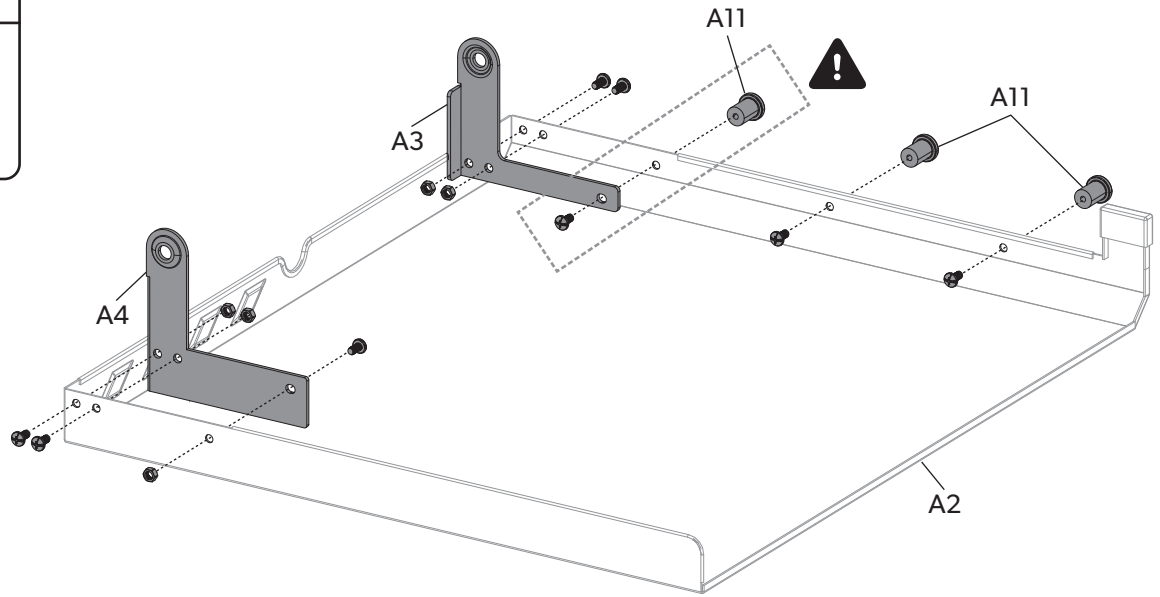
<b>D</b>	<b>E</b>
	
x8	x5



## 18

<b>D</b>	<b>E</b>
	
x8	x5

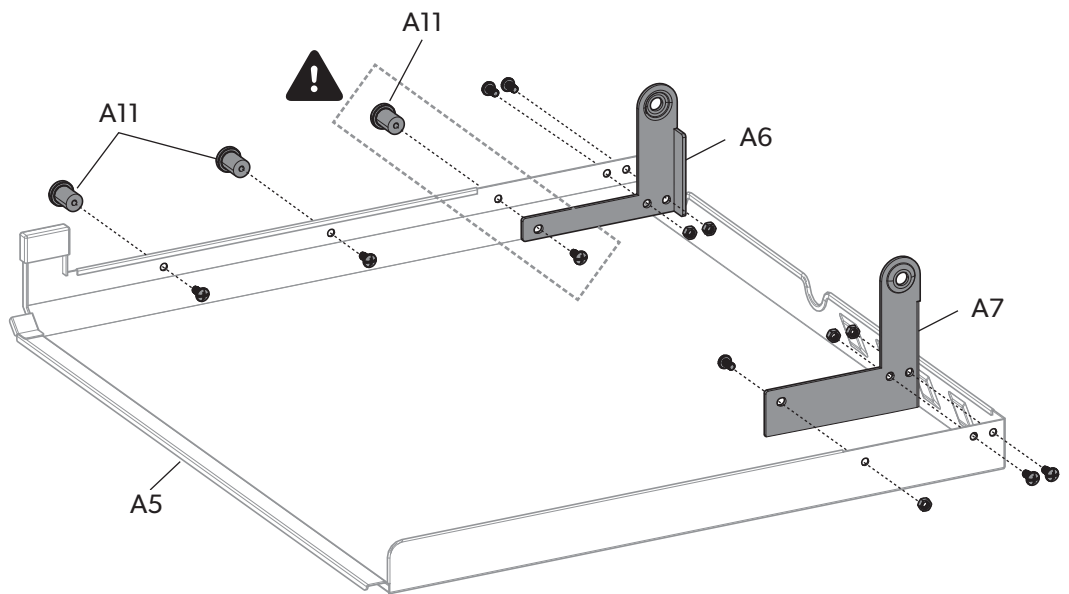

# ASSEMBLY INSTRUCTIONS

**19**

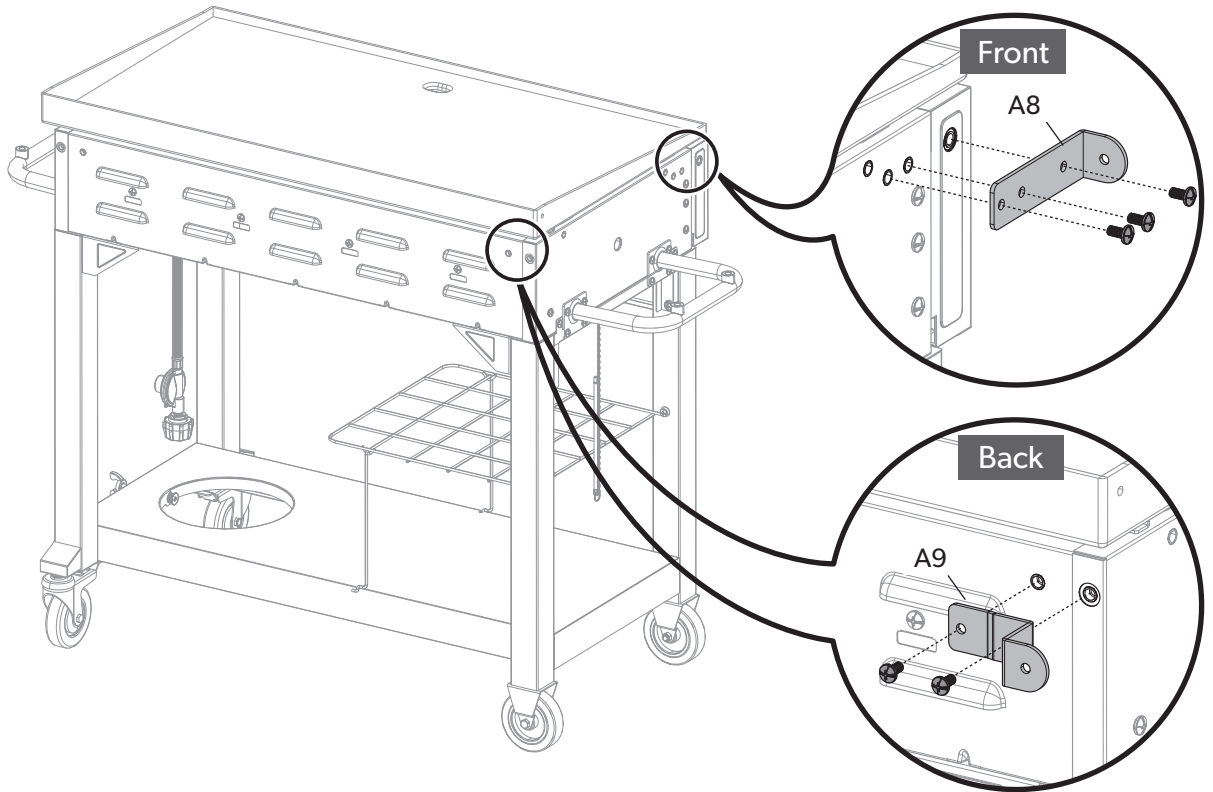
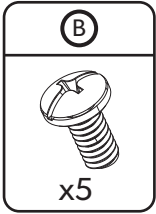



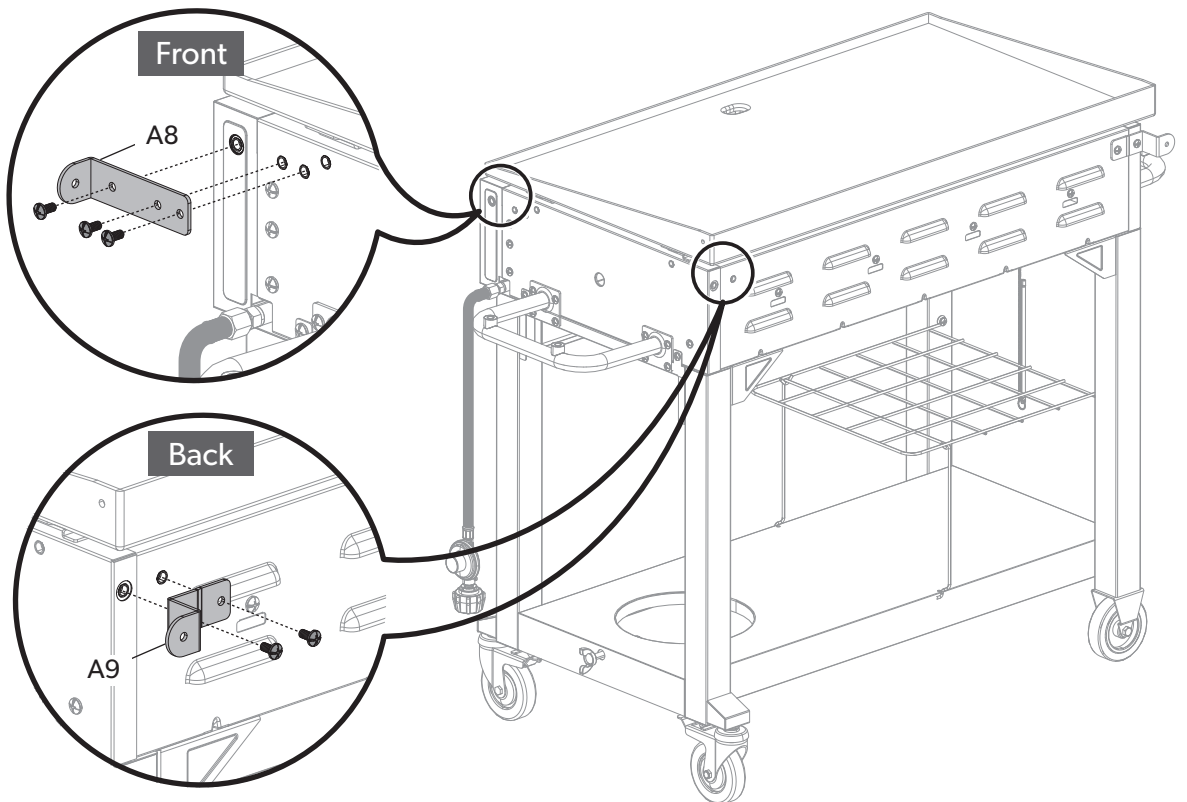
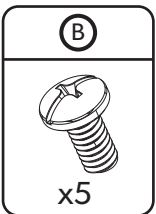



**20**



# ASSEMBLY INSTRUCTIONS

**21**

	
	
x4	x4

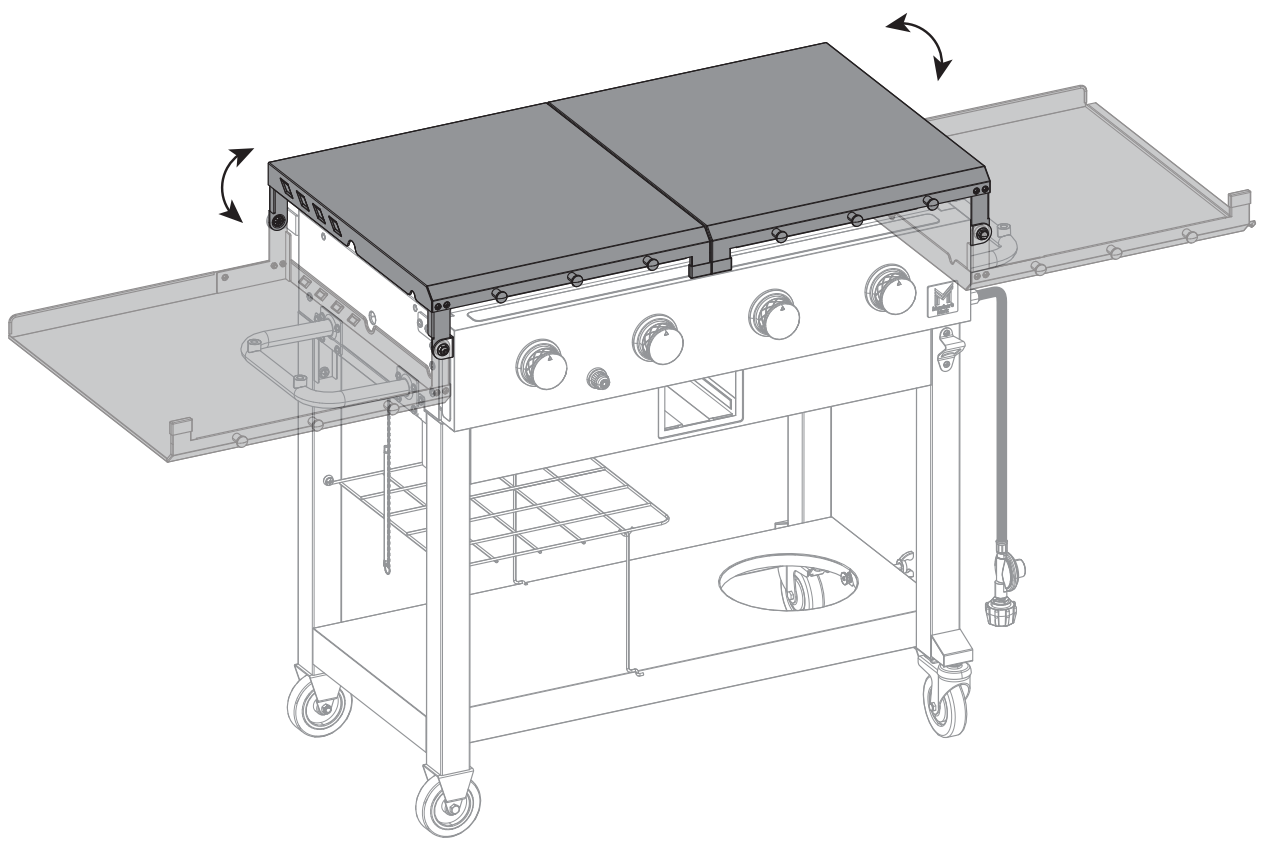
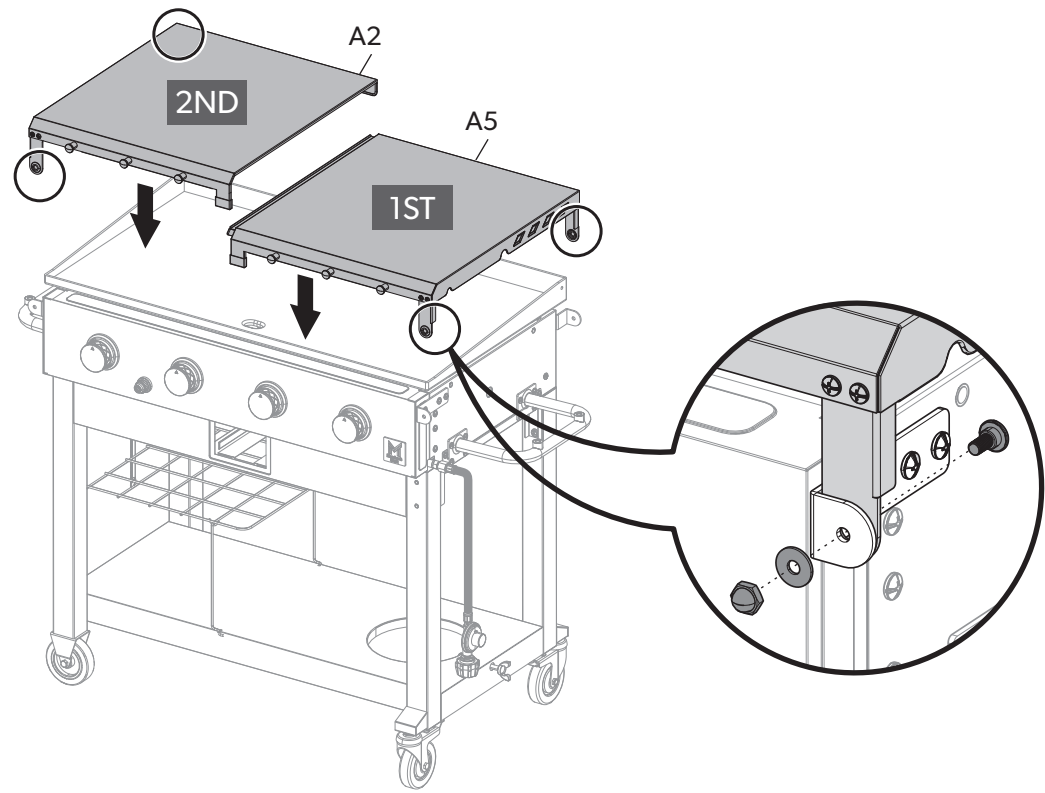

x4

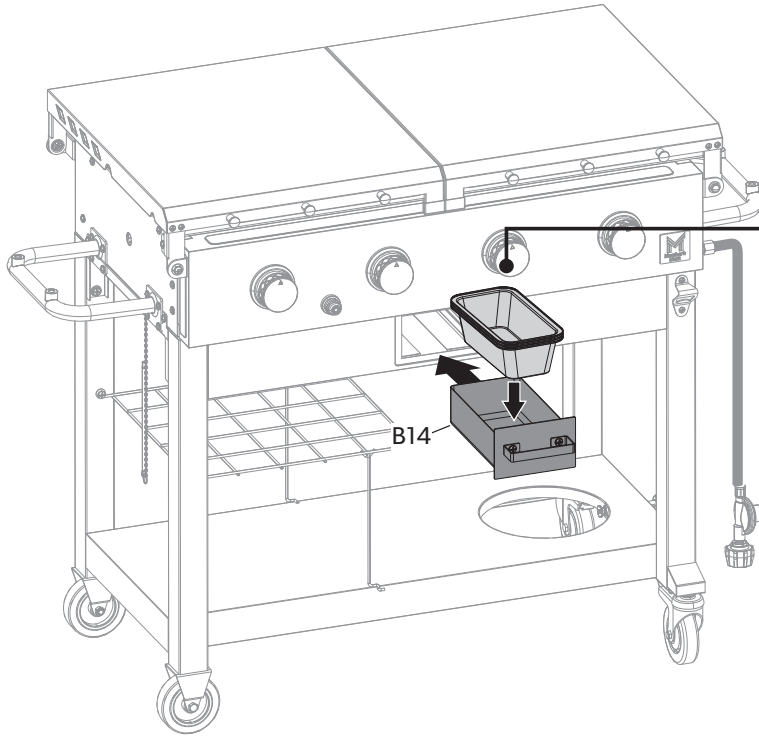

# ASSEMBLY INSTRUCTIONS

22



Call 1-833-454-0864 for customer support and to order replacements foil inserts (Item #G703-0607-C6).

4.5"  
8.6"  
2.6"

23

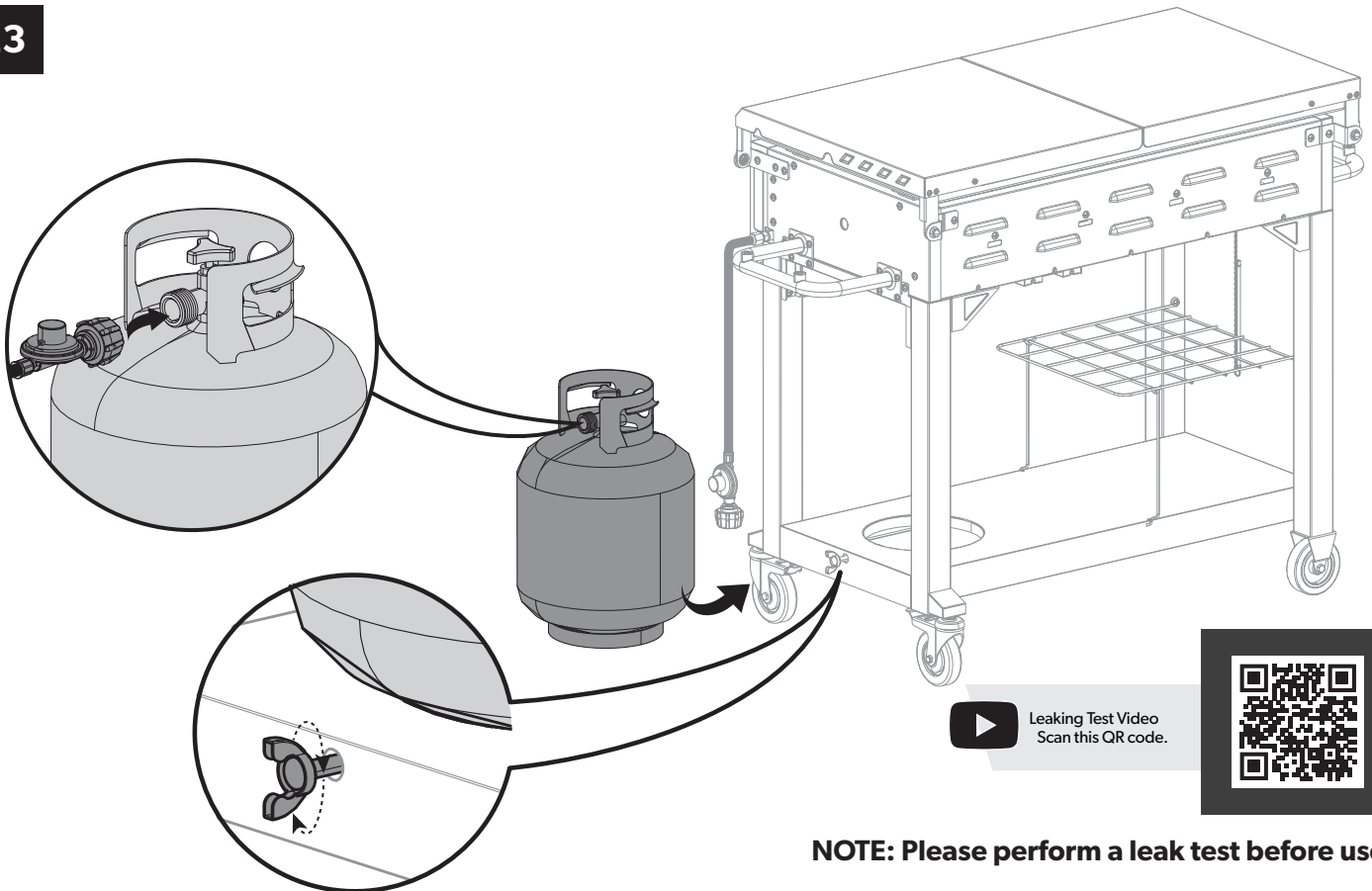

▶ Leaking Test Video  
Scan this QR code.

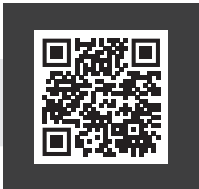

**NOTE: Please perform a leak test before use.**

## WARRANTY AND SERVICE

**This product is covered by the Sam's Club Member Satisfaction Guarantee.**

**Please visit [samsclub.com](https://www.samsclub.com) for more information.**

### **BEFORE YOU CALL FOR SERVICE, have the following information available:**

1. Serial Number: The serial number is located on the front of this manual and on the rating label located inside your grill cart.
2. Model Number: The model number is located on the front cover of this manual and on the rating label located inside your grill cart.
3. Proof Of Purchase: By the original owner.

**Call Customer Care Hotline: 1-833-454-0864**

### **IF YOUR PRODUCT IS DAMAGED:**

1. Call the Member's Mark Customer Care Hotline: 1-833-454-0864.
2. DO NOT return to the store for replacement of damaged or defective parts: Member's Mark Customer Care will ensure that all in-stock replacement parts arrive at your home within 3-10 business days.
3. Concealed Damage: If damage is unnoticed until merchandise is unpackaged, resolve issue by contacting Member's Mark Customer Care immediately.

### **LIMITED WARRANTY:**

Winners Products, hereby warrants to the Original Purchaser of this Member's Mark Pro-Series 5 Burner Gas Griddle that will be free of defects in workmanship, from the date of purchase, for the period of the warranty, as outlined below. Please see Limitations and Exclusions section on the following page.

Member's Mark warrants that components in your new Member's Mark Pro-Series 5 Burner Gas Griddle will be free of defects in material and workmanship from the date of purchase, for the following period:

Stainless Steel Burners.....5 years

All other components.....1 years

#### **⚠ CAUTION:**

Some parts may contain sharp edges – Especially as noted in the manual! Wear protective gloves if necessary. FOR RESIDENTIAL USE ONLY. DO NOT USE FOR COMMERCIAL COOKING.

#### **⚠ WARNING:**

Do not attempt to repair or alter the hose/valve/regulator for any assumed defect or for any type of retro fit or conversion. Any modifications to this assembly will void your warranty and create the risk of a gas leak and fire. Use only authorized replacement parts supplied by the manufacturer for your model.

## WARRANTY AND SERVICE

### LIMITATION AND EXCLUSIONS

#### **Winners Products has the following limitations to its warranty:**

1. This limited warranty is non-transferable and becomes void if used for commercial or rental purposes. Which includes (but not limited to): Restaurants, hotels, resorts, time shares or rental properties.
2. This warranty applies only when barbecue is used in the United States.
3. Warranty is in lieu of all warranties, expressed or implied, and all other obligations or liabilities related to the sale or use of its barbecue products.
4. Winners Products Engineering Ltd. Is not responsible for any misuse outside of the directions listed in the manual.
5. Winners Products Engineering Ltd. will repair or replace parts, at its option, proven defective under normal use and service and which on examination during the applicable warranty period. (See exclusions to warranty coverage below)
6. Shipping and handling charges are the responsibility of the original consumer-purchaser for all in/out of warranty part orders.
7. This limited warranty will not reimburse for the cost of any consequential losses, including (but not limited to) inconvenience, food, personal injury, expenses for travel, transportation or property damage.
8. Winners Products Engineering Ltd. does not authorize any person or company to assume for it any other obligation or liability in connection with the sale, installation, use, removal, return, or replacement of its equipment; and no such representations are binding on Winners Products Engineering Ltd.
9. The purchaser shall retain a copy of the purchase invoice for future claims.
10. Winners Products Engineering Ltd. does not provide warranty whatsoever in respect to accessories, or parts not supplied with original purchase.
11. Claims must be made within the duration of the period of coverage. Winners Products Engineering Ltd will not retroactively cover claims outside of the coverage period, even if the issue arose within the said period. It is the responsibility of the purchaser to establish warranty period with the date from the original sales receipt.
12. Winners Products Engineering Ltd. reserves the right to make changes or improvements to products it produces in the future without imposing on itself any obligations to install the same improvements in the products it has previously manufactured.

### EXCLUSIONS

#### **Winners Products Engineering Ltd. excludes from its warranty, the following:**

- a. Failure to perform regular maintenance, safety checks and service, including (but not limited to) removal of insects from venturi tubes, resulting in a flashback fire, damage caused by grease fires, flare-up fires or fires resulting from improper connection of hose to gas source.
- b. Part failure due to lack of cleaning, seasoning the griddle top and maintenance. Part failure due to use of improper cleaning products, such as indoor stainless-steel cleaners, abrasive and chemical cleaners, porcelain oven cleaner and other chemical cleaners which can cause damage to surfaces.
- c. Normal wear and tear, chipping and scratching on painted, porcelain enamel, stainless-steel or griddle surfaces. Dents, discoloration caused by environment or heat, surface corrosion, rust or rust perforation, chemical exposure in the atmosphere and other damages which result with normal use.
- d. Accidental damage, abuse, tampering or misuse, misapplication, vandalism, careless handling, modifications, neglect, improper assembly or installation, environmental such as severe weather conditions or situations otherwise uncontrollable by the manufacturer.
- e. Damages caused by failure to follow proper usage, safety and maintenance instructions presented throughout this manual.
- f. Warping griddle top: It is very common for griddles to expand and contract during heating and cooling, and in some cases with thermal shock the griddle can warp or pop-up temporarily, but will correct itself. This is likely to occur in the first couple months of use but will correct itself with continued use. You can reduce the impact by only placing room temperature foods on the griddle, never placing food right from the fridge or freezer onto the surface, and also not pouring water on the surface for cleaning.

**There are no other express warranties except as set forth herein and any applicable implied warranties of merchantability and fitness are limited in duration to the period of coverage of this express written limited warranty.**

**NOTE**

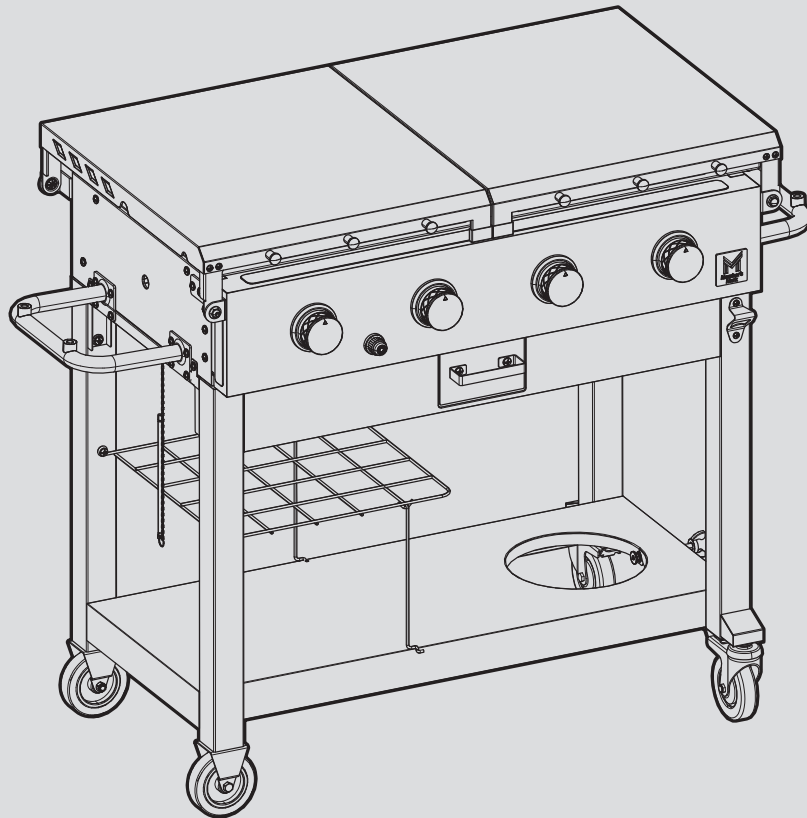

sam's club 

**Distributed by Sam's West Inc.**

2101 SE Simple Savings Dr. Bentonville,  
Arkansas 72716-0745

Made In China

**Winners Products Engineering Ltd**

27/F, Cofco Tower, 262 Gloucester Road,  
Causeway Bay, Hong Kong

**QUESTIONS OR COMMENTS?**

We would love to hear about your Member's  
Mark experience! Visit us at:  
[samsclub.com/membersmarkhelp](https://samsclub.com/membersmarkhelp)

[linktr.ee/member's.mark](https://linktr.ee/member's.mark)



CONTACT US: 1-833-454-0864