

**Rubbermaid**<sup>®</sup>

# FASTTRACK<sup>®</sup>



## 7Z02 – Locker Shelf Assembly Steps

2024640

Rubbermaid Incorporated,  
Huntersville, NC U.S.A. 28078-1801  
U.S.A. 1-888-895-2110  
Canada 1-866-595-0525  
[www.rubbermaid.com](http://www.rubbermaid.com)

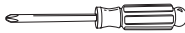
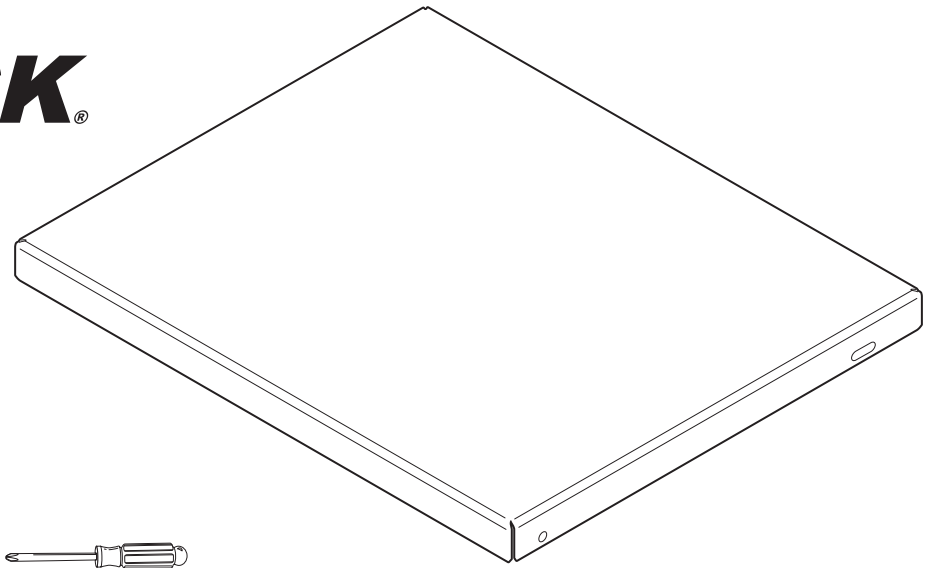
newell  
BRANDS

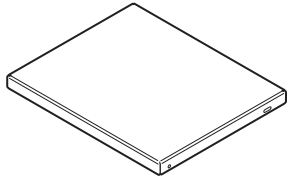

Pieces		Qty	Pieces		Qty
<b>A</b> Shelf		1	<b>B</b> Shelf Screws M5 x 8mm		4

### STEP 1

#### PICK A SHELF POSITION OPTION

NOTE: Lower Locker 7W96 features five mounting locations. Upper Locker 7W95 features three mounting locations.

Using the predetermined shelf positions, choose the location for the shelf inside of the locker.

1. Round Hole = Front
2. Slotted Hole = Back

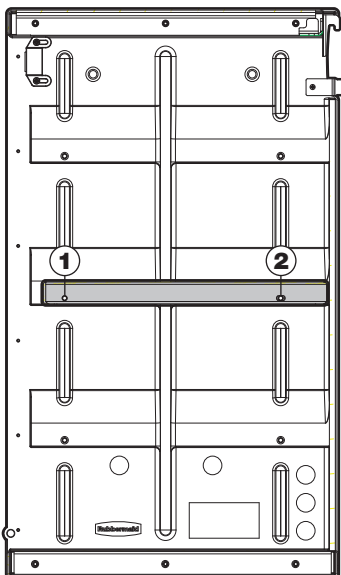

Lower Locker 7W96

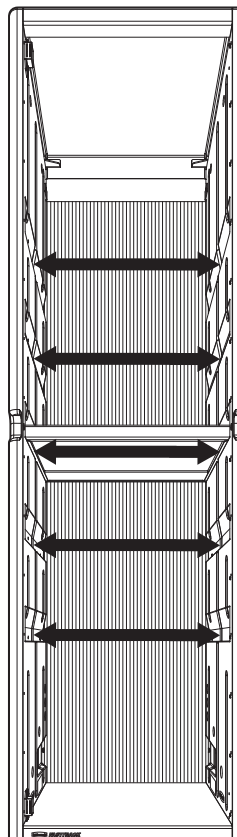

Upper Locker 7W95

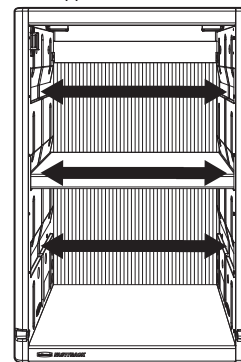

## STEP 2

### INSTALL SHELF

TIP: Use a magnetized tip screwdriver.

Position shelf (A) in any of the provided mounting positions.

NOTE: Slotted hole should be oriented towards the rear of the unit with the round hole oriented towards the front of the unit.

Attach shelf (A) by inserting four shelf screws (B) into the molded-in nut on the side panels.

1. Align and install front screws.
2. Align and install back screws.

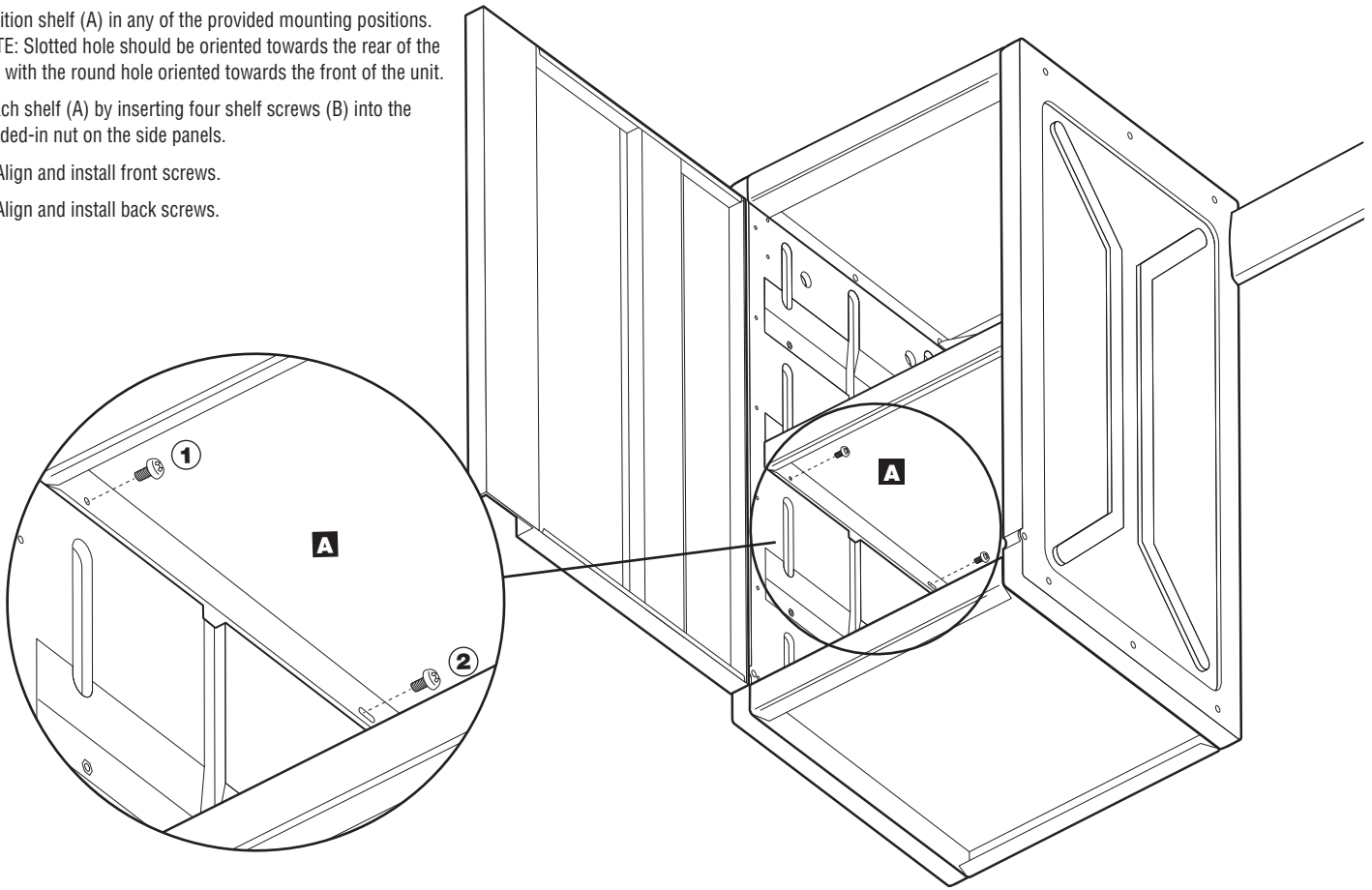

**Rubbermaid**®

# FASTTRACK®

## 7Z02 – Étapes d'assemblage de l'étagère de casier

2024640

Rubbermaid Incorporated,  
Huntersville, NC, États-Unis 28078 - 1801

U.S.A. 1-888-895-2110

Canada 1-866-595-0525

[www.rubbermaid.com](http://www.rubbermaid.com)

**newell**  
BRANDS

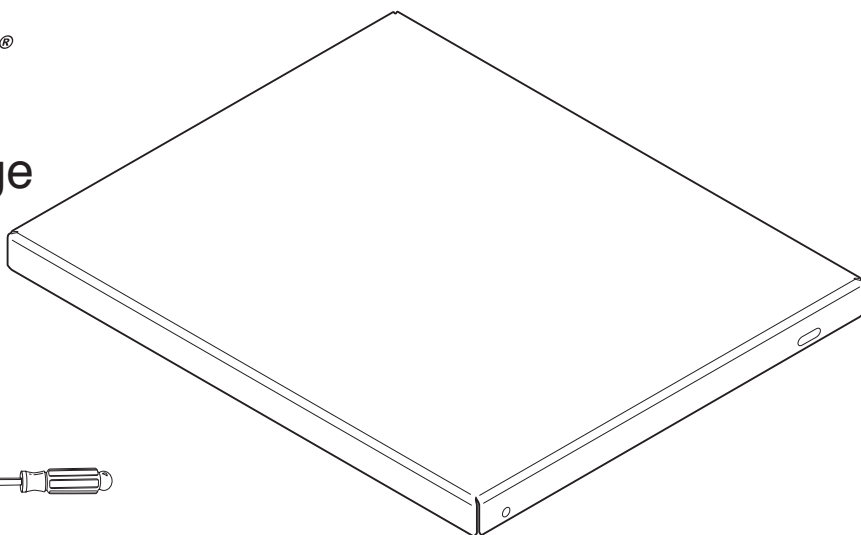

Pièces	Qté.	Pièces	Qté.
<b>A</b> Étagère	1	<b>B</b> Vis à étagère M5 x 8 mm	4

### ÉTAPE 1

#### CHOISISSEZ LA POSITION DE L'ÉTAGÈRE

REMARQUE : Le casier inférieur 7W96 comporte cinq emplacements de montage. Le casier supérieur 7W95 comporte trois emplacements de montage.

En utilisant les positions prédéterminées pour l'étagère, choisissez l'emplacement de l'étagère à l'intérieur de l'armoire.

1. Trou rond = avant
2. Trou oblong = arrière

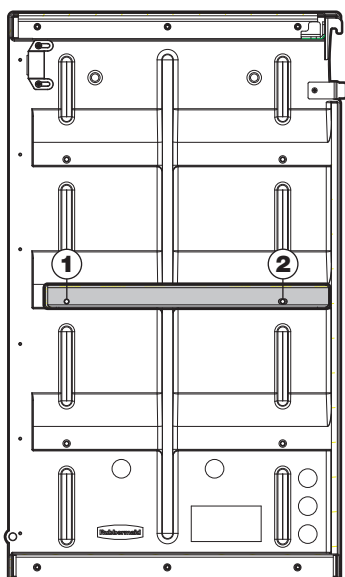

Casier inférieur 7W96

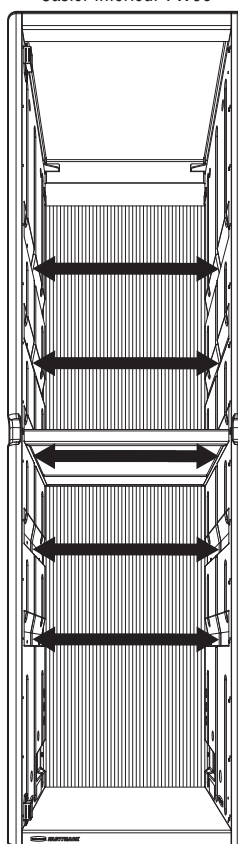

Casier supérieur 7W95

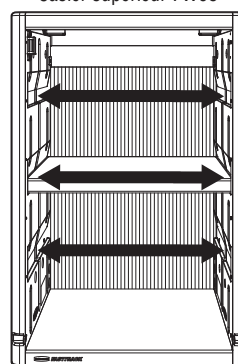

## INSTALLER L'ÉTAGÈRE

ASTUCE : Utilisez un tournevis à pointe magnétique.

Placez l'étagère (A) dans l'une des positions de montage fournies.

REMARQUE : Le trou oblong doit être orienté vers l'arrière de l'unité avec le trou rond orienté vers l'avant de l'unité.

Fixez l'étagère (A) en insérant quatre vis à étagère (B) dans l'écrou moulé sur le panneaux latéraux.

1. Alignez et installez les vis avant.
2. Alignez et installez les vis arrières.

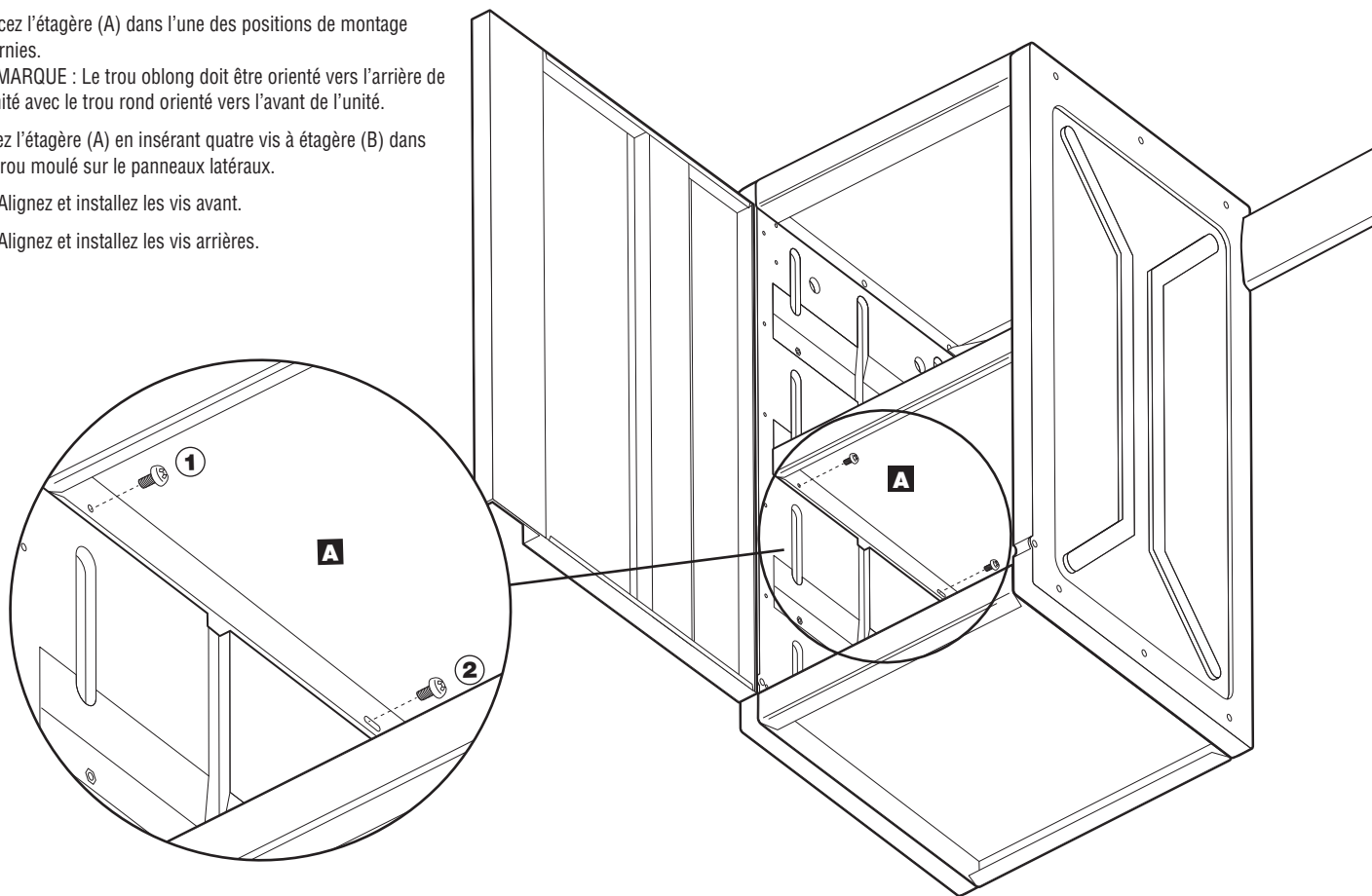

**Rubbermaid**®

# FASTTRACK®

## 7Z02 – Pasos para el armado del estante para armario

2024640

Rubbermaid Incorporated,  
Huntersville, NC U.S.A. 28078-1801  
Estados Unidos 1-888-895-2110  
Canadá 1-866-595-0525  
[www.rubbermaid.com](http://www.rubbermaid.com)

newell  
BRANDS

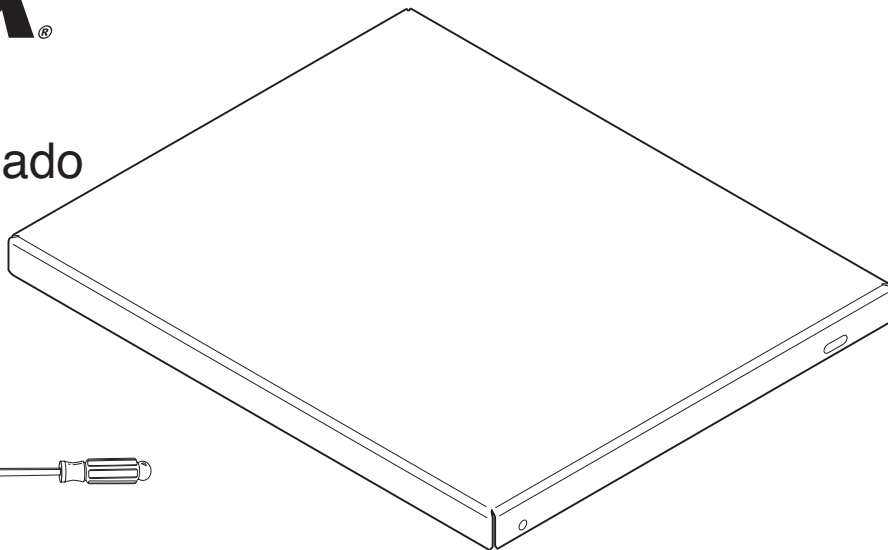
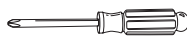

Piezas	Cantidad	Piezas	Cantidad
<b>A</b> Estante	1	<b>B</b> Tornillos para estantes M5 x 8mm	4

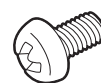

### PASO 1

#### ELEGIR UNA OPCIÓN PARA LA POSICIÓN DEL ESTANTE

NOTA: El armario inferior 7W96 ofrece cinco posiciones para el armado. El armario superior 7W95 ofrece tres posiciones para el armado.

Use las posiciones predeterminadas del estante y seleccione la ubicación para el estante dentro del armario.

1. Orificio redondo = Parte frontal
2. Orificio ranurado = Parte posterior

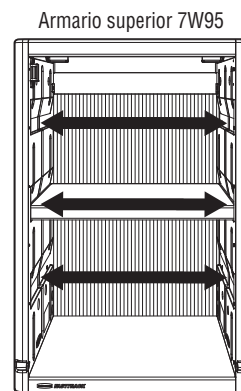
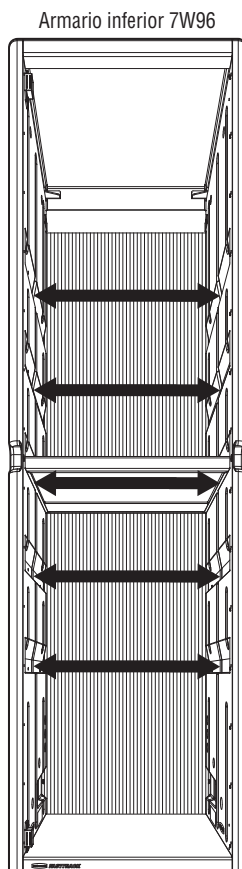
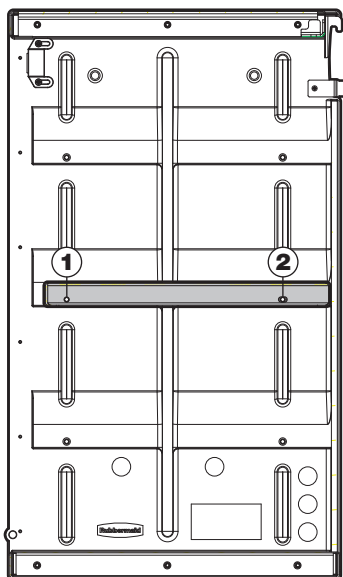

## INSTALAR ESTANTE

CONSEJO: Usar un destornillador de punta magnética.

Colocar el estante (A) en cualquiera de las posiciones de armado que se proporcionan.

NOTA: El orificio ranurado debe orientarse hacia la parte posterior de la unidad y el orificio redondo debe estar orientado hacia la parte frontal de la unidad.

Para fijar el estante (A), insertar cuatro tornillos para estantes (B) en las tuercas moldeadas de los paneles laterales.

1. Alinear y colocar los tornillos frontales.
2. Alinear y colocar los tornillos de la parte posterior.

