

Specifications provided by the Supplier in accordance with Spectrum's graphic procedures, modifications to any part of this mechanical is prohibited without the expressed authorization of the Spectrum Graphics Department.

Troubleshooting Guidelines

Symptom	Comments/Solution
<i>If your filter fails to pump water or flow has slowed...</i>	<ul style="list-style-type: none"> • Make certain the power outlet is functioning properly. Unplug electrical cord momentarily, then reconnect to power source to restart the Impeller. • Check to make sure Impeller Housing is firmly seated in Filter Box and that water is at correct level. • Remove Impeller Housing and make sure Impeller Assembly is free to rotate. A particle of carbon or gravel may be interfering. • Inspect aquarium water level. Maintain at 1/2 inch below top of frame. • Clean inside of Intake Tube with a flexible filter brush (not included).
<i>If your filter makes excessive mechanical noise...</i>	<ul style="list-style-type: none"> • Make sure Impeller Housing is firmly seated in Filter Box and water is at correct level. • Remove Impeller Housing and make sure Impeller Assembly is free to rotate. A particle of carbon or gravel may be interfering. • Replace worn Impeller. (Consult Replacement Parts List for correct part.)
<i>If your BIO-Wheel® splashes and/or makes excessive water noise. . .</i>	<ul style="list-style-type: none"> • Allow 24-48 hours for "breaking in" period. Material in a BIO-Wheel is not fully absorptive when new. • Check aquarium water level. Lower than recommended levels can result in excessive splash or noise.
<i>If your BIO-Wheel fails to move or stops...</i>	<ul style="list-style-type: none"> • Inspect the BIO-Wheel Bearings and Axle for dirt or mineral deposits. You may need to clean these areas carefully. • Make sure all parts are installed properly and that nothing is blocking the BIO-Wheel. • Examine the Intake Tube for flow interference. • Lift the Filter Cartridge and check for blockage. • Perform regular filter maintenance. • Check BIO-Wheel Bearings for wear as these wear through in time.
<i>If your BIO-Wheel becomes discolored or dirty...</i>	<ul style="list-style-type: none"> • This is not a problem. It indicates the growth of beneficial biological bacteria that remove toxic ammonia and nitrite from aquarium water. Do not attempt to clean BIO-Wheel pleats. • As long as a BIO-Wheel is not damaged, it does not need to be replaced.

TWO-YEAR LIMITED WARRANTY

Spectrum Brands Pet LLC (SBP) warrants this filter against defects in material or workmanship for two years from the date of original purchase, subject to the conditions and exceptions stated below.

Your sales receipt is your Proof-of-Date-of-Purchase.

If the filter exhibits such a defect, SBP will repair or replace it, our option, without cost for parts or labor. The filter must be shipped postage paid to SBP. Proof-of-Date-of-Purchase is required. You are responsible for proper shipping.

Call customer service at 1.800.322.1266 for return authorization and shipping address.

This warranty does not cover damage caused by accident, misuse, abuse or failure to follow the

instructions accompanying this filter. All implied warranties, including any implied warranty of merchantability or fitness for any purpose are limited to two years. Fish and plant loss, personal injury, property loss or damage (direct, incidental or consequential) resulting from the use of the filter are not covered by this warranty.

Because some states/provinces do not allow the exclusion or limitation of incidental or consequential damages, or allow limitations on how long an implied warranty lasts, the above limitations or exclusion may not apply to you. This warranty gives you specific legal rights. You may also have other rights which vary from state/province to state/province.

Limited warranty doesn't include maintenance parts such as cartridge, impeller or rubber parts.

Spare Parts

<i>Motor Assembly</i>	AQ-78188
<i>Tube Assembly</i>	AQ-78191
<i>Impeller Assembly</i>	AQ-78197
<i>BIO-Wheel Assembly</i>	AQ-78203
<i>Dampeners</i>	AQ-78204

Cartridge Size

	<i>Emperor Pro 450</i>
<i>Rite-Size™ E</i>	X

*See Parts Check section for images of parts: **Motor Assembly:** Parts 3 & 4 **Tube Assembly:** Parts 9, 10, 11, 12 & 13
Impeller Assembly: Part 6 **BIO-Wheel Assembly:** Part 16 **Dampener:** Part 8



Questions or Missing Parts?

Call Customer Service at
 1-800-322-1266
 Monday - Friday 8:00 AM to 5:30 PM ET
 17-30434

MANUFACTURED FOR SPECTRUM BRANDS PET LLC
 3001 COMMERCE ST.
 BLACKSBURG, VA 24060
 1-800-322-1266 • www.marineland.com
 ©/TM/© 2019 SPECTRUM BRANDS, INC.
 OR ONE OF ITS AFFILIATES
 MADE IN CHINA



Emperor[®] Pro Power Filter 450



- For best results, use gravel instead of sand in your aquarium
- For best fit, standoff can be removed:
 - The filter was designed to securely fit a variety of frame sizes up to 1.16" thick
- The lid is hinged at the back but can also be removed by pulling straight up

IMPORTANT SAFETY INSTRUCTIONS

WARNING: To guard against injury, basic safety precautions should be observed, including the following:

READ AND FOLLOW ALL SAFETY INSTRUCTIONS

DANGER: To avoid possible electric shock, special care should be taken since water is employed in the use of aquarium equipment. For each of the following situations, do not attempt repairs by yourself; return the appliance to an authorized service facility for service or discard the appliance:

1. If the appliance shows any sign of abnormal water leakage, immediately unplug it from the power source.
2. Carefully examine the appliance after installation. It should not be plugged in if there is water on parts not intended to get wet.
3. **DO NOT** operate any appliance if it has a damaged cord or plug, or if it is malfunctioning or has been dropped or damaged in any manner.
4. To avoid the possibility of the appliance plug or receptacle getting wet, position aquarium stand and tank to one side of a wall-mounted receptacle to prevent water from dripping onto the receptacle or plug. A "drip loop," shown in the figure at right, should be arranged by the user for each cord connecting an aquarium appliance to a receptacle.
The drip loop is that part of the cord below the level of the receptacle, or the connector if an extension cord is used, to prevent water traveling along the cord and coming in contact with the receptacle.

If the plug or receptacle does get wet, **DO NOT** unplug the cord. Disconnect the fuse or circuit breaker that supplies power to the appliance, then unplug and examine for presence of water in the receptacle.
5. Close supervision is necessary when any appliance is used by or near children.
6. To avoid injury, **DO NOT** contact moving parts or hot parts such as heaters, reflectors, lamp bulbs and the like.
7. **ALWAYS** unplug an appliance from an outlet when not in use, before putting on or taking off parts and before cleaning.
NEVER yank cord to pull plug from outlet. Grasp the plug and pull to disconnect.
8. **DO NOT** use an appliance for other than intended use. The use of attachments not recommended or sold by the appliance manufacturer may cause an unsafe condition.
9. **DO NOT** install or store the appliance where it will be exposed to the weather or to temperatures below freezing.
10. Make sure an appliance mounted on a tank is securely installed before operating it.
11. Read and observe all the important notices on the appliance.
12. If an extension cord is necessary, a cord with a proper rating should be used. A cord rated for less amperes or watts than the appliance rating may overheat. Care should be taken to arrange the cord so that it will not be tripped over or pulled.

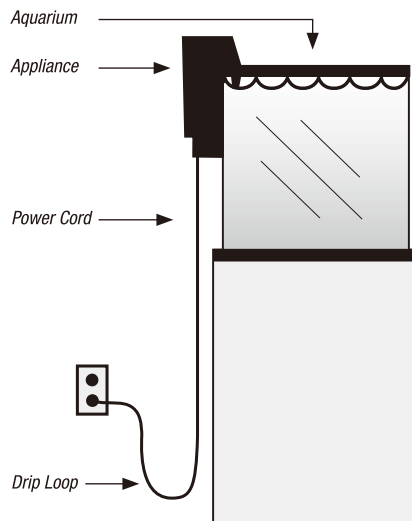

SAVE THESE INSTRUCTIONS

Assembly

- 1 Open Filter Lid** and remove any tube parts or packaging.
- 2 Rinse the cartridge** in clean, room temperature water that has been treated with a water conditioner to remove chlorine (this will extend the life of your carbon). Ensure the cartridge and BIO-Wheel® are secured in their place (Fig. 1).
- 3 Assemble tube parts** so that the strainer sits approximately 1 to 2 inches above your gravel (this may require you to either include or leave out the extension tube) (Fig. 2). If desired, open the mid-level intake by sliding the intake shaft down (Fig. 3).
- 4 Place filter** in back of your aquarium but do not plug in yet. Ensure your water level is at or above the minimum water level engraved on the Filter Motor (Fig. 3).
- 5 Plug in the filter**, making a drip loop for safety (see Safety Instructions).

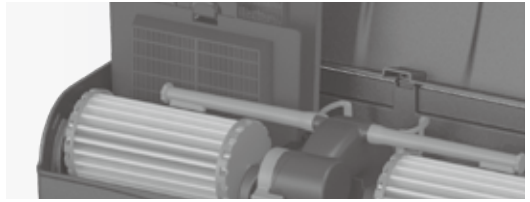

Fig. 1

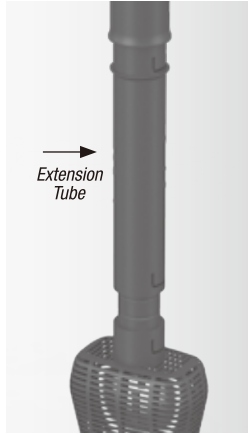

Fig. 2

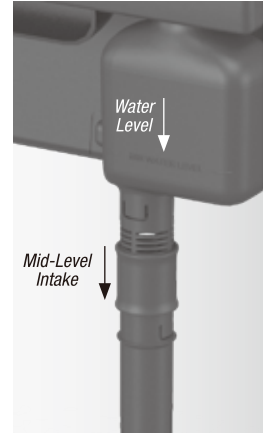

Fig. 3

Selecting Flow Rates

To select maximum flow, turn the flow control dial toward the front of the filter (toward the word "LOW") (Fig. 4).

To lessen flow, rotate the flow control dial toward the back of the filter (toward the word "HIGH") (Fig. 5).

Lowest flow rate: Flow control knob set to lowest setting produces the following flow rate:

Emperor® Pro 450: 110 GPH

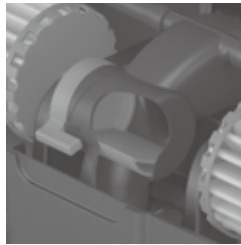

Fig. 4

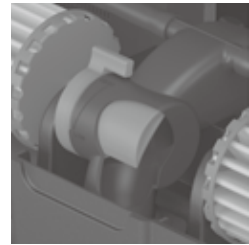
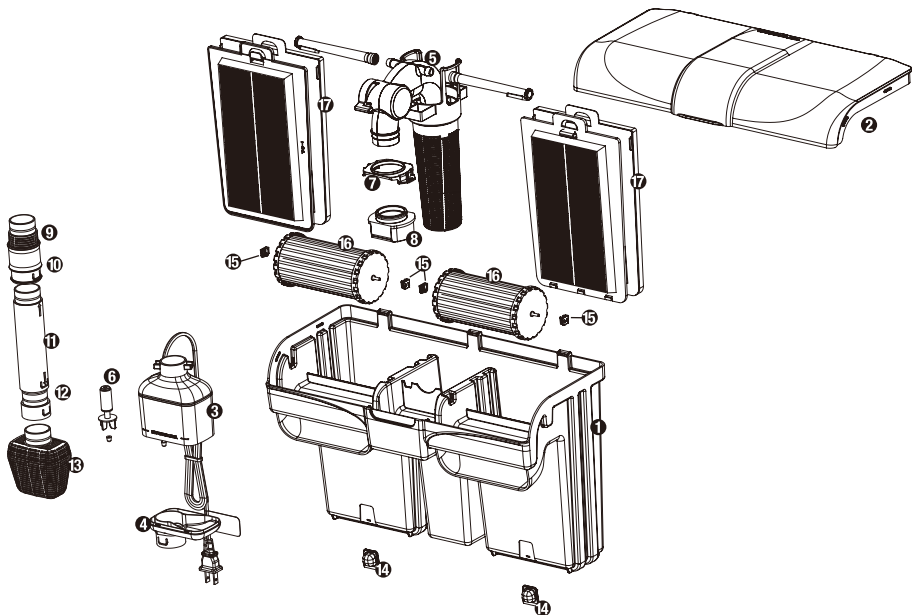

Fig. 5

Parts Check



- 1) Filter Housing 2) Filter Cover 3) Motor 4) Volute 5) Transfer Tube 6) Impeller 7) Motor Dampener Lock
 8) Motor Dampener 9) Intake Tube 10) Mid-Level Intake 11) Extension Tube 12) Intake Tube 13) Strainer
 14) Standoff 15) BIO-Wheel® Bearing 16) BIO-Wheel 17) Screen Cartridge

Filling The Media Basket

To access the media basket, first open the filter lid. Unhook the Intake Tube Tab from the Intake Tube. Gently lift the Intake Tube from the filter body. Lift the media basket from the filter body and fill as desired up to the fill line marked on the outside of the media basket or as recommended below:

Black Diamond® Carbon:

Place Marineland Black Diamond Carbon into a fine mesh bag up to the fill line for additional chemical filtration. Replace monthly, as carbon deactivates with use.

Diamond Blend® Zeolite:

- Test ammonia in parts per million ammonia x 0.009 = # of cups of zeolite/gal
- Test water frequently, replacing zeolite as needed until ammonia is removed
- Replace monthly or as needed
- Aquariums with very high ammonia levels may need zeolite replaced more often until ammonia issues are resolved
- Remove zeolite once ammonia levels drop

K2 Biological Media:

Add K2 media to media basket about an inch lower than the fill line to ensure the media has enough space to churn. Rinse in water treated with dechlorinator if needed.

Ceramic Rings:

Add ceramic rings to the media basket up to the fill line. Replace every three to four months or more often if needed.

The media basket can be removed to accommodate a micron filter.

Simply follow the directions for removing the media basket above and the micron filter in its place. Follow instructions with your micron filter for flow rate suggestions.

Impeller Removal

TO ACCESS IMPELLER FOR CLEANING AND REPLACEMENT:

- 1 Unplug filter** and lift out of the water.
- 2 Remove Strainer and Extension Tube** by pulling down from Impeller Cover as shown (Fig. 6).
- 3 Remove Impeller Cover** with a screwdriver using the slot provided (Fig. 7).
- 4 Remove the rubber impeller endcap** by pulling off impeller shaft (Fig. 8).
- 5 Pull Impeller Assembly** out and away from shaft. (**NOTE:** The magnet on the impeller may require some force to remove it from the shaft.) (Fig. 9).
- 6 Examine all parts** for debris that could cause blockage. Remove debris from Strainer, Extension Tubes and Impeller Cover by rinsing under cool water. Remove any material that may have twisted around the Impeller Shaft with a needle or tweezers. Rinse and clean Impeller Assembly by rinsing under cool water.
- 7 Reassemble** system and place on aquarium (Fig. 10).

NOTE: Do not operate filter without impeller.

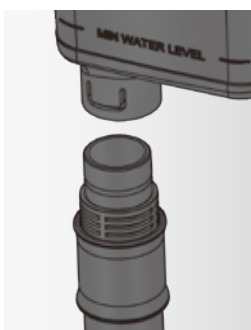

Fig. 6

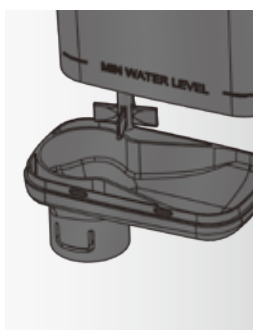

Fig. 7

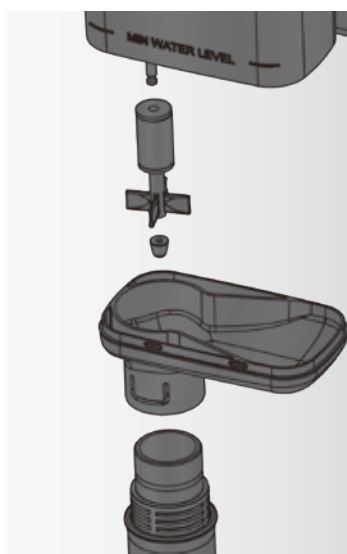

Fig. 10



Fig. 9



Fig. 8