

Kwikset



Powerbolt[®] 250

KEYPAD ELECTRONIC LOCK



Simple, Secure and Convenient Keyless Entry

- **KEYLESS ENTRY:** Makes coming and going secure and convenient.
- **EASY CODE MANAGEMENT:** 25 user codes and 5 one-time user codes.
- **AUTO LOCK:** Peace of mind with customizable, automatic locking.
- **INTRUSION ALERT:** 3 wrong codes disable keypad and sound alarm.
- **EASY LOW LIGHT CODE ENTRY:** Bright LED light up keypad.

#1 SELLING U.S. LOCK BRAND*

*Source: TraQline US quarterly brand unit share report, Q4 2006 through Q2 2023

Specifications

Battery	6V, 4 x AA alkaline batteries, 12-month battery life (batteries not included)
Door Prep	1 1/2" (38mm) or 2 1/8" (54mm) diameter cross bore hole and 1" diameter edge bore hole
Backset	Adjustable 2 3/8" (60mm) or 2 3/4" (70mm)
Door Thickness	1 3/8" (35mm) to 1 3/4" (44mm) standard. Thick door service part available for 2-1/4" (57mm) thick doors.
Faceplates	1" (25 mm) x 2 1/4" (57 mm) round corner faceplate with drive-in collar standard
Strikes	2 3/4" (70mm) x 1 1/8" (29mm) round corner 2-hole strike
Bolt	1" (25mm) throw, steel bolt
Door Handing	Reversible for right or left-hand doors
Cylinder	SmartKey Security™ KW1 cylinder
Security	Deadbolt: A156.36 Grade 3 Certified
Temperature Range	Exterior: -40F to 150F, Interior: 32F to 130F
Humidity	Exterior: 100% condensing, Interior: 30% to 95% non-condensing
Warranty	Lifetime Limited Mechanical and Finish Warranty; One Year Limited Electronics Warranty
Codes	Up to 25 user codes and 5 one-time user codes with optional programming code

Dimensions

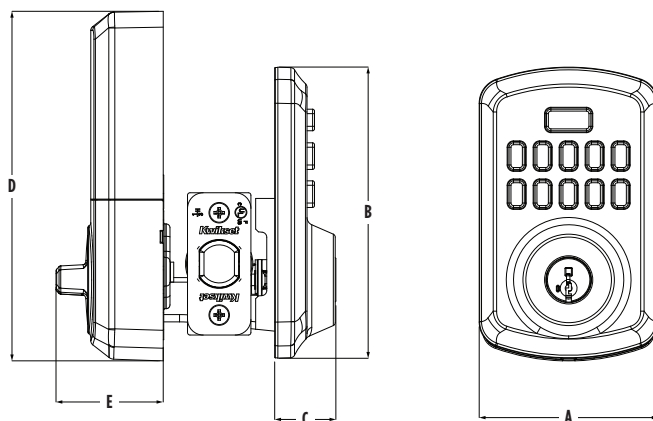

Design	A	B	C	D	E
250 TRS	2 13/16" (71 mm)	4 19/32" (117 mm)	3 1/32" (24 mm)	5 1/2" (140 mm)	1 11/16" (43 mm)

Features

- **VACATION MODE:** Disable the keypad when you're out of town.
- **FEATURING SMARTKEY SECURITY:** Re-key the lock yourself in seconds.
- **12-MONTH BATTERY LIFE:** 4x AA alkaline batteries (not included).
- **EASY INSTALL and BILT App:** Installs with just a screwdriver. BILT 3D interactive instructions provide voice, text and animation guidance for an easy installation.
- **CERTIFIED SECURITY:** BHMA Grade 3. Security, Durability and Finish.

Finishes



Satin Nickel 15



Venetian Bronze 11P



Matte Black 514



Lifetime Polished Brass L03

FINISH AND
LIFETIME WARRANTY*
MECHANICAL
ONE YEAR
ELECTRONIC WARRANTY*

*See kwikset.com/support/warranty for the lifetime limited mechanical and finish warranties and one-year limited electronics warranty.

*Consulte kwikset.com/support/warranty para ver las garantías mecánicas y de acabado limitadas de por vida y la garantía limitada de un año de los electrónicos.



Kwikset

19701 DaVinci, Lake Forest, CA 92610 • Kwikset.com • 1-800-327-LOCK

© 2023 Spectrum Brands, Inc. Kwikset is a trademark of Spectrum Brands, Inc. Lake Forest, CA 92610 • KW-1440130_0523