

# PUMPS

**API Pump Solutions**



 **KENNAMETAL™**  
CONFORMA CLAD

# Conforma Clad™

## A legacy of wear protection

### Kennametal Conforma Clad is a:

- Global solutions provider for wear, heat, and corrosion problems.
- World-class manufacturer of clad components.
- Service provider for the petrochemical and refining industry.

Kennametal Conforma Clad offers custom-engineered solutions to meet demanding needs. For over 30 years, we have worked with end users and OEMs to increase efficiencies and extend the life of critical components, with a focus on refineries and general industrial applications.

Our proprietary processes allow cladding technology to be used in a broad range of applications, including:

- **API Pumps**
- **Shaft Sleeves**
- **Conveyance Piping**
- **Delayed Coker Return Bends**
- **Catalyst Withdrawal Lines**
- **Thermowells**



*Pump impeller after 13 months without Conforma Clad protection*

## The Challenge

Refineries process some of the world's most aggressive fluids and slurries. In these environments pump life can be severely limited by extreme erosive and corrosive wear, leading to increased maintenance costs, reduced reliability, and increased downtime.

Certain pumps within the refinery are exposed to particularly demanding conditions. It is this subset of pumps where our customers have found Conforma Clad™ protection is most required.

- Bottoms Pumps
- Residual Oil Pumps
- Coke Drum Charge Pumps
- Coke Pit Pumps
- FCC Charge Pumps
- Slurry Pumps

## Pump Configurations

We have experience cladding a wide range of pump configurations and sizes.

- Overhung API Pumps
- Between Bearing API Pumps
- Custom Configurations

# What We Offer

Tungsten carbide cladding protecting all wetted pump surfaces

Final finishing of cladding to achieve dimensional requirements

Collaboration with pump OEM to meet required specifications

Longer pump life and increased mean time between repair/failure (MTBR/MTBF)

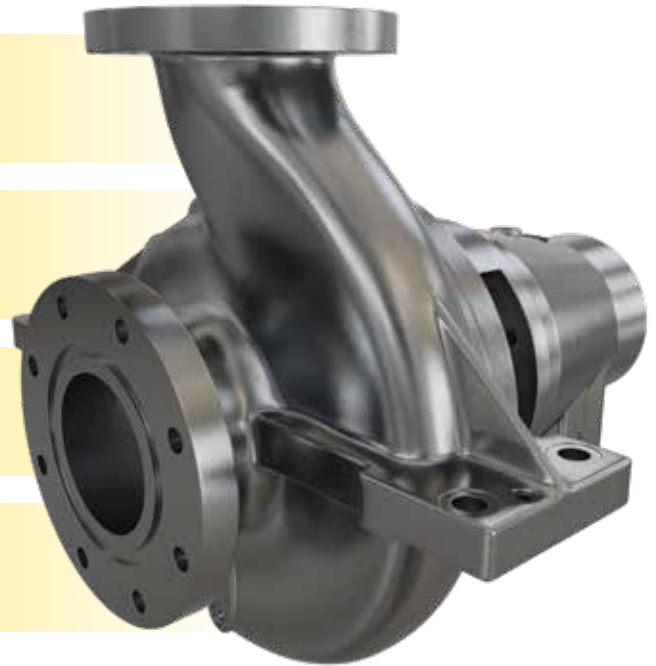

Cover Cladding

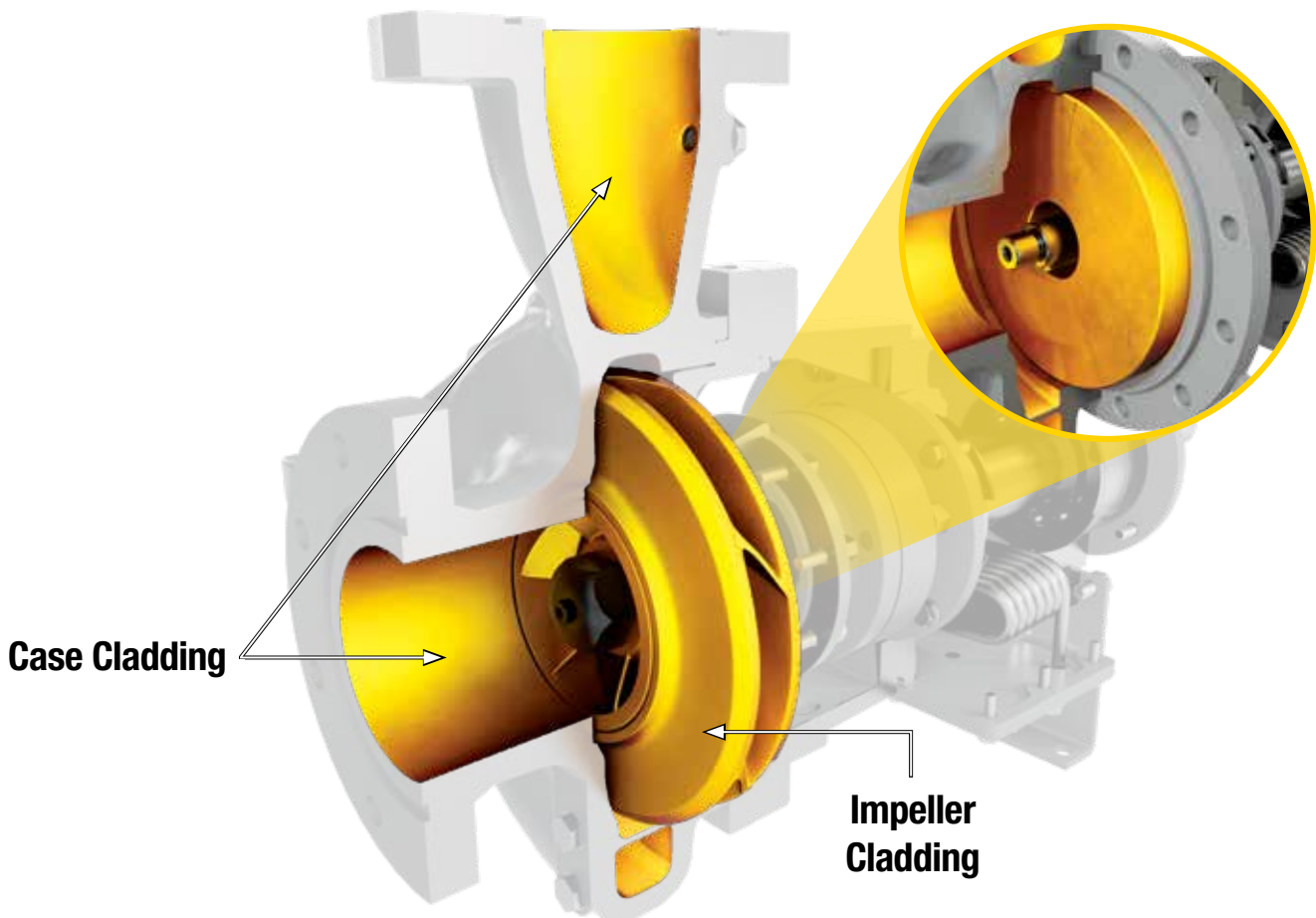

# Cladding Technology

Kennametal Conforma Clad™ are pioneers of infiltration brazed tungsten carbide cladding and have been solving challenging industrial wear problems for over 30 years. Our technology is a result of many years of development and engineering expertise, and customers rely on our cladding when the most critical equipment needs to run longer and more reliably.

## Cloth-Based Cladding Process

Our cladding technology is based on a unique cloth-based delivery system. This proprietary process is used to create a flexible cloth comprised of the required binders and tungsten carbide particles. In its flexible “green” state the cloth can be evenly applied to surfaces such as pump cases and impellers. Parts are treated in a vacuum furnace where a nickel chrome braze alloy forms the cladding matrix and creates the metallurgical bond with the substrate. The result is a cladding that combines the hardness of tungsten carbide with the corrosion resistance of nickel chrome to create a protective barrier with unmatched wear-resistant properties.

## Conforma Clad™ Process Benefits

- Flexibility to clad complex surfaces.
- Controlled cladding thickness across entire surface.
- Uniform carbide distribution.
- Metallurgical bond.



# Cladding Photomicrograph

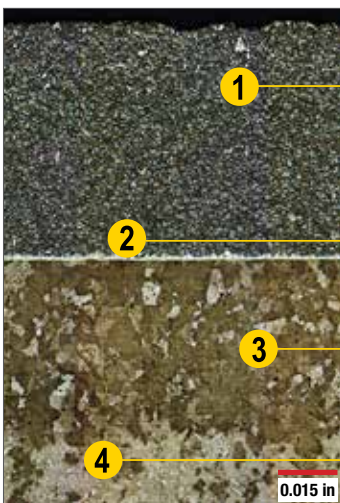

1

### Cladding

Dense tungsten carbide loading with uniform carbide distribution.  
High wear resistance with predictable wear performance from surface to bond line.

2

### Bond Line

True metallurgical bond (>70,000 psi) with high interparticle bond strength.  
High bond strength ensures no flaking, chipping, or spalling.

3

### Diffusion Zone

Minimal dilution — substrate retains uniform properties in diffusion zone.  
No compromise of cladding purity or substrate properties.

4

### Substrate

Heat treatable after cladding process to retain substrate's mechanical properties.



# Cladding Performance

Conforma Clad™ technology delivers full protection for all wetted pump surfaces. Pump cases and impellers with complex geometries and non-line-of-sight features can be challenging to reach and fully protect by other methods.

*Our ability to access and protect all pump surfaces with a metallurgically bonded, dense layer of tungsten carbide sets us apart from other technologies.*

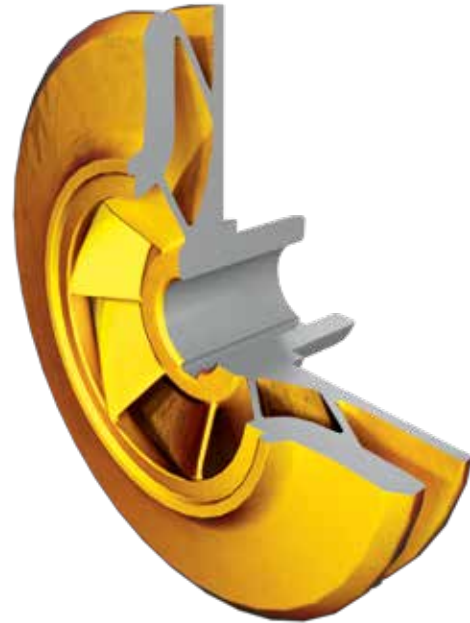

	Conforma Clad™	Weld Overlay	HVOF	Boron Diffusion
Non Line-of-Sight	Good ✓	Poor	Poor	Good
Complex Geometries	Good ✓	Poor	Fair	Good
Relative Thickness	Thick ✓	Very Thick	Thin	Very Thin
Bond Strength	Strong ✓	Strong	Weak	Strong

Specifying Conforma Clad for your pump represents a significant improvement in wear resistance. Our cladding grades offer 2–3 times the erosion and abrasion resistance of competitive overlays. These superior properties make a substantial impact on the life of your pump.

Our cladding grades have been designed to protect your critical equipment from multiple modes of wear, including abrasion, erosion, corrosion, and combinations of these.

## Dry Sand Abrasion Test (ASTM G65)

Higher ARF = Higher Abrasion Resistance

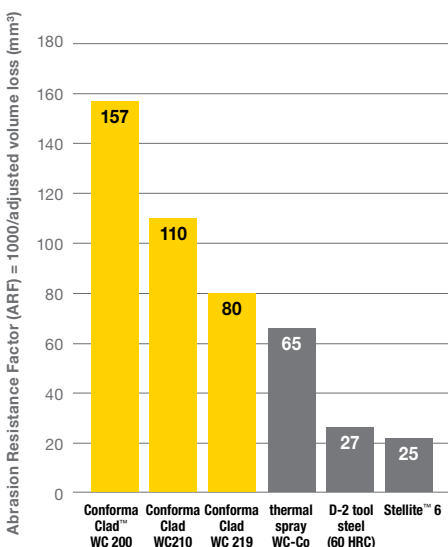

## Corrosion Test (ASTM G31)

10% Hydrochloric Acid at 212°F (100°C)

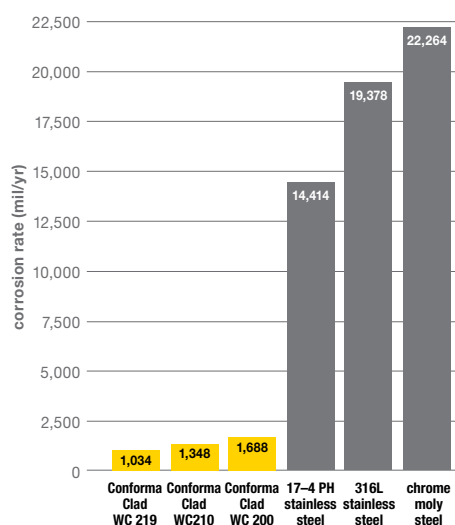

## Erosion Test (ASTM G76)

45° Impingement Angle, 83 m/s, Alumina <63 micron

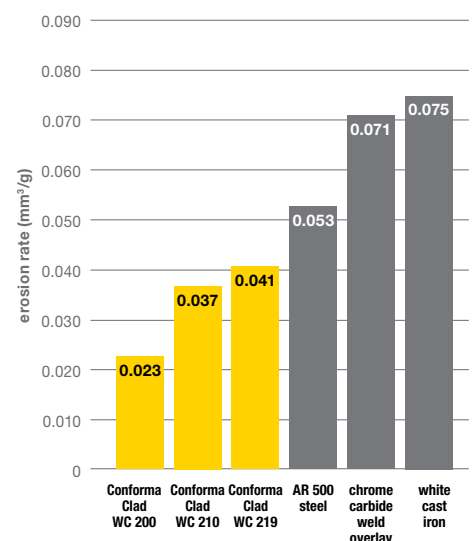

# Proven Solutions

**Other Solutions**

**VS**

**Conforma Clad™**

After 8 months of service (HVOF)



After 13 months of service



After 13 months of service (HVOF)



After 13 months of service



After 6 weeks of service

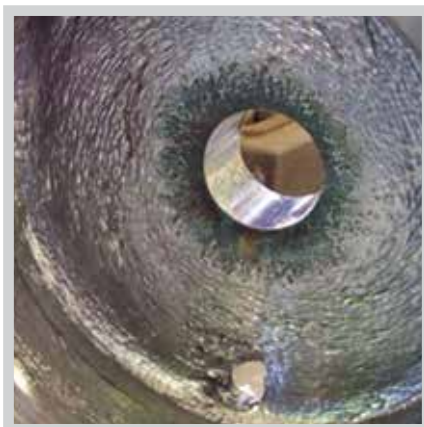

After 12 weeks of service



## Case Study

### The Problem:

A U.S. Gulf Coast refinery was experiencing accelerated internal wear of FCCU cycle oil pumps, often requiring entire case replacements. Pump life was limited to 8–12 months using a tungsten carbide HVOF coating.

### Solutions Evaluated:

- Thermal Spray Coatings
- Weld Overlays
- Boron Diffusion
- Conforma Clad™

Thermal spray coatings and weld overlays did not allow full protection of all pump surfaces and were limited to line-of-sight application. Thermal sprays were also limited in terms of bond strength. Boron diffusion coatings, are, by nature, quite thin and prone to puncture by large abrasive particles.

The Conforma Clad infiltration brazed tungsten carbide cladding solved many of these issues by combining a true metallurgical bond with a dense, uniform distribution of tungsten carbide particles that can be applied to all wetted pump surfaces.

### Outcome:

After 13 months in service, the pump with Conforma Clad protection showed no significant signs of internal erosion. The life of the pump was projected to be 3–4 years and put back in service.

**Contact Conforma Clad for a full copy of this case study**

## API PUMP SOLUTIONS

### For order support:

[k-nalb.cs@kennametal.com](mailto:k-nalb.cs@kennametal.com)  
+1 888 289 4590

Kennametal Conforma Clad  
501 Park East Blvd.  
New Albany, IN 47150  
USA



**WORLD HEADQUARTERS**

**Kennametal Inc.**

525 William Penn Place | Suite 3300  
Pittsburgh, PA 15219 USA  
Tel: 1 800 446 7738  
ftmill.service@kennametal.com

**EUROPEAN HEADQUARTERS**

**Kennametal Europe GmbH**

Rheingoldstrasse 50  
CH 8212 Neuhausen am Rheinfall  
Switzerland  
Tel: +41 52 6750 100  
neuhausen.info@kennametal.com

**ASIA-PACIFIC HEADQUARTERS**

**Kennametal Singapore Pte. Ltd.**

3A International Business Park  
Unit #01-02/03/05, ICON@IBP  
Singapore 609935  
Tel: +65 6265 9222  
k-sg.sales@kennametal.com

**INDIA HEADQUARTERS**

**Kennametal India Limited**

CIN: L27109KA1964PLC001546  
8/9th Mile, Tumkur Road  
Bangalore - 560 073  
Tel: +91 080 22198444 or +91 080 43281444  
bangalore.information@kennametal.com

**kennametal.com | conformaclad.com**