



ENERGY

SUSTAINABLE SOLUTIONS

Energy Technology and Customized Solutions for a New Generation





Contents

- 2–3 Energy Segment Overview
- 4–7 Oil & Gas Drilling
- 8–9 Oil & Gas Production
- 10–13 Oil Sands
- 14–17 Plastics
- 18–21 Petrochemical Industries
- 22–23 Processing Industries
- 24–27 Coal Energy
- 28–29 Large Component Machining:
Thermal Rotor Machining
- 30–31 Large Component Machining:
Turbine Casing Machining
- 32–33 Large Component Machining:
Turbine Blade Machining
- 34–35 Large Component Machining:
Electrical Rotor Machining
- 36–39 Renewable Energy: Wind Turbine
- 40 Renewable Energy: Nuclear
- 41 Renewable Energy: Solar/Waste to Energy
- 42–45 Metalcutting Capabilities
- 46–47 Energy Best Practices/Performance
- 48–49 Advanced Materials
- 50–51 Wear Solutions Capabilities
- 52–53 Sustainable Engineering
 - 54 Surface Technologies
- 55–56 Global Contacts

ENERGY INDUSTRY

Kennametal leads the way with innovation, engineering, and service in standard and customized components, products, and solutions.

THE KENNAMETAL PORTFOLIO

Kennametal is more than a supplier of tooling solutions. With a thorough understanding of the energy industry's process and application challenges, we proactively address production concerns to deliver productivity to customers seeking peak performance in demanding environments. Kennametal's success is based on our capabilities — our ability to work with you on customized solutions to optimize your results and our willingness to engage with a broad spectrum of materials, metalworking solutions, application and custom component manufacturing, and supply expertise. Our drive for success, enabled through our advanced materials sciences, application knowledge, design expertise and commitment to a sustainable environment, results in a broad portfolio of innovative, custom, wear-resistant solutions.

ENVIRONMENTAL SUSTAINABILITY

At Kennametal, we are deeply committed to designing and manufacturing environmentally responsible solutions that deliver high performance and proven value. Along with our decades of experience, the synergies of superior engineering, leading technology, and tailor-made solutions offer customers some of the most effective opportunities for sustainable manufacturing in the industry.

ENERGY



OIL & GAS DRILLING

Kennametal helps improve your rate of penetration as well as wear resistance for more consistent drilling by offering custom components and material systems designed for speed, flexibility, and extended life.



OIL & GAS PRODUCTION

Using our material science and manufacturing expertise, Kennametal can collaborate with your engineers to find an erosion-, abrasive-, and corrosion-wear solution for your components.



OIL SANDS

From nozzles to conveyance systems, Kennametal's material solutions can provide considerable improvements in wear life and productivity within the harsh environment of oil sands.

Energy Technology and Customized Solutions



PLASTICS

Globally recognized as a leader in the polyolefins industry, Kennametal offers several wear-resistant solutions for your plastics equipment — from extruders to conveyance systems.



COAL ENERGY

Kennametal can help prevent unscheduled maintenance by finding solutions for your systems and components — from fans to pumps — making them more reliable, efficient, and longer lasting.



PETROCHEMICAL INDUSTRIES

Corrosion and abrasion often determine component life. Kennametal provides wear solutions for barrels, screws, pump impellers, housings, and shafts, as well as bimetallic Hot Isostatic Press (HIP) rods.



LARGE COMPONENT MACHINING

Kennametal boasts a wide range of knowledge and proven solutions to machine critical features on the most complex electrical rotors including flex slots, coil slots, and integrated gear milling technology.



PROCESSING INDUSTRIES

Whether it is within the food and feed, cement, pulp and paper, or mining industry, Kennametal has the materials to solve your wear and corrosion problems. Our custom-designed wear products will keep your equipment operating longer between maintenance sessions.



RENEWABLE ENERGY

By providing manufacturing solutions to increase capacity, productivity, and quality, Kennametal can meet the challenges that manufacturers in the wind, nuclear, solar, and waste-to-energy industries face every day.

OIL & GAS DRILLING

Kennametal offers custom components and material systems to help extend the life of down-hole tools such as drill bits, motors, and critical wear components in the bottom-hole assembly. We provide the toughness and wear resistance needed to improve rate of penetration and consistently drill each section on a single trip. From design to implementation, we understand the requirement for both speed and flexibility.



CLADDING

RADIAL BEARINGS

- › Increase bearing life.
- › Reduce operational costs.
- › Improve motor performance.
- › Enhance drilling accuracy.
- › Unsurpassed quality standards.



COMPACT, INSERTS, BUTTONS ROCK BIT APPLICATION



- › Advanced carbide grades and enhanced cutting structures maximize rate of penetration (ROP) and total bit footage.
- › Designed to withstand drilling through any rock formation.
- › Standard hole and insert sizes mean reduced inventory.

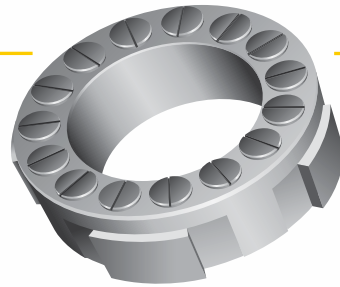

BRAZING THRUST BEARINGS

- › Proprietary carbide formulas assist enhanced ring design.
- › Brazed PCD buttons provide greater rigidity and support, enabling shorter thrust-bearing assembly.
- › Enhances stability and accuracy of Measurement While Drilling (MWD) tool.
- › Allows for better maneuverability resulting in tighter steering and turning radius.



OIL & GAS DRILLING

BIT COMPONENT TECHNOLOGY Whether you're using tri-cone or fixed cutter bits, Kennametal offers ultimate proven solutions to deliver the best component parts for superior drilling productivity. Our expertise in metallurgical and material science allows us to formulate, design, and deliver component drill bit parts to your exacting specifications.

WEAR PROTECTION

HARD FACING & HARD BANDING

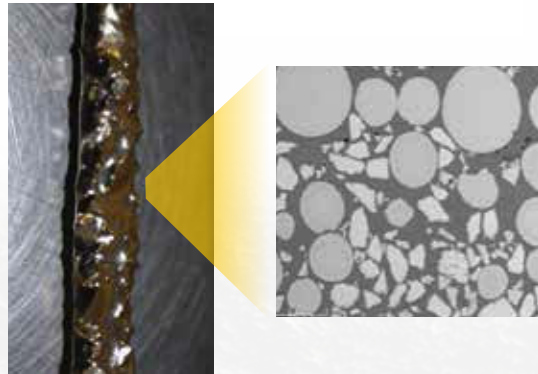

- › Based on macrocrystalline, cemented tungsten carbide, and cast carbide.
- › Can add directly to the welding puddle.
- › High thermal stability.
- › Excellent wear and impact resistance.
- › Rods are available in a variety of carbide grain sizes.





PCD SUBSTRATES

- › Made with quality carbide grades that prevent clusters from forming close to the surface.
- › Designed to allow PCD compacts to be more easily and rigidly mounted.
- › Superior substrate to PCD bond reduces fracturing during interrupted and severe cuts.



BIT NOZZLES

- › Wide variety of nozzles, including threaded, standard, and extended, for all bit designs.
- › Precision manufactured for optimal nozzle location and arrangement, improved flow velocity, and reduced pressure loss.
- › World-class engineering to meet customer-designed specifications.



POWDER & ALLOYS

- › Maximum abrasion resistance.
- › Maximum corrosion resistance.
- › Absence of porosity enables high strength.
- › Homogenous and fine microstructure.
- › No phase segregation.

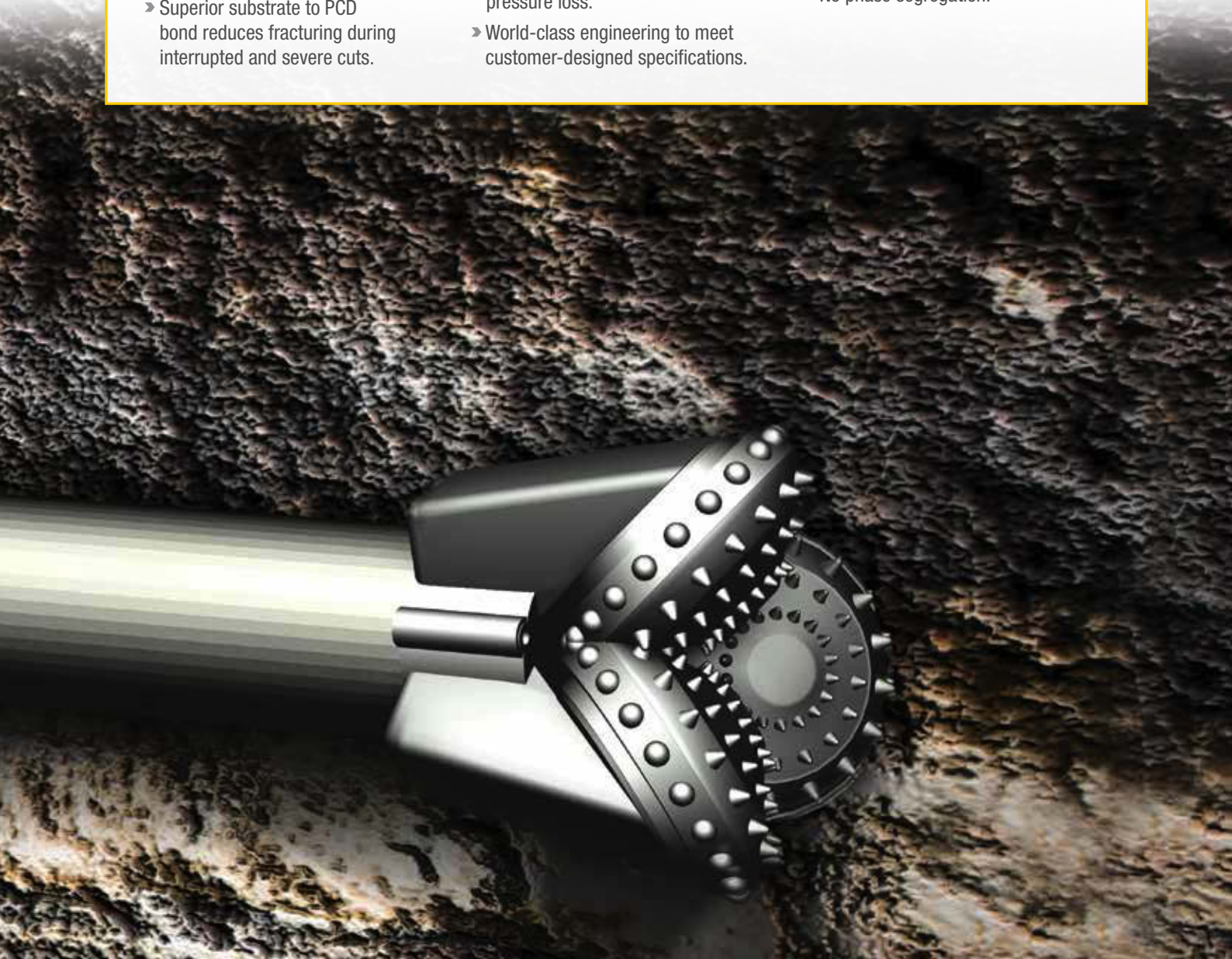

OIL & GAS PRODUCTION

Kennametal works with your engineers to apply material science and manufacturing expertise to the components that are often the first barrier between demanding environments and the production system. Reliable service over the life of the reservoir requires innovative designs that can stand up to the increasingly harsh conditions of aging and remote fields. Kennametal is an expert in erosion-, abrasive-, and corrosion-wear solutions for flow control valves, chokes, subsea systems, or anywhere product life is measured in years.

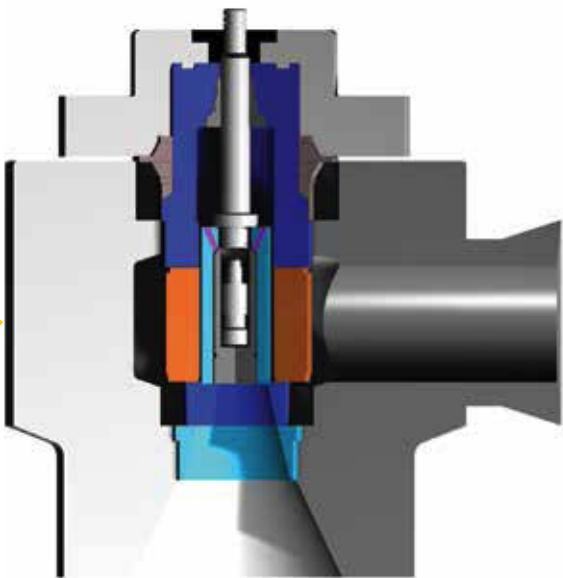

FLOW CONTROL CHOKES

- › Sophisticated flow control and choke assemblies.
- › Customer-specific solutions.
- › Precise, complex assemblies.

HOT ISOSTATIC PRESS (HIP) SUBSEA COMPONENTS & VALVE BODIES

- › Highest flexibility in construction.
- › Short lead times.
- › Less welding.
- › Less machining.
- › Less weight.
- › Isotropic characteristics.



FRACTURING MANIFOLD



- Increased mass metal removal (MMR).
- Standard and customized milling cutter bodies with standard inserts.
- Increased penetration rates with customized holmaking tools.
- Improved surface finish and hole quality.
- High-performance tapping and thread milling.

DID YOU KNOW

“We machine flanges for wellheads, connector manifolds, and subsea components used in oil production,” says Steve Eldridge, shop superintendent for Sun Manufacturing in Houston. On a subsea flanged spool of 4130 steel, Sun was drilling 8" of depth using pecking cycles and was feeding at about an inch per minute using a spade drill. “With the KSEM PLUS,” we were able to drill the 8" of depth and the feed was 10 times faster.” What could have taken more than eight hours to complete 24 holes was accomplished in 38.4 minutes. “The KSEM PLUS paid for itself on the first part.”



DOWN-HOLE INTELLIGENT VALVE

- Intelligent well solutions.
- Chokes are tested and approved for down-hole applications at 25,000 ft (7.620m) or more.
- Carbide components are custom designed for specific customer needs.
- Valve flow is controlled from the surface.



LAND-BASED ONLY API BALLS & SEATS

- Ball and seat are check valves that facilitate lift.
- Ball and seat—pump jack is the most common.
- American Petroleum Institute (API) Standards.

OIL SANDS

The extraction of petroleum from unconventional deposits poses an array of challenges. The combination of clay, sand, water, and bitumen, in addition to the techniques used to liquefy and transport this material, creates a wear environment not encountered in any other industry. Kennametal, with its full portfolio of wear solutions and technical expertise, is uniquely positioned to meet these challenges — and help you succeed.

TRANSPORT WEAR SOLUTIONS BUCKET & BED LINERS

- Field measured to ensure custom fit.
- Kit includes liners, attachments, and weld consumables.
- Utilize Tri-Braze™ for maximum impact resistance and Tri-Braze Dura-Plus™ for maximum wear resistance.

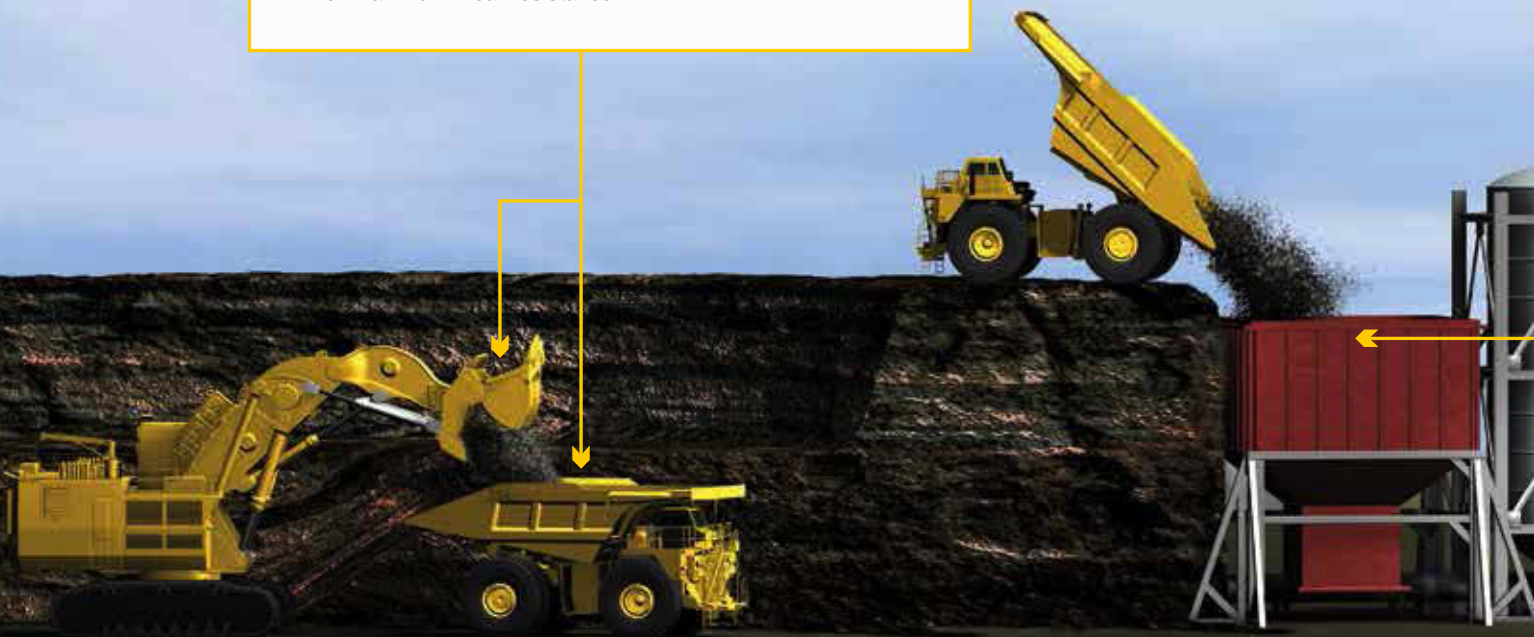



SLURRY PREPARATION

PRIMARY CRUSHERS & SECONDARY SIZERS

- › EASY-PULL™ notches are engineered to increase productivity, plus allow for quick and safe removal.
- › Large base provides excellent block protection.
- › Superior wear resistance over abrasion resistant (AR) and welded overlay products.
- › Tungsten carbide body offers superior wear life.
- › The metallurgically bonded tungsten carbide in the body of the tool allows for superior impact strength.
- › Extra large bit weighs 35 lbs (15,88 kg).

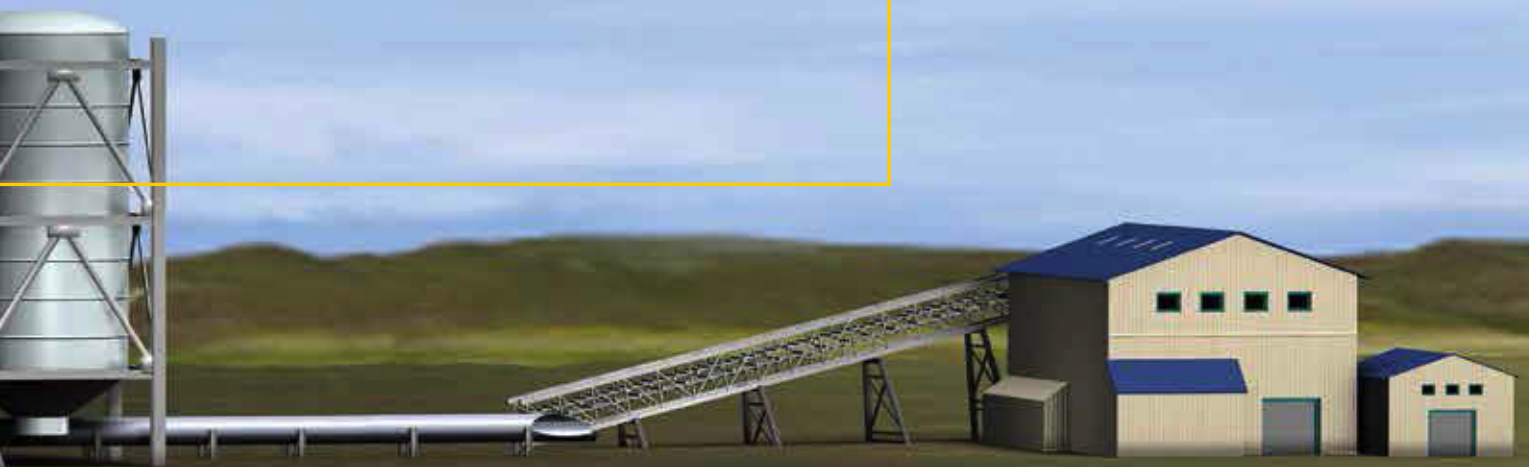

OIL SANDS

HYDROTRANSPORT & TAILING TRANSPORT

SUPER C™ LINED PIPE



- › Highest carbide percentage available in the industry.
- › Single- and double-layer deposits available.
- › Diameters ranging from 14–32" (355–812mm).
- › 5D and 3D elbows available.

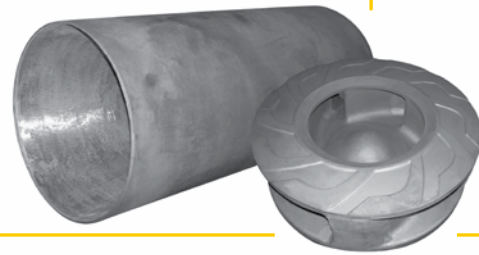

PUMP IMPELLERS, HOUSINGS, SHAFT SLEEVES

- › Last three to six times longer the life.
- › Less leakage flow.
- › Less frequent packing adjustments.
- › Reduced wear allows design clearances to be maintained longer.



BITUMEN EXTRACTION HYDRO HEATER TUBES

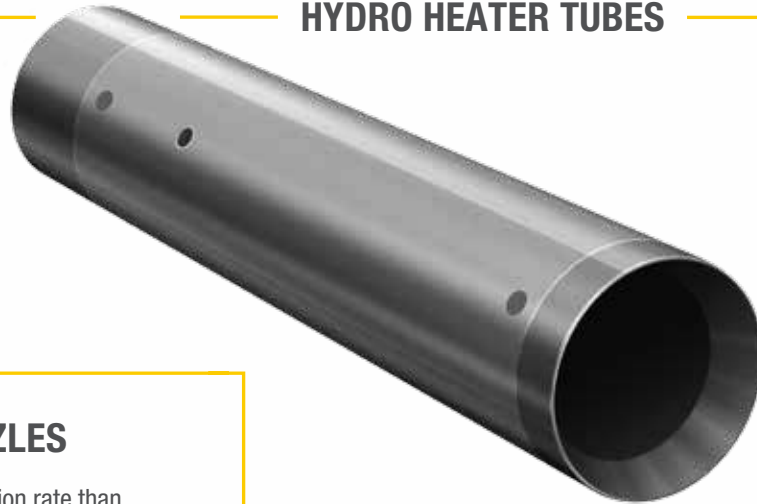

VENTURI NOZZLES

- › 40% greater production rate than straight bore nozzles.
- › Tapered design accelerates and evenly distributes the abrasive.
- › Designed for use with a 1" (25,4mm) I.D. blast hose for maximum cutting action on hard-to-clean surfaces.

- › Solid carbide lined combining tube lasts 10 times longer than chrome white iron version.
- › Ideal wear surface for steam bitumen flow.
- › Increased productivity with less downtime.
- › Available with automated sleeve adjustment to maximize wear life.



→ HYDROTRANSPORT

→ BITUMEN EXTRACTION

→ UPGRADING

→ TAILING TRANSPORT

PLASTICS

Kennametal provides valuable solutions for high-volume production with tight product quality requirements. Tungsten carbide, properly applied, is often the material of choice for wear-resistant pelletizing dies, knives, high-pressure plungers, barrels, and screws. Our specialized HIP (Hot Isostatic Press) capabilities offer some of the most uniform material qualities available.

LDPE PROCESSING

HYPERCOMPRESSOR PLUNGERS

K94 Carbide — The Industry Standard Plunger Material

- › Made with a secondary HIP operation.
- › Exact size control during the plunger grinding process.
- › Uniform, high-polish surface finish.
- › On-site non-destructive testing available.
- › Up to 177,4mm (7") in diameter and 1.524mm (60") in length.

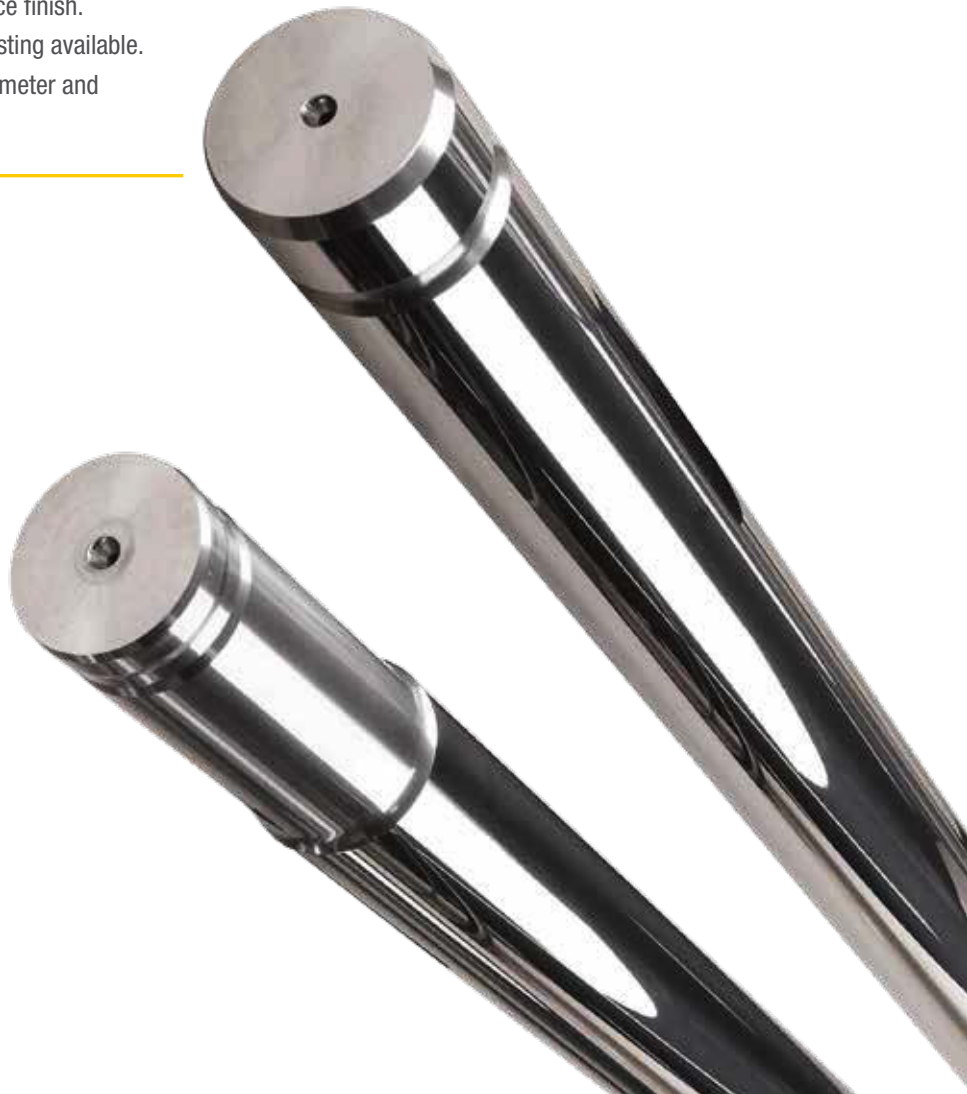



POLYOLEFIN EXTRUSION

UNDERWATER PELLETIZING PLATES



PD-21 Titanium Carbide

- › Outstanding thermal retention.
- › Promotes underwater startups.
- › Reduces orifice hole freeze-off and melt fracture.
- › Excellent wear resistance.



PLASTICS

Kennametal provides valuable wear solutions for high-volume production with exacting product quality requirements. Our infiltration brazed tungsten carbide is often the material of choice for erosion-, abrasion-, and corrosion-resistant extruder barrels, liners, dies, pipes, elbows, valves, and chutes — extending component life by up to 15 times longer than with unprotected components.

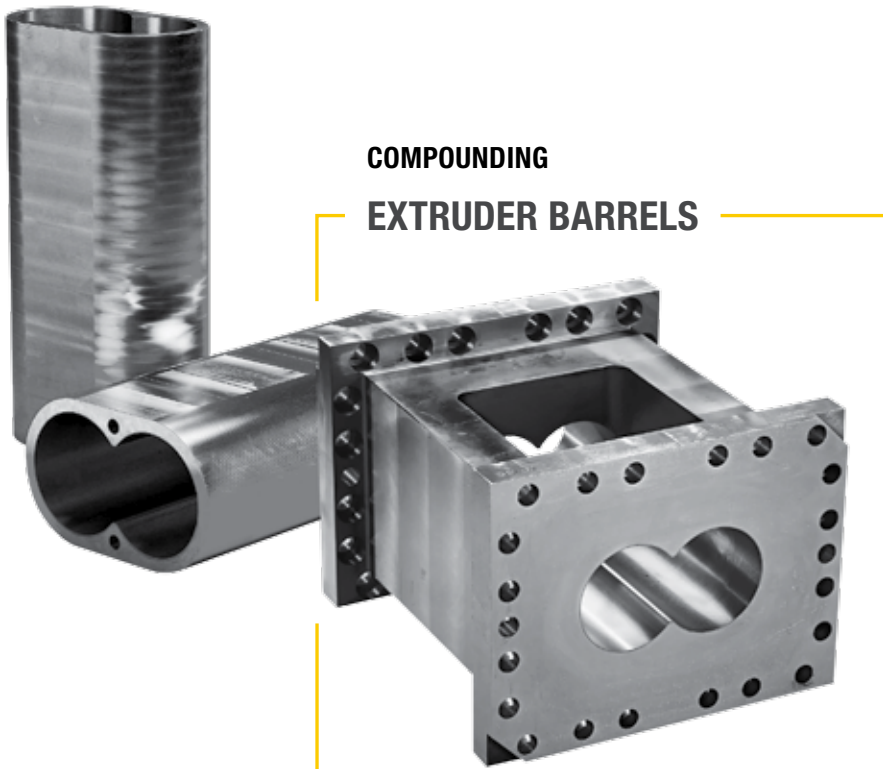

COMPOUNDING

EXTRUDER BARRELS

- › Improved resistance against erosion, abrasion, and corrosion.
- › Enhanced heat transfer.
- › Reduced risk of catastrophic failure.
- › Consistent production quality.

DID YOU KNOW !

Due to the extreme abrasiveness of AMODEL polyphthalamide pellets, which are composed of up to 50% glass, Solvay Advanced Polymers, located in Augusta, GA, was experiencing daily piping blowouts, particularly in the elbows of their conveyance system. After experimenting with long-radius-bend, pocket-back-deflection, ceramic-lined, glass and glass-lined, and tungsten-carbide-coated elbows, Solvay turned to Kennametal, dramatically increasing the life of their elbows from 21 days to more than nine years and significantly decreasing annual labor, parts, and lost-product costs.



MATERIAL MANAGEMENT

CONVEYANCE COMPONENTS

- › Prevent the loss of product.
- › Eliminate or reduce blowouts.
- › Reduce maintenance costs and downtime.
- › Avoid cross contamination.

COMPOUNDING

SCREW BLANKS

- › Maintain critical screw/barrel clearances.
- › Improve process control.
- › Ensure consistent physical properties.
- › Optimize outputs.



PETROCHEMICAL INDUSTRIES

Erosion, abrasion, and corrosion often determine component life. Kennametal provides wear solutions for pump impellers, housings, shafts, and other rotating as well as fixed equipment.



PROTECTIVE HOUSING THERMOWELLS

- › Designed for severe, high-temperature environments.
- › Erosion-resistant engineering for superior performance.
- › Wide variety of standard sizes and configurations to meet customers' needs.

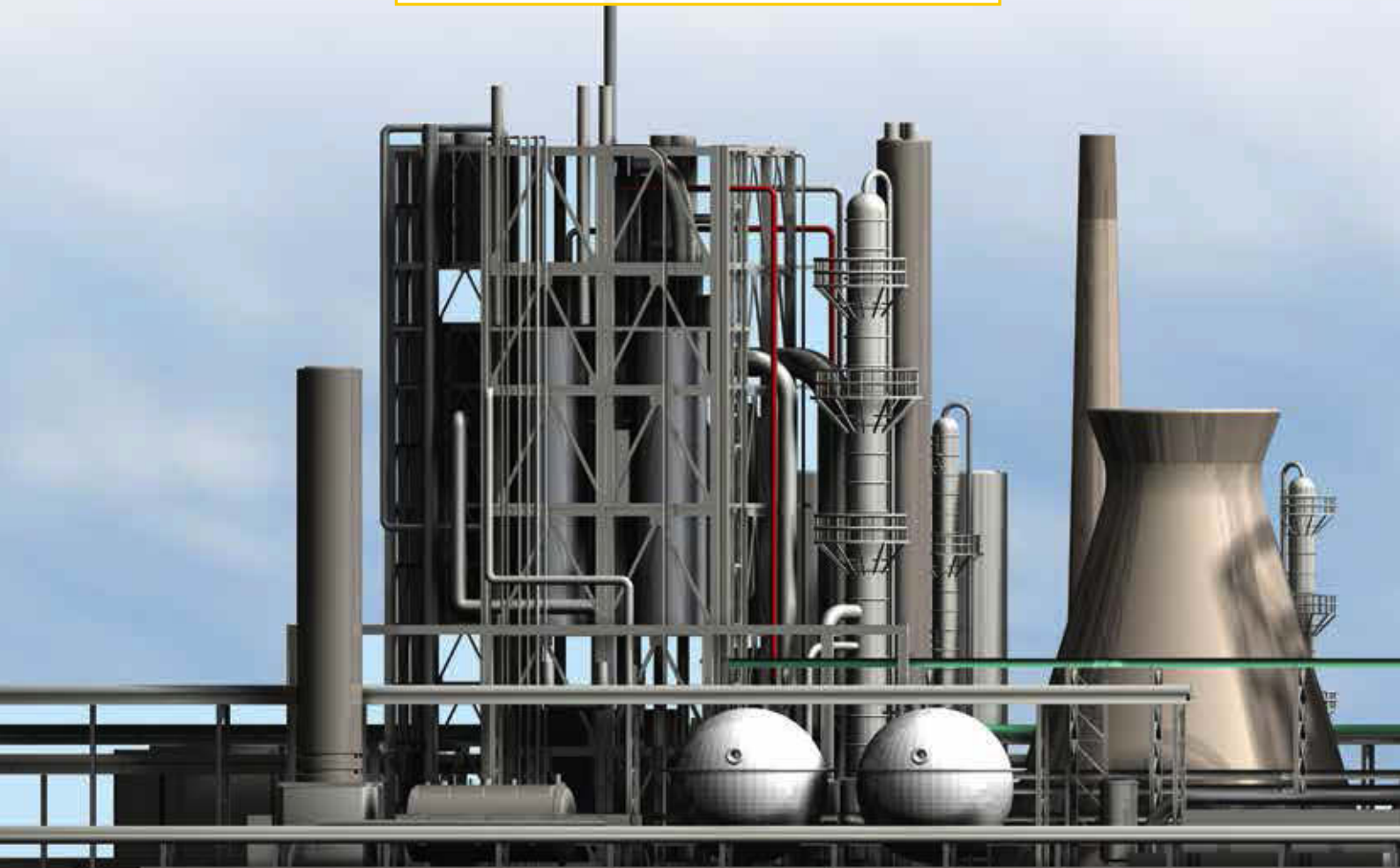

CONVEYANCE

PUMPS

- › Extends pump component life up to five times.
- › Casings, suction liners, wear rings, and impellers.
- › Capable of cladding a variety of substrates: carbon steels, stainless steels, and duplex materials.
- › Ability to clad components up to 1.625m (64") in diameter and up to 2700 kg (6000 lbs).



PETROCHEMICAL INDUSTRIES



CONVEYANCE AND TUBES

CONVEYANCE

- › Greatly reduce blowout potential.
- › Prevent lost product.
- › Reduce maintenance costs and downtime.
- › Avoid cross contamination.
- › Lengthen run time between scheduled outages 10–15 times longer than with unprotected components.
- › Reduce component weight.
- › Replaceable wear plates for point of impact in cyclones.





DIVERTERS

- › Greatly reduce blowout potential.
- › Reduce maintenance costs and downtime.
- › Avoid cross contamination.
- › Lengthen run time between scheduled outages 10–15 times longer than with unprotected components.
- › Reduce component weight.

BOILER TUBES

- › Extends tube life four to five times longer.
- › High coefficient of heat transfer and ability to withstand severe thermal shock.
- › Fully protects pendants, U-bends, and complex shapes.
- › Linear wear offers predictable life.



PROCESSING INDUSTRIES

Whether it is within the food and feed, cement, pulp and paper, phosphate, or other processing industries, Kennametal's wear solutions can significantly increase equipment life in extreme environments. We offer full-service solutions to our customer including: wear assessment, solution design and engineering, cladding fabrication and applications, installation support, and ongoing wear monitoring and consultation.

AQUAFEED

SINGLE SCREWS & LINERS

- › Superior erosion, abrasion, and corrosion resistance.
- › Increases life four to eight times longer than original equipment.
- › Reduces total maintenance costs.



BARRELS

- › Maintain critical tolerances.
- › Tighter process control.
- › Consistent product quality.
- › Consistent throughput.

FOOD & FEED INDUSTRIES

DIES & WEAR PLATES

- › Kennametal cladding extends die life up to seven times.
- › Consistent quality of the finished product.
- › Predictable maintenance schedule.



CONVEYANCE

- › Dramatically extend component life.
- › Extremely resistant to abrasive, corrosive, and erosive wear.
- › Resists chipping and spalling.
- › Greatly reduce blowout potential.
- › Reduce component weight.
- › Avoid cross contamination.
- › Reduce downtime and maintenance costs.

AUXILIARY EXTRUDER EQUIPMENT

- › TS barrels, TS barrel liners, SS barrels, and screws.
- › Up to seven times component life.
- › Improves process control and quality.



PULP & PAPER

INDUSTRIAL FANS

- › Superior weight-to-erosion-resistance ratio.
- › Resists chipping and spalling.
- › Improves fan efficiency.
- › Reduces costly downtime.
- › Prevents catastrophic blade detachment.



WOOD CHIP FEED SCREWS

- › Extended equipment life increases productivity.
- › Fewer shutdowns and component changes.
- › Longer run time between maintenance windows.
- › Reliable performance.
- › Uniform and predictable rate of wear.

GENERAL INDUSTRIAL

PUMPS

- › Extended pump life increases productivity.
- › Fewer equipment shutdowns and component changes.
- › Longer run time between maintenance windows.
- › Reliable pump performance.
- › Uniform and predictable rate of wear.



PIPING

- › Greatly reduces blowout potential.
- › Prevents lost product due to undetected blowouts.

AGITATORS & MIXING PADDLES

- › Kennametal cladding solutions extend the life of rotating components.
- › Reduces component replacements and downtime.

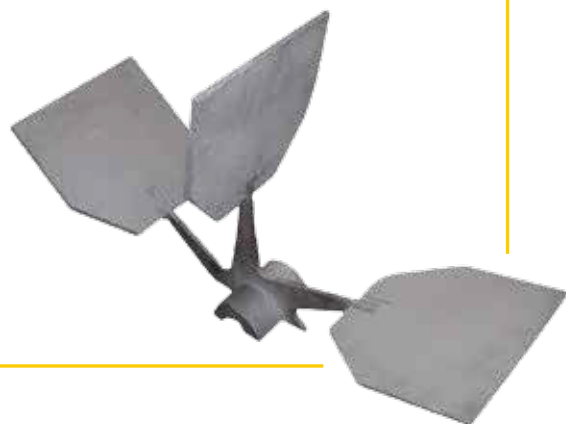

COAL ENERGY

With a history of delivering cost-effective wear solutions to coal-fired power, Kennametal's brazed tungsten carbide cladding is proven to reduce the effects of abrasion, corrosion, and erosion caused by fly ash and other particulate matter. Our cladding solution significantly extends the life of fan blades, ash conveyance systems, and components for coal burners and pulverizers. Use the advantages of our expertise to: avoid unscheduled downtime, reduce maintenance costs, increase productivity, eliminate or reduce blowouts, and prevent lost product during conveyance.

COAL PREP — PULVERIZING WEAR PLATES

- › Low carbon and sulfur contents.
- › Sulfide shape control.
- › Excellent toughness and internal cleanliness (A578-96 level C).
- › Weldable, using conventional welding processes (SMAW, GMAW, SAW).
- › Specifically designed for improved formability and good machinability.

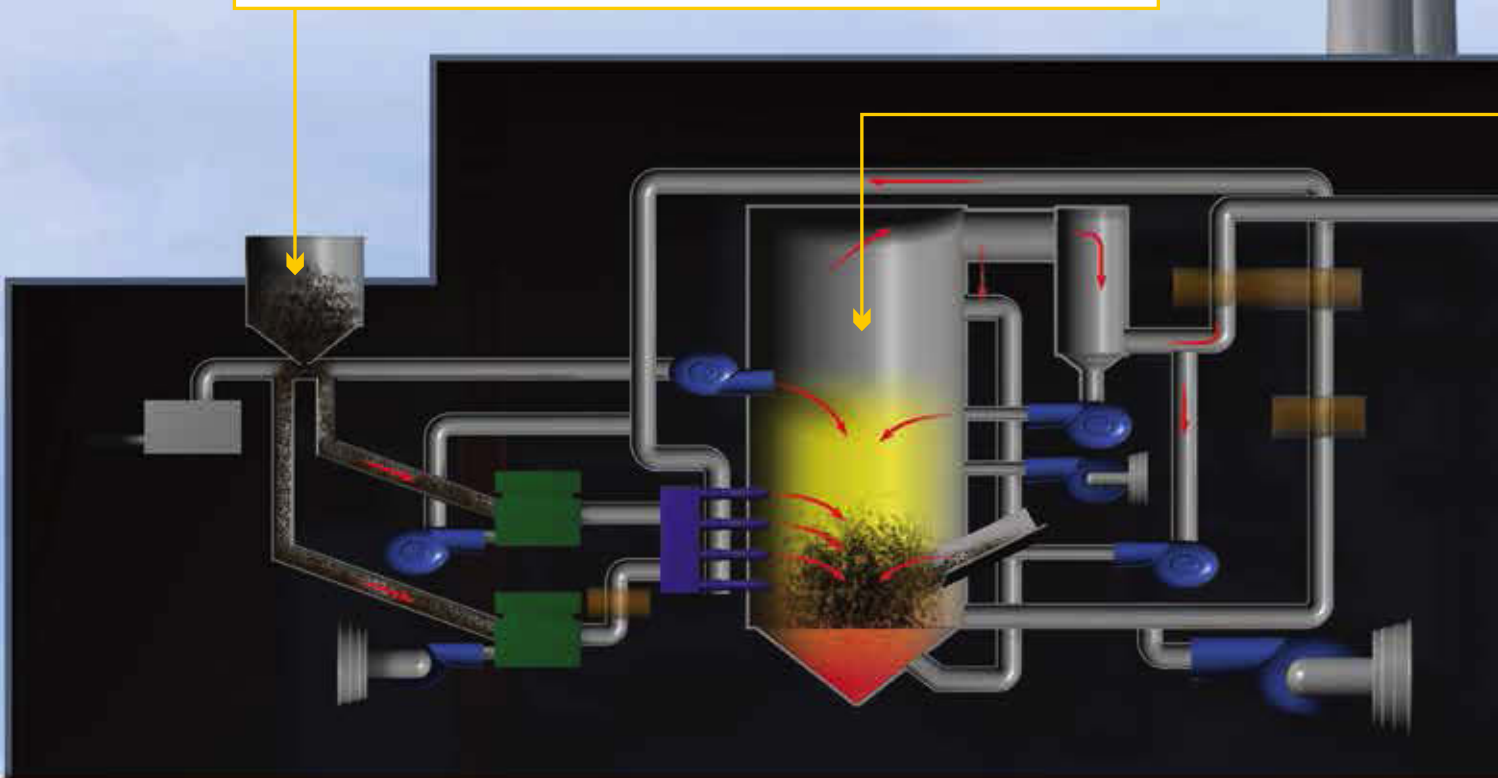



CLADDING

BOILER RIFFLES

- Superior weight-to-erosion-resistance ratio.
- Extended service life.
- Balanced combustion.



BURNER COMPONENTS

- Extended component life increases productivity with fewer equipment shutdowns and component changes.
- Decreased burner component wear leads to better NOx (Nitrous Oxide) emission performance.
- Superior erosion resistance.



BOILER TUBES

- Erosion protection in soot blower lanes eliminates the need for tube shields.
- Linear wear enables extended, predictable life.
- Meets the requirements of the ASME Boiler and Pressure Vessel Code (S Stamp).

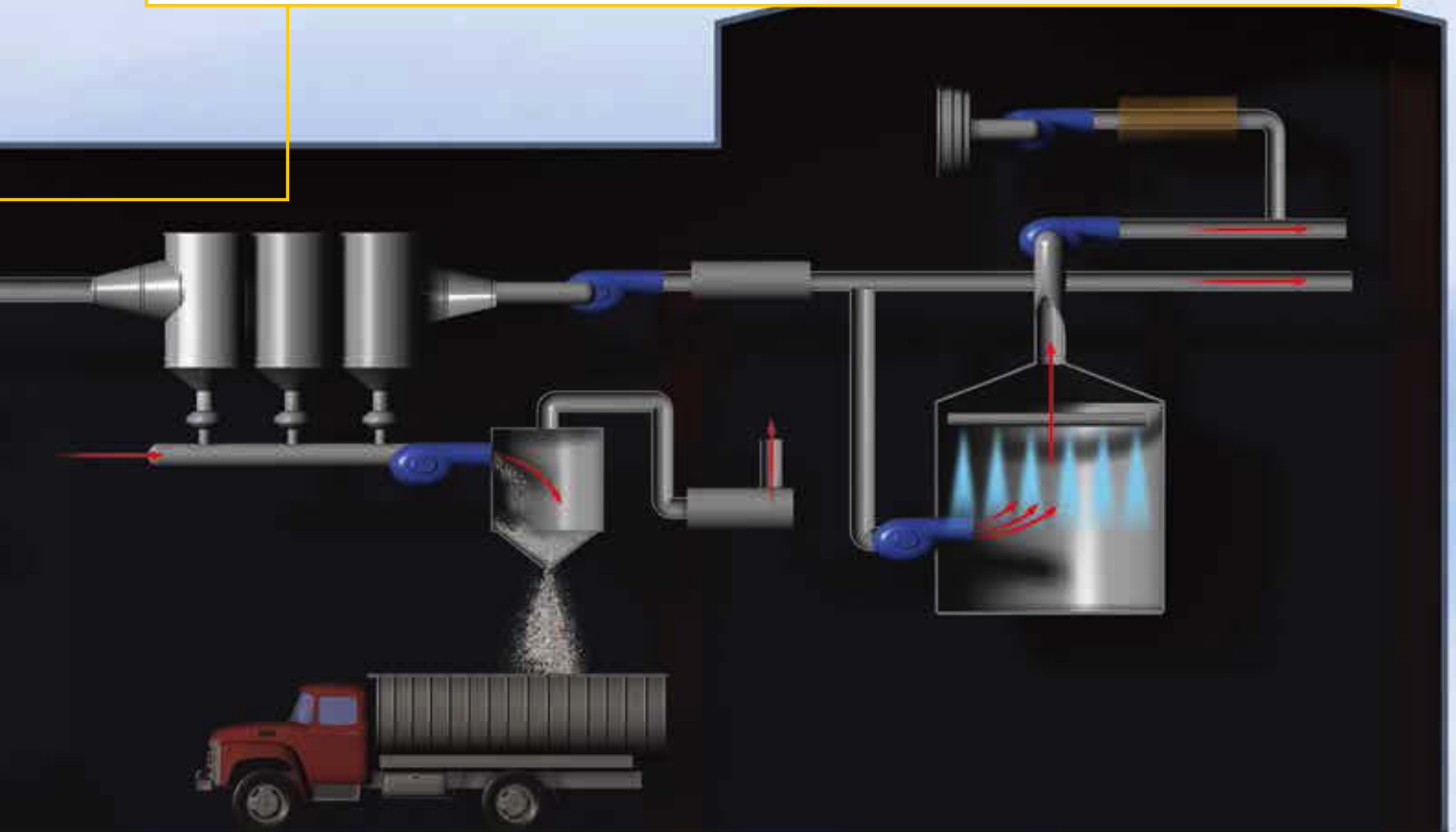

COAL ENERGY



CONVEYANCE

FANS

- › Superior weight-to-erosion-resistance ratio.
- › Resists chipping and spalling.
- › Reduces costly downtime.
- › Prevents catastrophic blade detachment.
- › Protection of leading and trailing edges, centerplate weldment areas, and fan inlet hubs.



PIPE REDUCER

- › Lowers maintenance costs and unscheduled downtimes.
- › Protects against vibration, shock and thermal distortion as well as leakage.
- › Kennametal cladding solutions provide better protection at a lighter weight compared to conventional cladding solutions.



I.D. PIPE

- › Outlasts induction-hardened pipe by a factor of 3:1.
- › Pressure vessel welding available on request.
- › Can be pressure tested for applications up to 300 psi.
- › Super C™ chromium carbide overlay is ideal for extreme-wear applications.

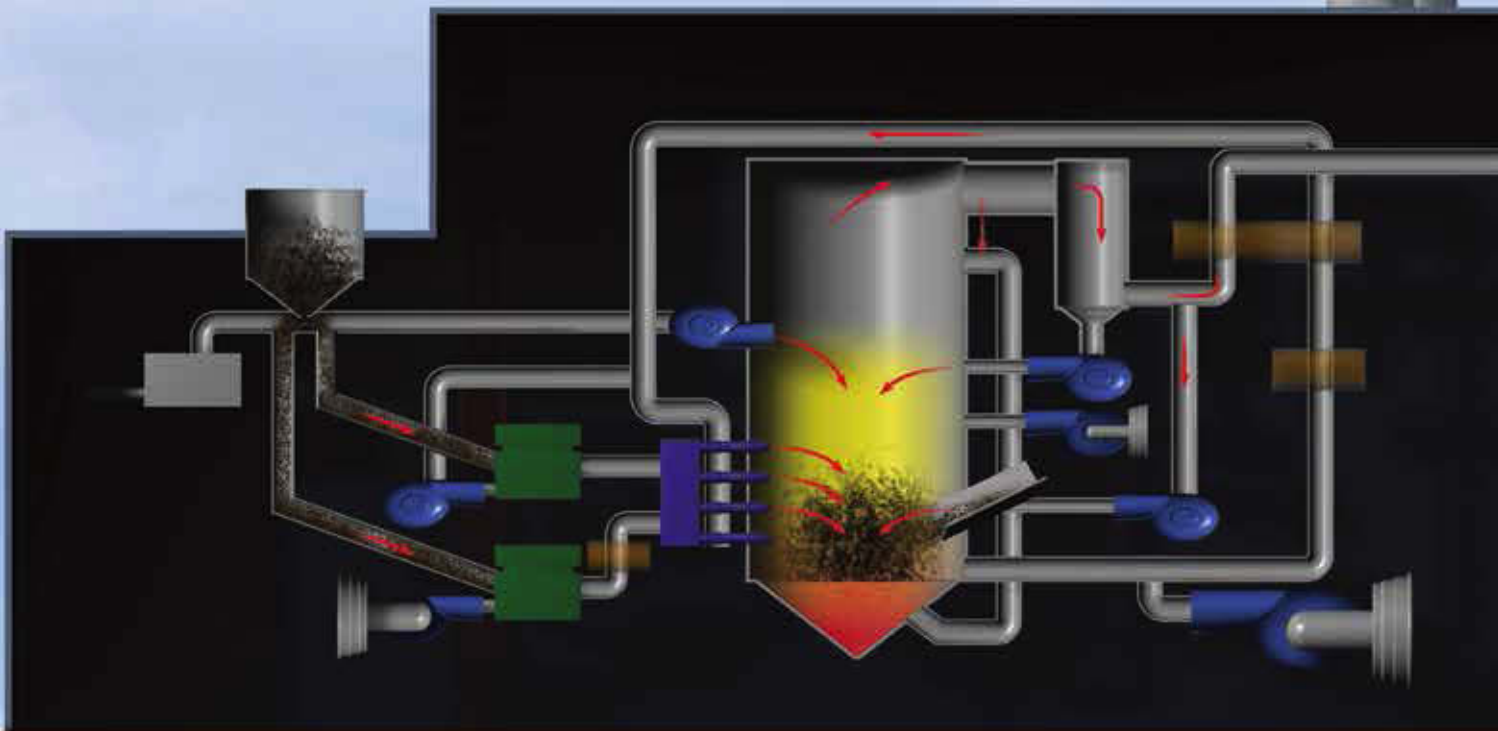

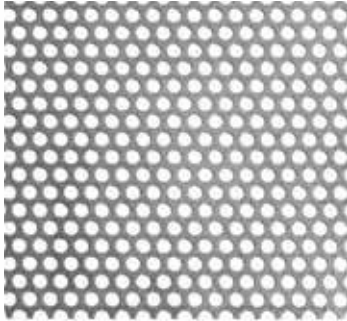

ENVIRONMENTAL

SCR SCREENS

- Five to eight times longer life than stainless steel screens.
- Increased resistance to impact and cyclic fatigue.
- Excellent protection against popcorn ash plugging.

TRANSPORT PIPING

Super C™ Lined Pipe

- Highest carbide percentage available in the industry.
- Single- and double-layer deposits available.
- Diameters from 355–815 mm (14–32").
- 5D and 3D elbows available.

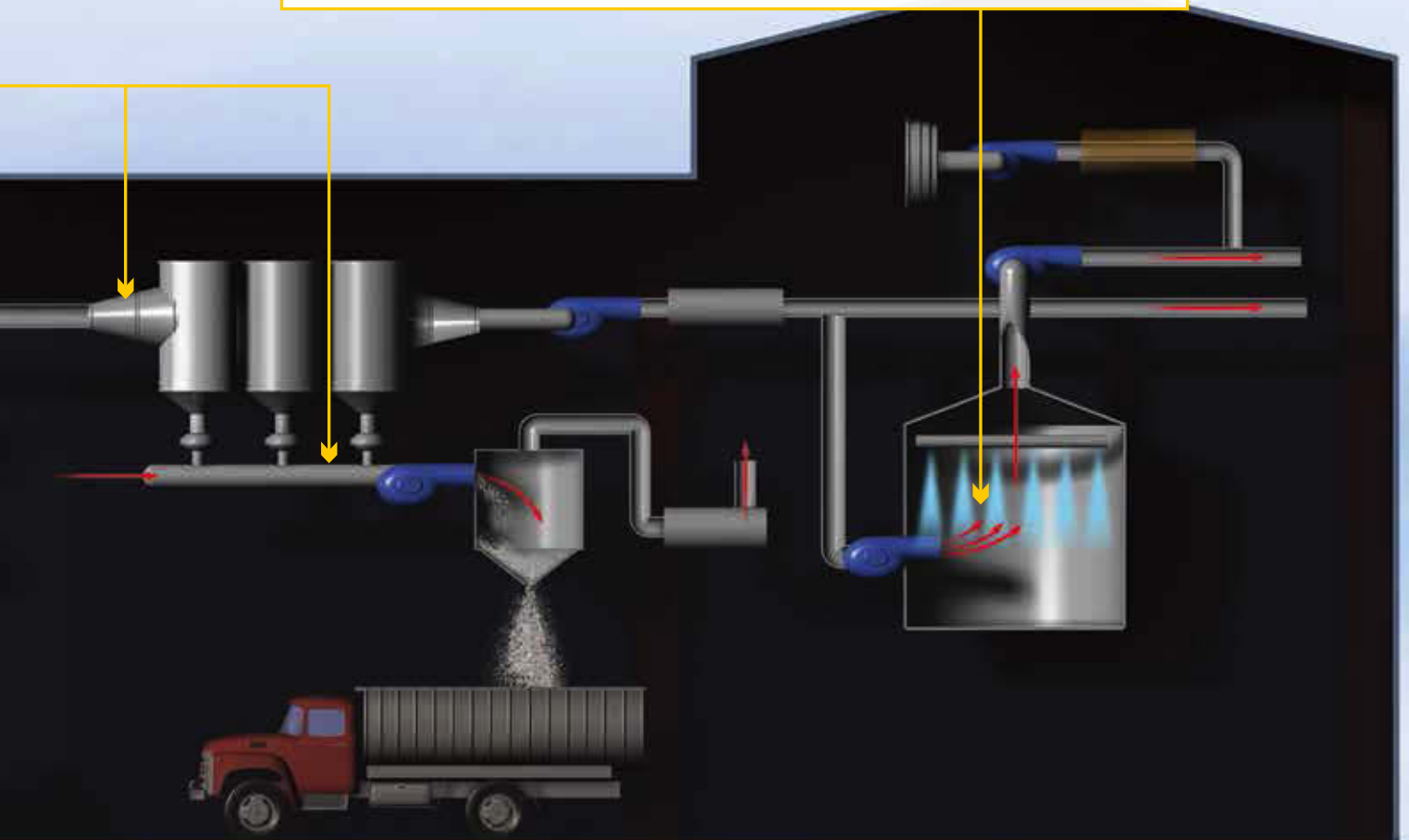

LARGE COMPONENT MACHINING

THERMAL ROTOR MACHINING From rotor journals and coupling halves to sealing strips and grooves, Kennametal specialists can help you select the right tools — slotting, roughing, facing, and grooving — for your turbine machining applications.



ROUGH TURNING & GROOVING HEAVY-DUTY TOOLHOLDERS

Roughing

- › Rigid insert top clamp system.
- › Strong inserts with raised chipbreaker.
- › Effective chip control with stronger cutting edges.
- › Carbide and ceramic inserts.

Grooving

- › Stable clamp system with face contact.
- › Free chip flow.
- › Positive chip form geometry.
- › Wide range of insert widths available.

FINISH TURNING

KM4X™

- › Turning, facing, and grooving.
- › Vast range of toolholders, mountings, and inserts for heavy-duty turning.
- › Proven history of success in extremely demanding applications.

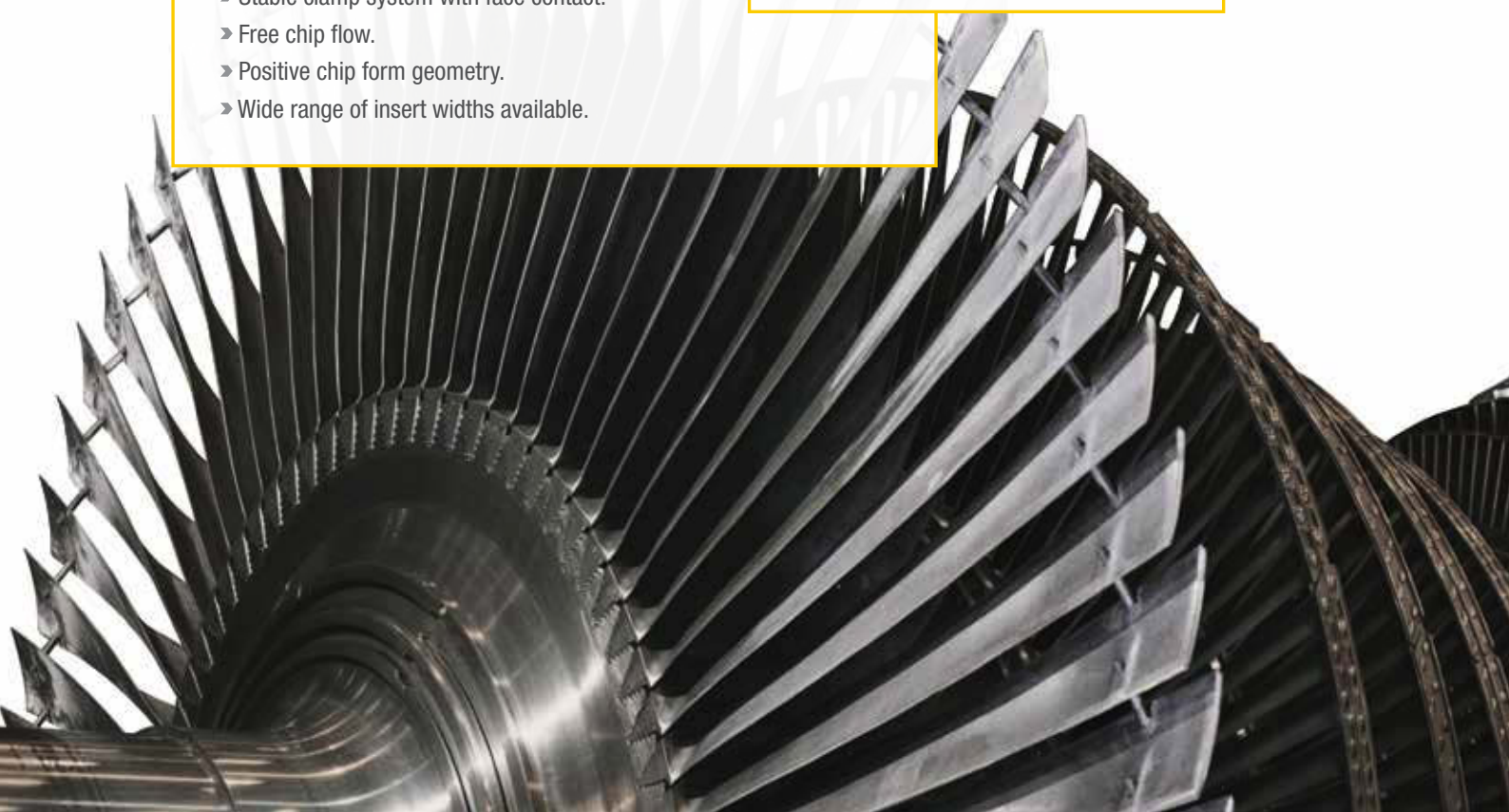



**INDEXABLE MILLING ROTOR SLOTS
BELL STYLE/SLOTING CUTTER**

Rough Machining Curved and Straight Blade Slots

- > Standard insert platform.
- > Full depth near-net profile.
- > High process reliability.

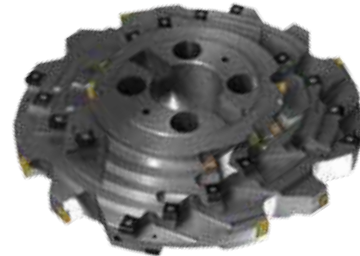

SOLID END MILLING

FIR TREE PROFILE ROUGHING



Conical Rougher

- > High metal removal.
- > Improved tool life.
- > Cutters can be reconditioned.

Profile Finisher

- > High accuracy profile finisher.
- > Improved tool life.
- > Cutters can be reconditioned.



DRILLING

**ROUGHING WITH
DRILL FIX™ DFR,™ DFT,™ DFS™**

- > Achieve up to 100% greater tool life at accelerated speeds.
- > Drill body features provide stability, coolant supply, and chip evacuation.
- > Wide range of applications and materials.
- > Predictable tool life and uniform wear.
- > Provides consistent surface finish.



FINE BORING

FINE-BORING HEAD

- > Highly efficient finishing tool.
- > High accuracy and surface quality.
- > Microadjustable cartridges.



BACK FACING

BACK-FACING HEAD

- > Modular tooling head for roughing and finishing.
- > Flexible system.
- > High reliability.

LARGE COMPONENT MACHINING

TURBINE CASING MACHINING Kennametal provides the solutions you need to achieve maximum productivity and profitability when machining turbine casings — the turbine component affected by long cycle times and complex operations. With innovative tools and an individual process plan, we can help to minimize tool changes and clamping, reduce downtime, and provide quality assurance.



ROUGH MILLING JOINT FACES

HEAVY-DUTY MEGA FACE MILL

- Stable insert for heavy cutting operation.
- Positive geometry in order to reduce cutting forces and aid low power consumption.
- Hardened shim for safe surface contact and cutter body protection.



SEMI-FINISHING JOINT FACES

KCMS™

- Easy change of cartridges with different insert styles and lead angles.
- Easy runout adjustment.
- Roughing and finishing solution with the same tool.



FINISH MILLING JOINT FACES

FIX-PERFECT™ FINISH MILLING CUTTER

- Adjustable inserts.
- Optimal axial runout.
- Steamtight faces.



CIRCULAR MILLING SLOTING CUTTER

- › Modular design with flexible cartridge system.
- › Designed for internal, heavy roughing operations at the casing.
- › High metal-removal rate.

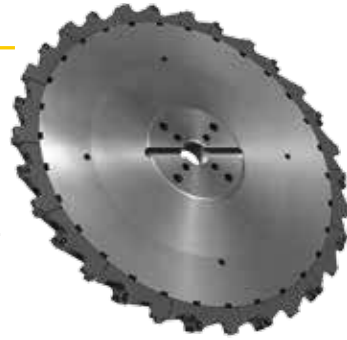

MODBORE™ TOOLING LARGE SCALE BRIDGE

- › Boring tool for boring and finishing large diameters.
- › Higher productivity and profitability.
- › More versatile and reliable.



ROUGH DRILLING DFS™, DFT™, KSEM PLUS™, HTS

- › Cost efficient.
- › High-performance drill solutions.



BACK FACING BACK COUNTER BORE CUTTER

- › Back boring, facing, and chamfering.
- › Quick change with manual self-locking head.
- › Standard and customized insert platforms.

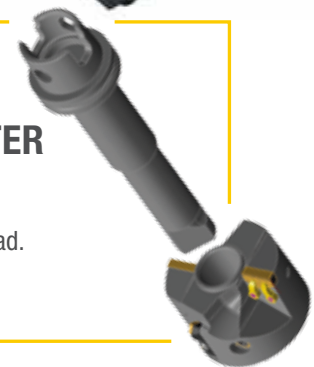

TAPS AND THREAD MILLS TMS THREAD MILLING SYSTEM

- › Higher strength and wider range of applications than carbide taps.
- › Higher tapping speed capability and longer tool life than conventional HSS-E taps.
- › High-quality internal and external threading on 3-axis CNC machines.
- › Capable of easily cutting most difficult materials up to 63 HRC.



LARGE COMPONENT MACHINING

TURBINE BLADE MACHINING Kennametal offers both standard and customized tooling solutions to cost effectively machine near-net shape blades, and blade root and air foil forms. Utilizing indexable carbide inserts, solid carbide end mills, and ceramic indexable insert cutters, Kennametal offers the expertise of a global supplier with products that provide maximum productivity on difficult-to-machine materials common in energy turbine components. A wide range of proven tooling solutions provides manufacturing flexibility and down time reduction.



ROUGH MILLING

DODEKA™

- › Universal 45° lead cutter for all face and rough interpolation operations.
- › Positive rakes enable high feed rates at given spindle power.
- › Lowest possible insert cost with long tool life and 12 cutting edges per insert.



RODEKA™

- › Double-sided insert with up to 12 cutting edges for a more productive cutting process.
- › Unique anti-rotation feature for excellent stability with higher feed rates and cutting forces.
- › Screw-on, end mill, and shell mill cutters with internal coolant.



MILL 1™

- › Aggressive ramping rates, high RPM capabilities, and a superior surface finish — time after time.
- › Varying axial depth of cut, meeting the challenges of a wide range of applications.
- › Helical solutions are also available.



ROUGH MILLING

HARVI II™

- › Unique 43° helix angle and innovative core shape enable maximum axial cutting depth.
- › AlTiN coating prolongs tool life and improves the surface finish.
- › Unequal flute spacing improves feed rate in corner radii operation versus conventional cutters.



SEMI-FINISHING

BALL NOSE

- › Innovative core shape.
- › Less vibration.
- › Maximize axial depth of cut.
- › Better surface finish and tool life.



FINISHING

MULTIFLUTE

- › High-speed cutter for turbine blade finishing.
- › Standardized corner radius.
- › New Beyond™ grade platforms.

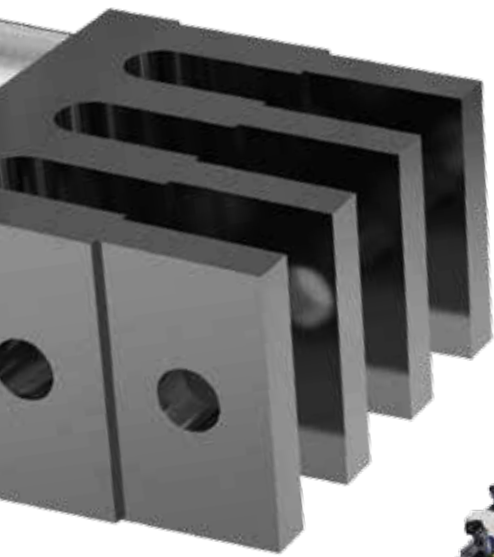

FINISHING

HARVI II LONG

- › Covers 3 x D and 5 x D lengths of cut as well as multiple corner radii available from stock.
- › Excellent for thin wall semi-finish and finishing operations.
- › Improved feed rate in corner radii operation versus conventional cutters.



ROUGH MILLING

**FIR TREE PROFILE
BLADE ROOT**

- › Standard insert program.
- › Near-net profile.
- › High productivity.



FINISH MILLING

**FIR TREE PROFILE
BLADE ROOT**

- › Brazed carbide solution.
- › Monolithic design.
- › High accuracy and tool life.

LARGE COMPONENT MACHINING

ELECTRICAL ROTOR MACHINING Whether you're machining coil, vent, wedge, or flex slots, Kennametal has the innovative tool concepts to ensure your electrical rotor machining is reliable and productive.



ROUGH & FINISH MILLING COIL-SLOT MILLING CUTTER

- › Flexible cartridge design.
- › Roughing and finishing in one pass.
- › High productivity.



FLEX SLOT MILLING CUSTOMIZED SOLUTIONS FLEX SLOTTING CUTTERS

- › Modular cutter design.
- › For slot and circular milling.
- › Standard ISO inserts.

WEDGE SLOT MILLING INDEXABLE END MILL

- › Monolithic design for extra rigidity.
- › Machining profile in one pass.



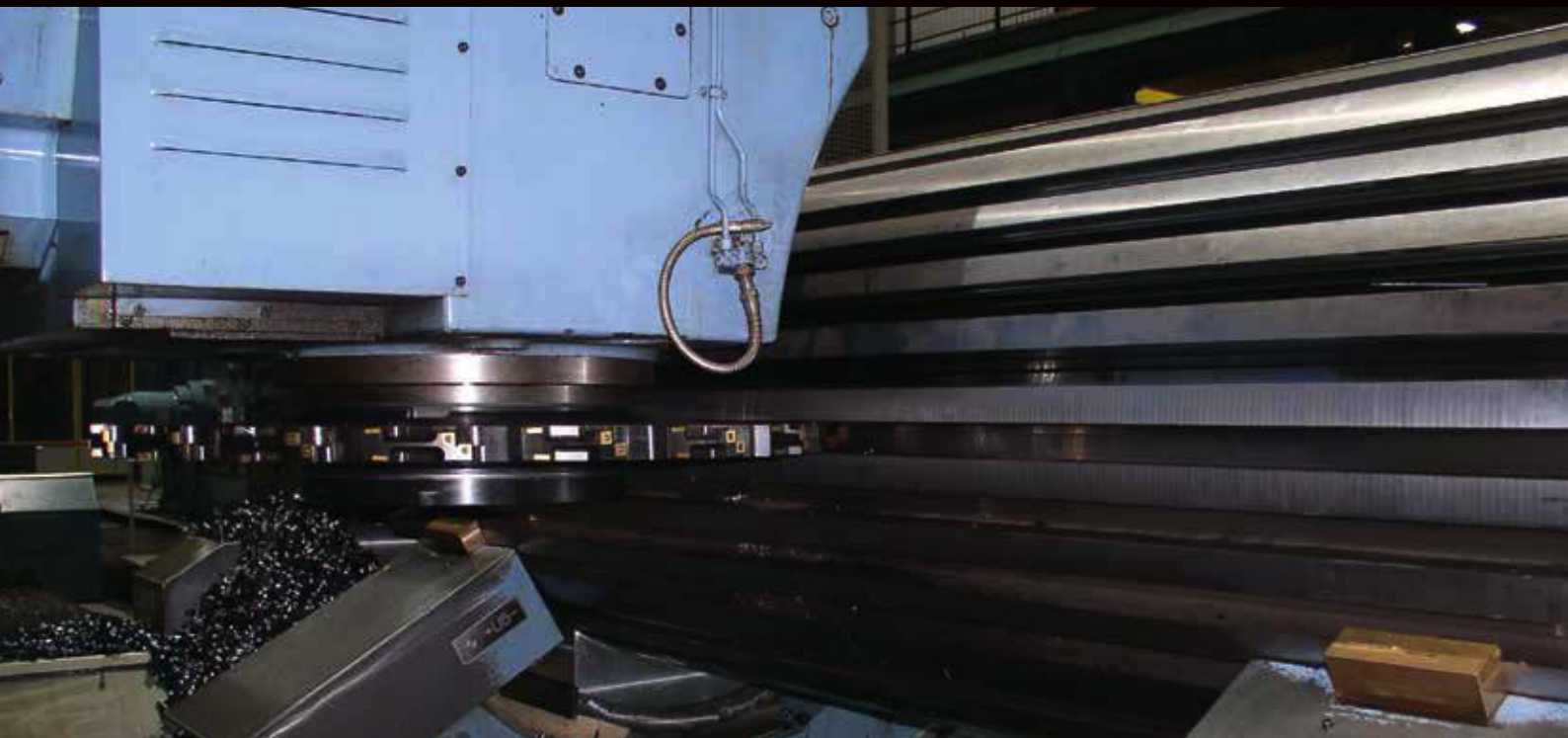

**DID YOU
KNOW** 

Kennametal's new strategy for finger-root blade milling saves you time, money, and the use of specialized tools. Now, CAM-data, complete tool set, and tool reconditioning are packaged together, enabling complex turbine blade milling operations in only one clamping operation. Before, individual milling sets and at least two clamping operations were required for the wide variety of root profiles. Kennametal's new standard, pre-drilled finger-root profiles enable the machining of slots in very short times and significantly reduce the cost per blade.

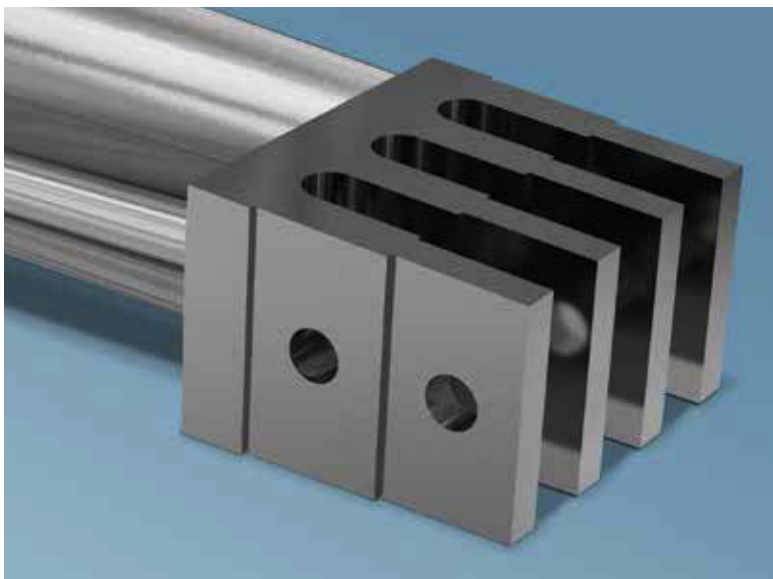

RENEWABLE ENERGY

WIND TURBINE Manufacturers of wind turbines throughout the world face business challenges every day and seek solutions for more capacity, higher productivity, and better quality. Whether you need to mill a tower segment, machine a blade, or turn a shaft, Kennametal has the manufacturing solutions to improve your wind energy processes.

Rely on Kennametal's milling portfolio for rough and finish gear milling of one- or multi-start indexable hobs and 6–40mm (1/4–1-1/2") module gears. Proven carbide grades, together with up to eight indexes per insert, enable the lowest tooling cost. Our innovative cutter designs enable advanced cutting, even under less-than-stable conditions. Kennametal gear specialists are available to help determine the optimum tool and process.



HOBBING

GEAR HOB

- › Most productive tool for external gears with higher number of teeth.
- › Module 6–40mm (1/4–1-1/2") as one and two start hobs.
- › Simple, modular design; operator-friendly insert changes.
- › Positive insert geometries available to reduce cutting forces.
- › vc: 120–160 m/min (397–525 SFM); f: 4mm (1/4") per gear revolution in 18CrNiMo.



TOWER SEGMENTS

Kennametal KSEM™ and KSEM PLUS™ modular drills have set the standard in the manufacturing of components including tower segments, pitch bearings, hubs, housings, and frames. KSEM drills double the metal removal rate compared with older tools. In less than 30 seconds, you'll drill a 39mm hole to 175mm DOC (1-1/2" x 6-7/8") into 42CrMo₄ steel.



MAIN SHAFT

Kennametal provides industry-leading turning technology. The new Beyond™ platform is designed to increase metal removal rates and extend tool life, up to two times in the alloy steels used in the wind industry. Kennametal HTS drills are a proven modular platform up to 450mm (17-3/4") diameter and up to 3m (10 ft) in length, and possess the capabilities to address the extremely demanding holemaking needs required for main shaft machining.



ROTOR BLADES

These remarkably long components range from 13–60m (40–200 ft). Kennametal DFT™ and DFS™ drills are equipped with polycrystalline diamond inserts that allow high cutting speeds and long tool life.

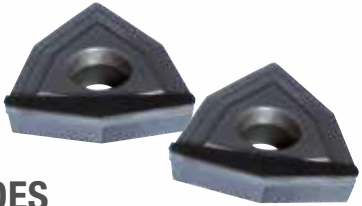

MILLING

GEAR GASHER

- > Most productive tool for external gears with lower number of teeth.
- > Module 6–40mm (1/4–1-1/2"), roughing and finishing cutters.
- > Lowest cost per piece by using inserts with multiple (up to eight) indexes.
- > Positive insert geometries available to reduce cutting forces.
- > Roughing; vc: 140 m/min (450 SFM); vf: 480 mm/min in 42CrMo₄
- > Finishing; vc: 180 m/min (600 SFM); vf: 2.750 mm/min in 42CrMo₄



RENEWABLE ENERGY

WIND TURBINE Contemporary wind turbines have much larger housings and gearbox components to accommodate ever-increasing power generation capacity. These larger, more sophisticated cast iron designs require high-precision machining, especially in boring operations. To achieve this accuracy, Kennametal offers fine-boring units made from high-strength aluminum that allows for both coarse and fine adjustment.

Using conventional tooling, the giant cast iron rotor hub can consume more than 20 hours of processing time. With Kennametal's highly productive tooling solutions, you can be assured to achieve the shortest cutting times with the maximum flexibility to perform multiple operations without tool changes.



TAPPING

SPIRAL FLUTE TAP

- › M36 x 4 HSG 5FL 15° spiral-flute tap with TIN+CRN/C coating.
- › Broad range of standard and custom design capabilities.
- › Proprietary coating technology for steel, cast iron, and non-ferrous materials.
- › vc: 50–60 m/min (160–200 SFM).

BORING

KM63TS TUNABLE BARS

- › Designed for large length-to-diameter boring applications.
- › Provides two to three times the dynamic stiffness compared to competing products.
- › Reduce tooling inventory by utilizing the ISO standard and KM™ Quick Change connection.
- › Pre-tuned, allows for finite adjustments.

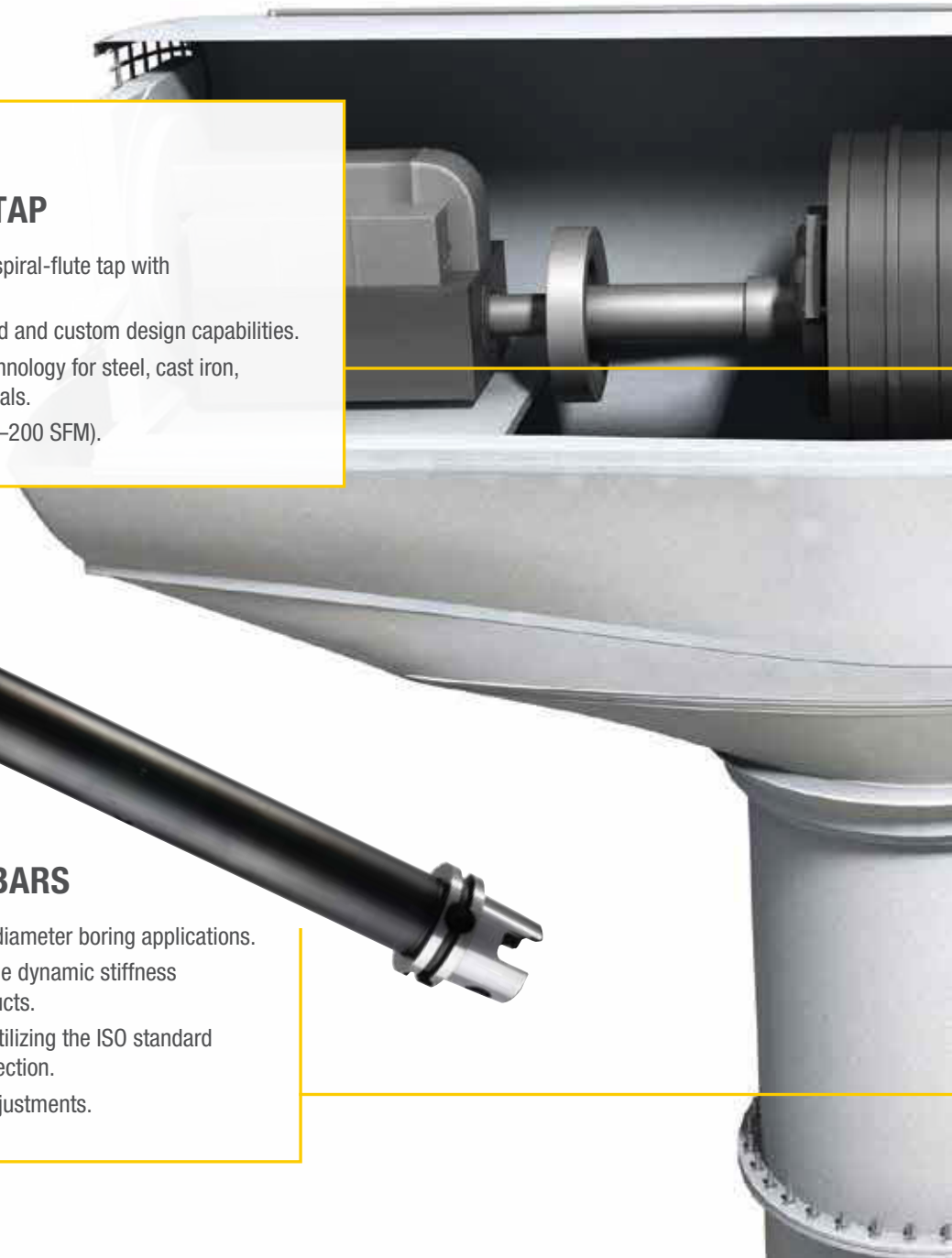

FINE BORING

ROMICRON™ BRIDGE TOOL

- › Up to 4m (12 ft) in diameter.
- › Through coarse adjustment, one tool for different diameters.
- › High-strength aluminium body, balanced by design.
- › Standard Romicon™ cartridges for reliable, indexable adjustment by micron.
- › Carbide inserts with high positive geometry and sharp cutting edges for highest precision and tool life.
- › vc: 200–250 m/min (650–820 SFM) f: 0,12–0,15 mm/rev in GGG40.



FACE AND INTERPOLATION MILLING

DODEKA™

- › Universal 45° lead cutter for all face and rough interpolation operations.
- › Positive rakes allow high feed rates at given spindle power.
- › Inserts with big corner radius recommended (e.g., R 4,3) for better surface finish.
- › Lowest possible insert cost with long tool life and 12 indexes per insert.
- › Broad insert range with strong cutting edge as well as wiper.
- › Reduction of cycle time by advanced cutting parameters.
- › vc: 200–250 m/min (650–820 SFM); vf: 2–11 m/min (6–36 ft/min).



90° INTERPOLATION MILLING

FIX-PERFECT™

- › One cutter for all 90° interpolation milling operations requiring minimum tool changes.
- › Remarkable cutter design with proven performance.
- › Excellent tool life with lowest carbide cost by using up to eight effective cutting edges.
- › Wiper inserts available for fine finishing.
- › Reduction of cycle time by advanced cutting parameters.
- › vc: 200–250 m/min (650–820 SFM); vf: 6 m/min (20 ft/min).



RENEWABLE ENERGY

NUCLEAR ENERGY Kennametal provides customized solutions for the nuclear energy industry by addressing a wide variety of standard and customer-specific applications. With a proven track record of reliable performance, Kennametal products deliver maximum consistency and dependability for demanding nuclear power plant environments.



SOLAR ENERGY It has its advantages: It is clean, abundant, and renewable. However, the solar industry faces the challenge of improving efficiencies and expanding operations to grow into a viable alternative energy source to existing fossil fuels. Whether you need material or process advancements, Kennametal has the manufacturing solutions that will bring costs into a competitive range for solar energy development.



WASTE TO ENERGY Taking part in waste to energy presents a way for municipal solid waste facilities to provide clean energy for surrounding communities. Kennametal offers these facilities a way to keep operations running smoothly by extending the life of boiler components to ensure premium optimization of boiler efficiency.



SEALS

- › Proven performance in rotating seals for demanding nuclear power applications.
- › Meets stringent quality and regulatory standards for nuclear regulations.
- › Established grade offering used in nuclear application for over 40 years.
- › Vertically integrated manufacturing for maximum process control.



BORON NITRIDE SHAPES AND COMPOSITES

Ideally Suited for Critical Applications Found in the Manufacturing of Solar Cells:

- › Inert.
- › High temperature capability (up to 2000 °C).
- › High dielectric strength.
- › High thermal conductivity.
- › Not wetted by most molten metals.
- › Low thermal expansion.



BOILER TUBES

- › High coefficient of heat transfer.
- › Severe thermal shock resistance.
- › Extended, predictable tube life due to linear wear.
- › Erosion protection for consistent thickness and density.
- › Fully protects pendants, U-bends, and complex shapes.



METALCUTTING CAPABILITIES

Metalcutting has been our expertise for more than 70 years. From drilling and milling to turning and tapping, Kennametal never stops engineering the industry's best metalworking solutions to enhance your overall productivity — even for the most challenging applications — because helping your business grow and succeed is what our business is all about.



TURNING

FIX-PERFECT™

- › Ideal for conditions where workpiece and machine stability issues are common.
- › Excellent chip flow when machining steel, cast iron, and stainless steel.



BEYOND™ INSERTS

- › Superior productivity.
- › Exceptional versatility.
- › Predictable and dependable tool life.
- › PVD grades provide excellent wear resistance.
- › Beyond BLAST™ inserts deliver coolant directly to the cutting edge.



BOLT ON HEADS & BORING ADAPTERS

- › Quick-change connection reduces setup time.
- › Fast and easy cutting tool change over.
- › Affordable solution for multiple boring applications.
- › Available in popular geometries for steel and carbide bars.



TURNING, GROOVING, & CUT-OFF

A4™ GROOVING AND TURNING

- › Enables faster cycle times.
- › Use for O.D. and I.D. applications.
- › Unsurpassed grooving and side-turning stability.
- › Precise insert positioning ensures accurate cuts.
- › Rigid clamping securely locks insert in place even for the toughest cuts.



TOP NOTCH™

- › Designed to cut a variety of materials.
- › Use for O.D. and I.D. applications.
- › Excellent chip evacuation.
- › Rigid clamping securely locks insert in place even for the toughest cuts.



A2™ CUT-OFF

- › Top and bottom V-prisms enable higher clamping force, preventing insert movement even at high feed rates.
- › Molded-in chipbreaker ramp extends blade life by directing chips away from the blade.
- › Positive rake cutting action and PVD coatings result in superior tool life and chip control.



MILLING

MEGA™

- Offered in several lead angle and size combinations.
- Maximum axial depth of cut up to 25,4mm (1").
- Cutter body protection with carbide anvil.



DODEKA™

- Universal 45° lead cutter for all face and rough interpolation operations.
- Positive rakes enable high feed rates at given spindle power.
- Lowest possible insert cost with long tool life and 12 cutting edges per insert.



MILL 1™

- Aggressive ramping rates, high RPM capabilities, and a superior surface finish — time after time.
- Meeting the challenges of a wide range of applications.
- Helical solutions are also available.



SOLID END MILLING

HARVI™ LINE SOLID CARBIDE END MILLS

- Outstanding performance in stainless steel, titanium, INCONEL®, and other high-temperature alloys and steels.
- Increased metal removal rates in roughing and finishing operations.
- Excellent performance in both slotting and side-milling operations.



BEYOND™ GRADE KCPM15™

- Increases tool life and productivity by up to 30% in stainless steel.
- Precise, high-quality edge preparation for improved coating adhesion and edge stability.
- Improved chip control.



GOMILL™ LINE

- Made specifically for short-length-of-cut applications in a wide range of materials.
- Ideal for slotting and side milling up to 1 x D.
- Ball nose, chamfer, and sharp corner styles are available.

METALCUTTING CAPABILITIES



DRILLING

KENNA PERFECT™ SE-HP DRILLS

- › Ideal for use in thin-walled applications.
- › Provides up to 20% lower thrust versus other sculptured-edge (SE) drills.
- › Positive chisel edge promotes soft start and cutting from center.
- › Engineered for heat-resistant alloys, titanium, and titanium alloy materials.
- › Drills can be factory reconditioned by Kennametal to original specifications.



KENTIP™ DRILLS

- › Offer performance usually achieved with solid carbide drills.
- › Use for applications from 8–25,99mm (.314–1.023") up to 8 x D.
- › Wide range available for steel, stainless steel, cast iron, and ductile iron applications.
- › Easy insert changes with unique locking method that requires no screws or clamps.
- › Disposable inserts avoid reconditioning time and costs.
- › Same performance insert to insert.



GROOVING SYSTEM FOR HEAT EXCHANGER PLATES

- › Available in end mill or self feed styles.
- › Internal coolant for higher tool life and better chip formation.
- › Covers TEMA standard sizes 19,25mm (.758") and 25,68mm (1.011").
- › Productive solution for shallow or deep hole applications on a wide range of machines.



HOLE FINISHING

ROMICRON™ SVU HEADS

- › Boring head sizes from 71–111mm (SVU65) and 10–213mm (SVU92).
- › Radial stroke of 2,5mm (SVU65) and 3,5mm (SVU92).
- › Adjustment accuracy is 1µm on the radius, with large diameter range due to boring bars and cartridges.
- › Built-in balancing ring with enabled coolant pressure of 20 bar at 6000 RPM.



RIQ™ QUATTRO CUT™ AND RIR™ PADDED REAMER INSERTS

- › Predictable tool life/uniform wear.
- › RIQ padded reamers reduce setup time.
- › Make use of full four edges even in PCD or PCBN when using RIQ inserts.
- › Achieve consistent surface finish.



TOOLING SYSTEMS

KM™ TUNABLE BARS

- › Combine the proven advantages of the KM Quick Change system with our industry-leading tunable boring bar technology.
- › Ideal solution for poor surface quality and high scrap rates caused by chattering and vibrations.
- › Bars are delivered pretuned for 6:1 and 8:1 L/D.
- › Standard bolt-on head cutting units are available in a wide selection.



KM80TS™

- › Improve overall machining efficiency by up to 60%.
- › Reduce downtime with quick tool changes and setups.
- › Highest tangential load-carrying capability on the market.
- › Exclusive three-surface taper contact design for highly accurate tooling.
- › Everything you need is in one complete tooling package.



TAPPING

T620 LH SPIRAL FLUTE

- › For through hole tapping.
- › Push chips ahead, enabling free tapping of long chipping materials.
- › Form D plug chamfer.



T630 RH SPIRAL FLUTE

- › For blind hole tapping.
- › Form C semi-bottoming chamfer.



T640 STRAIGHT FLUTE

- › For through and blind hole tapping in cast iron and cast aluminum.
- › Form C semi-bottoming chamfer.

BEST PRACTICES

Kennametal's intimate understanding of the energy marketplace — including customer processes and applications — allows us to proactively address production and sustainability concerns with solutions tailored to your needs. We deliver superior value because we listen closely to you, our customer, and innovate based on your feedback. Our goal is to help you be more competitive — both at home and on a global scale.

BEST PRACTICES IN PRODUCTIVITY

As your trusted partner for optimized production, Kennametal offers customers a unique commitment to research and development excellence, leading to continued delivery of highly innovative ways to enhance your productivity. Certification to ISO 9001, QS 9000 TES, and VDA 6.4 guarantees the highest possible quality standards.

BEST PERFORMANCE, LESS ENVIRONMENTAL IMPACT

With technology, we can do both. Kennametal helps customers focus on the root causes of unsustainable behavior in highly complex manufacturing systems, while at the same time improving cost structure, quality, and performance. In addition to offering the latest in metalcutting tools and technology, our Advanced Engineering team will analyze your existing production processes and help you identify new methods to improve your overall performance.

LESS ENVIRONMENTAL IMPACT

To learn more about our sustainable solutions for the energy industry, contact your Kennametal Representative or Authorized Kennametal Distributor today.

ADVANCED MATERIALS

For more than 70 years, Kennametal has been recognized as the leader in advanced material solutions by engineering and manufacturing customized protective systems for the world's harshest environments. We strive to develop advanced engineered solutions that fit your needs to give you the best solution for your application — enabling Kennametal to stay ahead of technology's cutting edge.

KENNAMETAL DELIVERS

We offer our customers outstanding performance and value in everything we do. Our world-class manufacturing process, development, and implementation capabilities allow us to handle everything from the simplest, one-piece part order to complete solutions for harsh wear, impact, and corrosive environments — ultimately prolonging service life, improving performance, and reducing your costs.

OUR GLOBAL COMMITMENT

The energy segment is a globally diverse industry. Customer operations are located throughout the world, and Kennametal is committed to coordinating our global resources, engineering innovation, and advanced material expertise to provide you with the support that can optimize your entire process, not just portions of it. Let our experts work with yours to find the solutions you need to be successful — wherever you may be located.

CUSTOMIZED PROTECTIVE SYSTEMS

To learn more about our advanced materials systems for the energy industry, contact your Kennametal Representative or Authorized Kennametal Distributor today.

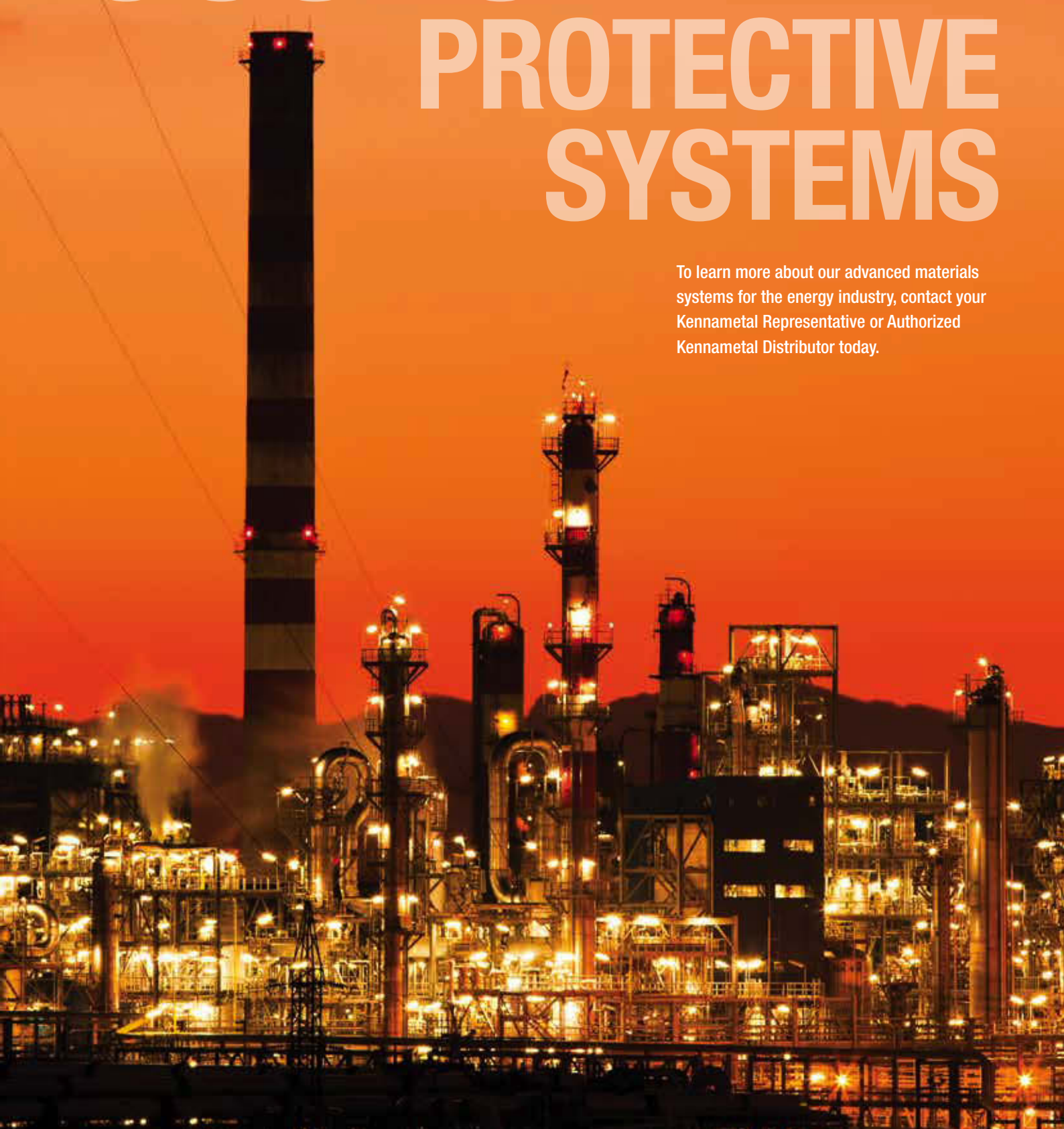

WEAR SOLUTIONS

Kennametal is the only company with access to the full spectrum of wear solutions to meet your specific needs. From solid ceramics and tungsten carbides, weld overlay, and brazed carbides, to abrasion-resistant steels and stainless steels, Kennametal has both the products and application expertise for your most demanding applications.

EXTENSIVE EXPERIENCE, TARGETED SOLUTIONS

Component wear occurs in many different ways and is often a combination of wear from more than one mechanism. Impact, adhesion, abrasion, erosion, surface fatigue, and corrosion can all play a role in your wear environment. Kennametal's broad experience in wear solutions, and range of products, enables us to not only diagnose your wear issue, but also find the most cost-effective solution for your application.

For high-wear/low-impact environments, solid tungsten carbide, Kennametal cladding, or welded carbide will perform best. In environments where wear is a combination of impact and abrasion, we have martensitic, steel-based product lines, including Tri-Braze™ and Tri-Braze Dura-Plus.™ In environments that combine temperature, corrosion, and abrasion, we have a variety of weld-based solutions, including chromium carbide, as well as abrasion-resistant stainless steels.



FOR THE MOST DEMANDING APPLICATIONS

To learn more about our wear solutions for the energy industry, contact your Kennametal Representative or Authorized Kennametal Distributor today.



SUSTAINABLE ENGINEERING

With decades of experience, Kennametal offers you some of the most effective opportunities for sustainable manufacturing in the industry using the synergies of superior engineering, leading technology, and tailor-made solutions. Our comprehensive range of products, local support, and excellent customer service make Kennametal your complete supplier of sustainable tooling solutions.

Successful project engineering requires planning, teamwork, and disciplined execution. Through our extensive experience in developing and implementing new project engineering strategies, Kennametal has pioneered a proven methodology to help you manufacture new products and bring them to market quickly. Service deliverables are carefully outlined and jointly agreed to before the project begins. We formally evaluate progress and results with you throughout the project through our stage-gate management system.

Kennametal can provide your engineering teams and machine tool builders with process engineering support, advanced metalcutting technologies, and project management expertise to help you achieve your sustainability goals. With our best-in-class process, you'll experience accelerated time-to-market, lower overall costs, and reduced risks to implement new technologies.

DID YOU KNOW

Kennametal has more than 700 highly trained, and innovative, research scientists and development engineers. They are creating new advanced materials for demanding applications and are designing proprietary components that deliver superior performance to our customers.



DISCOVERY AND PROPOSAL DEVELOPMENT

- › Review project needs with customer and/or machine tool builder.
- › Customer decision gate: Request proposal.

PROPOSAL PRESENTATION

- › Discuss how Kennametal can be of service.
- › Customer decision gate: Request proposal.

BUILD PROJECT PLAN

- › Clarify technical and commercial aspects of projects.
- › Develop engineering and project schedule.
- › Approve drawings.

PROJECT PLAN APPROVAL

- › Present drawings and confirm order.
- › Customer decision gate: Approve project plan and deliverables.

EXECUTION

- › Manufacturing.
- › Procurement.
- › Project management.
- › Assembly.
- › Pre-setting.
- › Balancing.
- › Inspection.
- › Shipping.
- › Training.
- › Run-off support.

ACCEPTANCE

- › Review performance versus contract.
- › Customer decision gate: Formal acceptance.

PRODUCTION RAMP-UP ASSISTANCE

- › Support program launch schedule by assistance in spare part and consumable procurement planning, and further process optimization.



PRECISION SURFACE MANAGEMENT

As a leader in precision surface management, Kennametal offers a wide range of solutions to meet your specific application needs. We work alongside our customers from the early stages of their projects all the way through the production process to improve functionality and increase performance. Kennametal has the products and the expertise to help support your short- and long-term endeavors.

LOOKING FORWARD

Kennametal always looks ahead in order to help our customers stay competitive. As energy costs continue to rise, Kennametal believes that it is important to produce more efficient units with equivalent or improved results. Kennametal delivers you first-class savings — saving you both energy and money. Our lab is constantly working to provide you with energy industry-specific medias to enhance the quality and productivity of your projects.

GLOBAL SUPPORT

At Kennametal, we have a strong focus on the customer. We have worked alongside numerous key players including our end users to develop a real understanding of the needs of the industry. Kennametal engineers will be with you every step of the way to improve flow rate, quality, productivity and efficiency. Kennametal will follow you across the globe to help you maximize your investment and prolong the life of your equipment.

GLOBAL CONTACTS

Visit www.kennametal.com for additional contact information for locations.

NORTH AMERICA

United States

General Sales: 800 446 7738
 FtMill.Service@kennametal.com
 Technical Support: 800 835 3668
 na-kmt.techsupport@kennametal.com

Kennametal Engineered Products Group
 866 374 3006
 k-rgrs.cs@kennametal.com

Kennametal Tricon Metals & Services
 800 633 6054
 k-brmg.information@kennametal.com

Kennametal Energy Mining & Construction
 800 458 3608
 mcs-na.service@kennametal.com

Kennametal Conforma Clad
 888 289 4590
 k-nalb.cs@kennametal.com

Canada

General Sales: 800 446 7738
 edmonton.service@kennametal.com
 Technical Support: 800 835 3668
 na-kmt.techsupport@kennametal.com

Mexico

General Sales: 001 888 402 4963
 k-mx.service@kennametal.com

CENTRAL/SOUTH AMERICA

Argentina

General Sales: +54 11 4719 0700
 buenos-aires.ventas@kennametal.com

Brazil

General Sales: +55 19 3936 9200
 bra.marketing@kennametal.com

Chile

General Sales: +56 2 2641177
 kennametalchile@kennametalchile.cl

CENTRAL/SOUTH AMERICA (CONT.)

El Salvador

General Sales: +503 2218 8096
 prometca@salnet.net

Venezuela

General Sales: +58 305 595 5175
 paxi@bellsouth.net

EUROPE

Austria

General Sales: +43 2236 379898
 brunn.sales@kennametal.com
 Technical Support: 0800 202873
 eu-kmt.techsupport@kennametal.com

Belgium

General Sales: +32 4 248 48 48
 liege.sales@kennametal.com
 Technical Support: 0800 80850
 eu-kmt.techsupport@kennametal.com

Czech Republic

Ricany-Jazlovice
 General Sales: 800 900 840
 k-prha.sales@kennametal.com

France

General Sales: +33 1 69 77 83 83
 info.fr@kennametal.com
 Technical Support: 0805 540 367
 eu-kmt.techsupport@kennametal.com

Germany

General Sales: +49 6172 737 0
 friedrichsdorf.service@kennametal.com
 Technical Support: 0800 0006651
 eu-kmt.techsupport@kennametal.com

Great Britain

General Sales: +44 1384 408060
 kingswinford.service@kennametal.com
 Technical Support: 0800 032 8339
 na-kmt.techsupport@kennametal.com

Hungary

General Sales: +36 96 618 158
 gyoer.sales@kennametal.com

EUROPE (CONT.)

Ireland

General Sales: +44 28 9084 9433

Italy

General Sales: +39 02 895 961
 milano.vendite@kennametal.com
 Technical Support: 800 916561
 eu-kmt.techsupport@kennametal.com

Luxembourg

General Sales: +32 4 248 48 48
 liege.sales@kennametal.com

Netherlands

General Sales: +31 26 384 48 50
 arnhem.information@kennametal.com
 Technical Support: 0800 0201130
 eu-kmt.techsupport@kennametal.com

Poland

General Sales: +48 61 6656501
 poznan.sales@kennametal.com
 Technical Support: 00800 4411887
 eu-kmt.techsupport@kennametal.com

Portugal

General Sales: +351 22 4119 400
 porto.service@kennametal.com

Russia

General Sales: +7 495 4115386
 system@kennametal.ru

Slovakia

General Sales: +421 42 444 0792
 dubnica.sales@kennametal.com

Spain

General Sales: +34 93 586 03 50
 barcelona.service@kennametal.com

Turkey

General Sales: +90 216 574 4780
 tr.information@kennametal.com

GLOBAL CONTACTS

EAST/ASIA PACIFIC

Australia

General Sales: +1 800 666 667
k-au.service@kennametal.com
Technical Support: +1 800 674 037
ap-kmt.techsupport@kennametal.com

Bahrain

General Sales: +971 0 5572371
info@passtech.co.uk

China

General Sales: +86 21 3860 8288
Technical Support: 400 889 2238

Dubai

General Sales: +971 0 5572371
info@passtech.co.uk

India

General Sales: +91 080 22198444
+91 080 43281444
bangalore.information@kennametal.com

Indonesia

General Sales: +65 6 2659222
k-sg.sales@kennametal.com
Technical Support: 1800 6221031

Israel

General Sales: +97 23 558 1313
arnold1@inter.net.il
Technical Support: 1809 449889
na-kmt.techsupport@kennametal.com

Japan

General Sales: +813 3820 2855
Technical Support: +813 3820 2855
ap-kmt.techsupport@kennametal.com

EAST/ASIA PACIFIC (CONT.)

Korea

General Sales: +82 2 2109 6100
Technical Support: +080 728 0880

Kuwait

General Sales: +971 0 5572371
info@passtech.co.uk

Malaysia

General Sales: +6 03 5569 9080
Technical Support: 1800812990

New Zealand

General Sales: 0800 536626
k-nz.service@kennametal.com
Technical Support: 0800 450941
ap-kmt.techsupport@kennametal.com

Pakistan

General Sales: +92 21 2465305
itsystem@brain.net.pk

Singapore*

General Sales: +65 6 2659222
k-sg.sales@kennametal.com
Technical Support: 1800 6221031
*Vietnam and Philippines individuals
should contact the Singapore office.

Taiwan

General Sales: +886 4 2350 1920
taiwan.service@kennametal.com
Technical Support: 0800 666 197

Thailand

General Sales: +66 2 642 3455
Technical Support: 18004417820

AFRICA

Egypt

General Sales: +20 2 263 9828
gafa@link.net

South Africa

General Sales: +27 11 397 3540
kempton.service@kennametal.com



PRODUCTIVE INNOVATIVE ADVANCED

OUR MISSION

Kennametal delivers productivity to customers seeking peak performance in demanding environments by providing innovative customized and standard wear-resistant solutions, enabled through our advanced materials sciences, application knowledge, and commitment to a sustainable environment.

ENERGY

WORLD HEADQUARTERS

Kennametal Inc.

1600 Technology Way

Latrobe, PA 15650

USA

Tel: 800 446 7738 (United States and Canada)

E-mail: ftmill.service@kennametal.com

EUROPEAN HEADQUARTERS

Kennametal Europe GmbH

Rheingoldstrasse 50

CH 8212 Neuhausen am Rheinfall

Switzerland

Tel: +41 52 6750 100

E-mail: neuhausen.info@kennametal.com

ASIA-PACIFIC HEADQUARTERS

Kennametal Singapore Pte. Ltd.

ICON@IBP #01-02/03/05

3A International Business Park

Singapore 609935

Tel: +65 6265 9222

E-mail: k-sg.sales@kennametal.com

INDIA HEADQUARTERS

Kennametal India Limited

CIN: L27109KA1964PLC001546

8/9th Mile, Tumkur Road

Bangalore - 560 073

Tel: +91 080 22198444/ +91 080 43281444

E-mail: bangalore.information@kennametal.com

www.kennametal.com

