



WIND ENERGY

SUSTAINABLE SOLUTIONS

Manufacturing and Farming Wind Energy for a New Generation





WIND ENERGY

Kennametal leads the way with innovation, engineering, and service in standard and custom tooling.

YOUR COMPONENTS MACHINED IN RECORD TIME

With the right tool and the right know-how, your speed, accuracy, and output can be improved tremendously. As your trusted partner for optimized production, Kennametal offers an unprecedented commitment to research and development excellence, leading to highly innovative ways to enhance your productivity. Certification to ISO 9001, QS 9000 TES, and VDA 6.4 guarantees the highest possible quality standards.

ENVIRONMENTAL SUSTAINABILITY

At Kennametal, we are deeply committed to designing and manufacturing environmentally responsible products that deliver high performance and proven value. With decades of experience in tooling and manufacturing, the synergies of superior engineering, leading technology, and customized solutions offer customers some of the most effective opportunities for sustainable manufacturing in the industry. Our comprehensive range of products, local support, and excellent customer service make Kennametal your complete supplier of sustainable wind turbine generator manufacturing solutions.



TOWER SEGMENTS

Wind turbine manufacturers throughout the world face business challenges every day and seek solutions for more capacity, higher productivity, and better quality. When it comes to tower segments, manufacturers need to produce high-quality chamfer welds with components spaced and aligned perfectly. Furthermore, capacity constraints require dramatic reductions in manual operations and routine processing times. That's where Kennametal can assist.

Kennametal KSEM™ and KSEM PLUS™ modular drills have set new standards in the manufacturing of components including tower segments, pitch bearings, hubs, housings, and frames. KSEM drills double the metal removal rate compared with older tools. In less than 30 seconds, you can drill a 39mm hole to 175mm DOC (1½" x 6⅞") deep into 42CrMo4 steel. With the KSEM and KSEM PLUS drills, you'll add hundreds of hours to your machine capacity each year.

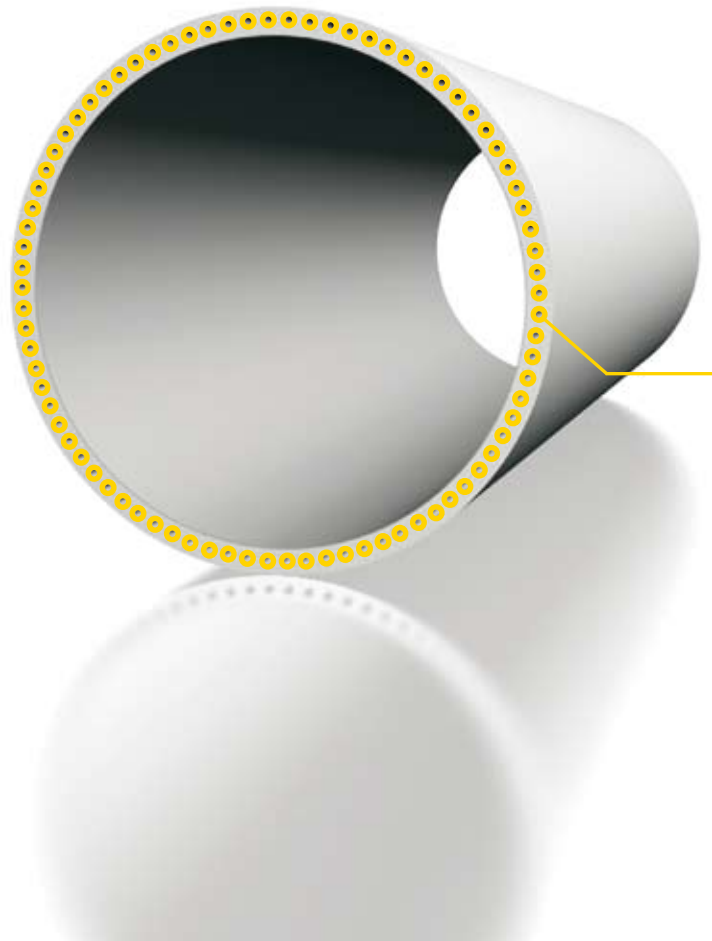

**CLICK
AND SEE**



visit www.kennametal.com
and explore Kennametal
tools and custom solutions.



MILLING OF WELDING CHAMFERS

WELDING MILLING CUTTER

- › Improve cycle time to machine 16m (52½ ft) from 120 minutes to 25 minutes.
- › Minimum inventory, maximum variety.
- › 75 possible variations using only 2 styles of inserts.
- › $V_c = 160 \text{ m/min (525 sfm)}$
- › $V_f = 700\text{mm/min (2,297 sfm)}$

DRILLING

KSEM PLUS™

- › Double the metal removal rate.
- › Replaces conventional indexable drilling operations.
- › Modular design for easiest handling and setup.
- › Diameter range of 32mm to 70mm (1½" to 2¾").

ROTOR HUB

Using conventional tooling, the giant cast iron rotor hub can consume more than 20 hours of processing time. But with highly productive tooling solutions from Kennametal, you can be assured the shortest cutting times with the maximum flexibility to perform multiple operations without tool changes.

For rough milling of faces and bores with helical interpolation, Kennametal milling cutters and inserts offer progressive feed rates of 6–12 m/min (20–40 ft/min). Each minute of reduced cycle time will improve throughput, offsetting the cost of additional capacity.

In addition to rotor hubs, Kennametal's advanced technology can be applied to a variety of components, including nodular or grey cast iron housings, gearboxes, planet carriers, and frames. Other advanced tools such as Kennametal KSEM™, KSEM Plus™, and HTS drills and HSS taps should be used on rotor hubs for maximum efficiency.





DID YOU KNOW



Longer tool life is a hallmark of sustainable production.

Kennametal utilizes sub-micron grain sized grades of tungsten carbide to provide the maximum wear life when compacting abrasive materials.



90° INTERPOLATION MILLING

FIX PERFECT

- › One cutter for all 90° interpolation milling operations requiring minimum tool changes.
- › Remarkable cutter design with proven performance.
- › Excellent tool life with lowest carbide cost by using up to 8 effective cutting edges.
- › Wiper inserts available for fine finishing.
- › Reduction of cycle time by advanced cutting parameters.
- › $V_c = 200\text{--}250$ m/min (650–820 ft/min)
- › $V_f = 6$ m/min (20 ft/min)



FACE AND INTERPOLATION MILLING

DODEKA™

- › Universal 45° lead cutter for all face and rough interpolation operations.
- › Positive rakes enable high-feed rates at given spindle power.
- › Inserts with big corner radius recommended (e.g., R 4,3) for better surface finish.
- › Lowest possible insert cost with long tool life and 12 cutting edges per insert.
- › Broad insert range with strong cutting edge as well as wiper.
- › Reduction of cycle time by advanced cutting parameters.
- › $V_c = 200\text{--}250$ m/min (650–820 ft/min)
- › $V_f = 2\text{--}11$ m/min (6–36 ft/min)



ROTOR BLADES



These remarkably long components range from 13–60 m (40–200 ft). In addition to material handling constraints, rotor blades require 5 to 6 hours of machining time with changeover requirements up to 2 hours.

Kennametal's legendary experience in high-speed machining for the aerospace industry has driven the development of drills for the wind turbine blades made from composite fibers. Kennametal DFT™ and DFS™ drills are equipped with polycrystalline diamond inserts for high cutting speeds and long tool life.

**DID YOU
KNOW**



Kennametal provides product solutions that withstand harsh wear, impact, and corrosive environments to prolong tool life and reduce costs. We offer custom-made preformed, semi-finished, and finished products to meet your needs.

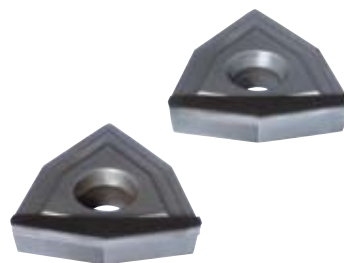

➔ **HOLEMAKING**

**DRILL FIX DFT™ & DFS™
WITH PCD INSERTS**

- Improved cycle times by piloting and drilling on a single operation.
- PCD-tipped carbide inserts for long tool life.
- High-speed cutting.
- In-stock system with standard tooling to replace custom gun-drill applications.



HOUSING

Contemporary wind turbines have much larger housings and gearbox components to accommodate ever-increasing power generation capacity. These larger, more sophisticated cast iron designs require high-precision machining, especially in boring operations. A 5mW turbine, for example, requires a 3m diameter bore hole with an H7 tolerance.

To achieve this accuracy, Kennametal bridge tools with standard Romicon® fineboring units are your first choice. The tools are made from high-strength aluminum and allow for both coarse and fine adjustment. For fine adjustment, the Romicon units are unsurpassed in precision, reliability, adjustment speed, and operator friendliness. The number of measuring cycles and re-adjustments is minimal. Using a reference cut, the final diameter can be easily and reliably set within microns inside the machine.





FINEBORING

ROMICRON® BRIDGE TOOL

- › Up to 4m (12 ft) in diameter.
- › Through coarse adjustment, one tool for different diameters.
- › High-strength aluminum body, balanced by design.
- › Standard Romicon cartridges for reliable, indexable adjustment by micron.
- › Carbide inserts with high-positive geometry and sharp cutting edges for highest precision and tool life.
- › $V_c = 200\text{--}250$ m/min (650–820 ft/min)
- › $f = 0,12\text{--}0,15$ mm/rev in GGG40



TAPPING

GUN AND SPIRAL FLUTE TAP

- › M36x4 HSG 5FL 15° spiral flute tap with TIN+CR/C coating.
- › Broad range of standard and custom design capabilities.
- › Proprietary coating technology for steel, cast iron, and non-ferrous materials.
- › $V_c = 50\text{--}60$ m/min (160–200 ft/min)



BORING

KM63TS TUNABLE BARS

- › Designed for large length-to-diameter boring applications.
- › Provides 2–3x the dynamic stiffness over competing products.
- › Reduce tooling inventory by utilizing ISO standard KM™ Quick-Change connection.
- › Pre-tuned, enables finite adjustments.

BEARINGS AND GEARS

For the pitch drives of rotor blades and nacelle, large compact bearings with internal or external gears are needed. Producing these components requires turning, holemaking, and gear milling. With Beyond™ turning grades, KSEM PLUS™ drills, and internal and external gear milling for roughing and finishing, ensure the minimum cycle time and cost without sacrificing superior quality.

Rely on Kennametal's milling portfolio for rough and finish gear milling of one- or multi-start indexable hobs and 6mm module and 40mm module gears. Proven carbide grades, together with up to 8 indexes per insert, enable the lowest tooling cost. Our innovative cutter designs enable advanced cutting, even under less-than-stable conditions. Kennametal gear specialists are available to help you determine the optimum tool and process.



**CLICK
AND SEE** 

visit www.kennametal.com
and explore Kennametal
tools and custom solutions.

HOBBING

GEAR HOB

- › Most productive tool for external gears with higher number of teeth.
- › Module 6mm to 40mm ($\frac{1}{4}$ " to $1\frac{1}{2}$ "") as one- and two-start hobs.
- › Simple, modular design; operator-friendly insert change.
- › Positive insert geometries available to reduce cutting forces.
- › VC = 120 to 160 m/min (397 to 525 ft/min),
f = 4mm ($\frac{1}{6}$ "") per gear revolution
in 18CrNiMo.

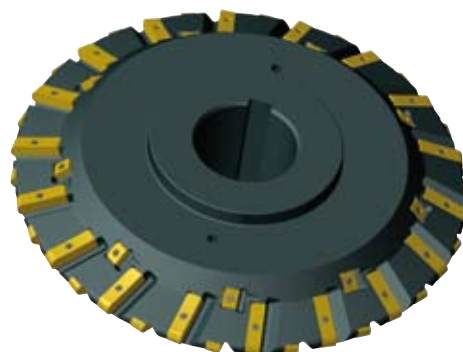

MILLING

GEAR GASHER

- › Most productive tool for external gears with lower number of teeth and for internal gears.
- › Module 6mm to 40mm, roughing and finishing cutters.
- › Lowest cost per piece from inserts with multiple (up to 8) cutting edges.
- › Positive insert geometries reduce cutting forces.
- › Roughing: VC = 140 m/min (450 ft/min) and Vf = 480mm/min in 42CrMo4.
- › Finishing: VC = 180 m/min (600 ft/min) and Vf = 2.750mm/min in 42CrMo4.

MAIN SHAFT

In a wind turbine, the main shaft is one of the components with the highest loads. Machining a shaft consumes more than 5 hours of processing time to transform cast steel material to a high-precision component with stringent surface requirements.

Kennametal provides industry-leading turning technology to meet this need. The new Beyond™ platform is designed to increase metal removal rates and to extend tool life, up to 2x, in the alloy steels used in the wind industry.

The surface technology of the new Beyond turning grades combine with substrate design, multi-layer coatings, and chip-breakers to deliver higher productivity, longer tool life, and better operating conditions.

Forged 34CrNiMo6CV or 42CrMo4 steel is machined on large lathes with Kennametal heavy duty toolholders. The back end fits all current adaptation systems on the market today.

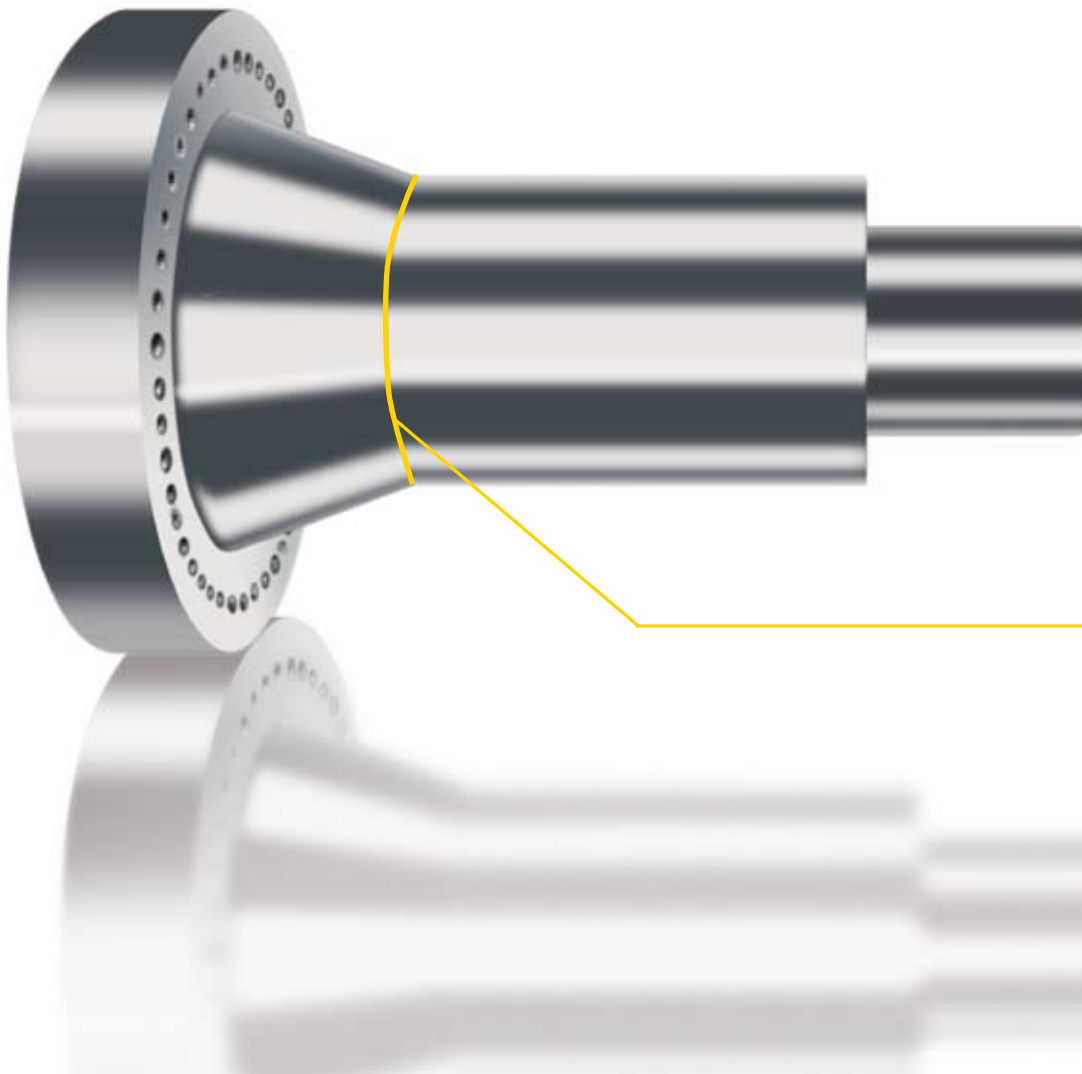



TURNING

BEYOND™ INSERTS

- New Beyond™ turning grades increase tool life up to 100%.
- 30% to 300% more productive 85% of the time.
- Proprietary post-coat treatment and multi-layer coatings.
- Applicable across a wide range of cutting conditions in slow- to high-speed machining.



HOLEMAKING

HTS DRILL

- Proven modular platform up to 450mm (17¾") diameter and up to 3m (10 ft) in length.
- Excellent centering and chip evacuation.
- Cartridges and inserts available for drilling or sinking operations.
- Low power consumption.
- Diameter 270mm x 1.5mm (10⅝" to 60") in 55 min
- Vc = 80 m/min (260 ft/min), f = 0.21/ rev

TURNING

HEAVY-DUTY TURNING TOOLS

- WK or other back end to fit heavy duty lathes.
- Roughing, facing, grooving, and copying toolholders and inserts.
- Wide range of standard inserts in new Beyond grades.
- Roughing: Vc = 50–70 m/min (160–225 ft/min);
f = 0.8 ... 1.5mm (0.030–0.060")
- Finishing: Vc = 50–70 m/min (160–226 ft/min);
f = 0.4–0.6mm (0.016–0.025")



SUSTAINABLE ENGINEERING

***Kennametal leads the way with innovation, engineering,
and service in standard and custom tooling.***

A Proven Methodology and Partnership.

Successful project engineering requires planning, teamwork, and disciplined execution. Through our extensive experience in developing and implementing new project engineering strategies, Kennametal has pioneered a proven methodology to help you manufacture new products and bring them to market quickly. Service deliverables are carefully outlined and jointly agreed upon before the project begins. We formally evaluate progress and results with you throughout the project according to our award-winning stage-gate management systems.

Kennametal can provide your engineering teams and machine tool builders with process engineering support, advanced metalcutting technologies, and project management expertise to help you achieve your sustainability goals. With our best-in-class processes, you'll experience accelerated time-to-market, lower overall costs, and reduced risks to implement new technologies.

**DID YOU
KNOW**

Kennametal has more than 700 highly trained and innovative research scientists and development engineers. They are creating new advanced materials for demanding applications and are designing proprietary components that deliver superior performance for our customers.

**DISCOVERY AND PROPOSAL
DEVELOPMENT**

- Review project needs with customer and/or machine tool builder.
- Customer decision gate: Request proposal.

PROPOSAL PRESENTATION

- Discuss how Kennametal can be of service.
- Customer decision gate: Approve proposal.

BUILD PROJECT PLAN

- Clarify technical and commercial aspects of projects.
- Develop engineering and project schedule.
- Customer decision gate: Approve drawings.

PROJECT PLAN APPROVAL

- Present drawings and confirm order.
- Customer decision gate: Approve project plan and deliverables.

EXECUTION

- Manufacturing.
- Procurement.
- Project Management.
- Assembly.
- Pre-setting.
- Balancing.
- Inspection.
- Shipping.
- Training.
- Run-off Support.

ACCEPTANCE

- Review performance versus contract.
- Customer decision gate: Formal acceptance.

**PRODUCTION RAMP-UP
ASSISTANCE**

- Support program launch schedule through assistance in spare part and consumable procurement planning and further process optimization.

KENNAMETAL COMPLETE™

Our Kennametal Complete™ Program leverages advanced services and a network of strategic alliance partners to address your overall manufacturing productivity and significantly improve your profitability.

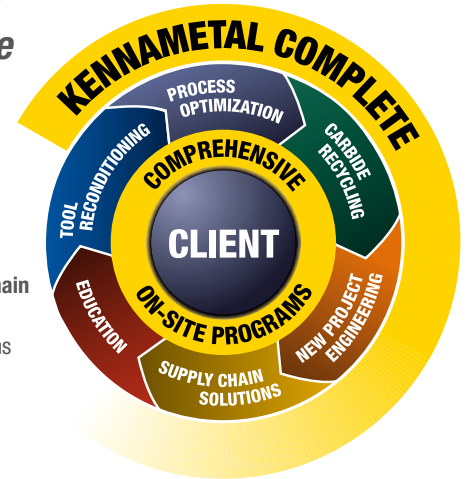

➤ PROCESS OPTIMIZATION

Kennametal Process Optimization Services include:

- Tool selection, application, standardization, and design.
- Workholding and standardization to reduce inventory.
- Operation consolidation to maximize value.
- Lean principles to minimize waste.
- Process sequencing to create flow.

➤ CARBIDE RECYCLING

Logistics Made Simple

It's easy for your company to be environmentally conscious — and there's an added incentive: It is profitable. Through our Carbide Recycling Program, Kennametal will purchase your used carbide (tooling credits available depending on region).

➤ NEW PROJECT ENGINEERING

Using Innovation to Create a Competitive Advantage

Kennametal's New Project Engineering Services have supported the successful launch of hundreds of new manufacturing lines worldwide in the automotive, aerospace, heavy equipment, general engineering, refrigeration equipment, railroad equipment, and marine sectors.

Our value-added services include:

- Lean process development.
- Custom tooling.
- Cost assessments.
- Scheduling, monitoring, and procurement.

➤ SUPPLY CHAIN SERVICES

Why should you use Kennametal Supply Chain Services?

Faster Results — Our proven expertise means we can help you to identify needs, provide solutions, and achieve measurable results quickly and cost effectively.

Disciplined Project Execution — We have implemented hundreds of customized supply chain programs with major manufacturers worldwide, achieving impressive efficiency gains, cost reductions, and other related benefits.

➤ EDUCATION

The Kennametal Knowledge Center supports your efforts to improve productivity and reduce costs by giving you access to:

- Comprehensive engineering courses.
- Industry- and application-specific courses.
- Customized onsite programs and self-paced e-learning.

➤ TOOL RECONDITIONING

Kennametal Reconditioning Services help you optimize the value of your metalcutting tools throughout their service lives by giving them “like-new” performance characteristics — in rapid turnaround time — so the tools you need are always on-hand.

➤ COMPREHENSIVE SERVICE PROGRAM

Through the Kennametal Complete Comprehensive Services Program, we build partnerships that focus on delivering year-over-year productivity improvements through integration into your engineering and production processes via:

- Continuous on-site optimization.
- Concurrent new product/project engineering.
- In-plant logistics.

COMPLETE COMPONENT SOLUTIONS

OPERATION	PRODUCT	HUB	HOUSING	GEARBOX	GENERATOR HOUSING	GEARS	MAIN SHAFT	TOWER	MAIN FRAME	BEARING RING	BLADE	TYPICAL DIAMETER RANGE FOR WIND APPLICATIONS (MM/INCH)	
MILLING	Dodeka KSHR	X	X	X				X	X	X		125–250	4–10"
MILLING	FixPerfect 90° IC15	X	X	X	X				X			125–250	4–10"
MILLING	KSSM 45°/ KSSM 90° IC12	X	X	X	X				X			125–315	4–12"
MILLING	KSRM RCGT20	X	X						X	X		125–250	4–10"
MILLING	KMS PDHX	X	X									100	4"
MILLING	KSSM Helical	X	X	X								80–100	3–4"
MILLING	Brazed Helical	X	X	X								80–100	3–4"
MILLING	Profile Mill	X	X	X								100–200	4–8"
MILLING	Chamfer Mill							X				160–315	6–12"
MILLING	Gear Gasher					X						160–700	6–27.5"
MILLING	Gear Hob					X				X		M6–40	—
HOLEMAKING	HTS	X	X	X			X		X			200–450	7.875–17.750"
HOLEMAKING	KSEM Plus	X	X	X	X		X	X	X	X		32–70	1.250–1.750"
HOLEMAKING	KSEM	X	X	X	X				X			45–270	1.750–10.625"
HOLEMAKING	KenTip	X	X	X	X				X			40–70	1.500–1.750"
HOLEMAKING	DFT/ DFS PCD										X	12.5–73	0.500–2.875"
TAPPING	HSG Taps	X	X	X	X		X		X			M30–80	1.125–3.000"
FINEBORING	ModBORE	X	X	X	X				X			16–83	0.625–3.250"
FINEBORING	Romicron Bridge Tool	X	X	X	X				X			M16–M42	0.625–1.625"
TURNING	Heavy Duty Tools					X	X					150–655	5–25"
TURNING	TTS Boring Bar						X					400–4000	15.750–157.500"
TURNING	Beyond					X	X					—	—

World and Corporate Headquarters

Kennametal Inc.
1600 Technology Way
Latrobe, PA USA 15650
Phone: 800.446.7738 (United States and Canada)
E-Mail: info@kennametal.com

European Headquarters

Kennametal Europe GmbH
Rheingoldstrasse 50
CH 8212 Neuhausen am Rheinfall
Switzerland
Phone: (41).52.6750.100
E-Mail: neuhausen.info@kennametal.com

Asian-Pacific Headquarters

Kennametal Pte. Ltd
No.11 Gul Link Jurong
Singapore 629381
Phone: (65).6.2659222
E-Mail: sales@kennametal.org

India Headquarters

Kennametal India Limited
8/9th Mile, Tumkur Road
Bangalore - 560 073
Phone: +91 (80) 2839 4321
E-mail: bangalore.information@kennametal.com

www.kennametal.com

