

CITYSCAPE 2.0 

7% commodity and
freight surcharge
in effect as of
November 15, 2021

2 0 2 2



Mailing Address: HBF PO Box 8 Hickory NC 28603-0008	Shipping Address: HBF 900 - 12th Street Drive NW Hickory NC 28601-4763	Contact: Phone: 1.855.HBF.2020 828.328.2064 Fax: 828.485.2690 Info: hbfservice@hbf.com www.hbf.com	Order Processing: Phone: 1.855.HBF.2020 828.328.2064 Fax: 828.485.2690 hbforders@hbf.com
---	--	--	---

GENERAL INFORMATION	PAGE		PAGE
ANSI/BIFMA e3-2014e Furniture Sustainability.....	5	Cityscape 2.0 - Freestanding Modular Seating	
COM Ordering Requirements.....	3	One Seat Modular Lounge Seating - Armless with Back.....	16
Combinations of Upholstery Applications.....	4	Two Seat Modular Lounge Seating - Armless with Back.....	17
Dimension Guide.....	5	Three Seat Modular Lounge Seating - Armless with Back.....	18
GSA.....	6	Cityscape 2.0 - Dual-Sided Add-On Modular Seating Units	
HBF Textiles Graded Product.....	8	One Seat Lounge Seating - No Arms, No Back.....	19
High Performance Products.....	6	Two Seat Lounge Seating - No Arms, No Back.....	20
Product Material Options.....	7	Three Seat Lounge Seating - No Arms, No Back.....	21
SCS Indoor Advantage™ Gold Certified.....	5	Pentagon Chaise Lounge Seating - LSF Back.....	22
Seating Ordering Procedure.....	2	Pentagon Chaise Lounge Seating - RSF Back.....	23
Special Code Compliance – CAL 117.....	4	Cityscape 2.0 - Armchairs & Sofas	
Special Code Compliance – CAL 133.....	4	Armchair.....	24
Specifications - Lounge.....	9	Two-Seater.....	25
Specifications - Tables.....	30	Three-Seater.....	26
Spring Down Cushions.....	6	Cityscape 2.0 - Ottomans	
Statement of Line.....	10	Pentagon Ottoman Backless.....	27
Tables - Dimension Guide.....	15	Square Ottoman.....	28
Typical Configurations.....	12	Cityscape 2.0 - Modular Connecting Tables	
Yardage Requirements.....	2	Rectangular with Rectangular Top Table.....	31, 33
		Rectangular with Round Top Table.....	32, 34, 35
		Ganging Leg Kit.....	29
		Power.....	30, 36



Coverings

All upholstered items may be ordered using HBF Textiles, HBF Leathers, or coverings provided by the customer. **Prices listed as COM refer to Customer's Own Material, which includes textiles and leather.** Prices listed as GRADE refer to HBF Textiles and/or HBF Leather.

Yardage requirements shown in the price list are based on non-directional 54" wide material. The following conversion chart should be used to determine yardage requirements when COM textile is 54" wide or less and/or has a repeat of 2" or more. Add together the vertical and horizontal repeat to determine which column should be used as a reference.

Fabric Width	Plain Fabric	2"-10" Repeat	11"-20" Repeat	21"-25" Repeat	26"-30" Repeat	31"-35" Repeat	36"-40" Repeat	41"-45" Repeat
54"	+ 0%	+10%	+15%	+20%	+25%	+30%	+35%	+40%
51"-53"	15%	20%	25%	30%	35%	40%	45%	50%
48"-50"	30%	35%	40%	45%	50%	55%	60%	65%
45"-47"	45%	50%	55%	60%	65%	70%	75%	80%
36"-44"	60%	65%	70%	75%	80%	85%	90%	95%

To determine the possibility of reduced yardage requirements for orders of thirty (30) or more units, please contact The HBF Client Experience Team. HBF reserves the right to request additional yardage of COM at customer expense based on repeat and/or pattern size, and number of rolls.

All COM's must be approved for application before the purchase order is submitted to HBF. Please contact The HBF Client Experience Team at hbfservice@hbf.com to verify that your COM fabric has been approved. If it has not, please request COM approval testing via www.hbf.com under COM Request. Failure to submit a COM for testing may result in additional expenses or rejection of COM. For any repeat and/or pattern size not listed, please contact The HBF Client Experience Team for a yardage requirement quotation.

HBF cannot be held responsible for performance, color accuracy, or weaving of COM materials. All responsibility for COM shipments is between the purchaser and the textile/leather source. HBF reserves the right to reject any COM. HBF assumes no responsibility for suitability or wearability of COM. Difficult COM may be subject to additional charge if additional labor costs are incurred. HBF assumes no responsibility for the flame retardance of any COM. Customers are solely responsible for making sure that COM complies with all applicable codes and regulations. Orders specifying COM will not be scheduled for production until all approved COM(s) are received by HBF. To ensure proper COM expediting, please tag fabric/leather roll(s) with the following information: 1. Purchasing dealer name and purchase order number 2. HBF acknowledgment number, if available 3. Other pertinent information which will enable proper COM identification.

When sending COM leather for use on one of our upholstered pieces, please send eighteen (18) square feet of leather for each yard of 54" plain fabric required for that item.



Coverings (Continued)

COM ORDERING REQUIREMENTS:

Prior to acceptance of order specifying COM, a memo sample must be submitted to HBF for determination of suitability. All COM's must be rolled separately, on individual tubes. Multiple materials rolled on the same tube will not be accepted.

For ease of expediting your COM order, we require the following information:

- | | |
|---|------------------------------|
| 1. Material description | Shipping Address: HBF |
| 2. Material source | 900 12th Street Drive NW |
| 3. Order line, product name or number | Hickory, NC 28601-4763 |
| 4. Material color | |
| 5. A swatch of the covering | |
| 6. Special application instructions, if any | |

If COM is of a type requiring choices of seam placement, face side, position of design or repeat; these instructions must be clearly stated on the original order.

HBF cannot be held responsible for performance, color accuracy, or weaving of COM materials. All responsibility for COM shipments is between the purchaser and the textile/leather source.

HBF reserves the right to reject any COM. HBF assumes no responsibility for suitability or wearability of COM. Difficult COM may be subject to additional charge if additional labor costs are incurred.

HBF assumes no responsibility for the flame retardance of any COM. Customers are solely responsible for making sure that COM complies with all applicable codes and regulations.

Orders specifying COM will not be scheduled for production until all approved COM is received by HBF.

To ensure proper COM expediting, please tag textile/leather with the following information:

1. Purchasing dealer name and purchase order number
2. HBF acknowledgement number, if available
3. Other pertinent information which will enable proper COM identification



Combination of Upholstery Applications

All seating ordered with combination upholstery application (fabric, leather) that **is not** offered as standard is subject to a **\$103 List Upholstery upcharge** and will be entered and processed as a special model, in addition to the following pricing conditions:

1. Combinations using HBF Textiles and COM will be priced at the COM price. The cost of the portion of the HBF Textiles used, will be entered as a miscellaneous charge on the furniture order.
2. Combinations using HBF Textiles and HBF Leathers, or COM and HBF Leathers, will be priced at the appropriate Leather I-V price.
3. Combinations using two HBF Textiles will be invoiced at higher grade price.
4. When specifying combination of upholstery applications, a sketch indicating placement of textiles and direction of applications must accompany the purchase order.

Special Code Compliance

California #117-2013

Unless otherwise specified, foam used in all HBF seating products complies with these guidelines.

California #133

Following are the Net upcharges and minimum unit requirements for special construction to comply with these guidelines.

Guest Chairs	\$113 Net per unit (minimum of two units)
Swivel Chairs	\$167 Net per unit (minimum of two units)
Lounge Chairs	\$233 Net per unit
Ottomans	\$113 Net per unit
Loveseats	\$303 Net per unit
Sofas	\$352 Net per unit
Bench Seating	\$167 Net per unit (regardless of size)

HBF can not be held liable if original purchase order does not indicate a requirement for California #133 compliance.

Boston Fire Code

New York Port Authority

Please contact the HBF Client Experience Team if compliance is required for these special codes.



ANSI/BIFMA e3-2014e Furniture Sustainability Standard and LEVEL® Certification

A majority of HBF's products have met the necessary qualifications to achieve LEVEL® certification. LEVEL® is the multi-attribute sustainability certification based on the ANSI/BIFMA e3 Furniture Sustainability Standard. The standard and certification were created to deliver the most open and transparent means of evaluating and communicating the environmental and social impacts of furniture products in the built environment. Taking into account a company's social actions, energy usage, material selection and human and ecosystem health impacts, LEVEL® addresses how a product is sustainable from multiple perspectives. The organization, facilities, and products are audited on an annual basis to ensure ongoing compliance and improvement.

With LEVEL®, customers can make informed choices about sustainable commercial office furniture. The LEVEL® mark identifies that a product has been vetted by an independent third party certifier and its numeric marking of 1, 2, or 3 indicates the threshold of certification the product has achieved. A majority of HBF's seating, occasional tables, and conference lines are LEVEL® certified. Please download the certificates from our product pages for the complete details. For more information about the ANSI/BIFMA LEVEL® standard, visit www.levelcertified.org.

ANSI/BIFMA Performance Standards

Our seating products meet or exceed ANSI/BIFMA weight performance standards of 275 lbs. (124.7 kg.) unless otherwise noted.

SCS Indoor Advantage™

All HBF seating products are SCS Indoor Advantage™ Gold Certified.

SCS Global Services (SCS), a reputable third-party certification and assessment body of environmental, sustainability and safety claims since 1984, has developed internationally recognized standards and certification programs to assist businesses with improving their environmental efforts, social accountability and product performance.

The advantages of holding SCS Indoor Air Quality certification are substantial: in addition to improving indoor working environments and meeting qualifications for the LEED-CI EQ 4.5 credit for office furniture as well as the BIFMA Standard for Low-Emitting Office Furniture Systems & Seating M-7.1, there is the added assurance of knowing that the company's entire breadth of products is held to such rigorous standards.

For more information regarding SCS Indoor Advantage™, please visit: <http://www.scsglobalservices.com>.

Please contact the HBF Client Experience Team for pricing and lead time information.

Dimension Guide

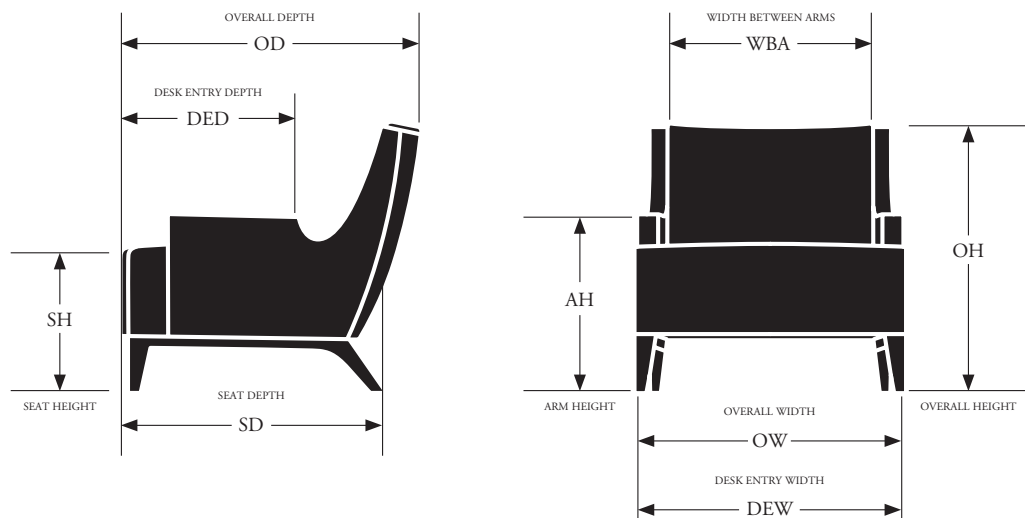



GSA Contract Number Please refer to the GSA price list for pricing.
GS-28F 0020M

HBF High Performance Products HBF and HBF Textiles have long been leaders in contract furnishings and known for industry-leading product design coupled with the highest quality construction, comfort and aesthetic beauty.

Now these same principals are the cornerstones of HBF Healthcare high performance products. We have consulted with healthcare designers and clients to provide products and options for interiors that will provide quality sustainable design solutions for the future. These effective solutions will address the unique interactions required by any high-use facility. Visit www.hbf.com for additional high performance product information.

Seating Product High Performance Options:

- Guest and Lounge Seating
- Arm Caps
- Moisture Barrier
- Wipe Out - Clean Out
- Tandem Seating
- Wall Saver Legs
- Replaceable Components
- Upholstery Products from HBF Textiles

Spring Down Cushions Optional spring down cushions are available on most loose cushion HBF lounge seating. List upcharges are:

Chair	\$108
Loveseat	\$194
Sofa	\$297



POWDER COATS:



BL
Black



WI
White



LG
Light Grey

METAL:



POL
Polished Chrome

LAMINATES: (PL) *Note: Available for modular table surfaces.*



PL7943
Columbian Walnut

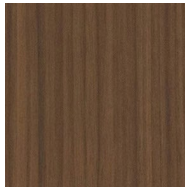

PL7965
Walnut Heights



PL8238
Fairchild



PLBW
Beigewood



PLDW1
Designer White

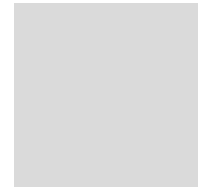

M11
Loft Grey Cloud

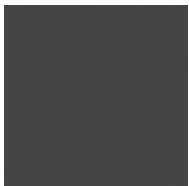

M16
Flint



PT1
Portico Teak



Grade A	Grade B	Grade C	Grade D	Grade E	Grade F
Against the Grain	Caddy Corner	Bumpy	Butterfly	Dashing	All Terrain
Blink	Chenille Straie	Checkmate	Crew Cut	Faux Real II	Beetle
Denim Wash	Cuddle Up	Poppy	Habu	Fourfold	Cloverleaf
Upbeat	Look-see		Happy Camper	Here & There	Comfort Zone
Walkabout	Picnic Plaid		Honest	Modern Tweed	Crafted Felt
	Zippy		Mirage	Pebbled	Curtain Wall
			Parker	Sherpa	Folded Lines
			Roundabout		High Rise
			Weekender		Madam Dottie
					Moving In
					Roy's Cords
					Scribble XS
					Upscale
					Uptown
					Wabi Sabi
Grade G	Grade H	Grade J	Grade K	Grade L	Grade M
Air Mail	Abito	Belgian Meadow	Afghan	Double Stitch	Bunny
Argyle Boucle	Brushed Canvas	Captain Bubble	Hipster	Flirt	Crafted Cloud
Color Code	Cloud	Cherished Knit	Landscape Blur	Honest Square	Eccentric
Digital Bloom 2.0	Complex	Crosstweed	Polygone	Mr. Dimple	Knitwork
Equation	Cutout	Enriched Boucle	Poodle	Ms. Quilty	
Outdoor Check	Dot Grid	Foundation	Smart	Sweater	
Remember	Dot Structure	Heartfelt	Velvet Mix		
Tickled Herring	Glint	Italian Wool	Woven Memory		
	Grateful Grid	Merci Boucle			
	Lava Rock	Moving Blanket			
	Linkage	Moving Forward			
	Moss	Night Earth			
	Sir Stripe-a-lot	Pepper Blend			
	Soft Angles 2.0	Quill			
	Sweater Weather	Quilted Comfort			
	Twist	Sable Island			
	Upstart	Scribble XL			
	Uptick	Sideways			
		Sister Solid			
		Woodblock			
Leather I	Leather II	Leather III	Leather IV	Leather V	Leather VI
Clutch	Aviator	Free Way	Attaché	Upper Crust	Modern Patina
Vivace II		Pearl	Persuede	Voyage	
		Wild West			



Cityscape Specifications

Collection Details One Seat Lounge | Two Seat Lounge | Three Seat Lounge | Pentagon Ottoman | Square Ottoman
Upholstered

Base Metal Options Black Powder Coat | Grey Powder Coat | White Powder Coat | Polished Chrome

**Ganging Bracket
Leg Assembly Kit** Available. *(Ordered separately)*
Configuration Note: Ganging bracket leg kit is required when attaching any seat to any seat.

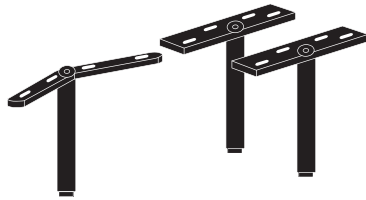

Fabric Placement

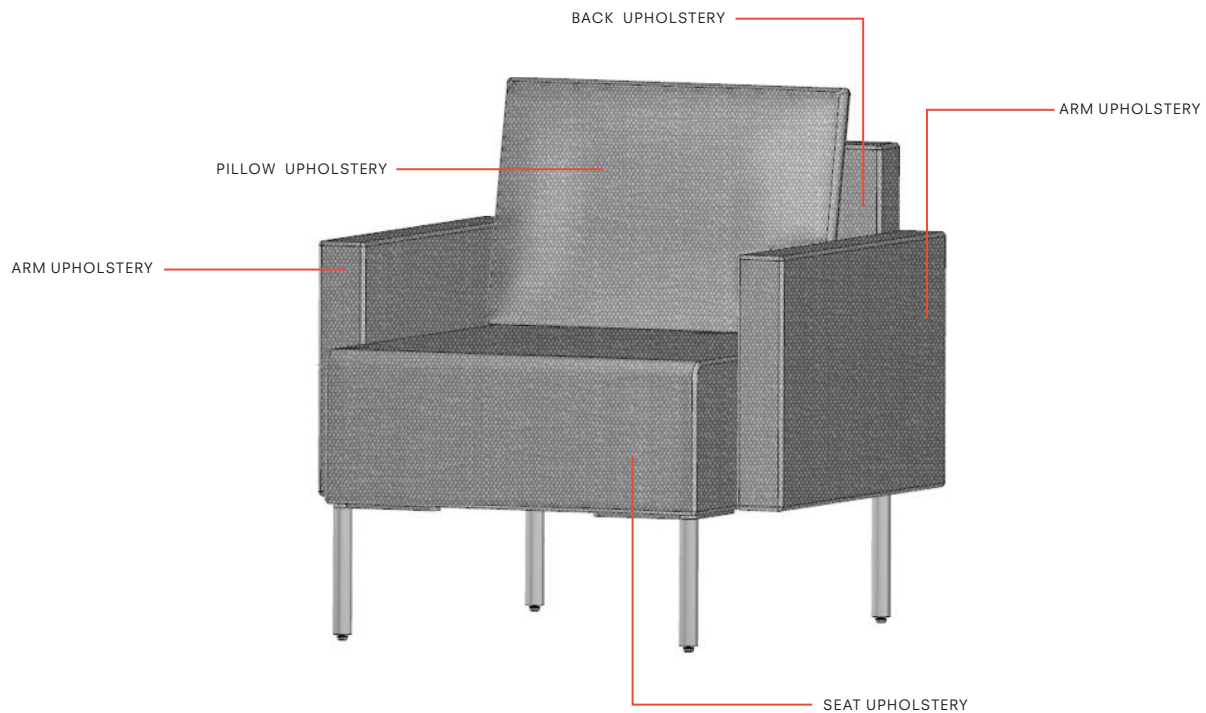



CITYSCAPE 2.0 FREESTANDING MODULE SEATING WITH ARMS

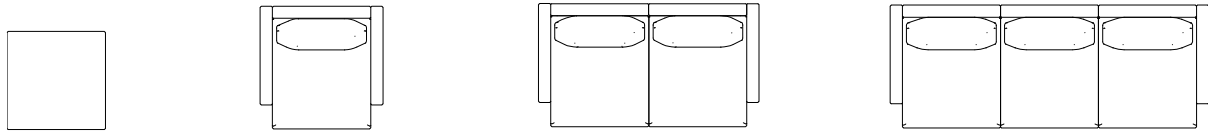
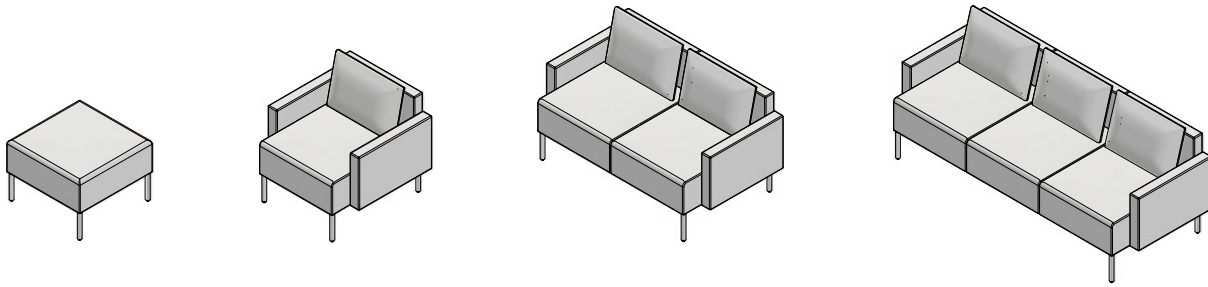

HLD421-044

HLD421-041

HLD421-042

HLD421-043

CITYSCAPE 2.0 FREESTANDING ARMLESS MODULE SEATING

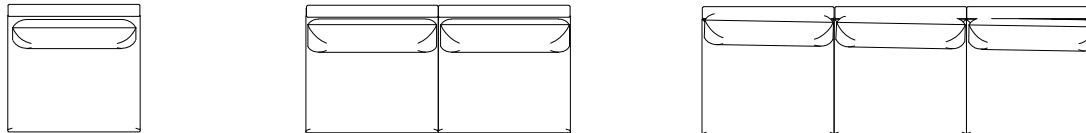
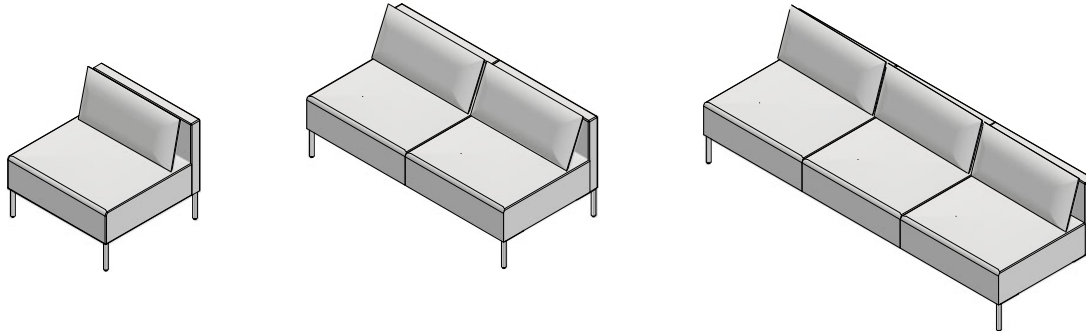

HLD421-021

HLD421-022

HLD421-023

CITYSCAPE 2.0 FREESTANDING PENTAGON UNITS

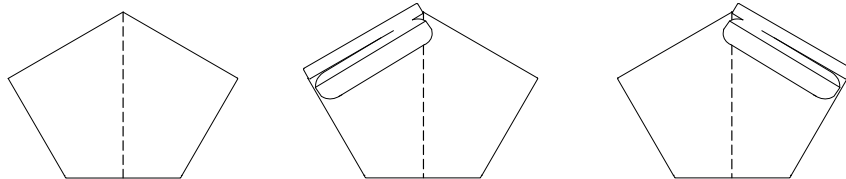
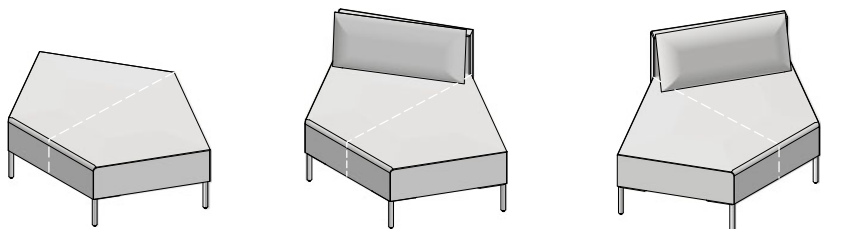

---- = Upholstery Seam

HLD421-014

HLD421-024

HLD421-034



CITYSCAPE 2.0 MODULAR RECTANGULAR CONNECTING TABLES

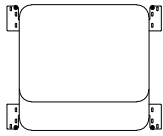
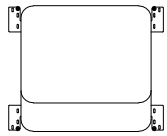
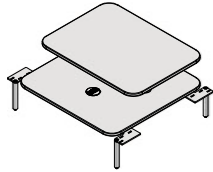
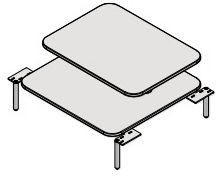

HTD42101-3231

HTD42102-3231

CITYSCAPE 2.0 GANGING BRACKET LEG ASSEMBLY KIT



HAD421-010

CITYSCAPE 2.0 MODULAR RECTANGULAR CONNECTING TABLES WITH ROUND TOPS

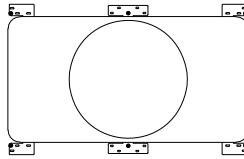
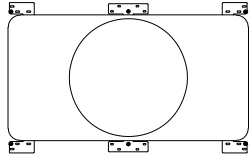
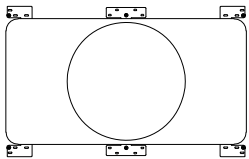
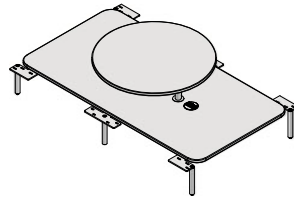
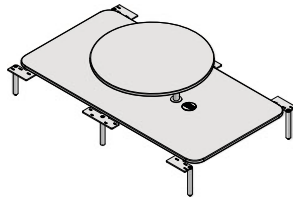
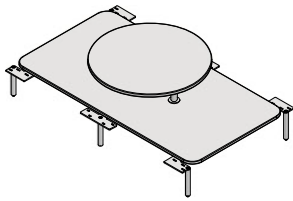

HTD42101-5931

HTD42102-5931

HTD42103-5931

CITYSCAPE 2.0 MODULAR DUAL-SIDED ADD-ON SEATING UNITS WITHOUT BACKS*

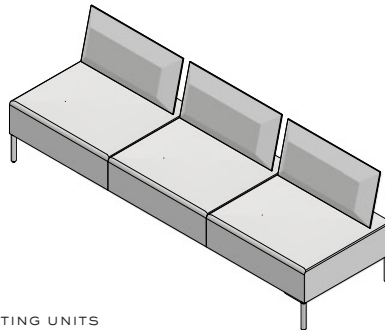
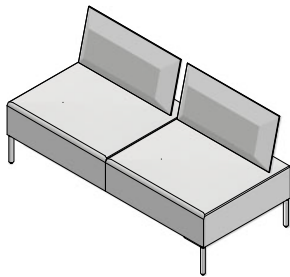
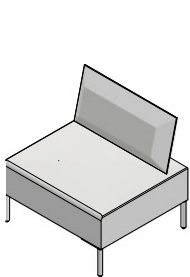

*TO BE USED IN A SHARED BACK APPLICATION WITH FREESTANDING MODULAR SEATING UNITS

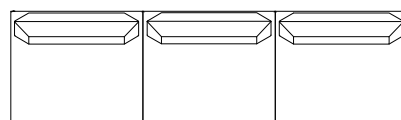
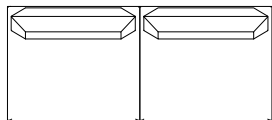
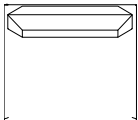

HLD421-011

HLD421-012

HLD421-013



CONFIGURATION 1

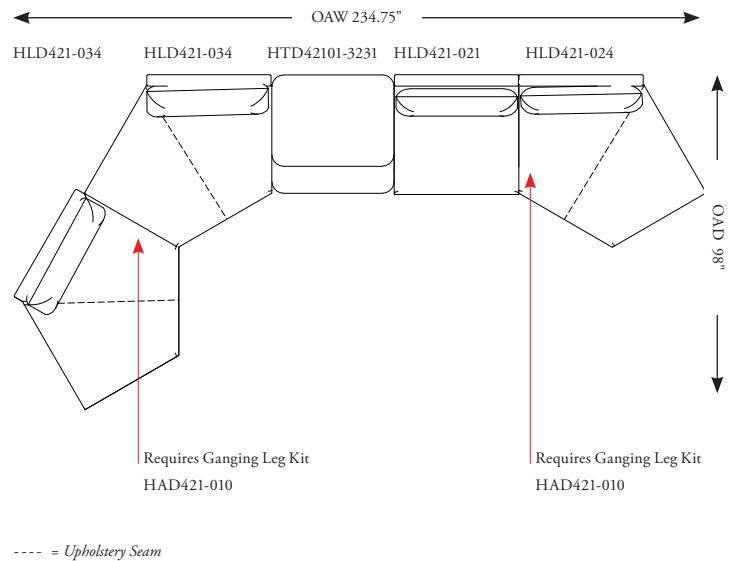
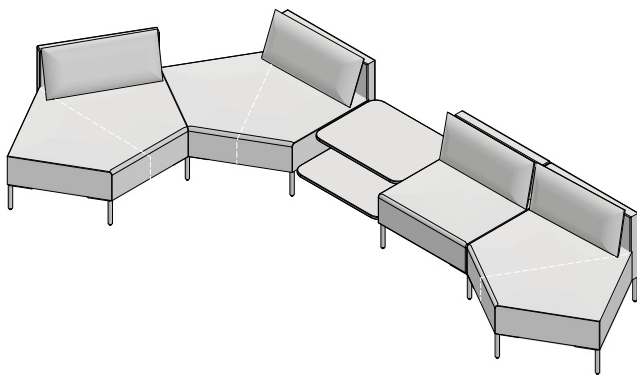

Notes:

Two extra HAD421-010 ganging bracket leg kits are required for this configuration type.

One seat modular (HLD421-021) can be interchanged with two seat modular (HLD421-022) or three seat modular (HLD421-023) at any location shown.

CONFIGURATION 2

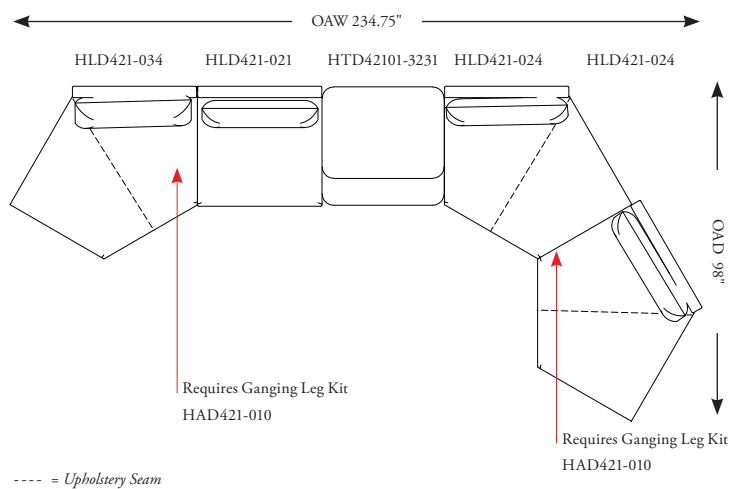
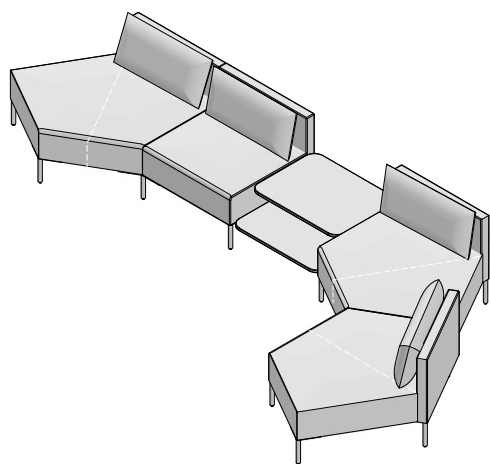

Notes:

Two extra HAD421-010 ganging bracket leg kits are required for this configuration type.

One seat modular (HLD421-021) can be interchanged with two seat modular (HLD421-022) or three seat modular (HLD421-023) at any location shown.



CONFIGURATION 3

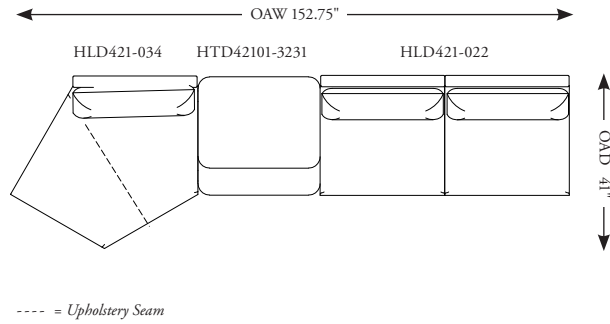
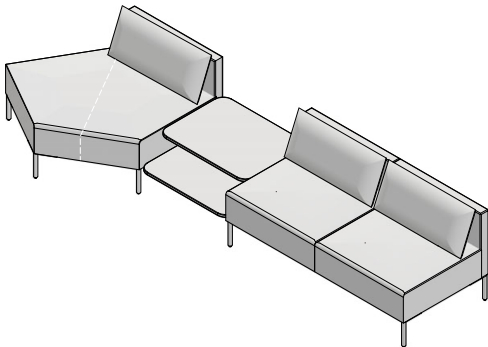

Notes:

Additional ganging bracket leg kits (HAD421-010) are not required for this configuration assembly.

Two seat modular (HLD421-022) can be interchanged with one seat modular (HLD421-021) or three seat modular (HLD421-023) at any location shown.

CONFIGURATION 4

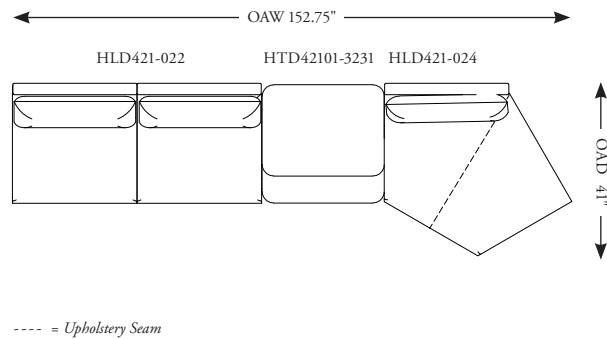
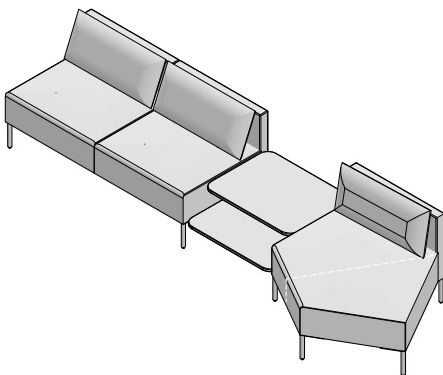

Notes:

Additional ganging bracket leg kits (HAD421-010) are not required for this configuration assembly.

Two seat modular (HLD421-022) can be interchanged with one seat modular (HLD421-021) or three seat modular (HLD421-023) at any location shown.



CONFIGURATION 5

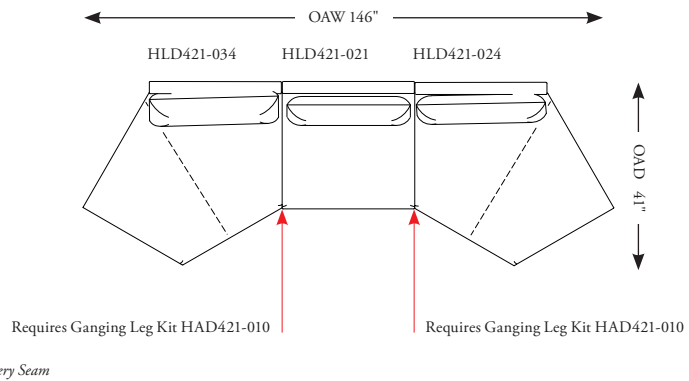
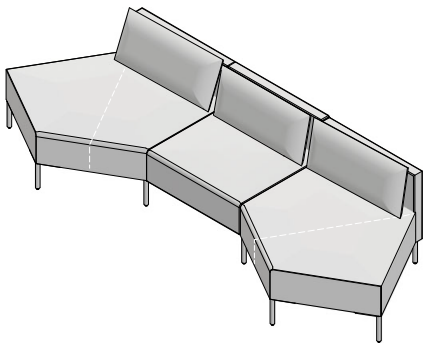

Notes:

HLD421-021 can be interchanged with or added to HLD421-022 or HLD421-023 between HLD421-034 and HLD421-024.

Either HLD421-034 or HLD421-024 or both can be removed from this configuration.

This type of configuration cannot include back-to-back seating options.

Two extra HAD421-010 ganging bracket leg kits are required for this configuration type.

CONFIGURATION 6

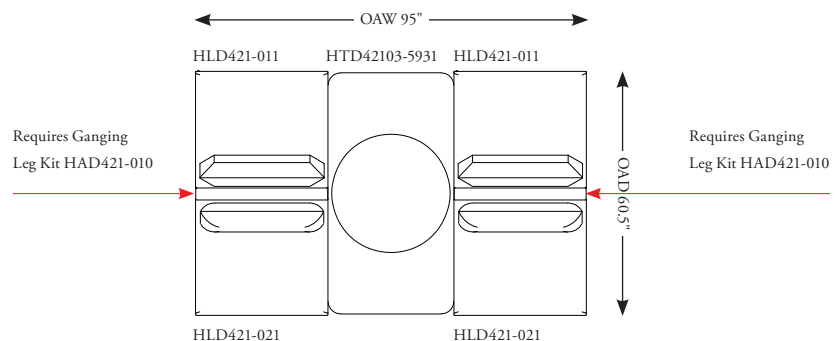
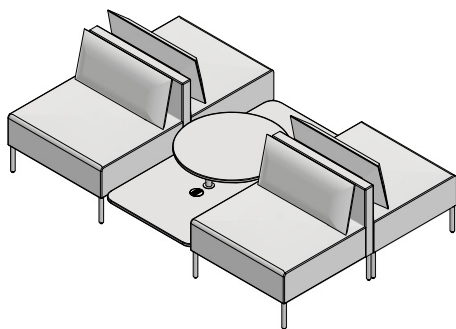

Notes:

One seat modular (HLD421-021) can be interchanged with two seat modular (HLD421-022) or three seat modular (HLD421-023) at any location shown.

When using this type of configuration: HLD421-011 must attach to the back of HLD421-021

HLD421-012 must attach to the back of HLD421-022

HLD421-013 must attach to the back of HLD421-023

HTD42103-5931 table can be interchanged with HTD42101-5931 or HTD42102-5931 tables front to back as shown.

This type of configuration cannot have seating next to seating, a table must go between them.

Two additional ganging bracket leg kits (HAD421-010) are required for this configuration assembly.



CITYSCAPE 2.0 *General Dimensions*

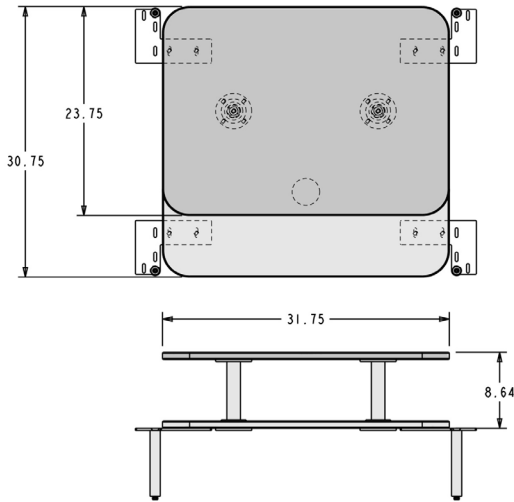

HTD42101-3231
HTD42102-3231

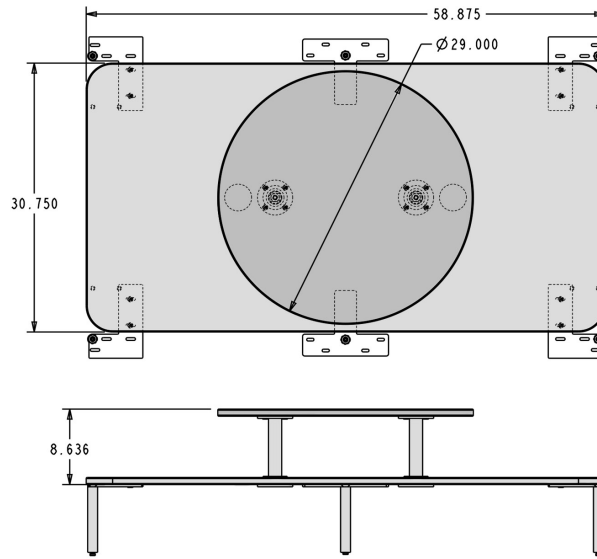

HTD42101-5931
HTD42102-5931
HTD42103-5931

CITYSCAPE 2.0 *Power Location(s)*

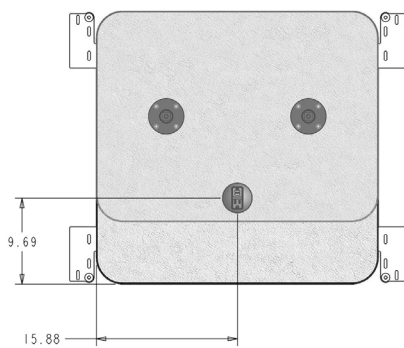

HTD42102-3231

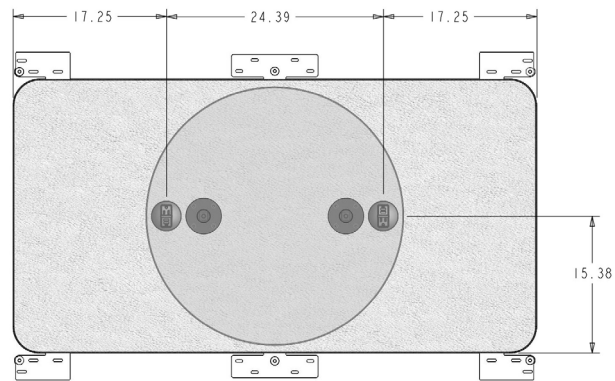

HTD42102-5931 with One Power Location
HTD42103-5931 with Two Power Locations

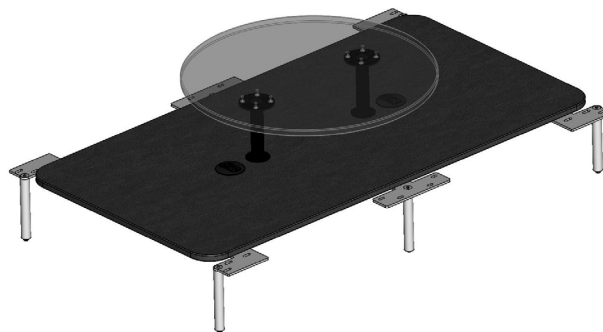



Dimensions

Cityscape 2.0 HLD421-021



OH	31½	AH
OW	32	WBA
OD	31½	DED
SH	17½	DEW
SD	28½	R

Shipping Weight	63
Cube	17.8

One Seat Lounge | No Arms | With Back | Pillow | Fully Upholstered | Black Powder Coat Base

LEVEL® Certified
SCS Indoor Advantage™ Certified

Configuration Note: Can be stand alone model

Pricing for Single Fabric Placement:

To calculate price, begin with Grade A Single Fabric Pricing on the left, and add the following upcharges for Multiple Fabric Placement Options:

Upholstery:	Back Upholstery:	Seat Upholstery:	Pillow Upholstery:
Grade A 2190	Grade A 65	Grade A 110	Grade A 65
Grade B 2260	Grade B 85	Grade B 140	Grade B 85
COM/Grade C 2315	COM/Grade C 100	COM/Grade C 165	COM/Grade C 100
Grade D 2375	Grade D 115	Grade D 195	Grade D 115
Grade E 2440	Grade E 135	Grade E 220	Grade E 135
Grade F 2515	Grade F 155	Grade F 255	Grade F 155
Grade G 2595	Grade G 175	Grade G 295	Grade G 175
Grade H 2685	Grade H 200	Grade H 335	Grade H 200
Grade J 2740	Grade J 215	Grade J 360	Grade J 215
Grade K 2865	Grade K 250	Grade K 415	Grade K 250
Grade L 3050	Grade L 300	Grade L 500	Grade L 300
Grade M 3290	Grade M 365	Grade M 610	Grade M 365
Leather I 3710	Leather I 480	Leather I 800	Leather I 480
Leather II 4150	Leather II 600	Leather II 1000	Leather II 600
Leather III 4590	Leather III 720	Leather III 1200	Leather III 720
Leather IV 5030	Leather IV 840	Leather IV 1400	Leather IV 840
Leather V 5470	Leather V 960	Leather V 1600	Leather V 960
Leather VI 5910	Leather VI 1080	Leather VI 1800	Leather VI 1080
Upholstery Requires:	Upholstery Requires (Per Application):	Upholstery Requires (Per Application):	Upholstery Requires (Per Application):
Fabric: 5½ Yards Leather: 99 Sq. Ft.	Fabric: 1½ Yards Leather: 27 Sq. Ft.	Fabric: 2½ Yards Leather: 45 Sq. Ft.	Fabric: 1½ Yard Leather: 27 Sq. Ft.

Total Required Upholstery: Fabric: 5½ Yards
Leather: 99 Sq. Ft.

PLEASE SPECIFY THE FOLLOWING TO ORDER:

<p>MODEL NUMBER</p>	<p>TEXTILES</p> <p>Indicate fabric choice: Back</p> <p><i>See options for fabrics at www.hbf textiles.com</i></p>	<p>TEXTILES</p> <p>Indicate fabric choice: Seat</p> <p><i>See options for fabrics at www.hbf textiles.com</i></p>	<p>TEXTILES</p> <p>Indicate fabric choice: Pillow</p> <p><i>See options for fabrics at www.hbf textiles.com</i></p>	<p>FLAMMABILITY</p> <p>Indicate flammability:</p> <p>U = Cal 117 U3 = Cal 133</p>	<p>BASE FINISH</p> <p>Options for metal finish:</p> <p>BL = Black Powder Coat WI = White Powder Coat +\$50 LG = Light Grey Powder Coat +\$50 POL = Polished Chrome +\$200</p>
----------------------------	--	--	--	--	--

HLD421-021.FabBack.FabSeat.FabPillow.Flammability.Base Example: HLD421-021.950-88.950-88.950-88.U.BL



Dimensions

Cityscape 2.0 HLD421-022



OH	31½	AH
OW	64	WBA
OD	31½	DED
SH	17½	DEW
SD	28½	R

Shipping Weight 104
Cube 43

LEVEL® Certified
SCS Indoor Advantage™ Certified

Two Seat Lounge | No Arms | With Back | Pillow | Fully Upholstered | Black Powder Coat Base

Configuration Note: Can be stand alone model

Pricing for Single Fabric Placement:

Upholstery:

Grade A	2830
Grade B	2935
COM/Grade C	3045
Grade D	3155
Grade E	3260
Grade F	3390
Grade G	3545
Grade H	3695
Grade J	3805
Grade K	4020
Grade L	4345
Grade M	4780
Leather I	5515
Leather II	6295
Leather III	7075
Leather IV	7855
Leather V	8635
Leather VI	9415

Upholstery Requires:

Fabric: 9¾ Yards
Leather: 175½ Sq. Ft.

To calculate price, begin with Grade A Single Fabric Pricing on the left, and add the following upcharges for Multiple Fabric Placement Options:

Back Upholstery:

Grade A	135
Grade B	165
COM/Grade C	200
Grade D	235
Grade E	265
Grade F	305
Grade G	355
Grade H	400
Grade J	435
Grade K	500
Grade L	600
Grade M	735
Leather I	960
Leather II	1200
Leather III	1440
Leather IV	1680
Leather V	1920
Leather VI	2160

Upholstery Requires (Per Application):

Fabric: 3 Yards
Leather: 54 Sq. Ft.

Seat Upholstery:

Grade A	180
Grade B	220
COM/Grade C	265
Grade D	310
Grade E	355
Grade F	410
Grade G	470
Grade H	535
Grade J	580
Grade K	665
Grade L	800
Grade M	980
Leather I	1280
Leather II	1600
Leather III	1920
Leather IV	2240
Leather V	2560
Leather VI	2880

Upholstery Requires (Per Application):

Fabric: 4 Yards
Leather: 72 Sq. Ft.

Pillow Upholstery:

Grade A	120
Grade B	155
COM/Grade C	185
Grade D	215
Grade E	245
Grade F	280
Grade G	325
Grade H	365
Grade J	395
Grade K	460
Grade L	550
Grade M	670
Leather I	880
Leather II	1100
Leather III	1320
Leather IV	1540
Leather V	1760
Leather VI	1980

Upholstery Requires (Per Application):

Fabric: 2¾ Yard
Leather: 49½ Sq. Ft.

Total Required

Upholstery: Fabric: 9¾ Yards
Leather: 175½ Sq. Ft.

PLEASE SPECIFY THE FOLLOWING TO ORDER:

<p>MODEL NUMBER</p>	<p>TEXTILES</p> <p>Indicate fabric choice: Back</p> <p><i>See options for fabrics at www.hbf textiles.com</i></p>	<p>TEXTILES</p> <p>Indicate fabric choice: Seat</p> <p><i>See options for fabrics at www.hbf textiles.com</i></p>	<p>TEXTILES</p> <p>Indicate fabric choice: Pillow</p> <p><i>See options for fabrics at www.hbf textiles.com</i></p>	<p>FLAMMABILITY</p> <p>Indicate flammability:</p> <p>U = Cal 117 U3 = Cal 133</p>	<p>BASE FINISH</p> <p>Options for metal finish:</p> <p>BL = Black Powder Coat WI = White Powder Coat +\$50 LG = Light Grey Powder Coat +\$50 POL = Polished Chrome +\$200</p>
----------------------------	--	--	--	--	--

HLD421-022.FabBack.FabSeat.FabPillow.Flammability.Base Example: HLD421-022.950-88.950-88.950-88.U.BL



Dimensions

Cityscape 2.0 HLD421-023



OH	31½	AH
OW	96	WBA
OD	31½	DED
SH	17½	DEW
SD	28½	R

Shipping Weight	159
Cube	63.6

Three Seat Lounge | No Arms | With Back | Pillow | Fully Upholstered | Black Powder Coat Base

LEVEL® Certified
SCS Indoor Advantage™ Certified

Configuration Note: Can be stand alone model

Pricing for Single Fabric Placement:

To calculate price, begin with Grade A Single Fabric Pricing on the left, and add the following upcharges for Multiple Fabric Placement Options:

Upholstery:	Back Upholstery:	Seat Upholstery:	Pillow Upholstery:
Grade A 4215	Grade A 200	Grade A 235	Grade A 165
Grade B 4365	Grade B 250	Grade B 290	Grade B 210
COM/Grade C 4515	COM/Grade C 300	COM/Grade C 350	COM/Grade C 250
Grade D 4665	Grade D 350	Grade D 410	Grade D 290
Grade E 4815	Grade E 400	Grade E 465	Grade E 335
Grade F 4995	Grade F 460	Grade F 535	Grade F 385
Grade G 5205	Grade G 530	Grade G 620	Grade G 440
Grade H 5415	Grade H 600	Grade H 700	Grade H 500
Grade J 5565	Grade J 650	Grade J 760	Grade J 540
Grade K 5865	Grade K 750	Grade K 875	Grade K 625
Grade L 6315	Grade L 900	Grade L 1050	Grade L 750
Grade M 6915	Grade M 1100	Grade M 1285	Grade M 915
Leather I 7935	Leather I 1440	Leather I 1680	Leather I 1200
Leather II 9015	Leather II 1800	Leather II 2100	Leather II 1500
Leather III 10,095	Leather III 2160	Leather III 2520	Leather III 1800
Leather IV 11,175	Leather IV 2520	Leather IV 2940	Leather IV 2100
Leather V 12,255	Leather V 2880	Leather V 3360	Leather V 2400
Leather VI 13,335	Leather VI 3240	Leather VI 3780	Leather VI 2700
Upholstery Requires:	Upholstery Requires (Per Application):	Upholstery Requires (Per Application):	Upholstery Requires (Per Application):
Fabric: 13½ Yards Leather: 243 Sq. Ft.	Fabric: 4½ Yards Leather: 81 Sq. Ft.	Fabric: 5¼ Yards Leather: 94½ Sq. Ft.	Fabric: 3¾ Yard Leather: 67½ Sq. Ft.

Total Required

Upholstery: Fabric: 13½ Yards
Leather: 243 Sq. Ft.

PLEASE SPECIFY THE FOLLOWING TO ORDER:

<p>MODEL NUMBER</p>	<p>TEXTILES</p> <p>Indicate fabric choice: Back</p> <p><i>See options for fabrics at www.hbftextiles.com</i></p>	<p>TEXTILES</p> <p>Indicate fabric choice: Seat</p> <p><i>See options for fabrics at www.hbftextiles.com</i></p>	<p>TEXTILES</p> <p>Indicate fabric choice: Pillow</p> <p><i>See options for fabrics at www.hbftextiles.com</i></p>	<p>FLAMMABILITY</p> <p>Indicate flammability:</p> <p>U = Cal 117 U3 = Cal 133</p>	<p>BASE FINISH</p> <p>Options for metal finish:</p> <p>BL = Black Powder Coat WI = White Powder Coat +\$50 LG = Light Grey Powder Coat +\$50 POL = Polished Chrome +\$200</p>
----------------------------	--	--	--	--	--

HLD421-023.FabBack.FabSeat.FabPillow.Flammability.Base Example: HLD421-023.950-88.950-88.950-88.U.BL



CITYSCAPE 2.0 MODULAR SEATING

DUAL-SIDE ADD-ON UNIT, ONE SEAT LOUNGE
NO ARMS / NO BACK

Dimensions

Cityscape 2.0 HLD421-011



OH	17½	AH
OW	32	WBA
OD	28½	DED
SH	17½	DEW
SD	28½	R

Shipping Weight	49
Cube	17.8

Dual-Side Add-On Unit | One Seat Lounge | No Arms | No Back | Pillow | Fully Upholstered | Black Powder Coat Base | Pillow Clips

Note: To be used in a shared application with freestanding modular seating unit HLD421-021.

LEVEL® Certified
SCS Indoor Advantage™ Certified

Configuration Note: Cannot be stand alone model and must be attached back-to-back with HLD421-021.

Dual-sided seating cannot attach to the pentagons.

Dual-sided seating cannot attach to another dual-sided seating configuration unless connecting table models are added in between.

Model HTD42101-5931, HTD42102-5931 or HTD42103-5931 must go in between.

Pricing for Single Fabric Placement:

Upholstery:

Grade A	1685
Grade B	1735
COM/Grade C	1775
Grade D	1820
Grade E	1865
Grade F	1920
Grade G	1980
Grade H	2045
Grade J	2085
Grade K	2175
Grade L	2310
Grade M	2485
Leather I	2790
Leather II	3110
Leather III	3430
Leather IV	3750
Leather V	4070
Leather VI	4390

Upholstery Requires:

Fabric:	4	Yards
Leather:	72	Sq. Ft.

To calculate price, begin with Grade A Single Fabric Pricing on the left, and add the following upcharges for Multiple Fabric Placement Options:

Seat Upholstery:

Grade A	110
Grade B	140
COM/Grade C	165
Grade D	195
Grade E	220
Grade F	255
Grade G	295
Grade H	335
Grade J	360
Grade K	415
Grade L	500
Grade M	610
Leather I	800
Leather II	1000
Leather III	1200
Leather IV	1400
Leather V	1600
Leather VI	1800

Upholstery Requires (Per Application):

Fabric:	2½	Yards
Leather:	45	Sq. Ft.

Pillow Upholstery:

Grade A	65
Grade B	85
COM/Grade C	100
Grade D	115
Grade E	135
Grade F	155
Grade G	175
Grade H	200
Grade J	215
Grade K	250
Grade L	300
Grade M	365
Leather I	480
Leather II	600
Leather III	720
Leather IV	840
Leather V	960
Leather VI	1080

Upholstery Requires (Per Application):

Fabric:	1½	Yards
Leather:	27	Sq. Ft.

Total Required

Upholstery:	Fabric:	4	Yards
	Leather:	72	Sq. Ft.

PLEASE SPECIFY THE FOLLOWING TO ORDER:

MODEL NUMBER	TEXTILES Indicate fabric choice: Seat See options for fabrics at www.hbf textiles.com	TEXTILES Indicate fabric choice: Pillow See options for fabrics at www.hbf textiles.com	FLAMMABILITY Indicate flammability: U = Cal 117 U3 = Cal 133	BASE FINISH Options for metal finish: BL = Black Powder Coat WI = White Powder Coat +\$50 LG = Light Grey Powder Coat +\$50 POL = Polished Chrome +\$200
---------------------	---	---	--	--

HLD421-011.FabSeat.FabPillow.Flammability.Base Example: HLD421-011.950-88.950-88.U.BL



CITYSCAPE 2.0 MODULAR SEATING

DUAL-SIDE ADD-ON UNIT, TWO SEAT LOUNGE
NO ARMS / NO BACK

Dimensions

Cityscape 2.0 HLD421-012



OH	17½	AH
OW	64	WBA
OD	28½	DED
SH	17½	DEW
SD	28½	R

Shipping Weight	84
Cube	35.6

Dual-Side Add-On Unit | Two Seat Lounge | No Arms | No Back | Pillow | Fully Upholstered | Black Powder Coat Base | Pillow Clips

Note: To be used in a shared application with freestanding modular seating unit HLD421-022.

LEVEL® Certified
SCS Indoor Advantage™ Certified

Configuration Note: Cannot be stand alone model and must be attached back-to-back with HLD421-022.

Dual-sided seating cannot attach to the pentagons.

Dual-sided seating cannot attach to another dual-sided seating configuration unless connecting table models are added in between. Model HTD42101-5931, HTD42102-5931 or HTD42103-5931 must go in between.

Pricing for Single Fabric Placement:

Upholstery:

Grade A	2400
Grade B	2475
COM/Grade C	2550
Grade D	2625
Grade E	2700
Grade F	2790
Grade G	2895
Grade H	3000
Grade J	3075
Grade K	3225
Grade L	3450
Grade M	3750
Leather I	4260
Leather II	4800
Leather III	5340
Leather IV	5880
Leather V	6420
Leather VI	6960

Upholstery Requires:

Fabric: 6¾ Yards
Leather: 121½ Sq. Ft.

To calculate price, begin with Grade A Single Fabric Pricing on the left, and add the following upcharges for Multiple Fabric Placement Options:

Seat Upholstery:

Grade A	180
Grade B	220
COM/Grade C	265
Grade D	310
Grade E	355
Grade F	410
Grade G	470
Grade H	535
Grade J	580
Grade K	665
Grade L	800
Grade M	980
Leather I	1280
Leather II	1600
Leather III	1920
Leather IV	2240
Leather V	2560
Leather VI	2880

Upholstery Requires (Per Application):

Fabric: 4 Yards
Leather: 72 Sq. Ft.

Pillow Upholstery:

Grade A	120
Grade B	155
COM/Grade C	185
Grade D	215
Grade E	245
Grade F	280
Grade G	325
Grade H	365
Grade J	395
Grade K	460
Grade L	550
Grade M	670
Leather I	880
Leather II	1100
Leather III	1320
Leather IV	1540
Leather V	1760
Leather VI	1980

Upholstery Requires (Per Application):

Fabric: 2¾ Yards
Leather: 49½ Sq. Ft.

Total Required

Upholstery: Fabric: 6¾ Yards
Leather: 121½ Sq. Ft.

PLEASE SPECIFY THE FOLLOWING TO ORDER:

<p>MODEL NUMBER</p>	<p>TEXTILES</p> <p>Indicate fabric choice: Seat</p> <p>See options for fabrics at www.hbftextiles.com</p>	<p>TEXTILES</p> <p>Indicate fabric choice: Pillow</p> <p>See options for fabrics at www.hbftextiles.com</p>	<p>FLAMMABILITY</p> <p>Indicate flammability:</p> <p>U = Cal 117 U3 = Cal 133</p>	<p>BASE FINISH</p> <p>Options for metal finish:</p> <p>BL = Black Powder Coat WI = White Powder Coat +\$50 LG = Light Grey Powder Coat +\$50 POL = Polished Chrome +\$200</p>
----------------------------	---	---	--	--

HLD421-012.FabSeat.FabPillow.Flammability.Base Example: HLD421-012.950-88.950-88.U.BL



CITYSCAPE 2.0 MODULAR SEATING

DUAL-SIDE ADD-ON UNIT, THREE SEAT LOUNGE
NO ARMS / NO BACK

Dimensions

Cityscape 2.0 HLD421-013



OH	17½	AH
OW	96	WBA
OD	28½	DED
SH	17½	DEW
SD	28½	R

Shipping Weight	117
Cube	50.7

Dual-Side Add-On Unit | Three Seat Lounge | No Arms | No Back | Pillow | Fully Upholstered | Black Powder Coat Base | Pillow Clips

Note: To be used in a shared application with freestanding modular seating unit HLD421-023.

LEVEL® Certified
SCS Indoor Advantage™ Certified

Configuration Note: Cannot be stand alone model and must be attached back-to-back with HLD421-023.

Dual-sided seating cannot attach to the pentagons.

Dual-sided seating cannot attach to another dual-sided seating configuration unless connecting table models are added in between. Model HTD42101-5931, HTD42102-5931 or HTD42103-5931 must go in between.

Pricing for Single Fabric Placement:

Upholstery:

Grade A	2855
Grade B	2955
COM/Grade C	3055
Grade D	3155
Grade E	3255
Grade F	3375
Grade G	3515
Grade H	3655
Grade J	3755
Grade K	3955
Grade L	4255
Grade M	4655
Leather I	5335
Leather II	6055
Leather III	6775
Leather IV	7495
Leather V	8215
Leather VI	8935

Upholstery Requires:

Fabric: 9 Yards
Leather: 162 Sq. Ft.

To calculate price, begin with Grade A Single Fabric Pricing on the left, and add the following upcharges for Multiple Fabric Placement Options:

Seat Upholstery:

Grade A	235
Grade B	290
COM/Grade C	350
Grade D	410
Grade E	465
Grade F	535
Grade G	620
Grade H	700
Grade J	760
Grade K	875
Grade L	1050
Grade M	1285
Leather I	1680
Leather II	2100
Leather III	2520
Leather IV	2940
Leather V	3360
Leather VI	3780

Upholstery Requires (Per Application):

Fabric: 5¼ Yards
Leather: 94½ Sq. Ft.

Pillow Upholstery:

Grade A	165
Grade B	210
COM/Grade C	250
Grade D	290
Grade E	335
Grade F	385
Grade G	440
Grade H	500
Grade J	540
Grade K	625
Grade L	750
Grade M	915
Leather I	1200
Leather II	1500
Leather III	1800
Leather IV	2100
Leather V	2400
Leather VI	2700

Upholstery Requires (Per Application):

Fabric: 3¾ Yards
Leather: 67½ Sq. Ft.

Total Required

Upholstery: Fabric: 9 Yards
Leather: 162 Sq. Ft.

PLEASE SPECIFY THE FOLLOWING TO ORDER:

<p>MODEL NUMBER</p>	<p>TEXTILES</p> <p>Indicate fabric choice: Seat</p> <p>See options for fabrics at www.hbftextiles.com</p>	<p>TEXTILES</p> <p>Indicate fabric choice: Pillow</p> <p>See options for fabrics at www.hbftextiles.com</p>	<p>FLAMMABILITY</p> <p>Indicate flammability:</p> <p>U = Cal 117 U3 = Cal 133</p>	<p>BASE FINISH</p> <p>Options for metal finish:</p> <p>BL = Black Powder Coat WI = White Powder Coat +\$50 LG = Light Grey Powder Coat +\$50 POL = Polished Chrome +\$200</p>
----------------------------	---	---	--	--

HLD421-013.FabSeat.FabPillow.Flammability.Base Example: HLD421-013.950-88.950-88.U.BL



Dimensions

Cityscape 2.0 HLD421-024



OH	31½	AH	
OW	57	SW	48
OD	41	DED	
SH	17½	DEW	
SD	31	R	
Shipping Weight		92	
Cube		63.6	

Pentagon Chaise Lounge | No Arms | With LSF Back | Pillow | Fully Upholstered | Black Powder Coat Base

LEVEL® Certified
SCS Indoor Advantage™ Certified

Configuration Notes: Can be stand alone model.

Dual-sided seating cannot attach to the pentagons.

Pricing for Single Fabric Placement:

Upholstery:

Grade A	2460
Grade B	2530
COM/Grade C	2595
Grade D	2660
Grade E	2730
Grade F	2810
Grade G	2900
Grade H	2995
Grade J	3060
Grade K	3195
Grade L	3395
Grade M	3660
Leather I	4115
Leather II	4595
Leather III	5075
Leather IV	5555
Leather V	6035
Leather VI	6515

Upholstery Requires:

Fabric: 6 Yards
Leather: 108 Sq. Ft.

To calculate price, begin with Grade A Single Fabric Pricing on the left, and add the following upcharges for Multiple Fabric Placement Options:

Back Upholstery:

Grade A	65
Grade B	85
COM/Grade C	100
Grade D	115
Grade E	135
Grade F	155
Grade G	175
Grade H	200
Grade J	215
Grade K	250
Grade L	300
Grade M	365
Leather I	480
Leather II	600
Leather III	720
Leather IV	840
Leather V	960
Leather VI	1080

Upholstery Requires (Per Application):

Fabric: 1½ Yards
Leather: 27 Sq. Ft.

Seat Upholstery:

Grade A	135
Grade B	165
COM/Grade C	200
Grade D	235
Grade E	265
Grade F	305
Grade G	355
Grade H	400
Grade J	435
Grade K	500
Grade L	600
Grade M	735
Leather I	960
Leather II	1200
Leather III	1440
Leather IV	1680
Leather V	1920
Leather VI	2160

Upholstery Requires (Per Application):

Fabric: 3 Yards
Leather: 54 Sq. Ft.

Pillow Upholstery:

Grade A	65
Grade B	85
COM/Grade C	100
Grade D	115
Grade E	135
Grade F	155
Grade G	175
Grade H	200
Grade J	215
Grade K	250
Grade L	300
Grade M	365
Leather I	480
Leather II	600
Leather III	720
Leather IV	840
Leather V	960
Leather VI	1080

Upholstery Requires (Per Application):

Fabric: 1½ Yard
Leather: 27 Sq. Ft.

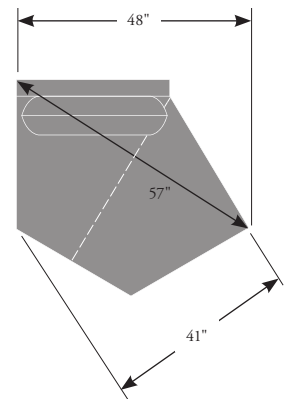

Total Required

Upholstery: Fabric: 6 Yards
Leather: 108 Sq. Ft.

PLEASE SPECIFY THE FOLLOWING TO ORDER:

<p>MODEL NUMBER</p>	<p>TEXTILES</p> <p>Indicate fabric choice: Back</p> <p><i>See options for fabrics at www.hbftextiles.com</i></p>	<p>TEXTILES</p> <p>Indicate fabric choice: Seat</p> <p><i>See options for fabrics at www.hbftextiles.com</i></p>	<p>TEXTILES</p> <p>Indicate fabric choice: Pillow</p> <p><i>See options for fabrics at www.hbftextiles.com</i></p>	<p>FLAMMABILITY</p> <p>Indicate flammability:</p> <p>U = Cal 117 U3 = Cal 133</p>	<p>BASE FINISH</p> <p>Options for metal finish:</p> <p>BL = Black Powder Coat WI = White Powder Coat +\$50 LG = Light Grey Powder Coat +\$50 POL = Polished Chrome +\$200</p>
----------------------------	--	--	--	--	--

HLD421-024.FabBack.FabSeat.FabPillow.Flammability.Base Example: HLD421-024.950-88.950-88.950-88.U.BL



Dimensions

Cityscape 2.0 HLD421-034



OH	31½	AH	
OW	57	SW	48
OD	41	DED	
SH	17½	DEW	
SD	31	R	
Shipping Weight		92	
Cube		63.6	

Pentagon Chaise Lounge | No Arms | With RSF Back | Pillow | Fully Upholstered | Black Powder Coat Base

LEVEL® Certified
SCS Indoor Advantage™ Certified

Configuration Notes: Can be stand alone model.

Dual-sided seating cannot attach to the pentagons.

Pricing for Single Fabric Placement:

Upholstery:

Grade A	2460
Grade B	2530
COM/Grade C	2595
Grade D	2660
Grade E	2730
Grade F	2810
Grade G	2900
Grade H	2995
Grade J	3060
Grade K	3195
Grade L	3395
Grade M	3660
Leather I	4115
Leather II	4595
Leather III	5075
Leather IV	5555
Leather V	6035
Leather VI	6515

Upholstery Requires:

Fabric: 6 Yards
Leather: 108 Sq. Ft.

To calculate price, begin with Grade A Single Fabric Pricing on the left, and add the following upcharges for Multiple Fabric Placement Options:

Back Upholstery:

Grade A	65
Grade B	85
COM/Grade C	100
Grade D	115
Grade E	135
Grade F	155
Grade G	175
Grade H	200
Grade J	215
Grade K	250
Grade L	300
Grade M	365
Leather I	480
Leather II	600
Leather III	720
Leather IV	840
Leather V	960
Leather VI	1080

Upholstery Requires (Per Application):

Fabric: 1½ Yards
Leather: 27 Sq. Ft.

Seat Upholstery:

Grade A	135
Grade B	165
COM/Grade C	200
Grade D	235
Grade E	265
Grade F	305
Grade G	355
Grade H	400
Grade J	435
Grade K	500
Grade L	600
Grade M	735
Leather I	960
Leather II	1200
Leather III	1440
Leather IV	1680
Leather V	1920
Leather VI	2160

Upholstery Requires (Per Application):

Fabric: 3 Yards
Leather: 54 Sq. Ft.

Pillow Upholstery:

Grade A	65
Grade B	85
COM/Grade C	100
Grade D	115
Grade E	135
Grade F	155
Grade G	175
Grade H	200
Grade J	215
Grade K	250
Grade L	300
Grade M	365
Leather I	480
Leather II	600
Leather III	720
Leather IV	840
Leather V	960
Leather VI	1080

Upholstery Requires (Per Application):

Fabric: 1½ Yard
Leather: 27 Sq. Ft.

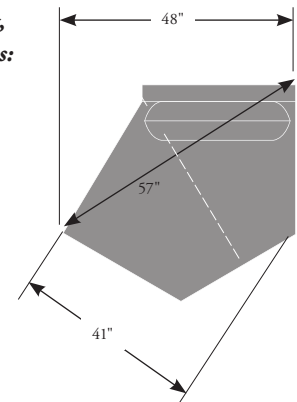

Total Required

Upholstery: Fabric: 6 Yards
Leather: 108 Sq. Ft.

PLEASE SPECIFY THE FOLLOWING TO ORDER:

<p>MODEL NUMBER</p>	<p>TEXTILES</p> <p>Indicate fabric choice: Back</p> <p><i>See options for fabrics at www.hbftextiles.com</i></p>	<p>TEXTILES</p> <p>Indicate fabric choice: Seat</p> <p><i>See options for fabrics at www.hbftextiles.com</i></p>	<p>TEXTILES</p> <p>Indicate fabric choice: Pillow</p> <p><i>See options for fabrics at www.hbftextiles.com</i></p>	<p>FLAMMABILITY</p> <p>Indicate flammability:</p> <p>U = Cal 117 U3 = Cal 133</p>	<p>BASE FINISH</p> <p>Options for metal finish:</p> <p>BL = Black Powder Coat WI = White Powder Coat +\$50 LG = Light Grey Powder Coat +\$50 POL = Polished Chrome +\$200</p>
----------------------------	--	--	--	--	--

HLD421-034.FabBack.FabSeat.FabPillow.Flammability.Base Example: HLD421-034.950-88.950-88.950-88.U.BL



Dimensions

Cityscape 2.0 HLD421-041

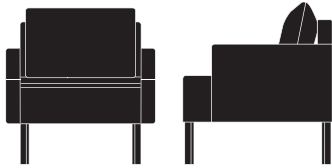

OH	32	AH	23
OW	30	WBA	24
OD	30	DED	
SH	17½	DEW	
SD	19½	R	

Shipping Weight 70
Cube 20.2

Armchair | Pillow | Fully Upholstered | Black Powder Coat Base

LEVEL® Certified
SCS Indoor Advantage™ Certified

Configuration Notes: Stand alone model only and does not attach

Pricing for Single Fabric Placement:

To calculate price, begin with Grade A Single Fabric Pricing on the left, and add the following upcharges for Multiple Fabric Placement Options:

Upholstery:	Back Upholstery:	Arm Upholstery:	Seat Upholstery:	Pillow Upholstery:
Grade A 2915	Grade A 65	Grade A 90	Grade A 80	Grade A 65
Grade B 2990	Grade B 85	Grade B 110	Grade B 95	Grade B 85
COM/Grade C 3065	COM/Grade C 100	COM/Grade C 135	COM/Grade C 115	COM/Grade C 100
Grade D 3135	Grade D 115	Grade D 155	Grade D 135	Grade D 115
Grade E 3220	Grade E 135	Grade E 180	Grade E 155	Grade E 135
Grade F 3310	Grade F 155	Grade F 205	Grade F 180	Grade F 155
Grade G 3405	Grade G 175	Grade G 235	Grade G 205	Grade G 175
Grade H 3515	Grade H 200	Grade H 265	Grade H 235	Grade H 200
Grade J 3590	Grade J 215	Grade J 290	Grade J 255	Grade J 215
Grade K 3740	Grade K 250	Grade K 335	Grade K 290	Grade K 250
Grade L 3965	Grade L 300	Grade L 400	Grade L 350	Grade L 300
Grade M 4265	Grade M 365	Grade M 490	Grade M 430	Grade M 365
Leather I 4775	Leather I 480	Leather I 640	Leather I 560	Leather I 480
Leather II 5315	Leather II 600	Leather II 800	Leather II 700	Leather II 600
Leather III 5855	Leather III 720	Leather III 960	Leather III 840	Leather III 720
Leather IV 6395	Leather IV 840	Leather IV 1120	Leather IV 980	Leather IV 840
Leather V 6935	Leather V 960	Leather V 1280	Leather V 1120	Leather V 960
Leather VI 7475	Leather VI 1080	Leather VI 1440	Leather VI 1260	Leather VI 1080
Upholstery Requires:	Upholstery Requires (Per Application):	Upholstery Requires (Per Application):	Upholstery Requires (Per Application):	Upholstery Requires (Per Application):

Fabric: 6¾ Yards
Leather: 121½ Sq. Ft.

Fabric: 1½ Yards
Leather: 27 Sq. Ft.

Fabric: 2 Yards
Leather: 36 Sq. Ft.

Fabric: 1¾ Yard
Leather: 31½ Sq. Ft.

Fabric: 1½ Yard
Leather: 27 Sq. Ft.

Total Required Upholstery: Fabric: 6¾ Yards
Leather: 121½ Sq. Ft.

PLEASE SPECIFY THE FOLLOWING TO ORDER:

MODEL NUMBER	TEXTILES	TEXTILES	TEXTILES	TEXTILES	FLAMMABILITY	BASE FINISH
	Indicate fabric choice: Back	Indicate fabric choice: Arm	Indicate fabric choice: Seat	Indicate fabric choice: Pillow	Indicate flammability:	Options for metal finish:
	See options for fabrics at www.hbf textiles.com	See options for fabrics at www.hbf textiles.com	See options for fabrics at www.hbf textiles.com	See options for fabrics at www.hbf textiles.com	U = Cal 117 U3 = Cal 133	BL = Black Powder Coat WI = White Powder Coat +\$50 LG = Light Grey Powder Coat +\$50 POL = Polished Chrome +\$200

HLD421-041.FabBack.FabArm.FabSeat.FabPillow.Flammability.Base Example: HLD421-041.950-88.950-88.950-88.950-88.U.BL



Dimensions

Cityscape 2.0 HLD421-042



OH	32	AH	23
OW	54	WBA	48
OD	30	DED	
SH	17½	DEW	
SD	19½	R	

Shipping Weight 110
Cube 33

LEVEL® Certified
SCS Indoor Advantage™ Certified

Two Seat Sofa | Pillow | Fully Upholstered | Black Powder Coat Base

Configuration Notes: Stand alone model only and does not attach

Pricing for Single Fabric Placement:

To calculate price, begin with Grade A Single Fabric Pricing on the left, and add the following upcharges for Multiple Fabric Placement Options:

Upholstery:	Back Upholstery:	Arm Upholstery:	Seat Upholstery:	Pillow Upholstery:
Grade A 3945	Grade A 100	Grade A 90	Grade A 110	Grade A 80
Grade B 4035	Grade B 125	Grade B 110	Grade B 140	Grade B 95
COM/Grade C 4130	COM/Grade C 150	COM/Grade C 135	COM/Grade C 165	COM/Grade C 115
Grade D 4225	Grade D 175	Grade D 155	Grade D 195	Grade D 135
Grade E 4320	Grade E 200	Grade E 180	Grade E 220	Grade E 155
Grade F 4435	Grade F 230	Grade F 205	Grade F 255	Grade F 180
Grade G 4565	Grade G 265	Grade G 235	Grade G 295	Grade G 205
Grade H 4700	Grade H 300	Grade H 265	Grade H 335	Grade H 235
Grade J 4795	Grade J 325	Grade J 290	Grade J 360	Grade J 255
Grade K 4980	Grade K 375	Grade K 335	Grade K 415	Grade K 290
Grade L 5265	Grade L 450	Grade L 400	Grade L 500	Grade L 350
Grade M 5645	Grade M 550	Grade M 490	Grade M 610	Grade M 430
Leather I 6285	Leather I 720	Leather I 640	Leather I 800	Leather I 560
Leather II 6965	Leather II 900	Leather II 800	Leather II 1000	Leather II 700
Leather III 7645	Leather III 1080	Leather III 960	Leather III 1200	Leather III 840
Leather IV 8325	Leather IV 1260	Leather IV 1120	Leather IV 1400	Leather IV 980
Leather V 9005	Leather V 1440	Leather V 1280	Leather V 1600	Leather V 1120
Leather VI 9685	Leather VI 1620	Leather VI 1440	Leather VI 1800	Leather VI 1260
Upholstery Requires:	Upholstery Requires (Per Application):	Upholstery Requires (Per Application):	Upholstery Requires (Per Application):	Upholstery Requires (Per Application):
Fabric: 8½ Yards Leather: 153 Sq. Ft.	Fabric: 2¼ Yards Leather: 40½ Sq. Ft.	Fabric: 2 Yards Leather: 36 Sq. Ft.	Fabric: 2½ Yard Leather: 45 Sq. Ft.	Fabric: 1¾ Yard Leather: 31½ Sq. Ft.

Total Required

Upholstery: Fabric: 8½ Yards
Leather: 153 Sq. Ft.

PLEASE SPECIFY THE FOLLOWING TO ORDER:

MODEL NUMBER	TEXTILES	TEXTILES	TEXTILES	TEXTILES	FLAMMABILITY	BASE FINISH
	Indicate fabric choice: Back	Indicate fabric choice: Arm	Indicate fabric choice: Seat	Indicate fabric choice: Pillow	Indicate flammability:	Options for metal finish:
	See options for fabrics at www.hbf textiles.com	See options for fabrics at www.hbf textiles.com	See options for fabrics at www.hbf textiles.com	See options for fabrics at www.hbf textiles.com	U = Cal 117 U3 = Cal 133	BL = Black Powder Coat WI = White Powder Coat +\$50 LG = Light Grey Powder Coat +\$50 POL = Polished Chrome +\$200

HLD421-042.FabBack.FabArm.FabSeat.FabPillow.Flammability.Base Example: HLD421-042.950-88.950-88.950-88.950-88.U.BL



Dimensions

Cityscape 2.0 HLD421-043



OH	32	AH	23
OW	78	WBA	72
OD	30	DED	
SH	17½	DEW	
SD	19½	R	

Shipping Weight 142
Cube 48

LEVEL® Certified
SCS Indoor Advantage™ Certified

Three Seat Sofa | Pillow | Fully Upholstered | Black Powder Coat Base

Configuration Notes: Stand alone model only and does not attach

Pricing for Single Fabric Placement:

To calculate price, begin with Grade A Single Fabric Pricing on the left, and add the following upcharges for Multiple Fabric Placement Options:

Upholstery:	Back Upholstery:	Arm Upholstery:	Seat Upholstery:	Pillow Upholstery:
Grade A 4825	Grade A 145	Grade A 90	Grade A 210	Grade A 100
Grade B 4960	Grade B 180	Grade B 110	Grade B 265	Grade B 125
COM/Grade C 5095	COM/Grade C 215	COM/Grade C 135	COM/Grade C 315	COM/Grade C 150
Grade D 5235	Grade D 255	Grade D 155	Grade D 370	Grade D 175
Grade E 5370	Grade E 290	Grade E 180	Grade E 420	Grade E 200
Grade F 5530	Grade F 330	Grade F 205	Grade F 485	Grade F 230
Grade G 5725	Grade G 385	Grade G 235	Grade G 560	Grade G 265
Grade H 5915	Grade H 435	Grade H 265	Grade H 635	Grade H 300
Grade J 6050	Grade J 470	Grade J 290	Grade J 685	Grade J 325
Grade K 6320	Grade K 540	Grade K 335	Grade K 790	Grade K 375
Grade L 6730	Grade L 650	Grade L 400	Grade L 950	Grade L 450
Grade M 7275	Grade M 795	Grade M 490	Grade M 1160	Grade M 550
Leather I 8200	Leather I 1040	Leather I 640	Leather I 1520	Leather I 720
Leather II 9180	Leather II 1300	Leather II 800	Leather II 1900	Leather II 900
Leather III 10,160	Leather III 1560	Leather III 960	Leather III 2280	Leather III 1080
Leather IV 11,140	Leather IV 1820	Leather IV 1120	Leather IV 2660	Leather IV 1260
Leather V 12,120	Leather V 2080	Leather V 1280	Leather V 3040	Leather V 1440
Leather VI 13,100	Leather VI 2340	Leather VI 1440	Leather VI 3420	Leather VI 1620
Upholstery Requires:	Upholstery Requires (Per Application):	Upholstery Requires (Per Application):	Upholstery Requires (Per Application):	Upholstery Requires (Per Application):
Fabric: 12¼ Yards Leather: 220½ Sq. Ft.	Fabric: 3¼ Yards Leather: 58½ Sq. Ft.	Fabric: 2 Yards Leather: 36 Sq. Ft.	Fabric: 4¾ Yard Leather: 85½ Sq. Ft.	Fabric: 2¼ Yard Leather: 40½ Sq. Ft.



Total Required Upholstery: Fabric: 12¼ Yards
Leather: 220½ Sq. Ft.

PLEASE SPECIFY THE FOLLOWING TO ORDER:

MODEL NUMBER	TEXTILES	TEXTILES	TEXTILES	TEXTILES	FLAMMABILITY	BASE FINISH
	Indicate fabric choice: Back	Indicate fabric choice: Arm	Indicate fabric choice: Seat	Indicate fabric choice: Pillow	Indicate flammability:	Options for metal finish:
	See options for fabrics at www.hbf textiles.com	See options for fabrics at www.hbf textiles.com	See options for fabrics at www.hbf textiles.com	See options for fabrics at www.hbf textiles.com	U = Cal 117 U3 = Cal 133	BL = Black Powder Coat WI = White Powder Coat +\$50 LG = Light Grey Powder Coat +\$50 POL = Polished Chrome +\$200

HLD421-043.FabBack.FabArm.FabSeat.FabPillow.Flammability.Base Example: HLD421-043.950-88.950-88.950-88.950-88.U.BL

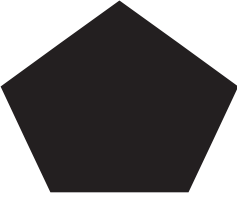

	List Prices			Sq.Ft.	Yards	Dimensions					
Cityscape 2.0 HLD421-014											
	Grade A	2200	Grade G	2420	54	3	OH	17½	AH		
	Grade B	2230	Grade H	2465			OW	57	WBA		
	COM/Grade C	2265	Grade J	2500			OD	41	DED		
	Grade D	2300	Grade K	2565			Leather IV	3745	SH	17½	DEW
	Grade E	2330	Grade L	2665			Leather V	3985	SD	41	R
	Grade F	2370	Grade M	2800			Leather VI	4225	Shipping Weight		70
									Cube		31
											

Pentagon Ottoman | No Arms | No Back | Fully Upholstered | Black Powder Coat Base

LEVEL[®] Certified
SCS Indoor Advantage[™] Certified

*Configuration Notes: Can be stand alone model.
Dual-sided seating cannot attach to the pentagons.*

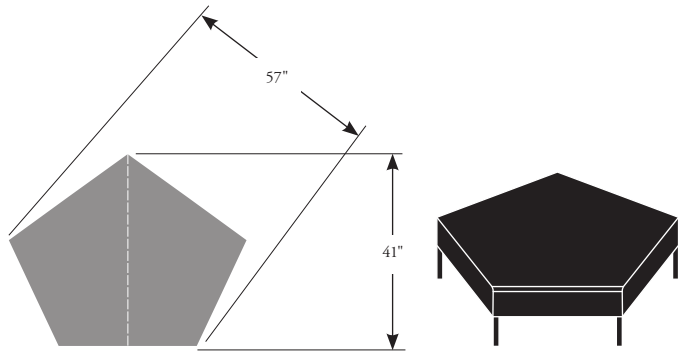



PLEASE SPECIFY THE FOLLOWING TO ORDER:

MODEL NUMBER	TEXTILES	FLAMMABILITY	BASE FINISH
	Indicate fabric choice: Seat <i>See options for fabrics at www.hbf textiles.com</i>	Indicate flammability: <ul style="list-style-type: none"> <input type="checkbox"/> U = Cal 117 <input type="checkbox"/> U3 = Cal 133 	Options for metal finish: <ul style="list-style-type: none"> <input type="checkbox"/> BL = Black Powder Coat <input type="checkbox"/> WI = White Powder Coat +\$50 <input type="checkbox"/> LG = Light Grey Powder Coat +\$50 <input type="checkbox"/> POL = Polished Chrome +\$200

HLD421-014.FabSeat.Flammability.Base Example: HLD421-014.950-88.U.BL



	List Prices			Sq.Ft.	Yards	Dimensions					
Cityscape 2.0 HLD421-044											
 	Grade A	1595	Grade G	1885	72	4	OH	17½	AH		
	Grade B	1635	Grade H	1950			OW	24	WBA		
	COM/Grade C	1680	Grade J	1995			OD	24	DED		
	Grade D	1725	Grade K	2080			Leather IV	3655	SH	17½	DEW
	Grade E	1770	Grade L	2215			Leather V	3975	SD	24	R
	Grade F	1825	Grade M	2395			Leather VI	4295	Shipping Weight		35
									Cube		16

Square Ottoman | No Arms | No Back | Fully Upholstered | Black Powder Coat Base

LEVEL[®] Certified
SCS Indoor Advantage[™] Certified

Configuration Notes: Stand alone model only and does not attach

PLEASE SPECIFY THE FOLLOWING TO ORDER:

MODEL NUMBER	TEXTILES	FLAMMABILITY	BASE FINISH
	Indicate fabric choice: Seat <i>See options for fabrics at www.hbftextiles.com</i>	Indicate flammability: U = Cal 117 U3 = Cal 133	Options for metal finish: BL = Black Powder Coat WI = White Powder Coat +\$50 LG = Light Grey Powder Coat +\$50 POL = Polished Chrome +\$200

HLD421-044.FabSeat.Flammability.Base Example: HLD421-044.950-88.U.BL



Style Number	Description	List Price	Shipping Weight	Cube
Cityscape 2.0 Ganging Leg Kit				
HAD421-010	Bracket Kit	475		

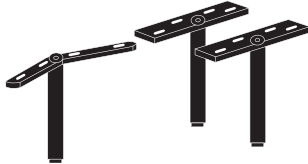

Note: Depending on configuration, all ganging legs may not be used.



Cityscape 2.0 Modular Connecting Tables Specifications

Surface	Laminate
Metal	Black Powder Coat Light Grey Powder Coat White Powder Coat Polished Chrome
Power Data Options	Available

Power Options (1 Power Receptacle and 1 USB-2 amps per port)



HVD71901N-110
Black Powder Coat,
Black Simplex



HVD71902N-110
White Powder Coat,
White Simplex



HVD71903N-110
Trichrome
Black Simplex



HVD71904N-110
Trichrome
White Simplex

CITYSCAPE 2.0 Power Location(s)

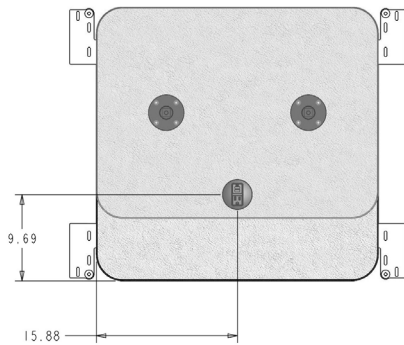

HTD42102-3231

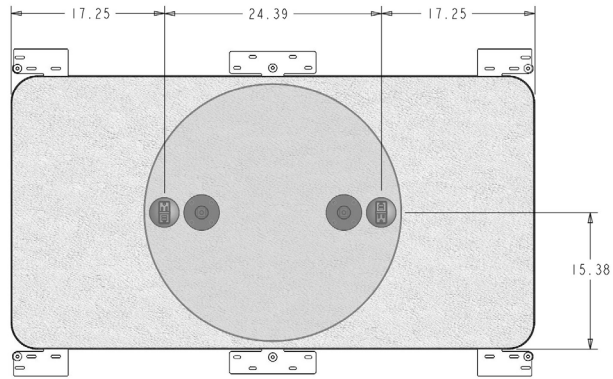

HTD42102-5931 with One Power Location
HTD42103-5931 with Two Power Locations

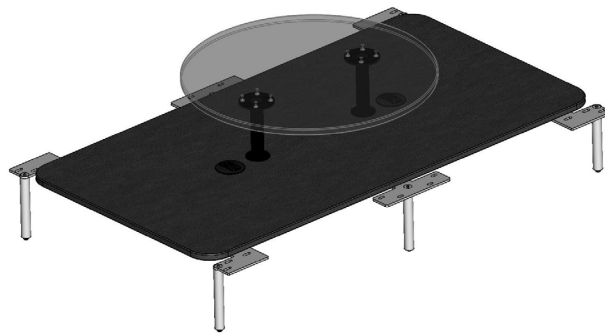



Cityscape 2.0 Modular Rectangular Connecting Table

Style Number	Top Description	List Price	Two Tables per Set	Shipping Weight	Cube
HTD42101-3231	Laminate	1,955	Top: W 31¾ D 23¾ H 8½ Bottom: W 31¾ D 30¾ H 22½ Overall Height: 31	64	10.79

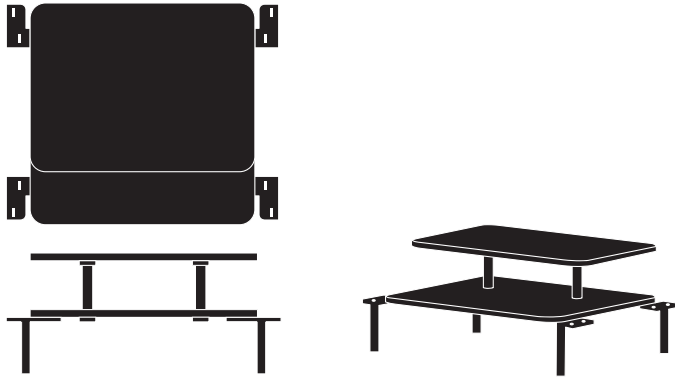

Rectangular Top Table | Rectangular Bottom Table | Black Powder Coated Legs

LEVEL® Certification
SCS Indoor Advantage™ Certification

Configuration Notes: Connecting tables cannot be set up as a standalone model or configured on an end of seating row.

Dual-sided seating cannot attach to another dual-sided seating configuration unless connecting table models are added in between. Model HTD42101-5931, HTD42102-5931 or HTD42103-5931 must go in between.

PLEASE SPECIFY THE FOLLOWING TO ORDER: _____

MODEL NUMBER	TOP	BASE FINISH
	Options for laminate finishes: PL = Laminat 7943 = Columbian Walnut 7965 = Walnut Heights 8238 = Fairchild BW = Beigewood DW1 = Designer White M11 = Loft Grey Cloud M16 = Flint PT1 = Portico Teak	Options for metal leg finish: BL = Black Powder Coat W1 = White Powder Coat +\$50 LG = Light Grey Powder Coat +\$50 POL = Polished Chrome +\$200

HTD42101-3231.Top.Base Example: HTD42101-3231.PLBW.BL



Cityscape 2.0 Modular Rectangular Connecting Table with Round Top

Style Number	Top Description	List Price	Two Tables per Set	Shipping Weight	Cube
HTD42101-5931	Laminate	1,985	Top: Dia 29 H 8½ Bottom: W 58¾ D 30¾ H 22½ Overall Height: 31	92	18.67

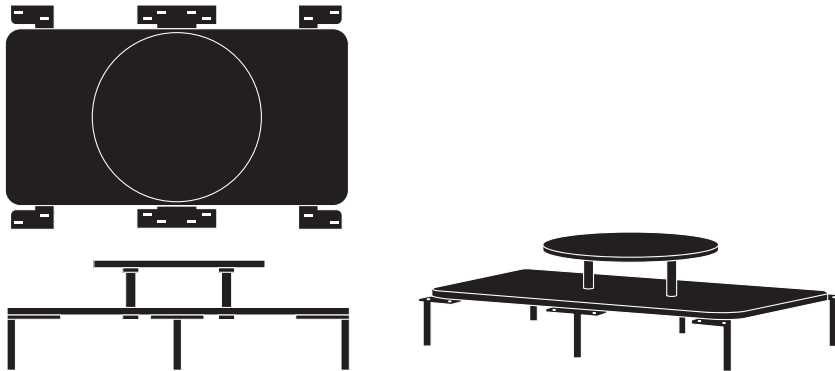

Round Top Table | Rectangular Bottom Table | Black Powder Coated Legs

LEVEL® Certification
SCS Indoor Advantage™ Certification

Configuration Notes: Connecting tables cannot be set up as a standalone model or configured on an end of seating row.

Dual-sided seating cannot attach to another dual-sided seating configuration unless connecting table models are added in between. Model HTD42101-5931, HTD42102-5931 or HTD42103-5931 must go in between.

PLEASE SPECIFY THE FOLLOWING TO ORDER: _____

MODEL NUMBER	TOP	BASE FINISH
	Options for laminate finishes: PL = Laminate 7943 = Columbian Walnut 7965 = Walnut Heights 8238 = Fairchild BW = Beigewood DW1 = Designer White M11 = Loft Grey Cloud M16 = Flint PT1 = Portico Teak	Options for metal leg finish: BL = Black Powder Coat W1 = White Powder Coat +\$50 LG = Light Grey Powder Coat +\$50 POL = Polished Chrome +\$200

HTD42101-5931.Top.Base Example: HTD42101-5931.PLBW.BL



Cityscape 2.0 Modular Rectangular Connecting Table with Power Capability

Style Number	Top Description	List Price	Two Tables per Set	Shipping Weight	Cube
HTD42102-3231	Laminate	2,060	Top: W 31¾ D 23¾ H 8½ Bottom: W 31¾ D 30¾ H 22½ Overall Height: 31	64	10.79

Note: One powerConnect module must be ordered separately. (see page 37 for power options.)

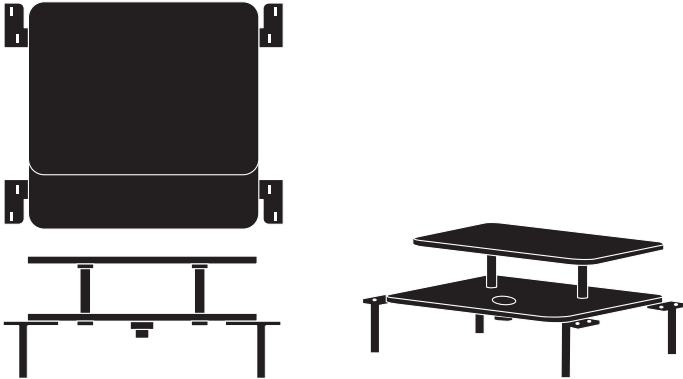

Rectangular Top Table | Rectangular Bottom Table | Black Powder Coated Legs | Power Capability

LEVEL® Certification
SCS Indoor Advantage™ Certification

Configuration Notes: Connecting tables cannot be set up as a standalone model or configured on an end of seating row.

Dual-sided seating cannot attach to another dual-sided seating configuration unless connecting table models are added in between. Model HTD42101-5931, HTD42102-5931 or HTD42103-5931 must go in between.

PLEASE SPECIFY THE FOLLOWING TO ORDER: _____

MODEL NUMBER	TOP	BASE FINISH
	Options for laminate finishes: PL = Laminate 7943 = Columbian Walnut 7965 = Walnut Heights 8238 = Fairchild BW = Beigewood DW1 = Designer White M11 = Loft Grey Cloud M16 = Flint PT1 = Portico Teak	Options for metal leg finish: BL = Black Powder Coat W1 = White Powder Coat +\$50 LG = Light Grey Powder Coat +\$50 POL = Polished Chrome +\$200

HTD42102-3231.Top.Base Example: HTD42102-3231.PLBW.BL



Cityscape 2.0 Modular Connecting Table with Round Top and Power Capability

Style Number	Top Description	List Price	Two Tables per Set	Shipping Weight	Cube
HTD42102-5931	Laminate	2,090	Top: Dia 29 H 8½ Bottom: W 58¾ D 30¾ H 22½ Overall Height: 31	92	18.67

Note: One powerConnect module must be ordered separately. (see page 37 for power options.)

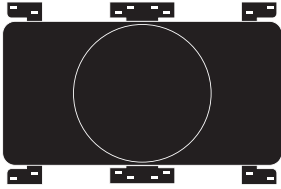

Round Top Table | Rectangular Bottom Table | Black Powder Coated Legs | Power Capability

LEVEL® Certification
SCS Indoor Advantage™ Certification

Configuration Notes: Connecting tables cannot be set up as a standalone model or configured on an end of seating row.

Dual-sided seating cannot attach to another dual-sided seating configuration unless connecting table models are added in between. Model HTD42101-5931, HTD42102-5931 or HTD42103-5931 must go in between.

PLEASE SPECIFY THE FOLLOWING TO ORDER:

MODEL NUMBER	TOP	BASE FINISH
	Options for laminate finishes: PL = Laminate 7943 = Columbian Walnut 7965 = Walnut Heights 8238 = Fairchild BW = Beigewood DW1 = Designer White M11 = Loft Grey Cloud M16 = Flint PT1 = Portico Teak	Options for metal leg finish: BL = Black Powder Coat W1 = White Powder Coat +\$50 LG = Light Grey Powder Coat +\$50 POL = Polished Chrome +\$200

HTD42102-5931.Top.Base Example: HTD42102-5931.PLBW.BL



Cityscape 2.0 Modular Connecting Table with Round Top and Power Capability

Style Number	Top Description	List Price	Two Tables per Set	Shipping Weight	Cube
HTD42103-5931	Laminate	2,195	Top: Dia 29 H 8½ Bottom: W 58¾ D 30¾ H 22½ Overall Height: 31	92	18.67

Note: Two powerConnect modules must be ordered separately. (see page 37 for power options.)

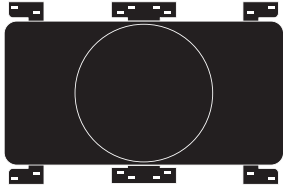

Round Top Table | Rectangular Bottom Table | Black Powder Coated Legs | Power Capability

LEVEL® Certification
SCS Indoor Advantage™ Certification

Configuration Notes: Connecting tables cannot be set up as a standalone model or configured on an end of seating row.

Dual-sided seating cannot attach to another dual-sided seating configuration unless connecting table models are added in between. Model HTD42101-5931, HTD42102-5931 or HTD42103-5931 must go in between.

PLEASE SPECIFY THE FOLLOWING TO ORDER: _____

MODEL NUMBER	TOP	BASE FINISH
	Options for laminate finishes: PL = Laminate 7943 = Columbian Walnut 7965 = Walnut Heights 8238 = Fairchild BW = Beigewood DW1 = Designer White M11 = Loft Grey Cloud M16 = Flint PT1 = Portico Teak	Options for metal leg finish: BL = Black Powder Coat W1 = White Powder Coat +\$50 LG = Light Grey Powder Coat +\$50 POL = Polished Chrome +\$200

HTD42103-5931.Top.Base Example: HTD42103-5931.PLBW.BL



Model	Description	Dimensions Diameter	List Price
POWERCONNECT			
HVD71901N-110	1 receptacle & 1 dual USB; Black powder coat; Black simplex		325
HVD71902N-110	1 receptacle & 1 dual USB; White powder coat; White simplex		325
HVD71903N-110	1 receptacle & 1 dual USB; Trichrome; Black simplex		380
HVD71904N-110	1 receptacle & 1 dual USB; Trichrome; White simplex		350

Power Options (1 Power Receptacle and 1 USB-2 amps per port), 72" cord



HVD71901N-110
Black Powder Coat,
Black Simplex



HVD71902N-110
White Powder Coat,
White Simplex



HVD71903N-110
Trichrome
Black Simplex



HVD71904N-110
Trichrome
White Simplex

CITYSCAPE 2.0 Power Location(s)

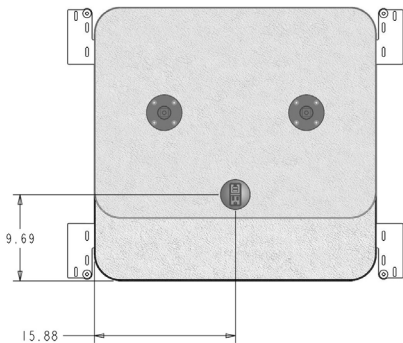

HTD42102-3231

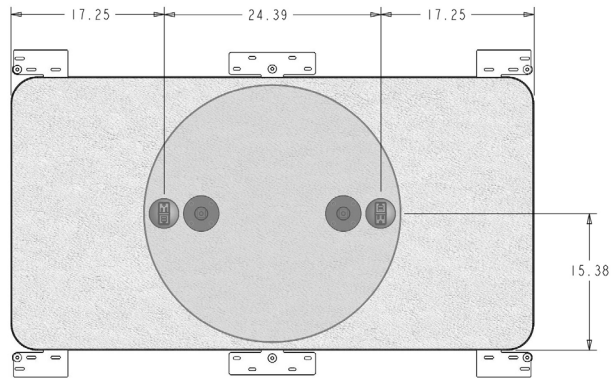

HTD42102-5931 with One Power Location
HTD42103-5931 with Two Power Locations

