

Assembly Instructions

Techport

(Sheet # B1013-0007-00)

Standard Application

Attaching Techport to underside of top, then bezel to Techport

Tools Required

- Phillips head screwdriver

Hardware Required

- See hardware list at end of document

Step 1 Position the Techport assembly under the top per Figure 1, aligning the pilot holes in the top with holes in the mounting brackets. Attach the Techport assembly to the top using the #10x1" screws supplied.

CAUTION: Do not over torque these screws. The maximum torque is 80 in-lbs (9 N-m).

Step 2 Press Bezel Assembly (included with Techport) into top of Techport, aligning spring clips to mating grooves on inner walls so that bezel sits level with top surface, fully seated around the outer edges (see Figure 2).

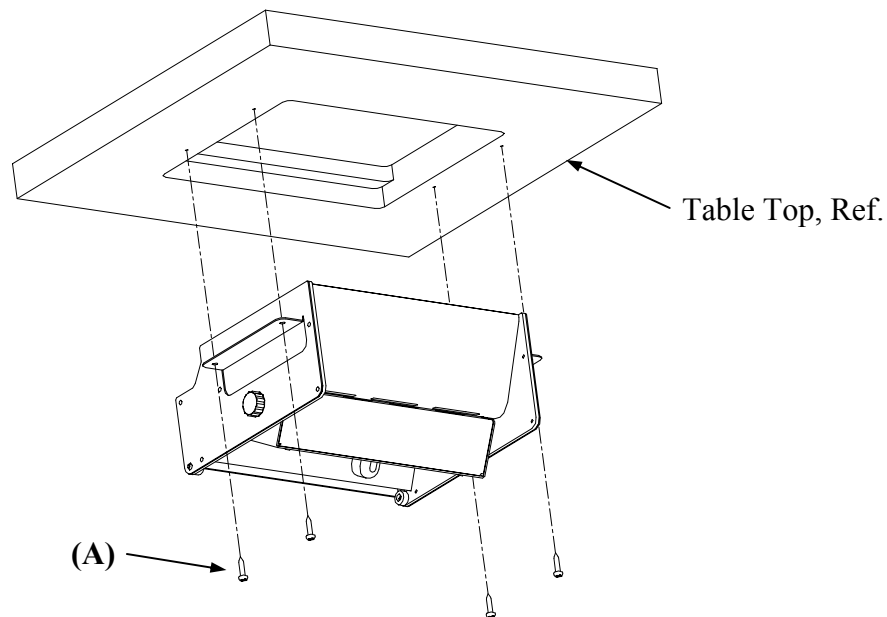

Figure 1: Techport Attachment



900 - 12th STREET DRIVE NW
P.O. BOX 8
HICKORY, NC 28603
TEL: 828.328.2064
FAX: 828.485.2690
HBFSERVICE@HBF.COM

Assembly Instructions
Techport
(Sheet # B1013-0007-00)

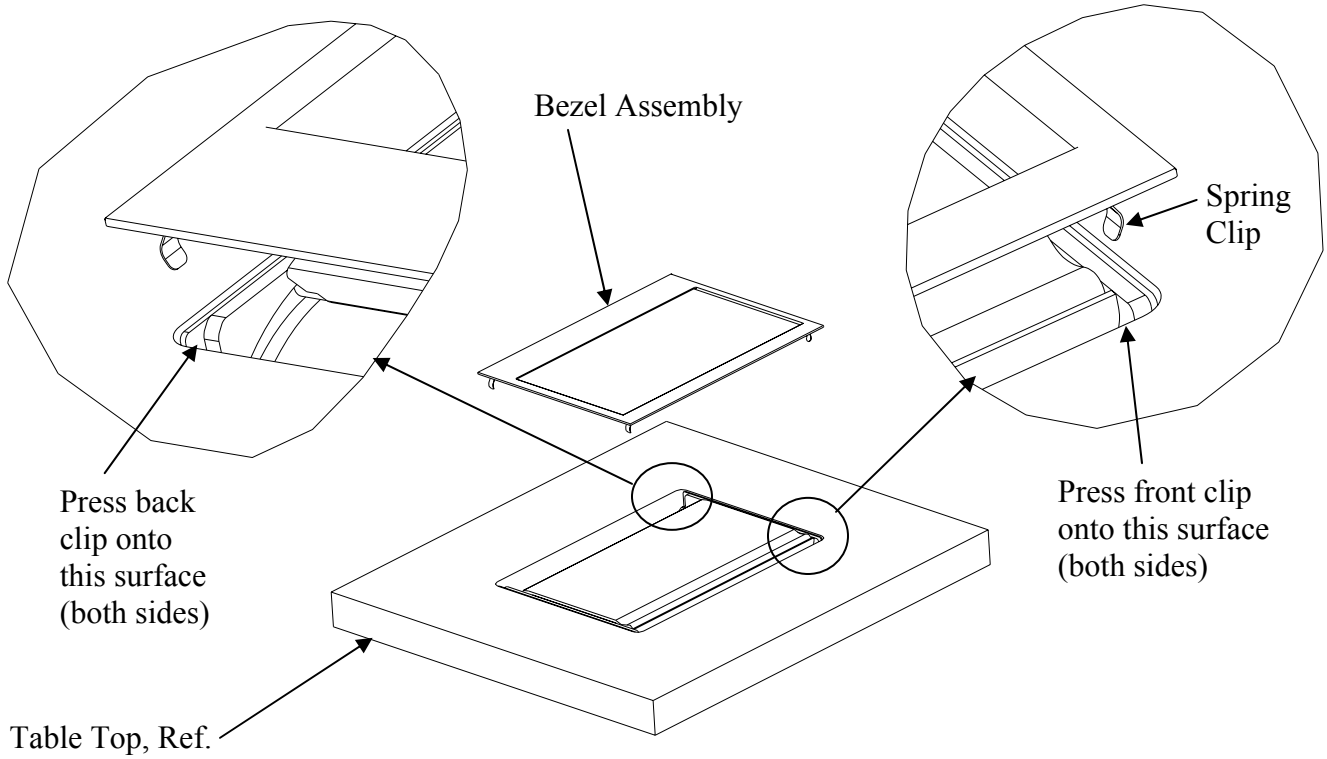

Figure 2: Bezel Assembly Placement



(A)
#10x1" Phillips
Wood Screw

Techport Attachment Hardware (included with Techport Assembly)

Description	Qty.	Gunlocke Part #
Hardware packaged		
#10x1" Phillips Wood Screw	4	19917-4404-35