

HBF Hickory, NC 28601
828.328.2064

ASSEMBLY INSTRUCTIONS

BASE / STRETCHER / AND MODESTY ASSEMBLY INSTRUCTIONS

GENERAL NOTES

- 1.) REPORT DAMAGE BEFORE PROCEEDING.
- 2.) ALWAYS PROTECT THE WORKSURFACE DURING INSTALLATION.
- 3.) ALWAYS LEVEL UNIT AT FINAL LOCATION

ATTACH TABLE BASE

STEP 1) SET ONE BASE ON TOP OF FLIP MECHANISM WITH THE FEET POINTING OUT.

STEP 2) SECURE IN PLACE USING FOUR 1/4-20 X 1" L BLACK MACHINE SCREWS. DO NOT TIGHTEN UNTIL STRETCHER IS SECURED AND TIGHTENED. (LOOK FOR THREAD LOCK PATCH ON SCREW THREADS IF NONE, LIQUID THREAD LOCK SHOULD BE APPLIED TO EACH SCREW)

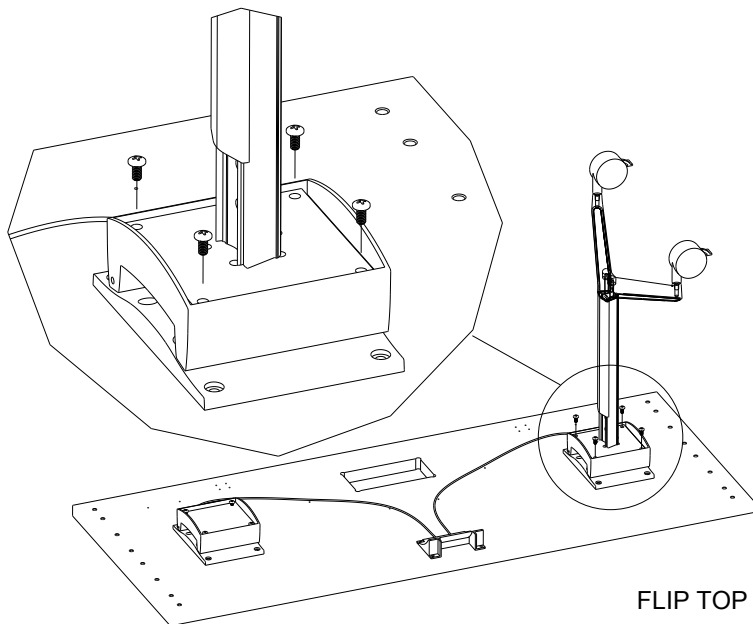

NOTE:

FIXED TOP TABLE BASES FASTEN DIRECTLY TO BOTTOM OF WORKSURFACE USING 1" PANHEAD WOOD SCREWS AND PRE-DRILLED PILOT HOLES

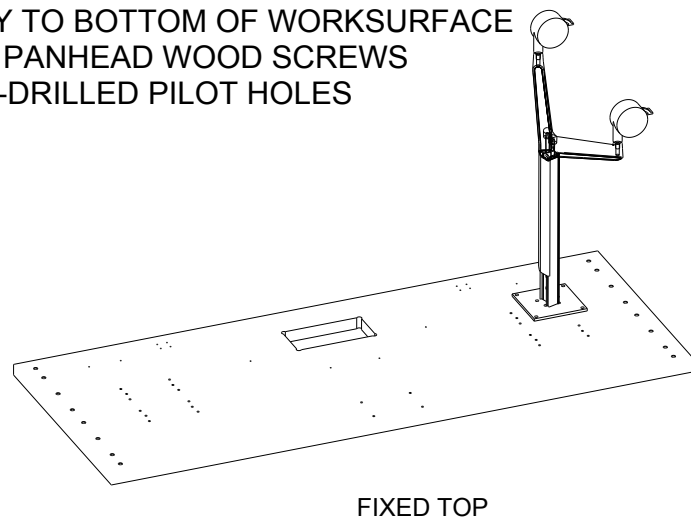

ATTACH WIRE MANAGER EXTRUSION

STEP 3) SLIDE PLASTIC WIRE MANAGER INTO THE END OF THE STRETCHER.

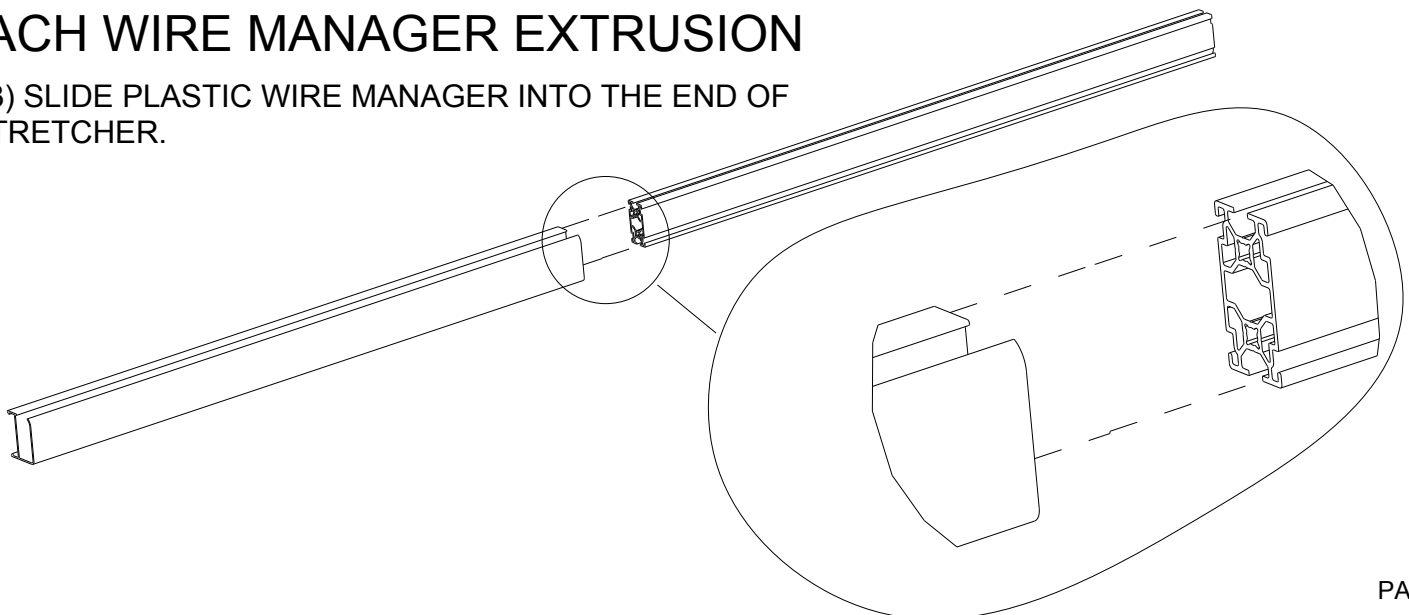

POSITION 2ND BASE AND STRETCHER

STEP 4) SET THE 2ND BASE ON THE OTHER FLIP MECH WITH THE FEET POINTING OUT

STEP 5) PLACE THE STRETCHER IN THE SLOTS BETWEEN THE TWO BASES WITH THE WIRE MANAGER FACING AWAY FROM THE FLIP MECH HANDLE.

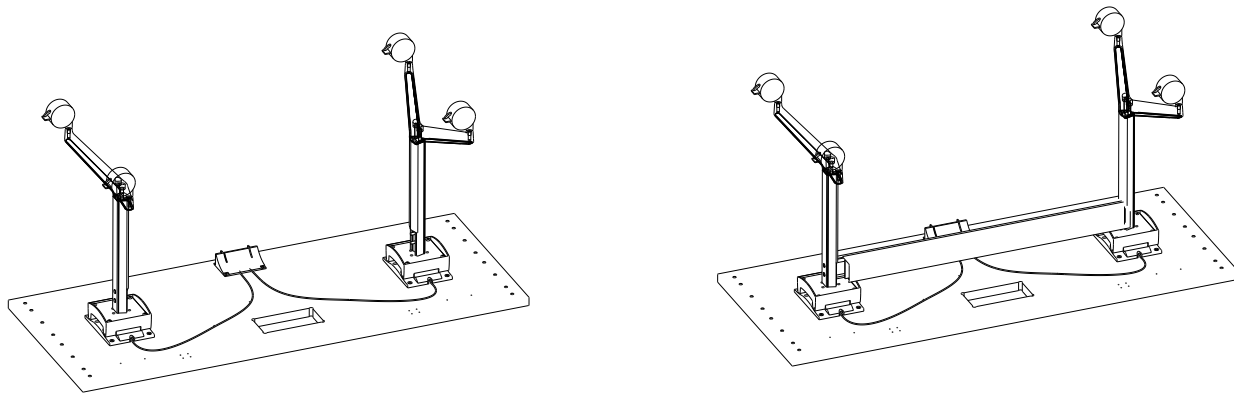

ATTACH 2ND BASE AND STRETCHER

NOTE: ONCE ALL FASTENERS ARE STARTED- THEN PROCEED TO TIGHTEN ALL FASTENERS

STEP 6) SECURE STRETCHER IN PLACE USING FOUR 5/16-18 X1-1/4" L BLACK SOCKET HEAD CAP SCREWS, COVER EACH OF THESE HOLES USING THE CHROME CAP PLUGS

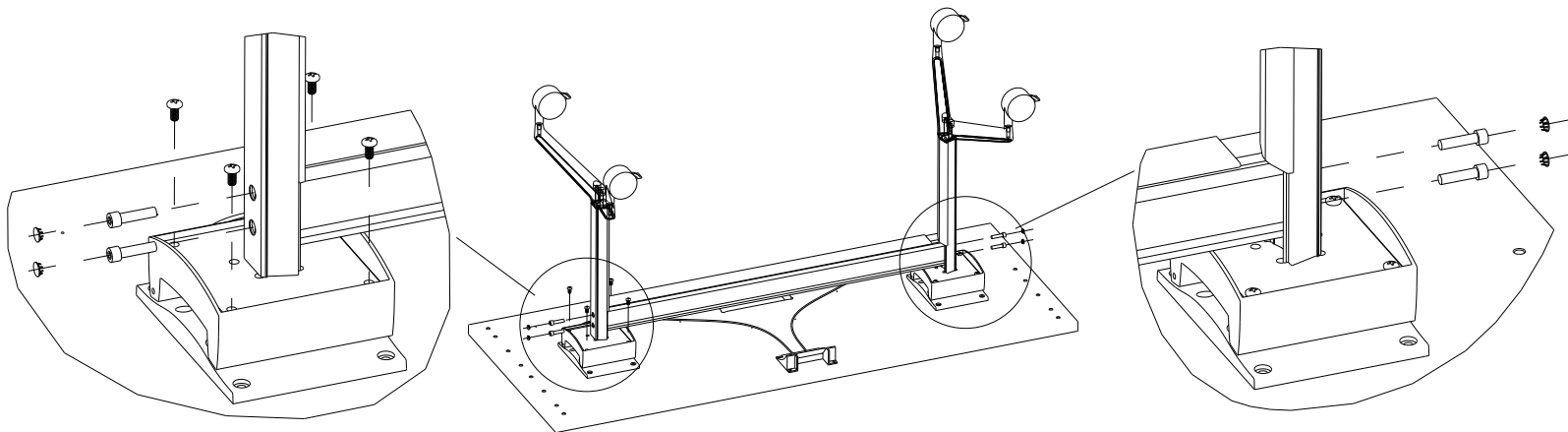

ATTACH (OPTIONAL) MODESTY PANEL TO WORK SURFACE

STEP 7) ATTACH HINGE(S) TO MODESTY PANEL USING (SCREW #10X5/8" L BLACK PAN HEAD) QTY (8) INTO PILOT HOLES PROVIDED, REF. DWG BELOW FOR HINGE ORIENTATION.

STEP 8) ATTACH (HINGES/MODESTY PANEL) TO WORK SURFACE USING (QTY 8) (SCREW #10X5/8" L BLACK PAN HEAD) IN PILOT HOLES PROVIDED.

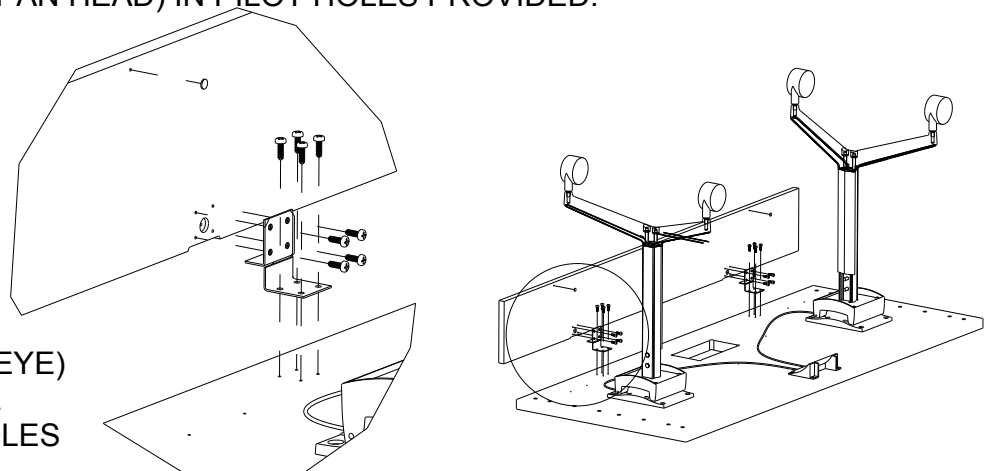

STEP 9) ADD BUMPERS (FISH EYE) TO BACK OF MODESTY PANEL OVER LOCATION OF PILOT HOLES IN TWO LOCATIONS.