



G3306B NA Gas Petroleum Engine

108 kW (145 bhp)
1800 rpm

0.5 g/bhp-hr NOx or 1.0 g/bhp-hr NOx (NTE)

CAT® ENGINE SPECIFICATIONS

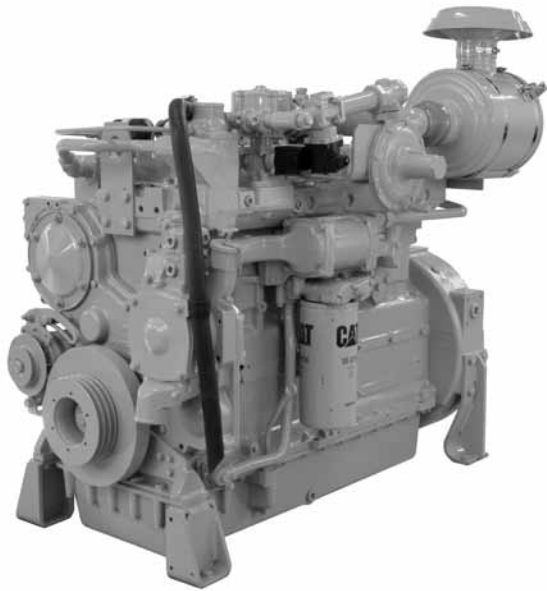

In-Line 6, 4-Stroke-Cycle

Emissions	NSPS 2010
Bore	121 mm (4.8 in)
Stroke	152 mm (6.0 in)
Displacement	10.5 L (638 cu in)
Compression Ratio	10.5:1
Aspiration	Naturally Aspirated
Rotation (from flywheel end)	Counterclockwise
Flywheel & Flywheel Housing	SAE No. 1
Flywheel teeth	156
Shipping Weight (dry)	1022.3 kg (2253.8 lb)
Power Density	15.5 lb/hp
Power per Displacement	13.8 bhp/L
Capacity for Liquids — L (U.S. gal)	
Cooling System ¹	20 L (5.25 U.S. gal)
Lube Oil System (refill)	44.5 L (11.9 U.S. gal)
Oil Change Interval ²	750 hours
Governor	Electronic ADEM™ A4
Ignition, Protection	Electronic ADEM A4
Air/Fuel Ratio Control	Electronic ADEM A4

¹Engine only.

²Can be extended through S•O•S™ program

FEATURES

Engine Design

- Tough and durable, built on industry standard G3300 platform
- Caterpillar supplied air/fuel ratio control and three-way catalyst designed specifically for this engine to provide superior emissions control with NSPS and Non-Attainment zone compliance
- 0.5 g and 1 g NOx settings available
- Integrated operator interface panel, TWC and AFRC reduces hands-on time with the engine
- Operator interface panel allows setup and servicing without a laptop
- Runs on a broad range of fuels and speeds at any emissions level
- Factory installed components with single connection point eases packaging

Advanced Digital Engine Management

The ADEM A4 system represents the next generation of engine management systems while reducing the number of mechanical components and easing troubleshooting.

Features include:

- Air/Fuel Ratio Control (AFRC)
- Electronic ignition
- Electronic governing/speed control
- Start/stop logic
- Engine protection & monitoring

Full Range of Attachments

Large variety of factory-installed engine attachments reduces packaging time

Gas Engine Rating Pro (GERP)

GERP is a PC-based program designed to provide site performance capabilities for Cat® natural gas engines for the gas compression industry. GERP provides engine data for your site's altitude, ambient temperature, fuel, engine coolant heat rejection, performance data, installation drawings, spec sheets, and pump curves.

Product Support Offered Through Global Cat Dealer Network

More than 2,200 dealer outlets

Cat factory-trained dealer technicians service every aspect of your petroleum engine

Caterpillar parts and labor warranty

Preventive maintenance agreements available for repair-before-failure options

S•O•S™ program matches your oil and coolant samples against Caterpillar set standards to determine:

- Internal engine component condition
- Presence of unwanted fluids
- Presence of combustion by-products
- Site-specific oil change interval

Over 80 Years of Engine Manufacturing Experience

Over 60 years of natural gas engine production

Ownership of these manufacturing processes enables Caterpillar to produce high quality, dependable products.

- Cast engine blocks, heads, cylinder liners, and flywheel housings
- Machine critical components
- Assemble complete engine

Web Site

For all your petroleum power requirements, visit HYPERLINK "<http://www.catoilandgas.cat.com>" www.catoilandgas.cat.com

**STANDARD EQUIPMENT**

Air Inlet System

Air cleaner — intermediate duty, dry
Air cleaner rain cap (shipped loose)
Service indicator

Control System

ADEM A4

Cooling System

Thermostats and housing — full open
temperature 97°C (207°F)
Jacket water pump — gear-driven, centrifugal,
non-self-priming

Exhaust System

Exhaust manifolds — watercooled
Exhaust elbow — dry
102 mm (4 in)
Three-way catalyst — 1.0 g NO_x and 0.5 g NO_x
catalyst options

Flywheels & Flywheel Housings

Flywheel, SAE No. 1
Flywheel housing, SAE No. 1
SAE standard rotation

Fuel System

Air/fuel ratio control
Gas pressure regulator
Requires 10.3-34.5 kPa (1.5-5 psi) gas
Natural gas carburetor

Ignition System

ADEM A4 ignition

Lube System

Crankcase breather, top mounted
Oil cooler
Oil filter
Oil pan, full sump
Oil filler and dipstick

Protection System

The following parameters include alarm and
shutdown

- oil pressure
- oil temperature
- coolant temperature
- engine speed (overspeed)
- battery voltage
- catalyst inlet/outlet temperature (sensors
shipped loose)

Display only — service hours

OPTIONAL EQUIPMENT

Charging Alternator

24V, 35A alternator
24V, 35A CSA alternator*

Cooling System

Radiators
Jacket water pump inlet adapter

Exhaust System

Exhaust flex fitting — ANSI flange
Exhaust elbow
Exhaust flange — ANSI flange

Guards

Fan guard
Damper guard

Ignition System

CSA certified electronics and ignition*

Instrumentation

Operator interface panel
Operator interface panel enclosure
15', 20' and 50' interconnect harness

Starting System

Air pressure regulator
Air start silencer
Vane starter
Electric starter
Turbine starter

*CSA certification pending final approval



G3306B NA GAS PETROLEUM ENGINE

108 bkW (145 bhp)

TECHNICAL DATA

G3306B Gas Petroleum Engine — 1800 rpm

		DM8970-01 0.5 g NOx NTE	DM8798-01 1.0 g NOx NTE
Engine Power @ 100% Load	bkW (bhp)	108 (145)	108 (145)
Engine Speed	rpm	1800	1800
Max Altitude @ Rated Torque and 38°C (100°F)	m (ft)	0	0
Speed Turndown @ Max Altitude, Rated Torque, and 38°C (100°F)	%	48	48
Compression Ratio		10.5:1	10.5:1
Emissions (NTE)*			
NOx	g/bkW-hr (g/bhp-hr)	0.67 (0.5)	1.34 (1.0)
CO	g/bkW-hr (g/bhp-hr)	2.68 (2.0)	2.68 (2.0)
CO ₂	g/bkW-hr (g/bhp-hr)	655.8 (489)	655.8 (489)
VOC**	g/bkW-hr (g/bhp-hr)	0.27 (0.20)	0.27 (0.20)
Fuel Consumption***			
@ 100% Load	MJ/bkW-hr (Btu/bhp-hr)	11 (7775)	11 (7775)
@ 75% Load	MJ/bkW-hr (Btu/bhp-hr)	11.8 (8318)	11.8 (8318)
Heat Balance			
Heat Rejection to Jacket Water			
JW	bkW (Btu/min)	105.63 (6007)	105.63 (6007)
OC	bkW (Btu/min)	15.76 (896)	15.76 (896)
Heat Rejection to Exhaust @ 100% Load	bkW (Btu/min)	87.45 (4973)	87.45 (4973)
Heat Rejection to Atmosphere @ 100% Load	bkW (Btu/min)	13.21 (751)	13.21 (751)
Exhaust System			
Exhaust Gas Flow Rate	m ³ /min (cfm)	19.9 (706)	19.9 (706)
Exhaust Temperature — Catalyst Outlet @ 100% Load	°C (°F)	626.7 (1160)	626.7 (1160)
Intake System			
Air Inlet Flow Rate @ 100% Load	m ³ /min (scfm)	5.92 (209)	5.92 (209)
Gas Pressure	psig (kPag)	1.5-10 (10-69)	1.5-10 (10-69)

*at 100% load and speed, listed as not to exceed

**Volatile organic compounds as defined in U.S. EPA 40 CFR 60, subpart JJJ

***ISO 3046/1



G3306B NA GAS PETROLEUM ENGINE

108 bkW (145 bhp)

GAS PETROLEUM ENGINE

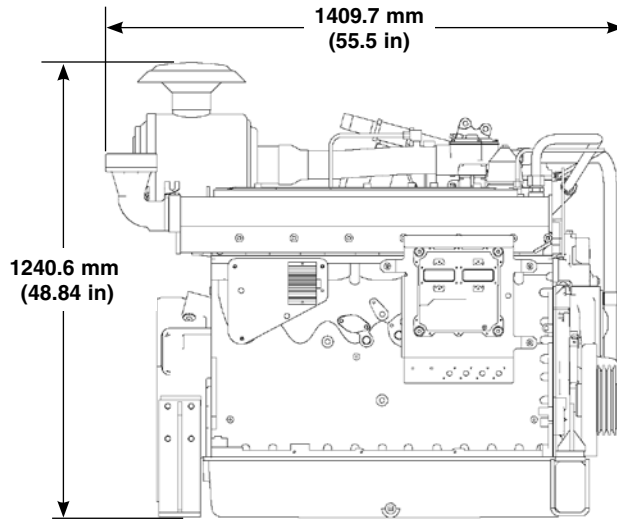

RIGHT SIDE VIEW

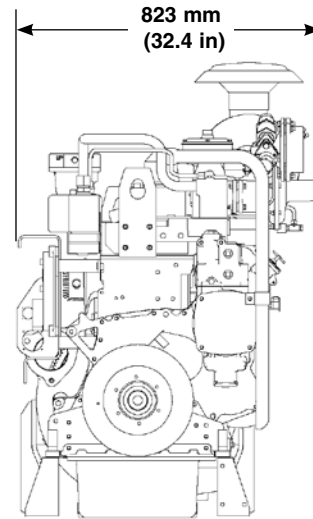

FRONT VIEW

DIMENSIONS		
Length	mm (in)	1409.7 (55.5)
Width	mm (in)	823 (32.4)
Height	mm (in)	1240.6 (48.84)
Shipping Weight	kg (lb)	1022.3 (2253.8)

RATING DEFINITIONS AND CONDITIONS

Engine performance is obtained in accordance with SAE J1995, ISO3046/1, BS5514/1, and DIN6271/1 standards.

Transient response data is acquired from an engine/generator combination at normal operating temperature and in accordance with ISO3046/1 standard ambient conditions. Also in accordance with SAE J1995, BS5514/1, and DIN6271/1 standard reference conditions.

Conditions: Power for gas engines is based on fuel having an LHV of 33.74 kJ/L (905 Btu/cu ft) at 101 kPa (29.91 in Hg) and 15°C (59°F). Fuel rate is based on a cubic meter at 100 kPa (29.61 in Hg) and 15.6°C (60.1°F). Air flow is based on a cubic foot at 100 kPa (29.61 in Hg) and 25°C (77°F). Exhaust flow is based on a cubic foot at 100 kPa (29.61 in Hg) and stack temperature.

Materials and specifications are subject to change without notice. The International System of Units (SI) is used in this publication. CAT, CATERPILLAR, their respective logos, ADEM, S•O•S, "Caterpillar Yellow" and the "Power Edge" trade dress, as well as corporate and product identity used herein, are trademarks of Caterpillar and may not be used without permission.