

Image may not reflect actual engine

### STANDARD EQUIPMENT

#### Air Inlet System

Corrosion-resistant, separate circuit aftercooler core (air side); regular duty air cleaner; dual turbochargers, 152 mm (6 in.) OD

#### Cooling System

Non-self-priming centrifugal auxiliary sea water pump, gear driven centrifugal jacket water pump, auxiliary fresh water pump, expansion tank, oil cooler, thermostats and housing with 92°C (198°F)

#### Exhaust System

Dry, gas tight manifolds with thermo-laminated heat shields; dual turbochargers with watercooled bearings and thermo-laminated heat shields; vertical exhaust outlet, 305 mm (12 in.) round flanged outlet

#### Flywheel and Flywheel Housing

SAE No. 00 (183 teeth)

#### Fuel System

RH fuel filter with service indicators, fuel transfer pump, Electronic Unit Injector (EUI) fuel system

#### Instruments

RH instrument panel with oil pressure, water temperature, and fuel pressure gauges; system DC voltage gauge; air inlet restriction gauge; exhaust temperature gauges; fuel and oil filter differential pressure gauges; service meter; tachometer; instantaneous fuel consumption; 4-position start-stop

#### Lube System

Top-mounted crankcase breather, RH oil filter and oil level gauge, gear-type oil pump, deep sump oil pan

#### Mounting System

Engine length mounting rails, 254 mm (10 in.), C-channel

#### Power Take-Offs

Lower RH and LH accessory drive, two-sided front housing

#### General

Vibration damper and guard, Caterpillar yellow paint, lifting eyes

### SPECIFICATIONS

#### V-12, 4-Stroke-Cycle-Diesel

Displacement . . . . . 51.8 L (3158 cu. in.)  
Bore . . . . . 170 mm (6.7 in.)  
Stroke . . . . . 190 mm (7.5 in.)  
Aspiration . . . . . Turbocharged-Aftercooled  
Governor . . . . . Electronic  
Engine Weight, Net Dry (approx) . . 6532 kg (14400 lb)  
Capacity for Liquids  
Cooling System (engine only) . . 289.3 L (76.4 U.S. gal)  
Lube Oil System . . . . . 613 L (162 U.S. gal)  
Oil Change Interval . . . . . 1000 hr  
Caterpillar® DEO 10W30 or 15W40  
Rotation (from flywheel end) . . . . . ccw or cw

### ACCESSORY EQUIPMENT

24V 60 amp alternator  
24V electric prelube pump  
24V electric starting motor  
Air inlet overspeed shutoffs  
Air starting motor  
Auxiliary drive pulley and shaft  
Crankshaft pulleys  
Customer Communications Module — CCM  
Dual jacket water heater  
Duplex fuel filter  
Duplex oil filter  
Exhaust elbow, flange, flexible fitting  
Front enclosed clutch  
Front stub shafts  
Fuel priming pump  
Generator — 880 to 1360 kW, air filter, bearing temperature detectors, low voltage extension box, RFI filter, voltage regulator (auto, digital, manual)  
Heat exchanger  
Instrument panel extension harness — 8M or 16M  
Keel cooling connections  
Load sharing module  
Premium instrument panel  
Premium wiring harness  
Program relay control module  
Pyrometer and thermocouples  
Pyrometer extension harness — 8M or 16M  
Radiator cooling conversion  
Self priming auxiliary sea water pump  
Shutoff and alarm contactors for oil pres. and water temp.  
Spare parts kit  
Standard sump oil pan  
Sump pump  
Upper RH accessory drives  
Vibration isolators

### PERFORMANCE DATA

Turbocharged-Aftercooled

**DM4596-00** Aftercooler Temperature 30°C (86°F)

1020 bkW (.8 pf) 1368 bhp			
% load	bkW	Lph	gph
100	1017	241.7	63.9
75	760	187.5	49.5
50	508	132.4	35.0
25	259	77.3	20.4

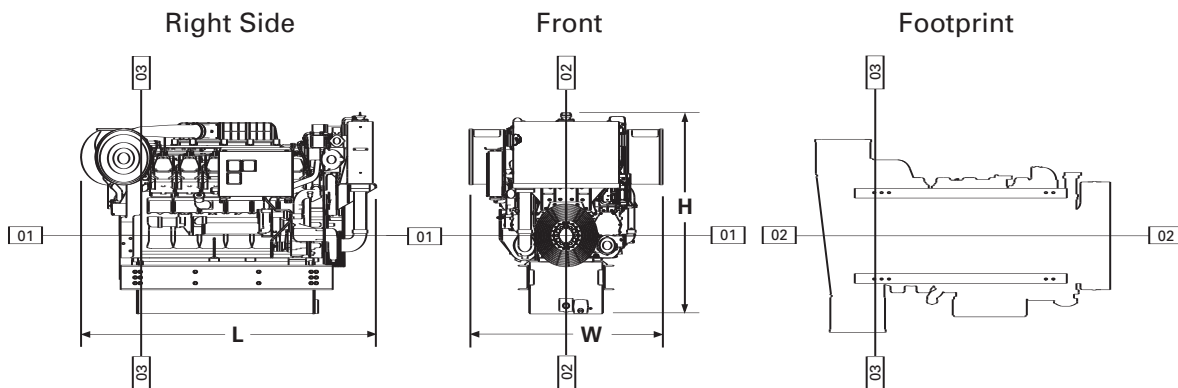

### DIMENSIONS\*

	mm	in.		mm	in.	
<b>Overall Length</b>	3038.6	119.6				
Length from front to rear face of block	2420.0	95.3				
Length from rear face of block to back of engine	618.6	24.4				
<b>Overall Height</b>	2073.8	81.7				
Height from crankshaft centerline to top of engine	1267.1	49.9				
Height from crankshaft centerline to bottom of rails	806.7	31.8				
<b>Overall Width</b>	1988.0	78.3				
Width from crankshaft centerline to port side (left side)	994.0	39.1				
Width from crankshaft centerline to starboard side (right side)	994.0	39.1				
			<b>Front</b>	<b>Rear</b>		
			<b>mm</b>	<b>in.</b>	<b>mm</b>	<b>in.</b>
Customer mounting hole diameter	23.8	0.9	23.8	0.9		
Width from crankshaft centerline to side	444.5	17.5	444.5	17.5		
Length from rear face of block to mounting hole	1758.0	69.2	65.7	2.6		
	1834.2	72.2	141.9	5.6		
			10.5	0.4		

\*Illustrations and dimensions from drawing: 125-6279.

### RATING CONDITIONS

#### Engine Performance Parameters

Power.....	±3%
Specific Fuel Consumption .....	±3%
Fuel Rate.....	±5%

**Ratings** are based on SAE J1228/ISO8665 standard conditions of 100 kPa (29.61 in. Hg), 25°C (77°F), and 30% relative humidity. These ratings also apply at ISO3046/1, DIN6271/3, and BS5514 conditions of 100 kPa (29.61 in. Hg), 27°C (81°F), and 60% relative humidity.

**Fuel rates** are based on fuel oil of 35° API [16°C (60°F)] gravity having an LHV of 42 780 kJ/kg (18,390 Btu/lb) when used at 29°C (85°F) and weighing 838.9 g/L (7.001 lb/U.S. gal).

Additional ratings may be available for specific customer requirements. Consult your Caterpillar representative for additional information.

Performance data is calculated in accordance with tolerances and conditions stated in this specification sheet and is only intended for purposes of comparison with other manufacturers' engines. Actual engine performance may vary according to the particular application of the engine and operating conditions beyond Caterpillar's control.

CAT, CATERPILLAR, their respective logos, "Caterpillar Yellow" and the POWER EDGE trade dress, as well as corporate and product identity used herein, are trademarks of Caterpillar and may not be used without permission.