

Image may not reflect actual engine

STANDARD EQUIPMENT

Air Inlet System

Corrosion-resistant, separate circuit aftercooler core (air side); regular duty air cleaner; dual turbochargers, 152 mm (6 in.) OD

Cooling System

Non-self-priming centrifugal auxiliary sea water pump, gear driven centrifugal jacket water pump, auxiliary fresh water pump, expansion tank, oil cooler, thermostats and housing with 92°C (198°F)

Exhaust System

Dry, gas tight manifolds with thermo-laminated heat shields; dual turbochargers with watercooled bearings and thermo-laminated heat shields; vertical exhaust outlet, 305 mm (12 in.) round flanged outlet

Flywheel and Flywheel Housing

SAE No. 00 (183 teeth)

Fuel System

RH fuel filter with service indicators, fuel transfer pump, Electronic Unit Injector (EUI) fuel system

Instruments

RH instrument panel with oil pressure, water temperature, and fuel pressure gauges; system DC voltage gauge; air inlet restriction gauge; exhaust temperature gauges; fuel and oil filter differential pressure gauges; service meter; tachometer; instantaneous fuel consumption; 4-position start-stop

Lube System

Top-mounted crankcase breather, RH oil filter and oil level gauge, gear-type oil pump, deep sump oil pan

Mounting System

Engine length mounting rails, 254 mm (10 in.), C-channel

Power Take-Offs

Lower RH and LH accessory drive, two-sided front housing

General

Vibration damper and guard, Caterpillar yellow paint, lifting eyes

SPECIFICATIONS

V-12, 4-Stroke-Cycle-Diesel

Displacement 51.8 L (3158 cu. in.)
Bore 170 mm (6.7 in.)
Stroke 190 mm (7.5 in.)
Aspiration Turbocharged-Aftercooled
Governor Electronic
Engine Weight, Net Dry (approx) . . 6532 kg (14400 lb)
Capacity for Liquids
Cooling System (engine only) . . 289.3 L (76.4 U.S. gal)
Lube Oil System 613 L (162 U.S. gal)
Oil Change Interval 1000 hr
Caterpillar DEO 10W30 or 15W40
Rotation (from flywheel end) ccw or cw

ACCESSORY EQUIPMENT

24V 60 amp alternator
24V electric prelube pump
24V electric starting motor
Air inlet overspeed shutoffs
Air starting motor
Auxiliary drive pulley and shaft
Crankshaft pulleys
Customer Communications Module — CCM
Dual jacket water heater
Duplex fuel filter
Duplex oil filter
Exhaust elbow, flange, flexible fitting
Front enclosed clutch
Front stub shafts
Fuel priming pump
Generator — 880 to 1360 ekW, air filter, bearing temperature detectors, low voltage extension box, RFI filter, voltage regulator (auto, digital, manual)
Heat exchanger
Instrument panel extension harness — 8M or 16M
Keel cooling connections
Load sharing module
Premium instrument panel
Premium wiring harness
Program relay control module
Pyrometer and thermocouples
Pyrometer extension harness — 8M or 16M
Radiator cooling conversion
Self priming auxiliary sea water pump
Shutoff and alarm contactors for oil pres. and water temp.
Spare parts kit
Standard sump oil pan
Sump pump
Upper RH accessory drives
Vibration isolators

PERFORMANCE DATA

Turbocharged-Aftercooled

DM4598-01 Aftercooler Temperature 30°C (86°F)

1125 bkW (.8 pf) 1509 bhp			
% load	bkW	Lph	gph
100	1119	276.8	73.1
75	837	214.9	56.8
50	561	153.7	40.6
25	288	93.0	24.6

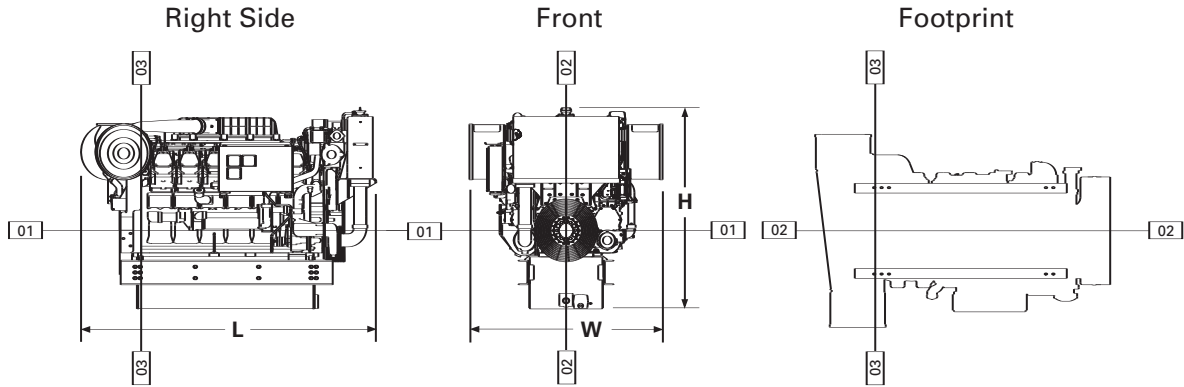

DIMENSIONS*

	mm	in.		
Overall Length	3038.6	119.6		
Length from front to rear face of block	2420.0	95.3		
Length from rear face of block to back of engine	618.6	24.4		
Overall Height	2073.8	81.7		
Height from crankshaft centerline to top of engine	1267.1	49.9		
Height from crankshaft centerline to bottom of rails	806.7	31.8		
Overall Width	1988.0	78.3		
Width from crankshaft centerline to port side (left side)	994.0	39.1		
Width from crankshaft centerline to starboard side (right side)	994.0	39.1		
			Front	Rear
			mm	in.
Customer mounting hole diameter	23.8	0.9	23.8	0.9
Width from crankshaft centerline to side	444.5	17.5	444.5	17.5
Length from rear face of block to mounting hole	1758.0	69.2	65.7	2.6
	1834.2	72.2	141.9	5.6
			10.5	0.4

*Illustrations and dimensions from drawing: 125-6279.

RATING CONDITIONS

Engine Performance Parameters

Power.....	±3%
Specific Fuel Consumption	±3%
Fuel Rate	±5%

Ratings are based on SAE J1228/ISO8665 standard conditions of 100 kPa (29.61 in. Hg), 25°C (77°F), and 30% relative humidity. These ratings also apply at ISO3046/1, DIN6271/3, and BS5514 conditions of 100 kPa (29.61 in. Hg), 27°C (81°F), and 60% relative humidity.

Fuel rates are based on fuel oil of 35° API [16°C (60°F)] gravity having an LHV of 42 780 kJ/kg (18,390 Btu/lb) when used at 29°C (85°F) and weighing 838.9 g/L (7.001 lb/U.S. gal).

Additional ratings may be available for specific customer requirements. Consult your Caterpillar representative for additional information.

Performance data is calculated in accordance with tolerances and conditions stated in this specification sheet and is only intended for purposes of comparison with other manufacturers' engines. Actual engine performance may vary according to the particular application of the engine and operating conditions beyond Caterpillar's control.

CAT, CATERPILLAR, their respective logos, "Caterpillar Yellow" and the POWER EDGE trade dress, as well as corporate and product identity used herein, are trademarks of Caterpillar and may not be used without permission.