



C18 ACERT™ Industrial Engine

Tier 4 Final, EU Stage IV Technology
429-469 bkW/575-630 bhp @ 1800-2000 rpm

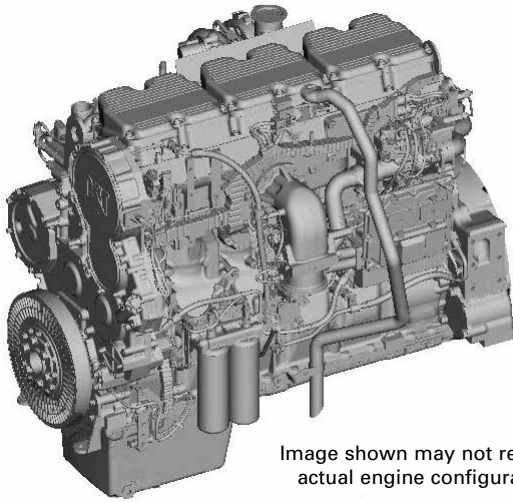

Image shown may not reflect actual engine configuration

CAT® ENGINE SPECIFICATIONS

I-6, 4-Stroke-Cycle Diesel

Bore	145 mm (5.71 in)
Stroke	183 mm (7.20 in)
Displacement	18.1 L (1104.5 in ³)
Aspiration	Turbocharged-Aftercooled
Compression Ratio	16.0:1
Combustion System	Direct Injection
Rotation (from flywheel end) ...	Counterclockwise
Capacity for Liquids	
Cooling System	26.9 L (28.4 U.S. qts)
Lube System (refill) ...	40-74 L (42.3-78.1 U.S. qts)
Engine Weight, Net Dry (basic operating engine without optional attachments) (approximate)	1542 kg (3399.5 lbs)

FEATURES

Emissions

Designed to meet U.S. EPA Tier 4 Final, EU Stage IV emission standards.

Reliable, Quiet, and Durable Power

World-class manufacturing capability and processes coupled with proven core engine designs assure reliability, quiet operation, and many hours of productive life.

High Performance

Simple and efficient turbocharger with balance valve provides optimal air management and improved fuel efficiency.

Fuel Efficiency

Fuel consumption optimized to match operating cycles of a wide range of equipment and applications.

Fuel & Oil

Tier 4 Final, Stage IV engines require Ultra Low Sulfur Diesel (ULSD) fuel containing a maximum of 15 ppm sulfur, and new oil formulations to support the new technology. Cat® engines are designed to accommodate B20 biofuel. Your Cat dealer can provide more information regarding fuel and oil.

Broad Application Range

Industry-leading range of factory configurable ratings and options for agricultural, materials-handling, construction, mining, forestry, waste, and other industrial applications.

Package Size

Exceptional power density enables standardization across numerous applications. Multiple installation options available to minimize total package size.

Low-Cost Maintenance

Worldwide service delivers ease of maintenance and simplifies the servicing routine. Minimum 5000-hour diesel particulate filter (DPF) ash service interval enables low-cost maintenance. Capable of optimal oil change intervals of up to 500 hours, depending on rating, application, operating conditions, and maintenance practices. Engine is designed for a B10 life of up to 10,000 hours. The S•O•SSM program is available from your Cat dealer to determine oil change intervals and provide optimal performance.

Quality

Every Cat engine is manufactured to stringent standards in order to assure customer satisfaction.

World-class Product Support Offered Through Global Cat Dealer Network

- Scheduled maintenance, including S•O•SSM sample
- Customer Support Agreements (CSA)
- Caterpillar Extended Service Coverage (ESC)
- Superior dealer service network
- Extended dealer service network through the Cat Industrial Service Distributor (ISD) program

Web Site: For additional information on all your power requirements, visit www.cat-industrial.com.



C18 ACERT™ Industrial Engine

Tier 4 Final, EU Stage IV Technology
429-469 kW/575-630 bhp @ 1800-2000 rpm

STANDARD ENGINE EQUIPMENT

Control System

Electronic control system, over-foam wiring harness, automatic altitude compensation, power compensated for fuel temperature, remote fan control, configurable software features, engine monitoring system SAE J1939 broadcast and control, integrated Electronic Control Unit (ECU)

Cooling System

Vertical outlet thermostat housing, centrifugal water pump, guidance on cooling system design available through your dealer to ensure equipment reliability

Exhaust System

Mid-mount turbocharged system with front and rear exhaust configurations

Flywheels and Flywheel Housing

SAE No. 0 and SAE No. 1 flywheel housings; available SAE 1 power take-off housing with optional SAE A, SAE B, and SAE C power take-off drives; engine power can also be taken from the front of the engine with optional attachments

Fuel System

MEUI injection; primary fuel filter, secondary fuel filters, fuel transfer pump, electronic fuel priming

Lube System

Open crankcase ventilation system with fumes disposal (optional OCV filter system); oil cooler, oil filler, oil filter, oil dipstick, oil pump (gear-driven); choice of sumps (front, rear, and center)

General

Paint: Cat yellow, with optional colors available at request

DIMENSIONS

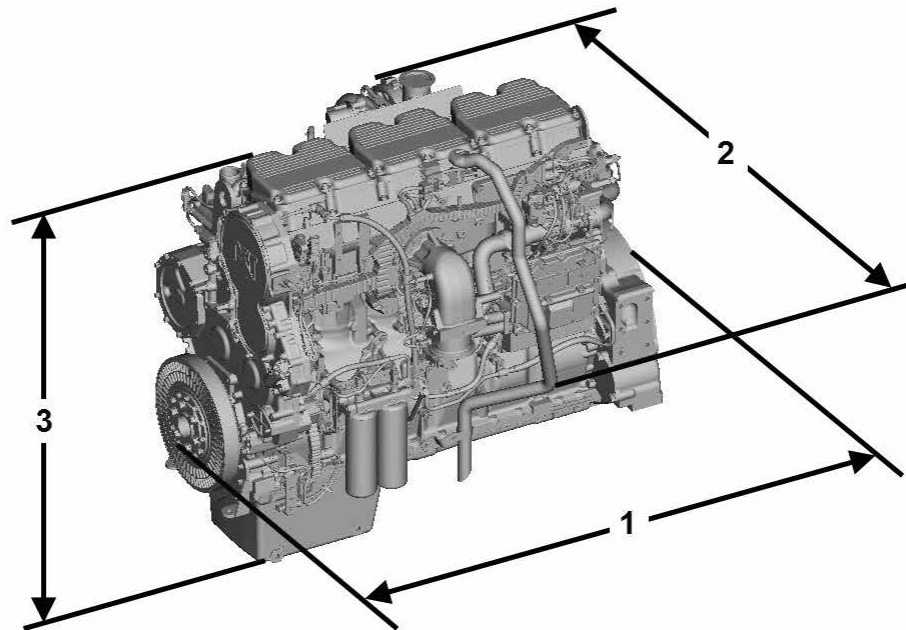

(1) Length — 1438 mm (56.6 in) (2) Width — 969 mm (38.1 in) (3) Height — 1248 mm (49.1 in)

Note: Final dimensions dependent on selected options



PERFORMANCE DATA — PRELIMINARY

Turbocharged-Aftercooled — 1800-2000 rpm

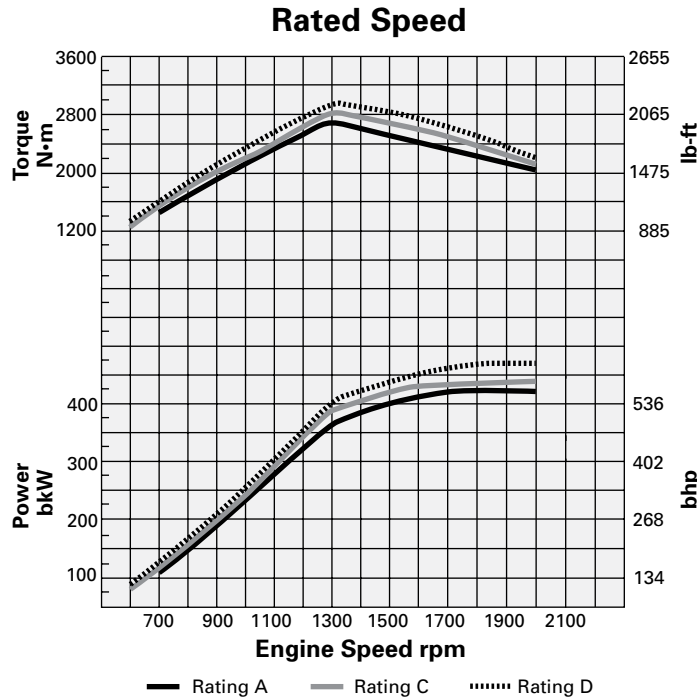

Speed Range

Rating	Aspiration	Rated Speed rpm	Rated Power kW	Rated Power bhp	Speed rpm	Peak Torque N·m	Peak Torque lb-ft
A	TA	2000	429	575	1300	2694	1987
B	TA	2000	447	600	1300	2811	2073
C	TA	2000	470	630	1300	2951	2176

RATING DEFINITIONS AND CONDITIONS

IND-A (Continuous) for heavy duty service where the engine is operated at maximum power and speed up to 100% of the time without interruption or load cycling.

IND-B for service where power and/or speed are cyclic (time at full load not to exceed 80%).

IND-C (Intermittent) is the horsepower and speed capability of the engine where maximum power and/or speed are cyclic (time at full load not to exceed 50%).

Rating Conditions are based on SAE J1995, inlet air standard conditions of 99 kPa (29.31 in Hg) dry barometer and 25°C (77°F) temperature. Performance measured using a standard fuel with fuel gravity of 35° API having a lower heating value of 42 780 kJ/kg (18,390 btu/lb) when used at 29°C (84.2°F) with a density of 838.9 g/L.



C18 ACERT™ Industrial Engine

Tier 4 Final, EU Stage IV Technology
429-469 bkW/575-630 bhp @ 1800-2000 rpm

AFTERTREATMENT CONFIGURATION

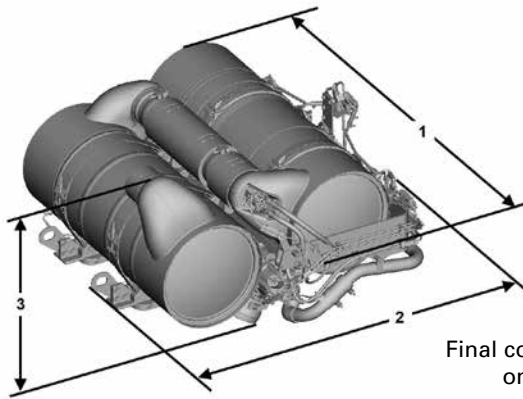

Final configuration dependent on selected options

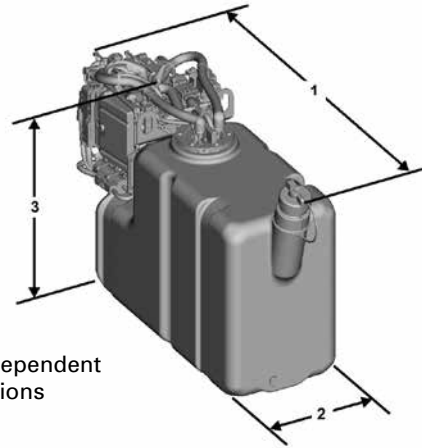

STANDARD CONFIGURATION SHOWN

Approximate Size and Weight

- (1) Length — 1153 mm (45.4 in)
- (2) Width — 1112 mm (43.8 in)
- (3) Height — 652 mm (25.7 in)
- Weight — 268 kg (590.8 lbs)

MAXIMUM 48.4 L (51.1 U.S. qt) PETU CONFIGURATION SHOWN

- (1) Length — 854 mm (33.6 in)
- (2) Width — 287 mm (11.3 in)
- (3) Height — 551 mm (21.7 in)
- Weight, dry — 19.42 kg (42.8 lbs)

CEM Configuration

Standard configuration includes Diesel Particulate Filter (DPF), Diesel Oxidation Catalyst (DOC), Selective Catalytic Reduction (SCR), and supporting structure. Multiple configuration options available for Cat Regeneration System.

PETU Configuration

Pump Electronic Tank Unit (PETU), consisting of Diesel Exhaust Fluid (DEF) tank with integrated Dosing Control Unit (DCU). Available in different volume configurations.

Contact your Cat dealer for additional information.

AFTERTREATMENT FEATURES

Regeneration: Cat Regeneration System maximizes fuel efficiency during regeneration. Transparent regeneration maximizes uptime.

Mounting: Remote installation options provide OEM flexibility for many applications, including horizontal and vertical mounting.

Service: Minimum 5000-hour diesel particulate filter ash service interval. PETU filter service is 5000 hours.

Available in 12V or 24V systems

STANDARD EMISSIONS CONTROL EQUIPMENT

Cat Regeneration System

CEM: Clean Emissions Module

DOC: Diesel Oxidation Catalyst

ECU: Aftertreatment Electronic Control Unit

DPF: Diesel Particulate Filter

NRS: NOx Reduction System

SCR: Selective Catalytic Reduction

PETU: Pump Electronic Tank Unit

Materials and specifications are subject to change without notice. The International System of Units (SI) is used in this publication. CAT, CATERPILLAR, their respective logos, ACERT, S•O•S, "Caterpillar Yellow" and the "Power Edge" trade dress, as well as corporate and product identity used herein, are trademarks of Caterpillar and may not be used without permission.