

THE CAT® TR43-M44 TRANSMISSION

The Cat® TR43-M44 transmission is designed for 2WD or 4WD locomotive, subway, and railway applications. It's compatible with the Cat C13B and C18 engines and can be used by vehicles that frequently make directional changes during a normal work cycle.

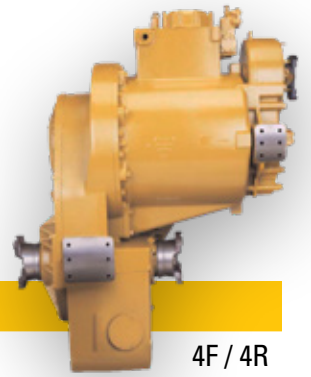

NUMBER OF GEARS

# Gears (Forward/Reverse)	4F / 4R
---------------------------	---------

RATINGS

Maximum Input Power	470 kW	630 hp
Maximum Input Torque	2769 N•m	2,043 lb-ft
Maximum Input Speed		2,100 rpm
Minimum Input Speed		700 rpm

ROTATION

Rotation Direction	SAE J824 Standard, Counterclockwise
Output Rotation	Forward: Clockwise / Reverse: Counterclockwise

MOUNTINGS

Mid-Mount Installation Configuration

ELECTRICAL SYSTEM

Electrical System	12V or 24V
-------------------	------------

TORQUE CONVERTER OPTIONS

Series	TC45, TC46, TC53 w/Lock-Up Clutch
--------	-----------------------------------

CLUTCHES

Electro-Hydraulic Oil Cooled, Multidisc

Cat® Electronic Long Range Transmission (ELRT)

INSTALLATION CONNECTIONS

Input	Yoke (9C)
Output	Yoke (10C) x 2
Electrical Control	1 Bundle
Hydraulic Connections	Oil Cooler, Filter and TC

OIL SYSTEM

Oil	Transmission/Drive Train Oil-4 (TDTO™)
Max Oil Temperatures	Continuous: 95°C (203°F) Max. Intermittent: 116°C (241°F) Max. Converter Outlet Temperature: 124°C (255°F)
Hydraulic Fill Capacity	95 L 20.9 gal
Filter Type	8-Micron Paper Cartridge, Remote Mounted



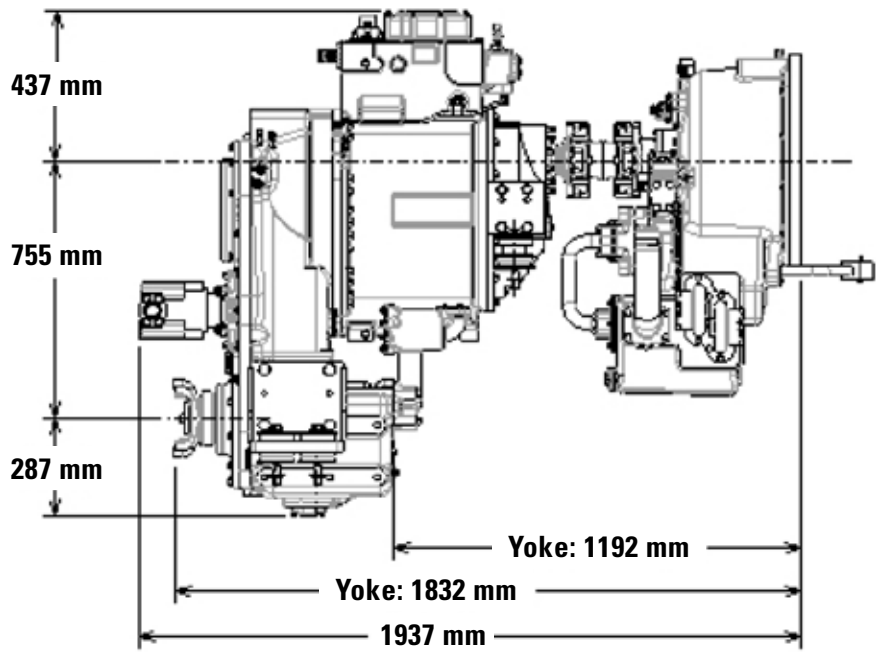
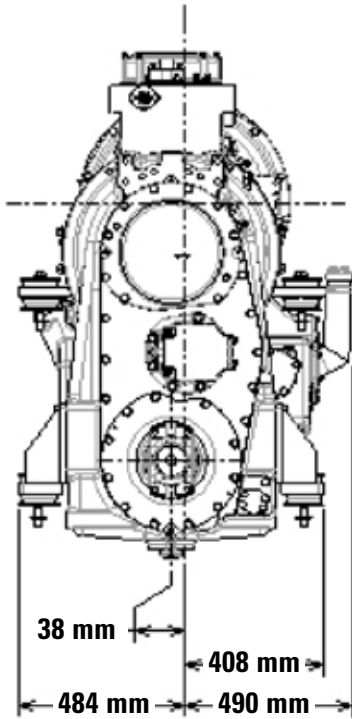

GEARS

	Gear	Ratio
Forward	1F	5.945
	2F	3.323
	3F	1.867
	4F	1.057
Reverse	1R	-5.675
	2R	-3.172
	3R	-1.782
	4R	-1.009

AUXILIARY PUMP DRIVES ON TORQUE CONVERTER (OPTIONAL)

Up to 2 PTOs Integral Live Drive From Input Shaft

Location	1:00 and 11:00
Mountings	Up to 1 Front-Facing Mounting Pad / Up to 2 Rear-Facing Mounting Pads
Rated Torque	37 kW / 50 hp (Each)

WEIGHT

Approximate Dry Weight (Transmission)	1503 kg	3,314 lb
Approximate Dry Weight (Torque Converter)	386 kg	851 lb

For more information, contact your OEM Solutions Account Manager or email oem_solutions@cat.com

AEXJ0170

© 2025 Caterpillar. All rights reserved.

Materials and specifications are subject to change without notice. The International System of Units (SI) is used in this publication.

CAT, CATERPILLAR, LET'S DO THE WORK, their respective logos, "Caterpillar Corporate Yellow," the "Power Edge" and Cat "Modern Hex" trade dress as well as corporate and product identity used herein, are trademarks of Caterpillar and may not be used without permission.

