

THE CAT® TR35 TRANSMISSION

The Cat® TR35 transmission is designed for 2WD or 4WD locomotive, subway, and railway applications. It's compatible with the Cat C9.3 engine and can be used by vehicles that frequently make directional changes during a normal work cycle.

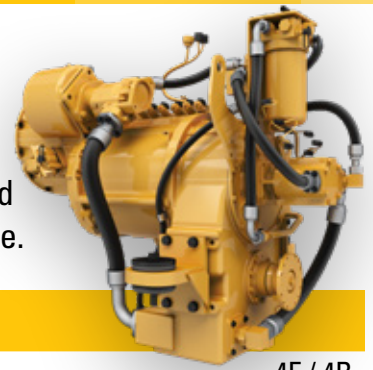

NUMBER OF GEARS

# Gears (Forward/Reverse)	4F / 4R
---------------------------	---------

RATINGS

Rated Input Power	193 - 209 kW	259 - 280 hp
Rated Input Torque	877 - 948 N•m	647 - 699 lb-ft
Rated Input Speed		2,100 rpm
Maximum Input Speed		2,275 rpm
Minimum Input Speed		1,000 rpm

ROTATION

Rotation Direction	SAE J824 Standard, Counterclockwise
Output Rotation	Forward: Counterclockwise / Reverse: Clockwise

MOUNTINGS

Input Connection (Flywheel)	SAE #2 Wet Flywheel Housing with Spline Converter Drive
Output Connection (Yoke)	1710 Round Output Yoke

ELECTRICAL SYSTEM

Electrical System	24V
-------------------	-----

TORQUE CONVERTER

TC36-ESF	Stall Torque Ratio at Rated Speed: 2.443
----------	--

CLUTCHES

Electro-Hydraulic Oil Cooled, Multidisc
Cat® Electronic Clutch Pressure Control (ECPC)

INSTALLATION CONNECTIONS

2 Cooler Lines, 1 Electrical

OIL SYSTEM

Oil	Cat Transmission / Drive Train SAE 30 Transmission Drive Train Oil-4 (or Equivalent)	
Sump Oil Temperatures	Continuous: 90°C (195°F) Operating: 99°C (210°F)	
Hydraulic Fill Capacity	34 L	9 gal
Filter Type	6 Micron Synthetic Cartridge Mounted on Transmission Output	



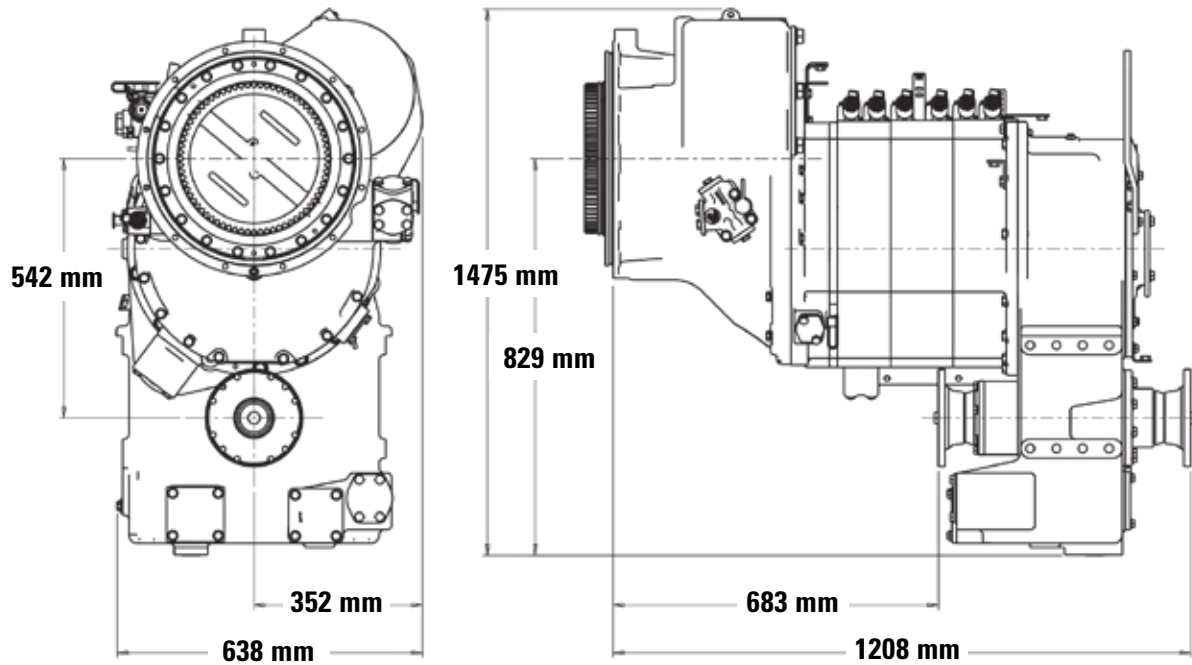

GEARS

Transmission Gearing Type	Helical, Straight Spur Planetary	
	Gear	Ratio
Forward	1F	5.6165
	2F	3.1428
	3F	1.7751
	4F	1.0000
Reverse	1R	-4.9144
	2R	-2.7500
	3R	-1.5532
	4R	-0.8750

WEIGHT

Approximate Dry Weight	1,040 kg	2,300 lb
------------------------	----------	----------

For more information, contact your OEM Solutions Account Manager or email oem_solutions@cat.com

AEXJ0166

© 2025 Caterpillar. All rights reserved.

Materials and specifications are subject to change without notice. The International System of Units (SI) is used in this publication.

CAT, CATERPILLAR, LET'S DO THE WORK, their respective logos, "Caterpillar Corporate Yellow," the "Power Edge" and Cat "Modern Hex" trade dress as well as corporate and product identity used herein, are trademarks of Caterpillar and may not be used without permission.

