

ELIMINATE HOURS OF MAINTENANCE AND DOWNTIME EACH MONTH



WITH THE CAT® HIGH PERFORMANCE CIRCLE FOR MOTOR GRADERS

AVAILABLE ON: 140/150/160 JOYSTICK MODELS

Conventional circles require frequent inspections, wear strip replacements and shoe adjustments — all of which take time away from productive work. Not the Cat® High Performance Circle. It can save you hours of monthly planned maintenance and downtime. And increased service intervals can lower your owning and operating costs. Take a look.

SERVICE MADE SIMPLE 5 WAYS

A fully sealed bearing design replaces the open circle and drawbar. That helps reduce operator touchpoints and increase service intervals.

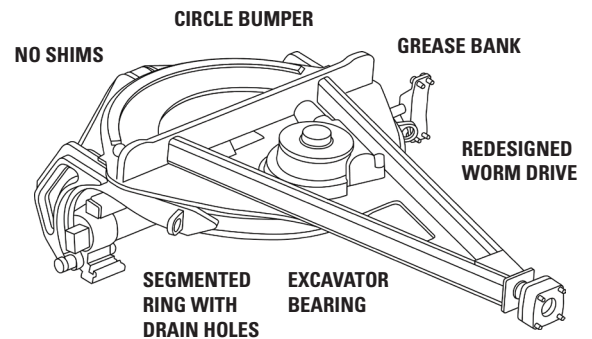

1

NO
CIRCLE SHOE
ADJUSTMENTS

2

NO NEED TO ADJUST
OR REPLACE THE
DRAWBAR AND
CIRCLE WEAR STRIPS

3

LESS
FREQUENT
INSPECTIONS
REQUIRED

4

EXTENDED WEAR
LIFE BETWEEN
CIRCLE AND
DRAWBAR SURFACE

5

ROTATABLE CIRCLE
BEARING FOR LONGER
REPLACEMENT
INTERVALS

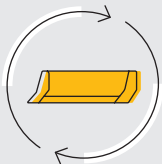

MORE CONFIDENCE IN YOUR TOLERANCE

Less wear between the circle and the drawbar results in smooth, effortless blade rotation. That helps operators meet grade elevation tolerance in road design efficiently — reducing rework.



SAFETY FIRST

Maintenance techs don't need to remove or adjust bulky circle shoes. And they can grease the circle bearing race and circle drive pinion via one centrally located remote grease bank — no bending over or crawling on the ground.

CONTACT YOUR CAT DEALER FOR MORE INFORMATION.

NOTE: The High Performance Circle is not available on 120, 120 GC, 140 GC and 140 LVR models.