

854

WHEEL DOZER



Operating Weight: 101 898 kg (224,647 lb)
Engine Power: 676 kW (907 hp)



CAT® WHEEL DOZERS

**FAST, VERSATILE
& POWERFUL**

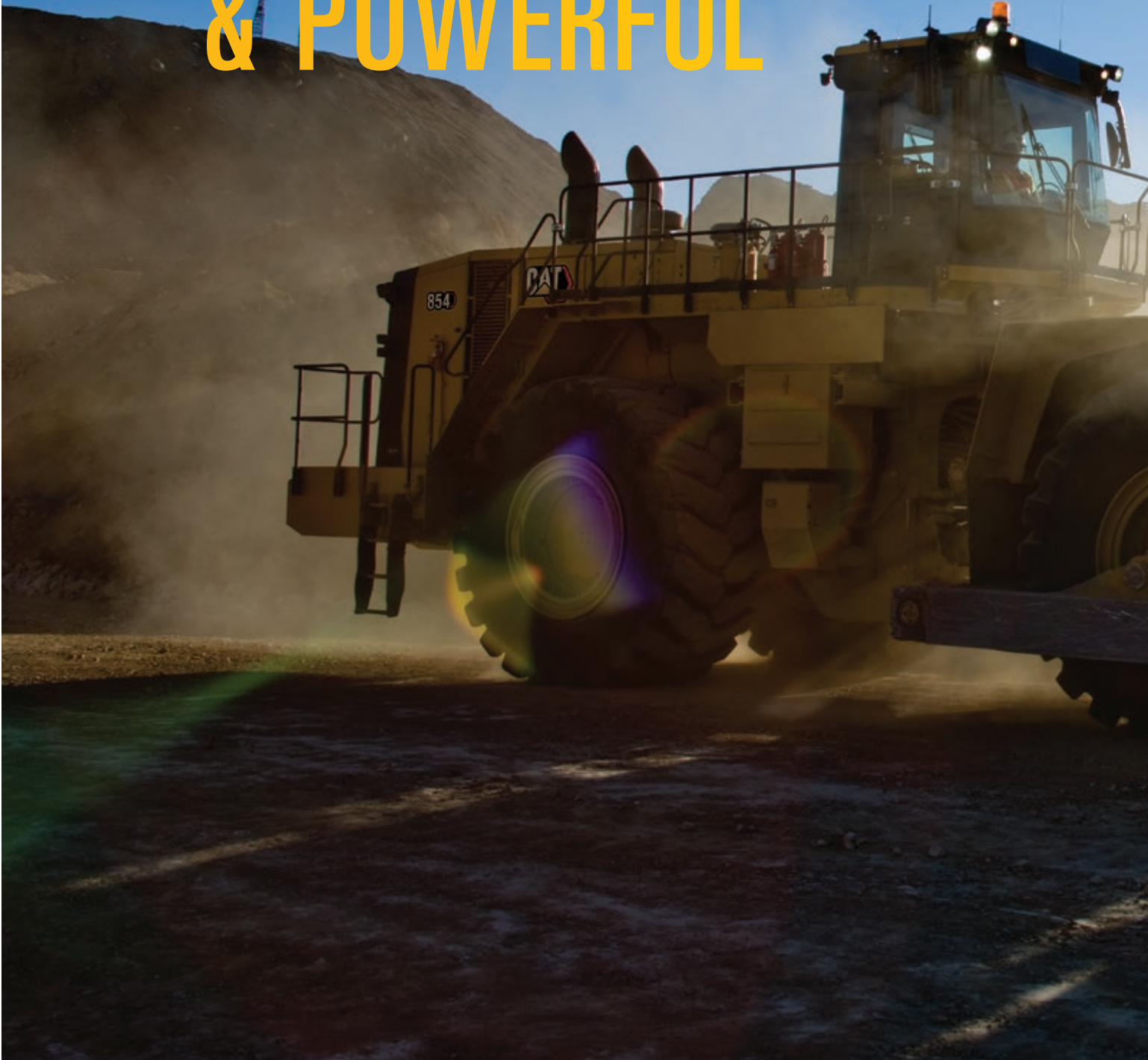

Cat® Wheel Dozers offer high production capabilities, along with mobility and versatility. These utility machines are designed for demanding work and are a great choice for applications including surface mining, cleanup, stockpiles, road maintenance, reclamation and jobs where travel is required between multiple sites.





CAT 854

WHEEL DOZER

THE PERFECT MATCH

Engineered for demanding work in large dozing applications, the Cat 854 Wheel Dozer is the largest in the Cat lineup and is an ideal match for large mining operations, power-generating utilities, the general contracting industry and wherever mobility, versatility and compaction are needed. Like all Cat Wheel Dozers, the 854 is designed with durability built in, ensuring maximum availability through multiple lifecycles. With optimized performance and simplified serviceability, the 854 will allow you to move more material efficiently and safely at a lower cost per ton.

VERSATILE & FLEXIBLE

» Combines speed, mobility and versatility to support multiple activities in large-dozing applications

QUICK CYCLE TIMES

» Thanks to high speed in reverse

COMFORTABLE & PRODUCTIVE CAB

» Unparalleled operator comfort and ergonomics help you get the most from your machine — shift after shift



THE RIGHT DOZER

FOR YOUR APPLICATION

The 854 is a versatile machine that combines speed, mobility and utility to support multiple activities in large-dozing applications, such as stockpile management, road maintenance and reclamation.

The 854 delivers industry-leading productivity. Its powerful engine, best-in-class transmission and efficient hydraulic system allow for fast cycle times and high production — delivering more to your bottom line.



BEST-IN-CLASS TRANSMISSION

The Cat Planetary Powershift Transmission is designed specifically for mining applications. It delivers consistent, smooth shifting and efficiency through integrated electronic controls. It offers three forward and three reverse speeds to match your application.

IMPROVED RIMPULL

Advanced technologies like the Impeller Clutch Torque Converter (ICTC) and Rimpull Control System (RCS) lower costs by improving rimpull control. These technologies reduce tire slippage and wear by modulating rimpull from 100% to 25% while depressing the left pedal. After 25% rimpull is achieved, the left pedal applies the brake. RCS reduces the potential for wheel slippage without reducing hydraulic power. Fuel efficiency is improved in certain applications with the lock-up clutch torque converter providing direct drive.

EFFICIENT POWER

At the heart of the 854 is a Cat C32B engine that delivers on-demand performance through the use of turbochargers and aftercoolers. A 33% torque rise ensures high lugging forces during digging and acceleration in high rimpull conditions. Lower rpm ratings help extend engine life and improve efficiency, and electronic engine controls enable quick engine response.

REDUCED FUEL USAGE

The 854 offers new machine control features that automate functions to conserve fuel.

- + Auto Idle Kickdown with Auto Resume reduces the engine speed to low idle when the machine has been throttle-locked at a higher engine speed and has been in an idle state for an extended period of time. The technology automatically resumes engine speed to previous throttle lock speed when the operator begins working.
- + Engine Idle Shutdown will automatically shut down the engine after extended periods of idling. The loader must be in neutral with the parking brake applied and no movement of any controls for a set period of time (default is 5 minutes).





PRODUCTIVE DOZING BEGINS WITH A **PRODUCTIVE OPERATOR**

DESIGNED FOR **CONFIDENCE**

Confident dozer operation starts with precise machine control enabled by the 854's load-sensing hydraulic steering system. The system helps operators achieve precise positioning for easy loading in tight areas with 43 degrees of steering articulation. Integrated steering and transmission control functions enhance comfort.



DESIGNED FOR COMFORT

Noise, vibration, stress and fatigue all have an effect on operator performance — so we've designed an environment that helps minimize them. The operator station in the 854 reduces effort and exposure. The pressurized cab features a Next Generation Premium Plus Seat with mid-high back and forced air heating and cooling; filtered air and automatic temperature controls; viscous cab mounts and seat air suspension for reduced vibration and reduced sound levels; easy-to-reach seat levers and controls for six-way adjustments; and a seat-mounted implement pod and Steering and Transmission Integrated Control System (STIC™) that moves with the seat. A standard fold-down trainer seat offers drink tray, storage, and a wide, retractable seat belt.

DESIGNED FOR PRODUCTIVITY

We understand that the most important factor in your wheel dozer's effectiveness is the performance of its operator. To help make their workday as productive as possible, we've incorporated a number of productivity features into the 854 operator cab.

The 854's STIC system combines directional selection, gear selection and steering into a single lever for maximum responsiveness and control. A simple side-to-side motion turns the machine right or left, and the finger-controlled gear selection is easy to operate and minimizes operator movements. Low-effort integrated controls make cycles smoother and faster while reducing operator fatigue.

Electro-Hydraulic Controls help operators work more efficiently and productively. The soft detent controls are easy to use, and electronically controlled hydraulic cylinder stops boost comfort. Operators can conveniently set automatic implement kickouts from inside the cab. Joystick or single axis levers are available.

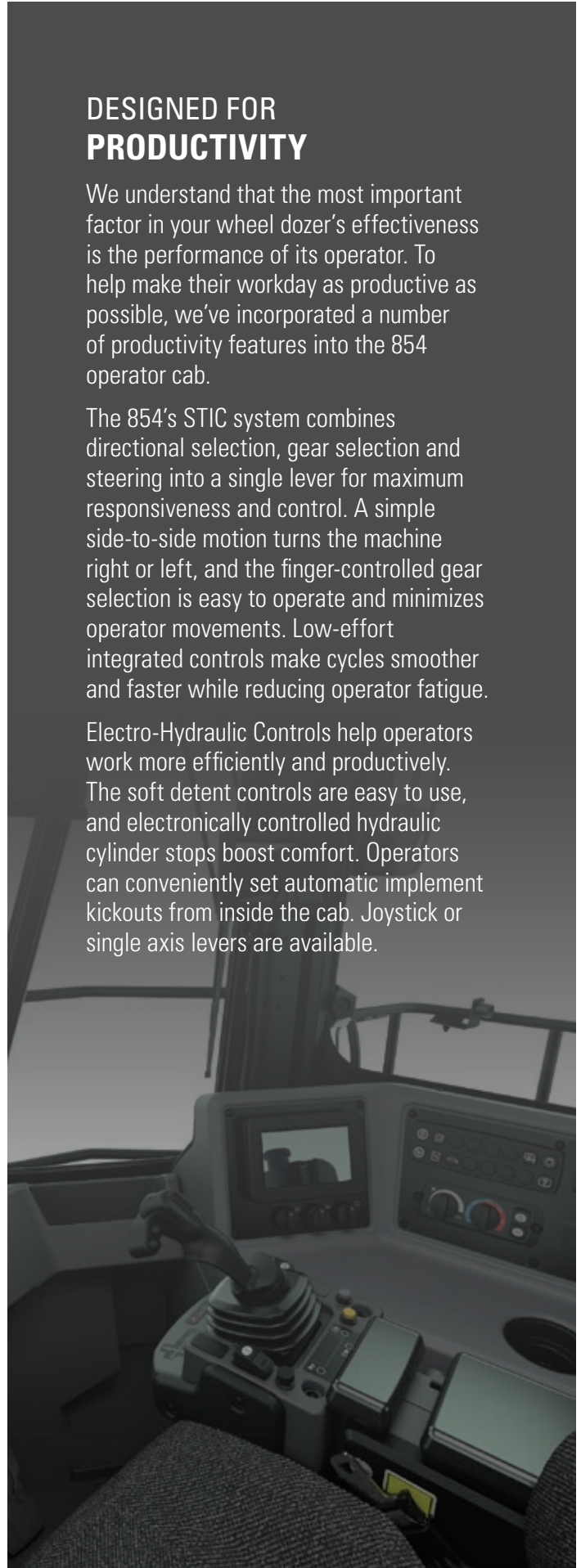

FOCUS ON SAFETY

From slip-resistant surfaces and guard rails to state-of-the-art object detection technologies, the 854 is infused with features to help both operators and service personnel feel safe and confident on the job. We've improved access and egress, maximized visibility and made it possible to perform more service from the ground.

- Cab-mounted LED warning beacons
- Heated mirrors
- Optional pull-down window shade
- Windshield cleaning platform

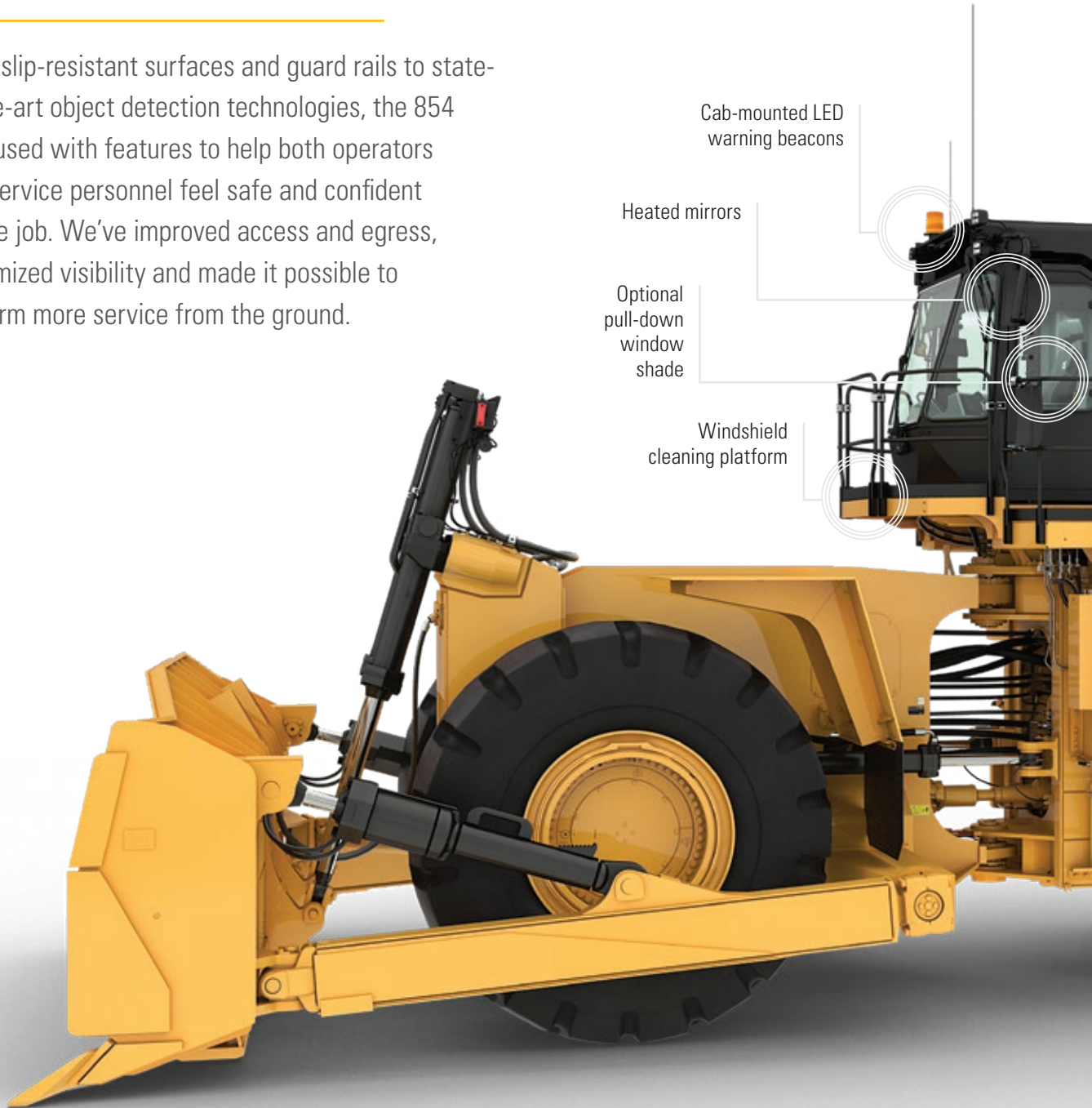

SAFER ACCESS AND EGRESS

A powered access system allows easier access to the primary stairs by improving ingress and egress to and from the rear platform. Wide stairs are at a 45-degree angle for easy access and feature full handrails on each side. Stairs may be raised and lowered from cab level or the ground and occupants can quickly exit with a conveniently located emergency egress ladder if the wheel dozer becomes inoperable. Wide walkways with non-skid surfaces and integrated lockout/tagout points are designed into the service areas.

MAXIMIZED VISIBILITY

The 854 offers several standard and optional features designed to improve visibility during operations. An optional pull-down window shade and heated mirrors ensure extended visibility for safe operation. Standard LED lights and cab-mounted LED warning beacons provide excellent workspace visibility. Optional Cat MineStar™ Detect includes Cat Vision plus an Object Detection System to enhance operator awareness around the machine. Object Detection combines radar and camera systems to warn operators about light vehicles or stationary hazards located behind their machines.



REDUCE YOUR DOWNTIME. REDUCE YOUR COSTS.

The 854 is designed to be easy to service and maintain — so your machines spend less time in the maintenance shop and more time on the job.

We've grouped maintenance points to minimize movement around the machine, provided swing-out doors on both sides of the engine compartment for easy access to important daily service checks, and provided ground-level or platform service access for fluids and key electrical controls. Ecology drains make service easier and help prevent spilling of potential environmental contaminants.

The standard VIMS™ monitoring system with an easy-to-view display delivers critical health and payload information, keeping performance at optimum levels and allowing advanced troubleshooting and planning to lower maintenance costs.



ADVANCED FILTRATION SYSTEM

This Advanced Filtration System extends the performance and reliability of your hydraulic system. The system includes:

- + Lift/tilt case drain filters
- + Lift/tilt high pressure screens
- + Steering case drain filters
- + Steering high pressure screens
- + Hydraulic case drain filters
- + Front pump drive lube filter
- + Front and rear brake oil screens.

HOSES & COUPLINGS

Hoses are critical components that carry the lifeblood of hydraulic equipment, so hose reliability can make a huge difference in your operation. That's why Caterpillar supplies its own OEM hoses, couplings and assembly kits. We do so because we want to make sure you get the safest, most dependable hoses possible.



A WHEEL DOZER YOU CAN COUNT ON



ROBUST STRUCTURES

The 854 features highly durable structures that achieve multiple lifecycles and withstand the toughest conditions. Full box-section frames absorb torsional forces during dozing, maintaining alignment for hitch pins and drive line. Spread hitch design features double tapered roller bearings and hardened pins that resist both horizontal and vertical loads.

We've enhanced strength in key pin areas through the use of one-piece castings, and solid one-piece push beams are through-width, not merely attached to the side of the frame. In corner dozing, stresses are transferred and absorbed through a larger portion of the frame. In addition, 90% of the machine structure is robotically welded to provide highly consistent welds and increased strength.



BUILT TO BE REBUILT

The 854 frame, powertrain, engine and components are all built to be rebuilt — using new, remanufactured or rebuilt parts and components — so you can take advantage of multiple lives of like-new performance at a fraction-of-new price.

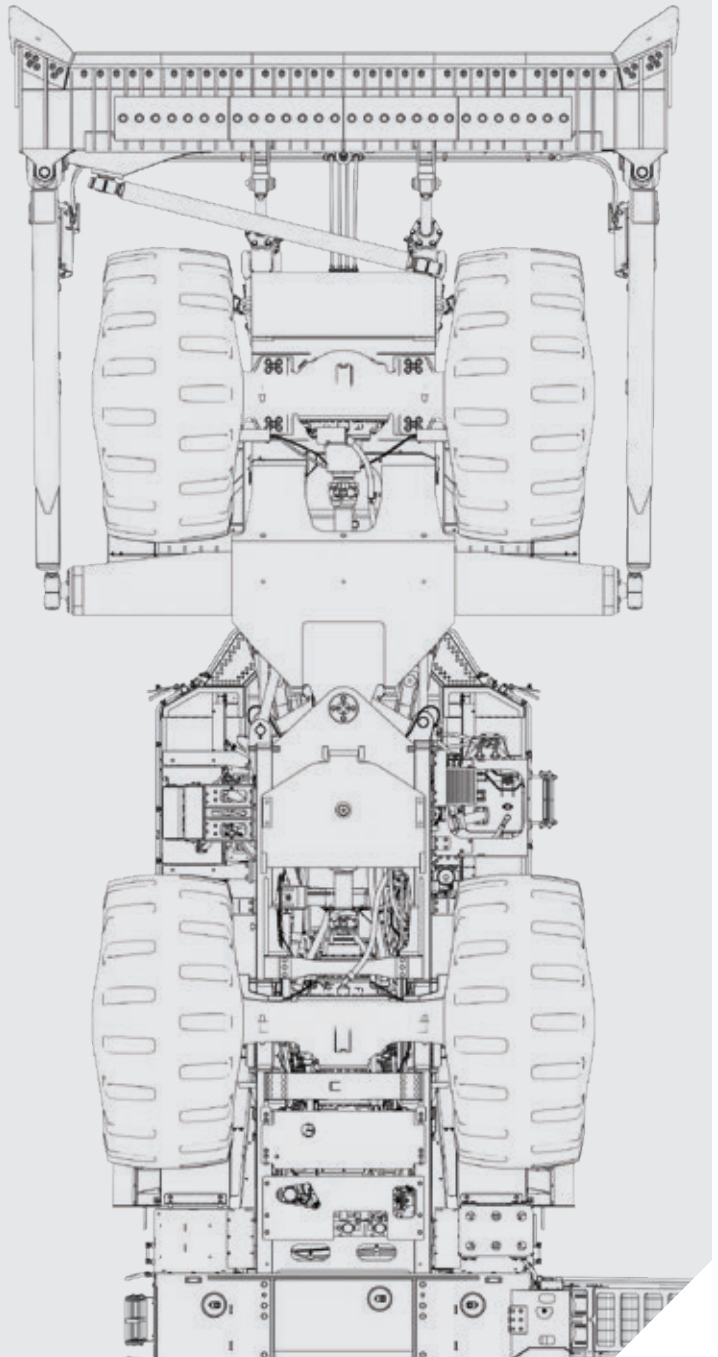

CAT BLADES: THE PERFECT MATCH FOR CAT WHEEL DOZERS

Decades of dozer research and development have made Caterpillar the leader in blade technology. Cat blades are designed for loadability and constructed of high-tensile strength materials to produce big numbers over a long life.

- + Optimal heel clearance and sharp cutting edge angle, which make the blade more aggressive in tough material
- + Superior loadability due to heavy moldboard construction and bolt-on hardened cutting edges and end bits
- + Ability to resist torsional bending and distortion
- + High-strength, pressed rib construction
- + Cat Large Dozer bolt-on cutting edges and bottom wear plates
- + Material thickness chosen specifically to increase wear resistance and dozing effectiveness — without sacrificing machine balance or performance
- + Optimized widths and capacities for excellent dozing and rolling characteristics





HEAVY-DUTY SEMI-U BLADE

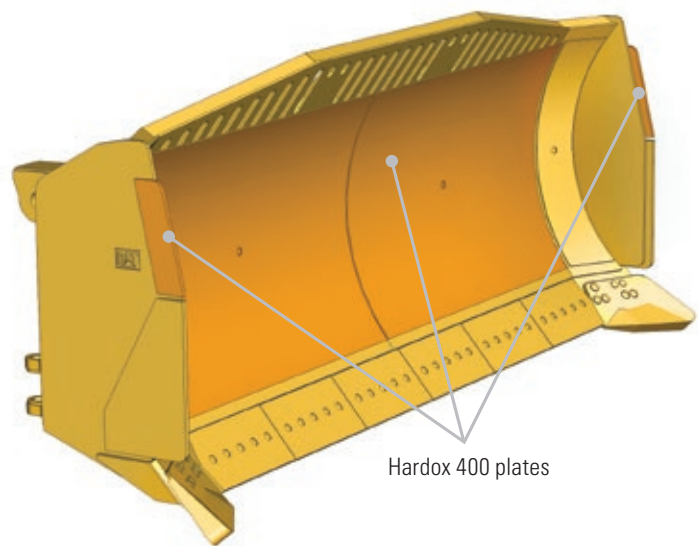

- + Unmatched durability in high wear applications
- + Hardox 400 Liner plate and side plates
- + Additional reinforcements on the bottom of the blade
- + Featuring the characteristics of the S and U blades in one package
- + Increased capacity while retaining excellent spreading characteristics of a straight blade

SMART MACHINE

MAXIMIZED PRODUCTIVITY

The 854 is integrated with electronics that provide flexible levels of information to both the site and the operator. This integration creates a smart machine and more informed operator, maximizing the productivity of both.



VITAL INFORMATION MANAGEMENT SYSTEM 3G (VIMS™ 3G)

VIMS 3G allows you to connect directly to the machine for access to a wide range of sensor information and enhanced machine data. You can create productivity reports with payload and work cycle segmentation; identify operator training needs through productivity data; access detailed data logging of machine parameters and diagnostic codes; and track machine sensor information with trend analysis and histograms to monitor machine health.

ADVISOR DISPLAY WITH OPERATOR PERSONALIZATION

An upgraded touchscreen Advisor Display features a large screen that provides intuitive operation and easy navigation. It keeps operators informed about machine systems to decrease service time. The Advisor Display enables operators to instantly recall personalized feature settings, decreasing set-up time for individual operators. Operators have access to productive cycle time and fuel usage information. Advisor Display can store up to 10 separate operator profiles.

GAIN AN EDGE

Cat wheel dozers leave the factory ready to take advantage of Cat MineStar™ Solutions, the mining industry's most comprehensive and thoroughly integrated suite of technology offerings. Fleet management, guidance technologies and machine health applications allow significant improvements in your operations and maintenance organizations. Safety technologies help keep people safe when they're in, on or around equipment.



FLEET

Provides comprehensive, real-time machine tracking, assignment and productivity management, delivering a comprehensive view of all operations from anywhere in the world.



TERRAIN

Provides real-time feedback on payloads and design plan progress to increase productivity and accuracy, reduce rework, enhance ore control and improve shift-to-shift operator performance.



DETECT

Offers a range of capabilities designed to assist the operator with areas of limited visibility around fixed and mobile equipment.



HEALTH

Delivers critical event-based machine condition and operating data and includes comprehensive equipment health and asset monitoring capabilities, with a wide range of diagnostic, analytic and reporting tools.

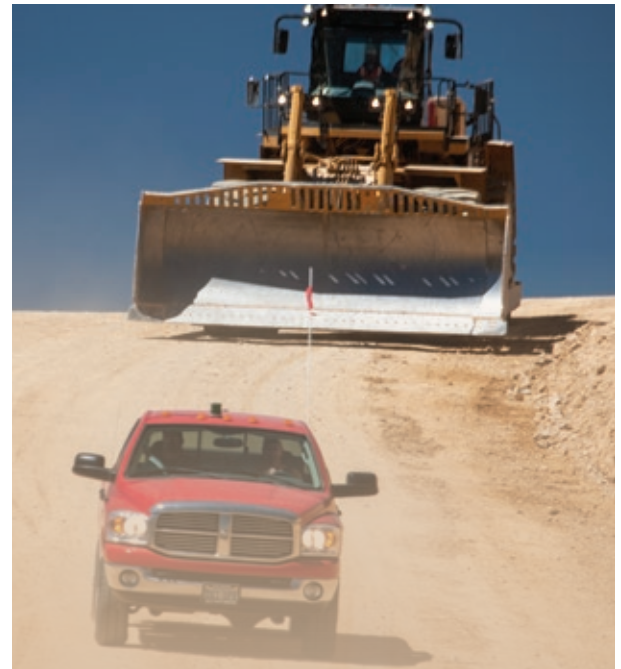

OBJECT DETECTION

Mobile equipment operators need to be keenly aware of their environment, especially when putting their equipment into motion. Cat MineStar Object Detection combines radar and camera systems to warn operators about light vehicles or stationary hazards located behind their machines. Available for the 854, the system improves operator awareness and enhances safety all around your site.

Object Detection is designed to increase safety and visibility during machine startup, initial movement and always in reverse. When radars are active, the system alarms only when the wheel dozer is in gear and in the direction of a detected object. The radars are always active in reverse. Once the wheel dozer reaches a speed threshold or distance traveled (customer-configured option), the radars enter a standby state. The system is configurable for continuous and discrete alarming methods.

MINING — FOR A — **BETTER WORLD**

Certain governmental regulations may mandate that you establish and follow environmentally sound policies and practices as you meet the demand for mined materials. We're focused on doing our part to make sure our wheel dozers help you meet those regulations. Every piece of Cat equipment is designed to be better and do better.

At Caterpillar, we continue to research alternative energy sources such as biofuels and liquefied natural gas and power options like electrification to find new ways to reduce emissions. In addition, we preserve raw materials, conserve energy and reduce emissions through the Cat Certified Rebuild and Cat Reman programs, which return end-of-life machines and components to like-new condition.

The 854 was designed to be more efficient and use less fuel, which reduces engine emissions and carbon footprint. Engine Idle Shutdown can help you save fuel by avoiding unnecessary idling. Fluids are better controlled through use of Cat anti-drain filter housings and component ecology drains. You can reduce waste, save energy and lower your overall costs by retrofitting your wheel dozer to incorporate efficiency improvements and emission reductions, and to keep them in production longer to conserve energy and minimize the need for raw materials.





PARTNERS IN YOUR PERFORMANCE

Our commitment to your success doesn't end when your Cat 854 begins pushing material. We immediately start looking for ways to make your wheel dozer work more efficiently, safely and productively. From addressing performance issues, to training operators and technicians, to calibrating onboard technologies — our support of your loader productivity is ongoing.

Caterpillar and Cat dealer personnel will partner with you on site to improve the performance not only of your wheel dozers, but of your overall loading and hauling operation. You'll have access to parts and service, and technicians who are focused on helping you optimize repairs to keep machines productive. And we help with training to ensure your operators have the skills and knowledge they need to work as efficiently and productively as possible.

We also work alongside you to ensure you achieve maximum value throughout the life of your equipment. Together with our Cat dealer network, we customize service offerings to provide a maintenance solution that fits your operation — whether you want to perform the majority of service yourself, or you're looking for an onsite partner to manage your maintenance organization. We're also consultants who can help you make smart decisions about buying, operating, maintaining, repairing, rebuilding and replacing equipment.

YOUR PARTNER FOR THE COMPLETE EQUIPMENT LIFECYCLE

No one knows more about how to get the most from a piece of Cat equipment than your local Cat dealer. This one-of-a-kind, on-the-ground support network delivers expert service, integrated solutions, after-sales support, fast and efficient parts fulfillment, world-class rebuild and remanufacturing capabilities, and more.

Cat dealers operate as more than 150 local businesses — each one fully embedded in and committed to the geographic area it serves. That means you work with people you know, who know your business, and who respond on your timeframe.

TECHNICAL SPECIFICATIONS

See cat.com for complete specifications.

ENGINE			
Engine Model	Cat C32B		
Rated Speed	1,750 rpm		
Emissions	U.S. EPA Tier 4 Final		
Gross Power – SAE J1995:2014	671 kW	900 hp	
Net Power ISO – 9249:2007	607 kW	814 hp	
Emissions	Tier 2 Equivalent		
Gross Power – SAE J1995:2014	676 kW	907 hp	
Net Power ISO – 9249:2007	614 kW	823 hp	
Bore	145 mm	5.7 in	
Stroke	162 mm	6.4 in	
Displacement	32.1 L	1,958 in ³	
Peak Torque at 1,200 rpm	4242 N·m	3,139 lbf·ft	
Torque Rise	30%		
+ Net power advertised is the power available at the flywheel when the engine is equipped with fan, air cleaner, muffler and alternator.			
+ Net torque rise meets SAE J139.			
+ No engine derating required up to 3050 m (10,000 ft) altitude.			

OPERATING SPECIFICATIONS			
Operating Weight	101 898 kg	224,647 lb	
Blade Capacities	30.5 - 44.8 m ³ 40 - 58.6 yd ³		

TRANSMISSION			
Transmission Type	Cat Planetary Power Shift		
Converter Drive Forward 1	7.1 km/h	4.4 mph	
Converter Drive Forward 2	12.4 km/h	7.7 mph	
Converter Drive Forward 3	21.2 km/h	13.2 mph	
Converter Drive Reverse 1	7.7 km/h	4.8 mph	
Converter Drive Reverse 2	13.5 km/h	8.4 mph	
Converter Drive Reverse 3	23.5 km/h	14.6 mph	
Direct Drive Forward 1	Lock-up disabled		
Direct Drive Forward 2	13.0 km/h	8.1 mph	
Direct Drive Forward 3	22.8 km/h	14.2 mph	
Direct Drive Reverse 1	8.0 km/h	5.0 mph	
Direct Drive Reverse 2	14.3 km/h	8.9 mph	
Direct Drive Reverse 3	25.1 km/h	15.6 mph	
+ Travel speeds based on 45/65-45 L-5 46 ply tires.			

HYDRAULIC SYSTEM – LIFT/TILT			
Output at 1,850 rpm and 6900 kPa (1,000 psi)	610 L/min	161 gal/min	
Cylinder, Double-acting: Lift, Bore and Stroke	177 mm × 1760 mm	0.58 ft × 5.8 ft	
Cylinder, Double-acting: Tilt and Tip, Bore and Stroke	267 mm × 286 mm	0.88 ft × 0.94 ft	
Relief Valve Setting – Bulldozer (Large Pump)	22 675 kPa	3,289 psi	
Relief Valve Setting – Tilt Cylinders (Small Pump)	24 560 kPa	3,560 psi	

HYDRAULIC SYSTEM – STEERING			
Steering System – Circuit	Pilot, load sensing		
Steering System – Pump	Piston, variable displacement		
Minimum Turning Radius (over blade)	9550 mm	31 ft	
Total Steering Angle	86 degrees		
Maximum Flow			
Relief Valve Setting	34 500 kPa	5,004 psi	

SERVICE REFILL CAPACITIES

Fuel Tank – Standard	1562 L	413 gal
Cooling System	200 L	53 gal
Crankcase	120 L	32 gal
Transmission	169 L	45 gal
Differentials and Final Drives – Front	369 L	98 gal
Differentials and Final Drives – Rear	342 L	90 gal
Hydraulic System – Implement and Brakes (tank only)	261 L	68.9 gal
Hydraulic System – Steering and Engine Cooling Fan (tank only)	290 L	77 gal

- + The Cat C32B engine is available in configurations that meet U.S. EPA Tier 4 Final emission standards or equivalent to U.S. EPA Tier 2.
- + Cat U.S. EPA Tier 4 Final diesel engines are required to use ULSD (ultra-low sulfur diesel fuel with 15 ppm of sulfur or less) or ULSD blended with the following lower-carbon intensity fuels*** up to:
 - + 20% biodiesel FAME (fatty acid methyl ester)*
 - + 100% renewable diesel, HVO (hydrotreated vegetable oil) and GTL (gas-to-liquid) fuels
- + Cat engines equivalent to U.S. EPA Tier 2, are compatible with diesel fuel blended with the following lower-carbon intensity fuels*** up to:
 - + 100% biodiesel FAME (fatty acid methyl ester)**
 - + 100% renewable diesel, HVO (hydrotreated vegetable oil) and GTL (gas-to-liquid) fuels
- + Refer to guidelines for successful application. Please consult your Cat dealer or “Caterpillar Machine Fluids Recommendations” (SEBU6250) for details.

* Engines with no aftertreatment devices can use higher blends, up to 35% biodiesel where mandated.

** For use of blends higher than 20% biodiesel, consult your Cat dealer.

*** Tailpipe greenhouse gas emissions from lower-carbon intensity fuels are essentially the same as traditional fuels.

AIR CONDITIONING SYSTEM

The air conditioning system on this machine contains the fluorinated greenhouse gas refrigerant R134a (Global Warming Potential = 1430). See the label or instruction manual for identification of the gas.

If equipped with 1234yf (Global Warming Potential = 0.501), the system contains 2.1 kg of refrigerant, which has a CO₂ equivalent of 0.001 metric tonnes (2.2 lbs).

If equipped with 134a (Global Warming Potential = 1430), the system contains 1.8 kg (4.6 lb) of refrigerant, which has a CO₂ equivalent of 3.003 metric tonnes (3.31 tons).

AXLES

Front	Fixed
Rear	Trunnion
Oscillation Angle	±10 degrees

BRAKES

Brakes	Meets ISO 3540:2011
--------	---------------------

CAB

	Standard	Suppression
Operator Sound Level (ISO 6396:2008)	71 dB(A)	70 dB(A)
Machine Sound Level (ISO 6395:2008)	116 dB(A)	113 dB(A)

- + The machine sound power level was measured according to ISO 6395:2008. The measurement was conducted at 70% of the maximum engine cooling fan speed.
- + The operator sound pressure level was measured according to ISO 6396:2008. The measurement was conducted at 70% of the maximum engine cooling fan speed.
- + Hearing protection may be needed when the machine is operated with a cab that is not properly maintained or when the doors or windows are open for extended periods or in a noisy environment.

CAB

Rollover Protective Structure (ROPS)/ Falling Object Protective Structure (FOPS)	ISO 3471:2008 and ISO 3449:2005 Level II Standards
---	---



854 WHEEL DOZER

For more complete information on Cat products, dealer services and industry solutions, visit us at www.cat.com

PEDJ1295-01

Materials and specifications are subject to change without notice. Featured machines in photos may include additional equipment. See your Cat dealer for available options.

© 2025 Caterpillar. All Rights Reserved. CAT, CATERPILLAR, LET'S DO THE WORK, their respective logos, "Caterpillar Corporate Yellow", the "Power Edge" and Cat "Modern Hex" trade dress as well as corporate and product identity used herein, are trademarks of Caterpillar and may not be used without permission.

