



# R1700 UNDERGROUND LOADER RIG OUT CATALOG

UPGRADE, REPAIR & REBUILD KITS

**LET'S DO THE WORK.™**



## CONTENTS

### UPGRADE KITS

REMOTE CONTROL KITS.....	3
PRODUCT LINK™ ELITE.....	4
CPM PAYLOAD.....	4
AUTODIG.....	5
RADIATOR ALTERNATIVE.....	5
SEAT BELT REMINDER.....	6
TIRE PRESSURE MONITOR.....	6
QUIET STIC STEERING VALVE.....	7
ENGINE PRECLEANER.....	7
WHEEL CHOCKS.....	8
CAB LINER KIT.....	8
AUTOLUBE.....	9

### SAFETY AND VISIBILITY

REAR VIEW CAMERA.....	11
CENTRAL LOCKOUT AND SERVICE PANEL.....	11
SERVICE PINS.....	12
LINK PINS.....	12
HITCH ARTICULATION & CONTROL PINS.....	13
FAST FILL FUEL.....	13
RECOVERY HOOK (TOW).....	14
HANDRAILS.....	14
LED LIGHTS.....	15
SERVICE BAY AND TRUCK LOADING LIGHTS.....	16
LIGHT GUARD (PERSPEX).....	17
WINDOW GUARD.....	17
CAB WEAR BARS.....	17
DUAL PANE WINDOWS.....	18
MUDGUARDS (FENDERS).....	18

### REPAIR & REBUILD KITS

ACCUMULATOR SEAL KITS.....	20
AFTERTREATMENT KITS.....	20
ALTERNATOR REPAIR KITS.....	20
BRAKE PEDAL KITS.....	20
CAB WIPER BLADE.....	20
SEAT KITS.....	21
FUEL CAP FILTER KIT.....	23
FUEL DRAIN KITS.....	23
HYDRAULIC PUMP KITS.....	23
INJECTOR HARNESS KIT.....	23
PILOT FILTER SEAL KIT.....	23
SOLENOID KITS.....	23
STARTER REPAIR KITS.....	24

### ENGINE REBUILD

GASKET & SEAL.....	25
ELECTRICAL DT CONNECTORS.....	26

### MAINTENANCE

CAT GREASES.....	27
COOLANTS.....	27

### BUCKETS & GROUND ENGAGING TOOLS

BUCKETS.....	29
DURILOCK™ LIP SHROUD SYSTEM.....	30
BOLT ON HALF-ARROW GET.....	31
MODULAR SEGMENT SYSTEM.....	31

EXPECT MORE FROM THE NEXT GENERATION

## THE CAT® R1700

ENGINE POWER: STAGE V: 257 kW / 345 hp; VR, Tier3 : 269 kW / 361 hp

GROSS MACHINE MASS: 62 739 kg / 138,316 lb

BUCKET CAPACITIES: 5.7-8.6 m³ (7.5-11.2 yd³)

PAYLOAD: 15 000 kg / 33,069 lb

The Cat® R1700 underground mining loader is a huge leap forward in LHD design, technology integration and diesel emission controls. It is a powerful tool for underground mining.



#### IMPROVED FUEL EFFICIENCY

MADE POSSIBLE BY THE CAT C13 ENGINE AND ULTRA-EFFICIENT HYDRAULICS.

#### INCREASED CAPACITY

TRUE 15-TONNE (16.5-TON) LOADER THAT IS A PERFECT 3-PASS MATCH WITH THE CAT AD45 UNDERGROUND TRUCK

#### MORE LIFT FORCE

NOTICEABLE POWER AND PERFORMANCE INSIDE THE PILE – DELIVERING QUICK LOADING CYCLES

Disclaimer: The figures quoted are an indication only and can vary greatly site by site dependent on application, maintenance and fuel consumption.



## REMOTE CONTROL KITS

This enables line-of-sight remote control, increasing safety by removing operators from hazardous environments to safer locations with less risk.

NUMBER	NAME	DESCRIPTION	SI / REFERENCE #
467-3570	Control Ar	Provides onboard wiring and receiver for Command, Requires: 496-2856 INTERFACE, REMOTE	M0103879
472-8745	Control Ar	Provides full control and supervision over vehicle; operator remotely controlled	
<b>SELECT REQUIRED REMOTE OPERATOR CONSOLE</b>			
557-3851	COMMAND CONSOLE LOS STD	Transmitter Kit: Standard joystick configuration for implement and motion control	—
557-3852	COMMAND CONSOLE LOS ALT1	Transmitter Kit: Alternative implement and standard motion control	
557-3853	COMMAND CONSOLE LOS ALT2	Transmitter Kit: Alternative implement and alternative motion control	



## PRODUCT LINK™ ELITE

Product Link™ Elite system boosts connectivity and increases the availability of data provided by the R1700. It enables the loader to collect and transmit information into locally hosted or cloud-hosted applications such as MineStarHealth Office, Health Equipment Insights, Equipment Care Advisor or VisionLink®.

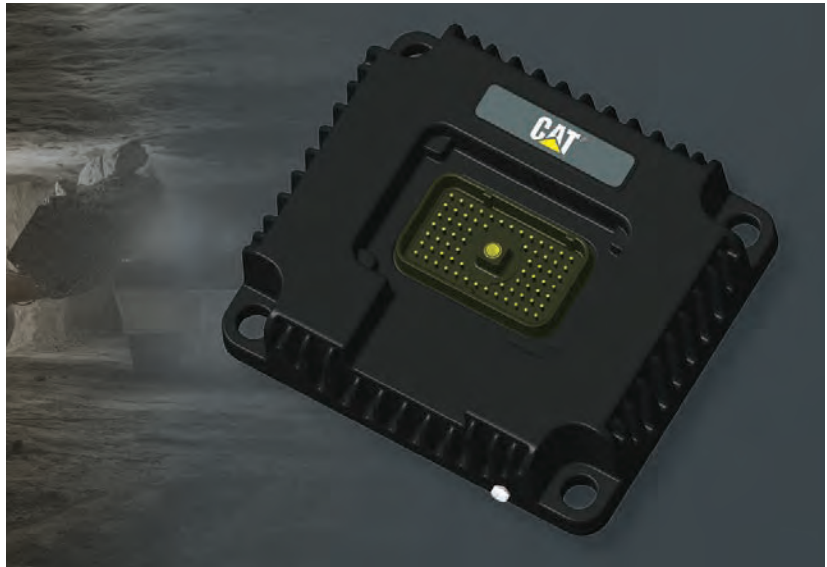

NUMBER	NAME	DESCRIPTION	SI / REFERENCE #
491-0349	CONTROL GP	Product Link™ enables the remote transmission of information about the operation, and condition of your equipment	M0094277



## CPM PAYLOAD

Cat Production Measurement is a productivity enhancing Cat® Connect PAYLOAD technology that helps operators consistently deliver payloads with world-class weighing precision, in line with the leading payload scale specialists. CPM includes an integrated onboard payload weighing scale with material management, cycle count & time recording and wireless production detail reporting capability. Payload & cycle totals can be sent wirelessly (requires OP-4689 PRODUCT LINK™, WI-FI)

NUMBER	NAME	SI / REFERENCE #
472-8741	CPM PAYLOAD SOFTWARE	M0075618

## AUTODIG

Autodig is a software enabled attachment that controls the implement system during the bucket loading portion of a cycle to automatically load material. Ideal for inexperienced operators and remote machine operation.



NUMBER	NAME	SI / REFERENCE #
472-8744	CONTROL AR	M0074237 SEBU9952 - Operation Section - Autodig System

## RADIATOR ALTERNATIVE

A high efficiency radiator, featuring a modular design with individual tubes that can be serviced independently to reduce maintenance. More resistant to clogging which allies for faster clean outs and increased duration between servicing.



NUMBER	NAME	SI / REFERENCE #
480-5255	Radiator Gp	M0076660 Cooling System Package

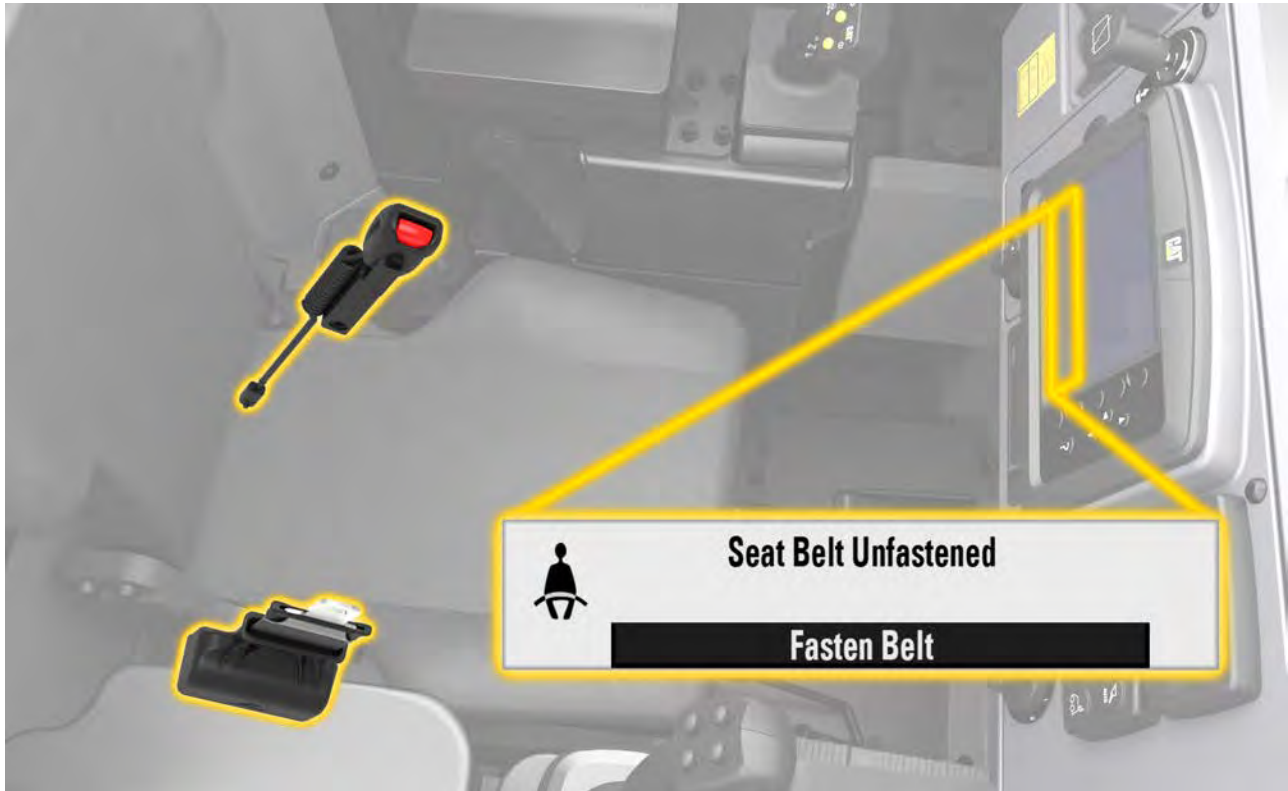

## SEAT BELT REMINDER

The Cat Seat Belt Reminder for operator seats provides both an audible and visual warning to remind the operator when the seat belt is not latched when the parking brake is off and the machine begins to move.

NUMBER	NAME	SI / REFERENCE #
513-5984	Installation Group	REHS7361
500-8869	Light & Alarm	

## TIRE PRESSURE MONITOR

Tire pressure monitoring system (TPMS) provides early warning of pressure loss in one or more tires. Wireless sensors inside each tire provide real time, temperature compensated pressure values, and will trigger alerts to the operator in the event of under inflation or rapid decompression. Compatible with Electronic Technician and Product Link™. Only use for use with: 4750563 Rims, Tubeless set of (4)

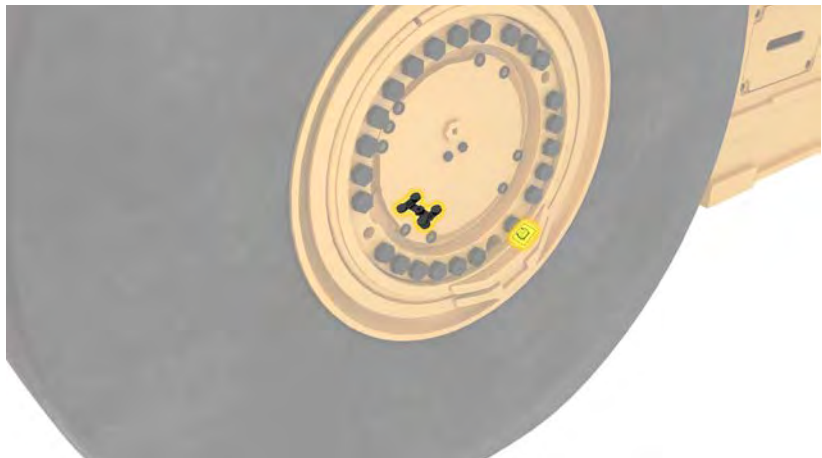

NUMBER	NAME	SI / REFERENCE #
571-0004	Control AR	M0116669, M0074184

## QUIET STIC STEERING VALVE

The new quiet STIC steering valve significantly reduces operator sound levels achieving quieter steering operation while maintaining the same feel for the operator.

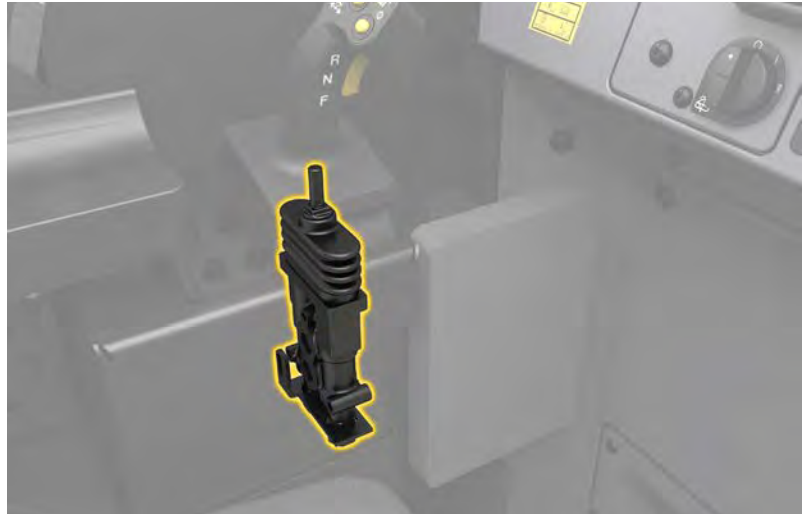

NUMBER	NAME	SI / REFERENCE #
481-0537	Quiet STIC Steering Valve	M0070988 Systems Operation - Pilot Valve (STIC Steering)

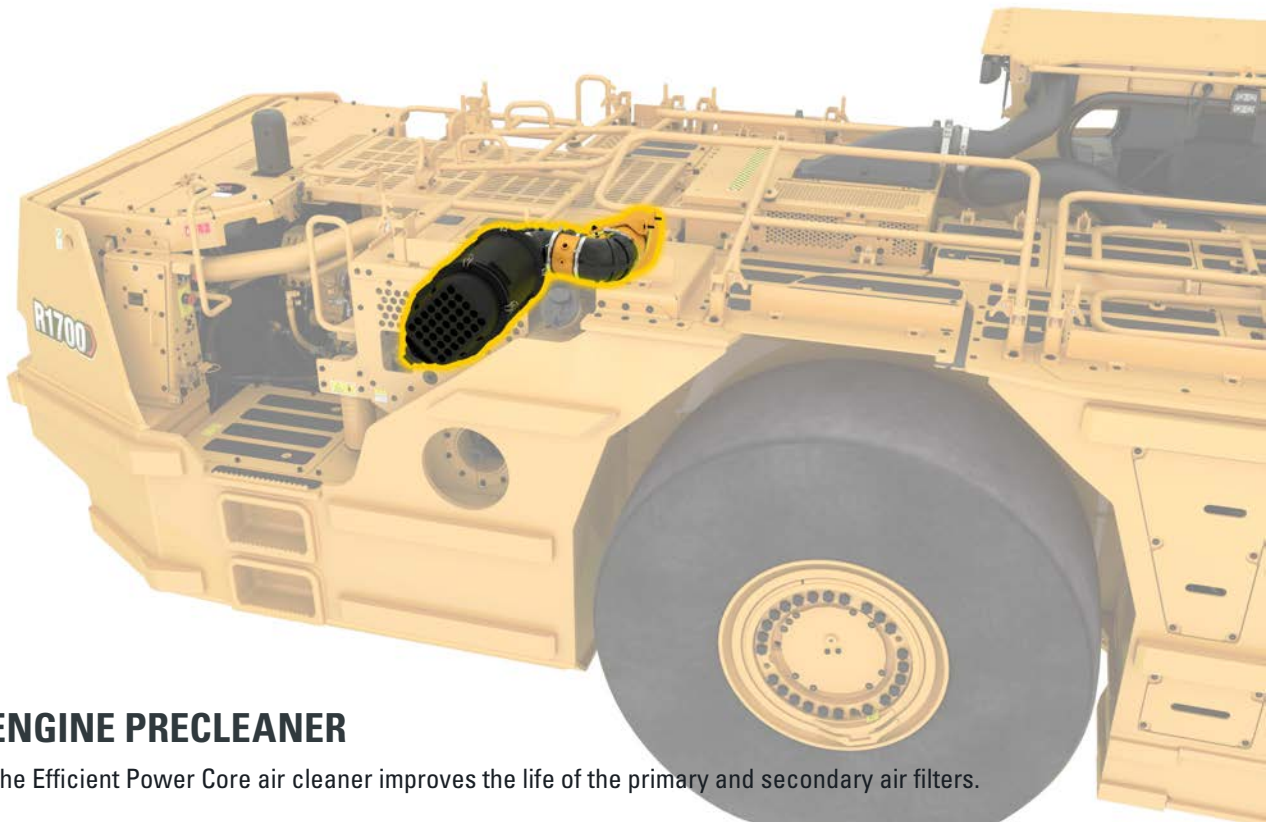

## ENGINE PRECLEANER

The Efficient Power Core air cleaner improves the life of the primary and secondary air filters.

NUMBER	NAME	SI / REFERENCE #
480-8705 (1-442) 630-0312 (443-UP)	CLEANER GP-AIR	—
480-8798 (1-453) 629-9926 (454-UP)	CLEANER GP-AIR	—

## WHEEL CHOCKS

Provides the customer with Wheel Chocks and an Integrated Storage solution. Wheel chocks are used to prevent the machine from rolling when parked by securing a wheel.

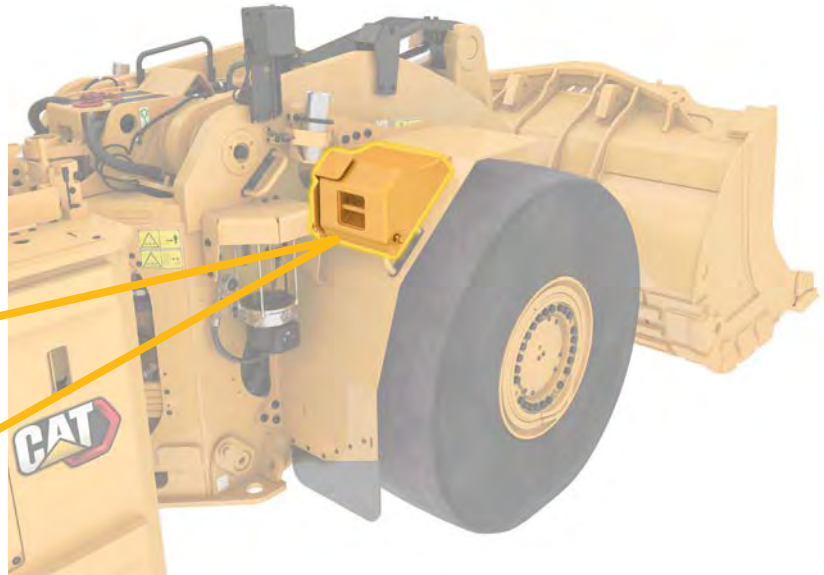

NUMBER	NAME	SI / REFERENCE #
617-4671 (438-UP)	CHOCK GP - WHEEL	SEBU9952 Operation Section - Use of Wheel Chocks

## CAB LINER KIT

The Cab internal acoustic liners are made of reliable and durable material that is fire retardant, thus promoting safety.

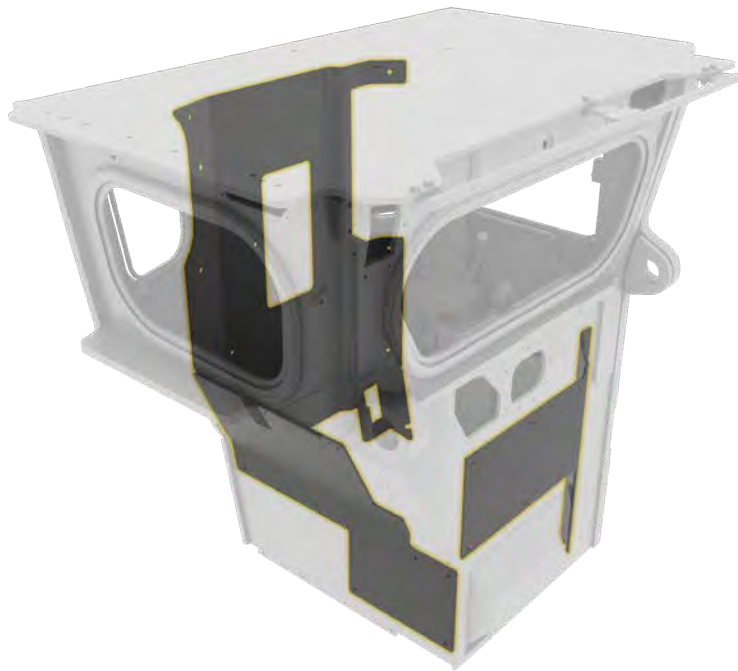

NUMBER	NAME
482-8442	LINER GP - CAB SOUND SUPPRESSION (refer PEJJ0354 in Cat Dealer)



# AUTOLUBE

The optional Cat® Auto Lube System provides precise, automatic lubrication of pins and bushings while the machine is in operation. Automatic lubrication reduces time spent on daily maintenance and downtime for unplanned repairs due to insufficient greasing. This helps to increase productivity while driving down owning and operating costs.



## AUTOLUBE

Provides an automated and controlled system to dispense lubrication, including hardware and guarding, for field installation of the autolube system OR Automatic central lubrication system with integrated monitoring and diagnostics that is fully integrated into the machine and all lines are prefilled with grease. Integrated Autolube extends component and service life. Pumps are designed to be out of the way to stay protected, while still allowing ground level refilling.



NUMBER	NAME	SI / REFERENCE #
467-1779	Lubrication Arrangement	M0080995



**KEEP OPERATORS**

# SAFE, COMFORTABLE & IN CONTROL

### DESIGNED FOR COMFORT

The cab on the R1700 maintains the same footprint as previous generations; however, the interior has been completely redesigned with new space allotment for the operator and all new electronic components. The operator sits slightly lower inside the cab for improved ride quality and head room.

- Adjustable padding for the operator's knees and additional foot-space during pedal operation
- Improved ergonomics on all controls, plus easy-to-use joystick controls
- Isolation-mounted cab to reduce vibration transfer to the operator
- Optional dual pane windows for reduced noise and improved temperature control in extreme ambient conditions

### DESIGNED FOR SAFETY

With two emergency exits, improved camera options, in-cab fire suppression activation and more, the R1700 is built with the safety of your people in mind. The operator present system door sensor and latch sensor help ensure the safety of anyone working in, on or around the machine by preventing startup with no operator in the cab.

### INFORMATION DISPLAYS

A high-resolution display gives operators real-time system information in 11 different languages, keeping them up to date on performance and machine status even before the motor starts. The display can be integrated into your mine's communications network and comes ready for Product Link™ Elite data analysis and Cat MineStar™ connectivity.

### DESIGNED FOR RESPONSIVENESS

During the load or dump cycle, the harder the operator pushes the controls, the faster the machine responds. Performance is also enhanced by automated loading of the bucket with the Auto Dig feature. In addition, the steering system is pilot controlled to provide more acute feel for the operator as they maneuver in tight places.

# SAFETY & VISIBILITY »

## REAR VIEW CAMERA

Provides a colour camera used to show the view behind the machine and enhance the operators visibility of his surroundings. The single camera system is compact, rugged, reliable and extremely simple to use. The colour camera mounted on the rear of the machine, is connected to an LCD display mounted to the front dash on the right hand side.



NUMBER	NAME	SI / REFERENCE #
469-8644	Camera Arrangement	SEBU9952 Operation Section - Camera



## CENTRALIZED LOCKOUT AND SERVICE PANEL

For maintenance that DOES NOT require the engine to be running. Use engine shutdown switch to stop the engine from the ground level. Battery disconnect switch provided to deactivate the electrical system. Use emergency stop switch to stop the machine from the ground level. The engine will stop, the parking brake will engage, and the implement and steering control will disable.

NUMBER	NAME	DESCRIPTION	SI / REFERENCE #
489-2520	PANEL GP-ELECTRONIC	Ground level service and maintenance switches	SEBU9952 Operation Section - Battery, Emergency Stop, Engine Shutdown, Engine Lockout
472-0663	WIRING GP-SHUTOOFF	Provided to deactivate the electrical system	

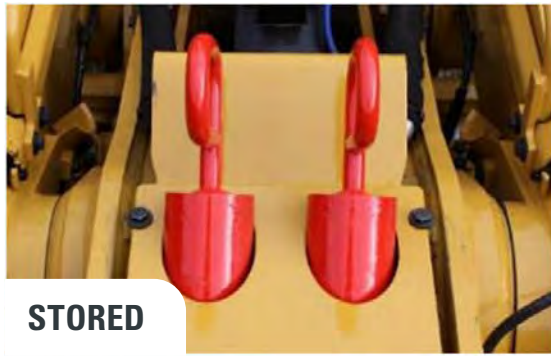

**STORED**



**INSTALLED**

## SERVICE PINS

Bucket control group safety pins allow maintenance personnel to safely service the loader with the bucket lift arms raised.

NUMBER	NAME	DESCRIPTION	SI / REFERENCE #
507-5478	COVER GP	Standard Bucket	M0084637
507-5479	COVER GP	Ejector Bucket	Lift Arm Support Pins



**STORED**



**INSTALLED**

## LINK PINS

The articulation lock pin allows maintenance personnel to safely service the loader near the articulation joint.

NUMBER	NAME	SI / REFERENCE #
491-6030	LINK GP	M0084637 Steering Frame Lock

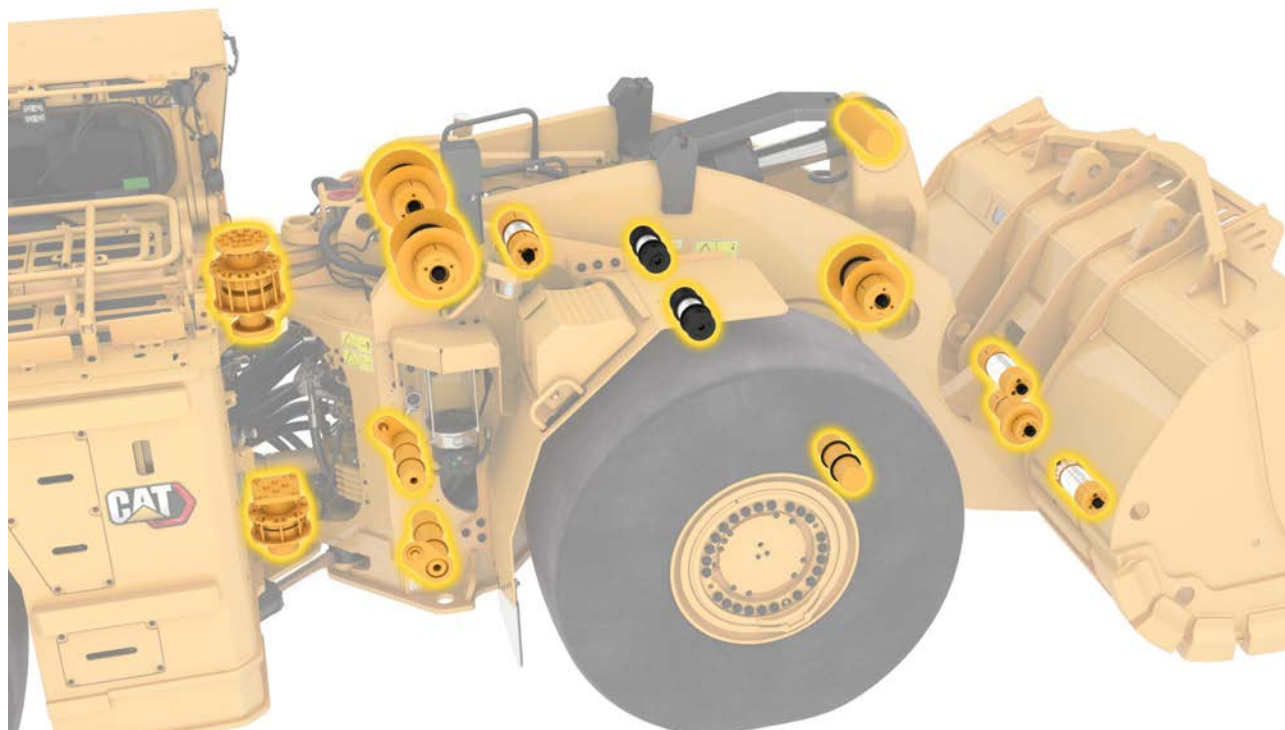

## HITCH ARTICULATION AND CONTROL PINS

Cat® linkage pins are designed to meet strict standards and are quality tested to ensure more time between replacements, which means less downtime and more savings in the long run.

NUMBER	NAME	SI / REFERENCE #
344-9995 (1-348)	HITCH GP-ARTICULATING	M0067832
621-7787 (349-UP)	HITCH GP-ARTICULATING	Articulating Hitch
484-2061	PIN GP-SEAL	M0067832 Bucket Control

## FAST FILL FUEL

A fast fill fuel system allows speedy refueling of vehicles and increases operator safety. Provides ground level gravity and ground level accessible fast fill feature with automatic shut-off for fast fill fueling. Reduces the risk of spills and overfilling.



NUMBER	NAME
467-1765 (1-443)	ADAPTER GP-FAST (FUEL FILL)
615-3718 (444-UP)	ADAPTER GP-FAST (FUEL FILL)



## RECOVERY HOOK (TOW)

A bolt on system, the brake release system is used to recover the machine from a slope or dangerous area. If the parking brake is engaged due to a machine fault, the brake release system can be used to disengage the parking brake to enable the machine to be towed.

INCLUDES Brake Release & Fixed Rear Mounted Protective Plate and Hook Arrangement.

NUMBER	NAME	SI / REFERENCE #
467-1797	BRAKE AR-RELEASE	SEBU9952
467-1818	BRAKE AR-RELEASE (US)	Operation Section - Brake Release

## HANDRAILS

Handrails provide extra protection for personnel when accessing the top deck of the machine.



NUMBER	NAME	SI / REFERENCE #
467-1823 (1-454) 630-3809 (455-UP)	HANDRAIL GROUP	SEBU9952 Operation Section - Handrails
467-1819 (1-453) 630-1956 (454-UP)	HANDRAIL GROUP	
522-8184	HANDRAIL GROUP	
551-0868	HANDRAIL ASSEMBLY	



## LED LIGHTS

EU compliance Hi/Low beam, LED standard fit, Manual or Auto Directional Switching mode, RHS upper cab light.

NUMBER	NAME
490-8887	LIGHTING GP-FLOOD (HIGH BEAM)
490-0888	LIGHTING GP (LOW BEAM)
480-4997	LIGHTING GP (LOW CAB)
484-9707	LIGHTING GP-CAB

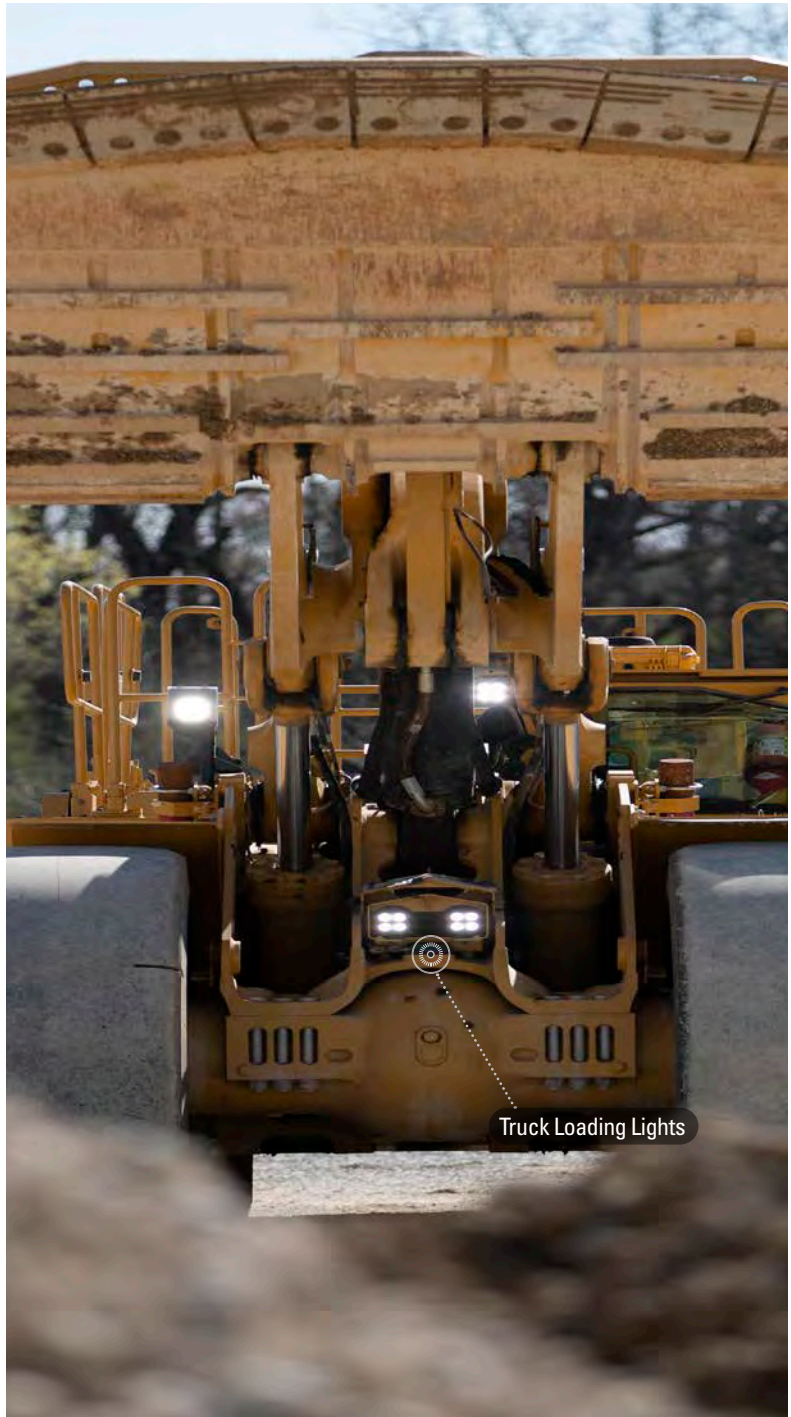

## SERVICE BAY AND TRUCK LOADING LIGHTS

Light mounted to cab to illuminate the service bay area. Dual light group including guard surround, mounted on the front of the NEEF to better illuminate the work area when truck loading.

NUMBER	NAME
491-0989	LIGHTING GP (TRUCK LOADING)
484-9708	LIGHTING GP-SERVICE





### LIGHT GUARD (PERSPEX)

Clear perspex light protectors for lift arm and NEEF lights.

NUMBER	NAME
472-0658	GUARD GP-LIGHT



### WINDOW GUARD

Steel guard to provide protection for rear side quarter window.

NUMBER	NAME
472-0660	GUARD GP - WINDOW



### CAB WEAR BARS

Bars mounted to side of cab to provide extra abrasive wear protection.

NUMBER	NAME
472-0655	BAR GP-WEAR



## DUAL PANE WINDOWS

Provides improved cabin insulation for extreme ambient temperatures and noise reduction.

NUMBER	NAME
467-1748	WINDOW GP-CAB

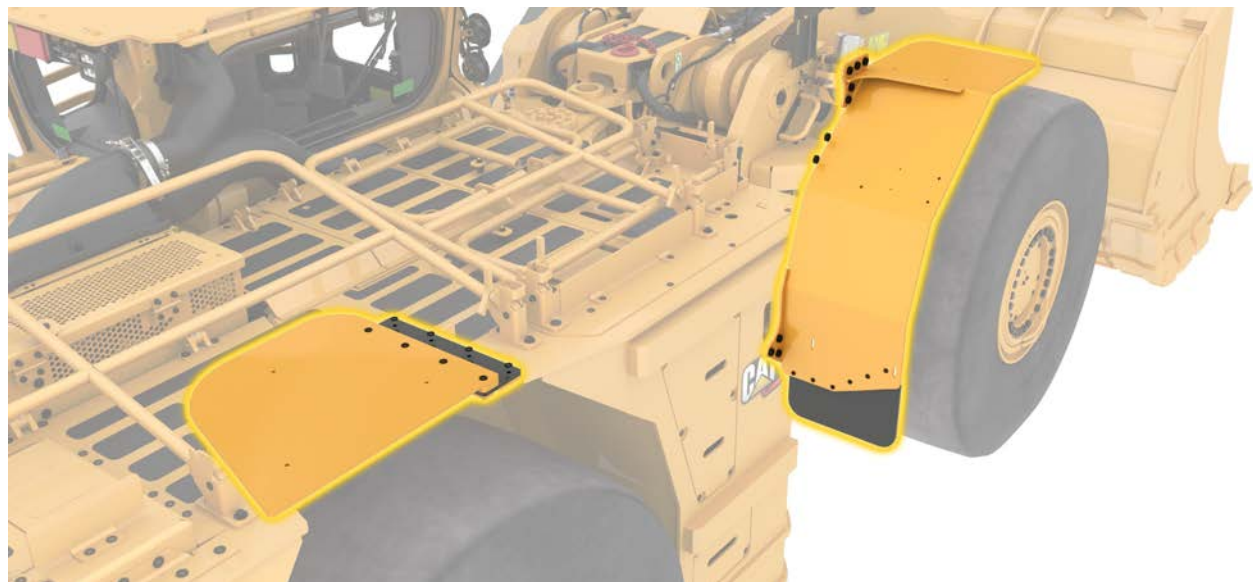

## MUDGUARDS (FENDERS)

Prevents tire debris from getting on the cab, platform and steps.

NUMBER	NAME
484-1590	FENDER GP-REAR
484-1580 (1-167)	FENDER GP-FRONT
572-7516 (168-UP)	FENDER GP-FRONT

# R1700

## REPAIR & REBUILD KITS

Cover essential elements of underground loader maintenance with these convenient repair and rebuild kits.



## ACCUMULATOR SEAL KITS

NUMBER	NAME	DESCRIPTION
170-0493	PISTON KIT	6" Seal Kit with Standard Seal
450-9200		6" Piston Kit with Extreme Seal

## AFTERTREATMENT KITS

NUMBER	NAME	DESCRIPTION
582-7467	FILTER KIT	DPF Filter Kit
20R-3666		Reman Filter Kit for 582-7467
20R-8034		Reman Filter Kit for 582-7467
390-0666	INLET AS KIT	Inlet Kit for DPF Filter
390-0677	OUTLET AS KIT	Outlet Kit for DPF Filter
473-5508	STRAP KIT	Contains hardware for DPF Tank Strap

## ALTERNATOR REPAIR KITS

NUMBER	NAME	DESCRIPTION
478-4961	COLLAR KIT	Repair kit for Alternator
478-4963	HARDWARE KIT	Repair kit for Alternator
478-4964	TERMINAL KIT	Repair kit for Alternator (terminal - holder assembly, plate, insulation, pin, grommet, and nut)
478-4967	TERMINAL KIT	Repair kit for Alternator (terminal - insulation, washers, and nut)
478-4962	BEARING KIT	Repair kit for Alternator

## BRAKE PEDAL VALVE

NUMBER	SI / REFERENCE #
117-7799	Brake Pedal valve repair seal kit
276-3239	Throttle Pedal Repair Kit
227-6783	Pedal Pin Repair Kit
300-4868	Kit-Roller Pin

## CAB: WIPER BLADE

NUMBER	DESCRIPTION
6V-5849	Wiper Blade replacement
6V-5851	Wiper Blade replacement
128-5040	Wiper Blade replacement

## CAB: SEAT KITS

NUMBER	NAME	DESCRIPTION
172-6995	COVER KIT	Tee Seat - For use with seat 586-2784
446-0637	CUSHION KIT	Kits provide easy field service, repair, or replacement of rugged Cat suspension seat systems. For use with seat 467-1743
370-8065 (1-195)	SHOCK KIT	Used to repair or replace shock absorbers on the seat suspension assembly
212-7779	SHOCK ABSORBER KIT (SEAT SUSPENSION)	Used to repair or replace shock absorbers on the seat suspension assembly
192-7799	VALVE AIR KIT	Used to repair or replace air suspension pressure valves used for height adjustment on heavy duty Cat suspension seats.
370-8066 (1-195)	AIR SPRING KIT	Replacement kit which provides cushion for the seat suspension. Also, provides an operator weight adjustment.
370-8070 (1-195)	RIDE IND KIT	Replacement kit which indicates the proper height for seat suspension.
452-6716	COMPRESSOR KIT	Provides a replacement compressor used in air seat suspension assemblies of rugged Cat suspension seat systems.
194-4286 (196-UP)	KIT-VALVE	Used to repair or replace valves used on the seat suspension assemblies of rugged Cat suspension seat systems.
194-4284 (196-UP)	COMPRESSOR KIT	Used to repair or replace the compressor used on the seat suspension assemblies of rugged Cat suspension seat systems.
370-8067 (1-195)	COMPRESSOR KIT	Replacement kit which provides compressed air for the seat suspension cushioning and adjustment.
186-9828 (196-UP)	SEAT KIT	Replacement kit to provide coverage to the suspension of the seat. Helps to prevent debris from entering the suspension and limit pinch points.
370-8068 (1-195)	SWITCH KIT	Toggle valve to control air pressure for proper weight adjustment for the seat suspension
213-5170	RIDE KIT	Used to service or replace the ride indicator used on rugged Cat suspension seat systems.
436-1688	PAN TILT KIT	Replacement kit that provides pivot support for the seat pan tilt adjustment
443-8573	HANDLE KIT	Replacement kit that provides operator handles to adjust the fore/aft and back pan tilt adjustments
488-2137	RECLINER KIT	Replacement kit of seat suspension structure for vertical travel
194-4283 (196-UP)	SPRING AIR KIT	Replacement kit which provides cushion for the seat suspension. Also, provides an operator weight adjustment. (Tee Seat)
192-7810	SPRING AIR KIT	Replacement kit which provides cushion for the seat suspension. Also, provides an operator weight adjustment. (High Back Seat)
173-7035	BLOCK SLIDER KIT	Provides wear blocks to allow seat fore/aft sliding adjustment, also includes stop hardware to limit travel.
110-5066 (196-UP)	BUMPSTOP KIT	Replacement kit used to service or repair the bump stops that limit seat movement of rugged Cat suspension seat systems.
370-8064 (1-195)	BUMPER KIT	Replacement kit which provides soft end travel stop of the seat suspension.
498-4463	LITERATURE HOLDER KIT	Pouch that allows storage of the OMM on the back of the seat
186-8762 (196-UP)	SEAT RAISER KIT	Replacement kit which indicates the proper height for seat suspension.
436-1687	LATCH KIT	Replacement kit that provides locking of the fore/aft adjustment on the seat
352-4796 (1-195)	BOOT KIT	Replacement kit to provide coverage to the suspension of the seat. Helps to prevent debris from entering the suspension and limit pinch points.
370-8156 (1-195)	BEARING KIT	Replacement kit for pivot joints on seat suspensions.
509-9889 (1-195)	SLIDE KIT	Provides wear blocks to allow seat fore/aft sliding adjustment, also includes stop hardware to limit travel.
194-4282 (196-UP)	SHOCK ABS KIT	Replacement shock for the seat suspension which limits the vibration to the operator during machine use.
295-4991 (196-UP)	FOAM KIT (BACK)	Foam replacement kit for operator cushions - Back
295-4992 (196-UP)	COVER KIT (BACK)	Cover replacement kit for operator cushions - Back
295-4993 (196-UP)	FOAM KIT (BASE)	Foam replacement kit for operator cushions - Base
295-4998 (196-UP)	COVER KIT (BASE)	Cover replacement kit for operator cushions - Base

## SEAL KITS

NUMBER	DESCRIPTION
360-0518	Seal Kit: Brake Accumulator Relief Valve
484-2690	Seal Kit: Brake Accumulator Relief Valve
1G-5928	Seal Kit: Pilot Valve for Steering
521-8356	Seal Kit: Relief Valve Group for Steering
166-0321	Seal Kit: Control Valve Group for Parking Brake
315-7866	Seal Kit: Control Valve Group for Air Conditioning
141-0888	Seal Kit: Pump Inlet Valve for Air Conditioning
293-8350	Seal Kit: Pump Control Valve Group for Air Conditioning



## FUEL CAP FILTER KIT

NUMBER	DESCRIPTION
350-7735	Cat filter kit provides a filter cartridge to prohibit water penetration into filter media of the filter assembly mounted on a fuel cap or fuel tank.

## FUEL DRAIN KITS

NUMBER	DESCRIPTION
432-4252	Metal drain is a mechanical device used to release excess or unwanted quantities of liquid from the fuel and water separator filter.

## HYDRAULIC PUMP KITS

NUMBER	DESCRIPTION
492-4554	Kit is for servicing a failed pump or rebuild/refurbish a worn piston pump. Used in the Main Hydraulic pump.
492-4556	Kit is for servicing a failed piston pump valve. Used in the Main Hydraulic pump.
648-2581	Kit is for servicing a failed pump or rebuild/refurbish a worn pump. Used in gear pumps of secondary steering systems.
204-0156	Kit is for servicing a failed pump or rebuild/refurbish a worn pump. Used in gear pumps of axle cooling.

## INJECTOR HARNESS KIT

NUMBER	DESCRIPTION
278-6394	Service part for injector harness - allows to replace part of the harness without having to replace the entire injector harness - Refer M0132787

## PILOT FILTER SEAL KIT

NUMBER	DESCRIPTION
369-7506	Replacement oil filter seal kit

## SOLENOID KITS

NUMBER	DESCRIPTION
277-8873	Seal Kit - Solenoid Valve 519-0843
332-5669	Seal Kit - Solenoid Valve 333-8242, 314-9274
426-4823	Seal Kit - Solenoid Valve 397-9397
291-5742	Seal Kit - Solenoid Valve 442-1607

## STARTER REPAIR KITS

NUMBER	NAME	DESCRIPTION
3N-3763	Terminal Kit	Repair kit for Starter Motor (Includes bushings and washers)
352-7994	Switch Kit	Repair kit for Starter Motor (includes: starter relay switch assembly, jump start protection cover, bolts, anchor and clamp.
533-1539	Seal Kit	Seal Kit for Starter Motor





# R1700

## ENGINE REBUILD



### GASKET & SEAL KITS

NUMBER	DESCRIPTION
473-2594	Rear Structure
473-2197	Water Pump Installation
248-1394	Single Fuel Injector
567-7509	Central and Lower Structure
568-2583	Turbo Installation

# ELECTRICAL DT CONNECTORS

These connector kits are for replacing individual connectors for harness repairs and rebuilds. All kits contain one plug or receptacle and quantity 1 of each wedge part number listed.

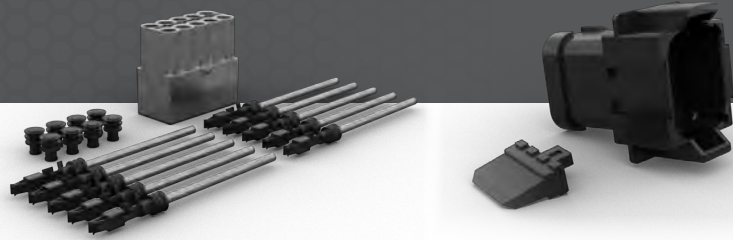

NUMBER	PIN	PLUG	RECEPTACLE	WEDGE
102-8801	12	—	3E-5179	3E-5180
102-8802	2	—	3E-3364	3E-3365
102-8803	3	—	3E-3370	3E-3371
102-8804	4	—	3E-3376	3E-3377
102-8805	6	—	3E-3382	3E-3383
102-8806	8	—	3E-3388	3E-3389
103-8133	12	—	3E-7990	3E-5180
103-8134	12	—	3E-8969	3E-5180
151-9275	6	—	151-9276	3E-3383
155-2255	12	155-2252	—	155-2258
155-2256	12	155-2253	—	155-2258
155-2257	12	155-2254	—	155-2258
155-2260	3	169-8670	—	155-2276, 155-2266
155-2265	8	155-2264	—	155-2259
155-2270	2	155-2269	—	155-2261
155-2271	4	155-2272	—	155-2262
155-2274	6	155-2273	—	155-2263
160-3518	8	—	162-3046	3E-3389
174-0503	3	174-0502	—	155-2276, 155-2266
176-2947	4	176-2946	—	155-2262
177-9653	4	—	177-9649	177-9650
177-9656	4	177-9654	—	177-9655
190-7614	12	—	190-7612	3E-5180
190-7615	12	—	190-7613	3E-5180
237-0165	8	237-0163	—	155-2259
245-7434	10	202-5397, 223-4778	—	288-7146
331-4222	12	331-3578	—	155-2258
331-4226	2	331-3582	—	155-2261
331-4229	3	331-3585	—	155-2266, 155-2276

\*As a good electrical repair & troubleshooting reference, please reference Service Magazine article M0065534, found on sis2.cat.com







# MAINTENANCE

Proactive preventative maintenance extends the life of your machine and protects your investment. Only Caterpillar knows Cat equipment's filtration and lubrication requirements and offers parts kits to match your machine's maintenance cycles.



## CAT® GREASES

Our greases are designed to get long life, world class moisture resistance, low component wear and great corrosion protection for your application.

	LITHIUM COMPLEX			CALCIUM SULFONATE COMPLEX		
Previous Cat Product Name	Cat Multipurpose	Cat Advanced 3 Moly	Cat Arctic Platinum	Cat Ultra5 Moly #1	Cat Ultra5 Moly #2	Cat Desert Gold
Current Cat Product Name	Cat Utility Grease	Cat Prime Application Grease	Cat Extreme Application Grease-Arctic	Cat Extreme Application Grease 1	Cat Extreme Application Grease 2	Cat Extreme Application Grease-Desert
Grade (NLGI)	2	2	0	1	2	2
Machine Operating Temp (deg C)	-20 to +140	-20 to +140	-50 to +130	-20 to +140	-15 to +140	10 to +140
Cartridge** 450g, 15.9oz.**	452-6015	452-6010		452-6000	452-6005	452-7458
Cartridge 390g, 14oz.	452-6011	452-6006	508-2184	452-5996	452-6001	452-6016
Plastic Pail 16kg, 35lb.	452-6014	452-6009	508-2187	452-5999	452-6004	452-6019
Keg 55kg, 120lb.	452-6013	452-6008	508-2186	452-5998	452-6003	452-6018
Drum 180kg, 400lb.	452-6012	452-6007	508-2185	452-5997	452-6002	452-6017
						

\*\* Only available in Australia and New Zealand

## COOLANTS

Up to 12,000-hour (or 6-year) drain interval with an addition of Cat Extender at 6,000 hours and yearly S•O•S<sup>SM</sup> coolant sampling analysis.

CAT ELC (Contains Glycol) Premix lowers maintenance cost and ensures extended life coolant.

1 GALLON	5 GALLON	55 GALLON	75 GALLON	5 LITRE	18 LITRE	20 LITRE	200 LITRE	210 LITRE	1000 LITRE
238-8648	238-8649	238-8650	361-1024	205-6611	365-8396	205-6612	215-4242	205-6613	205-6614
				205-6615		215-4246	365-8397		365-8398
				469-2717		469-2718		469-2719	

CAT ELI (water based, no glycol) Premix lowers maintenance costs and ensures extended life coolant.

1 GALLON	55 GALLON	1 LITRE	5 LITRE	20 LITRE	208 LITRE	1000 LITRE
351-9431	351-9433	469-2722	469-2720	351-9432	387-2878	366-2753
				387-2877		
				469-2721		

Note: To see all Coolants by Region and Coolant recommendations, search PELJ2052 and SEBU6250 or SEBU6251.

# BUCKETS & GROUND ENGAGING TOOLS



# BUCKETS »

Cat® buckets are more than accessories, they are designed as extensions of your machine. Bucket materials, design and fabrication are specially made for the demanding underground environmental and abrasive materials to be moved.

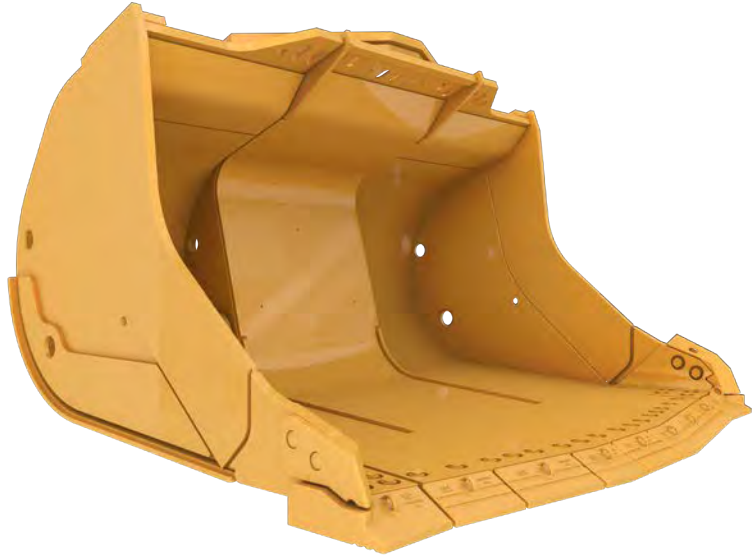

## R1700 – TRADITIONAL BUCKETS

NUMBER	CAPACITY
467-1827	5.7m3 / 7.5Yds3
566-6471	5.8m3 / 7.6Yds3 (Ejector Bucket)
467-1828	6.1m3 / 8.0Yds3
467-1829	6.6m3 / 8.6Yds3
616-0585	7.2m3 / 9.4Yds3
467-1830	7.5m3 / 9.8Yds3
549-5378	8.0m3 / 10.5Yds3
467-1831	8.6m3 / 11.2Yds3 (Light Material Bucket)

## R1700 – BOLT TOGETHER BUCKETS

NUMBER	CAPACITY
561-1775	6.8m3 / 8.9Yds3
581-6671	7.5m3 / 9.8Yds3

## R1700 – DURILOCK RETENTION

NUMBER	NAME
597-6298	Durilock Retention Kit

Note: Please refer to BTB brochure (AEXQ3466) and GET Documentation (PEBJ0030 & PEBJ0031) for further information on GET and bucket offerings.

<https://pricelist.cat.com/priceList/machine/byModel>

<https://expert.cat.com/>

<https://catdealer.com/> - Presentation - Bolt Together Buckets for LHD's

# DURILOCK™ LIP SHROUD SYSTEM »

## MAINTENANCE FREE RETENTION

The new Durilock Lip Shroud system for underground loader buckets is a flexible, productive option for all Cat underground LHDs. This new system features hammerless installation and maintenance-free retention of GET. Three interchangeable shroud styles allow you to configure your loader to its current application needs — without stopping to change the base edge or retention system.

### DURILOCK - TRADITIONAL

---

### D50S

Durilock  
D50S



- Balanced wear design for most applications.
- Baseline design provides equal distribution of Wear Material for applications that do not involve heavy floor cleaning.

### DURILOCK – HEAVY ABRASION

---

### D50A

Durilock  
D50A



- Long Life while maintaining a sharp penetrating profile.
- More usable wear material through the contoured design which repositions material on shroud base.
- Serrated edge design increases material penetration and bucket fill factors.

### DURILOCK - PENETRATION

---

### D50P

Durilock  
D50P



- Penetration of a tip, protection of a lip shroud.
- Serrated edge design increases material penetration and bucket fill factors.

# BOLT ON HALF-ARROW GET »

## EXTENDED SERVICE LIFE THROUGH INTEGRATED DESIGN

The bolt on half arrow (BOHA) system delivers world class lip protection with fewer parts than competitive systems. This means reduced maintenance cost through better protection, and fewer parts to manage. BOHA segments have superior hardness vs. welded components.

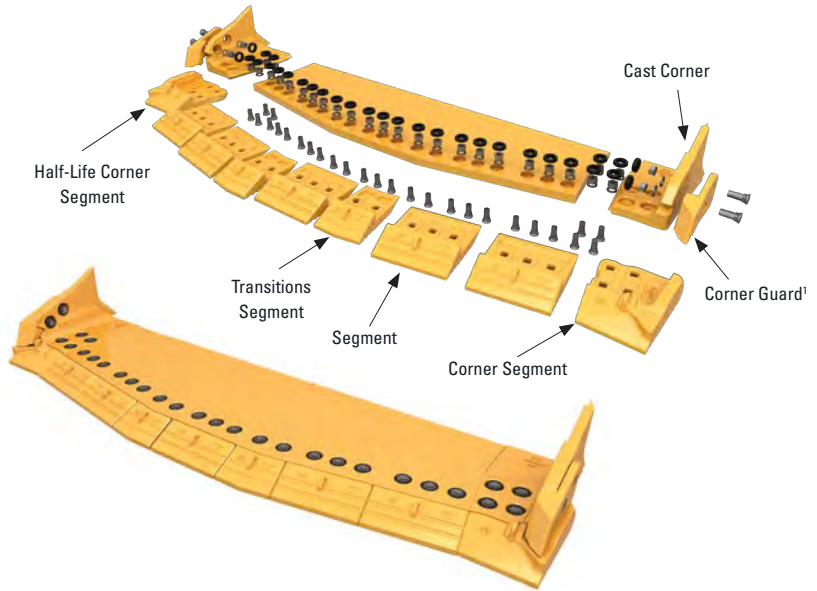

# MODULAR SEGMENT SYSTEM »

## EASIEST INSTALLATION OF ANY WELDED SYSTEM

Modular Shrouds deliver welded part reliability with the replacement simplicity of a mechanical system. Wear indicators are visible from the topside to help establish maintenance intervals. Integrated Bevel allows for faster weld installation time and creates a stronger edge assembly by locking segments together.

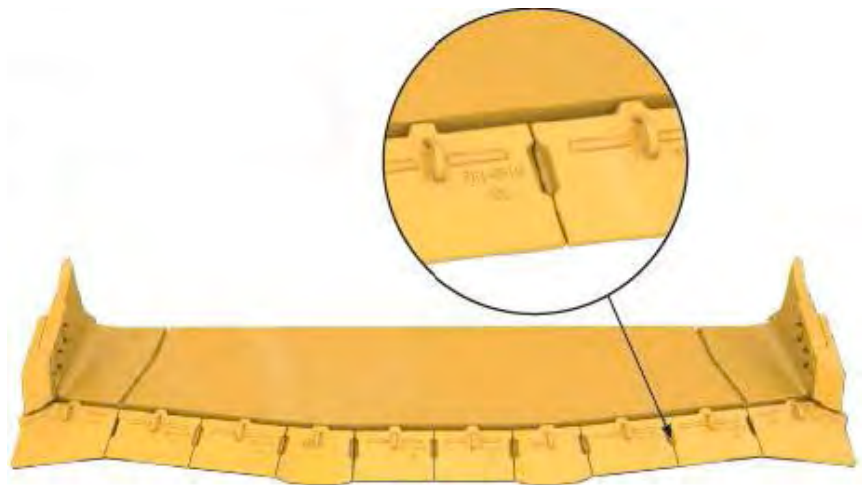

## THANK YOU FOR CHOOSING A CAT® Underground Loader

Cat® underground loaders make your material handling and loading jobs safer, faster, more precise and profitable. Cat underground loaders set the standard for reliability, productivity, fuel efficiency, versatility and operator comfort.

### UPGRADE/REPAIR & REBUILD KITS

Customize your Cat Underground Loader to fit your needs with a variety of specialized products designed for your industry and application. These features, accessories and attachments help optimize and maintain your machine, so you can get the most out of every use. Please reference Service Information System (SIS) for the most up to date information.

### COMMON MAINTENANCE PARTS

Preventative maintenance helps extend the life of your machine and protect your investment. Only Cat Parts are made to match your machine's specific filtration needs, lubrication requirements and exact maintenance cycles. That's why our parts kits make it easier to maintain your machine and keep it running at peak performance.

## LET'S DO THE WORK.™

PEBJ0231-02

January 2025

© 2025 Caterpillar. All Rights Reserved. CAT, CATERPILLAR, LET'S DO THE WORK, their respective logos, "Caterpillar Corporate Yellow", the "Power Edge" and Cat "Modern Hex" trade dress as well as corporate and product identity used herein, are trademarks of Caterpillar and may not be used without permission. VisionLink is a trademark of Caterpillar Inc., registered in the United States and in other Countries.

