

# WHEEL SAWS

SKID STEER LOADERS  
COMPACT TRACK LOADERS  
COMPACT WHEEL LOADERS



Model	Machine Compatibility
SW345	239D3, 246D3, 249D3, 255, 259D3, 260, 262D3, 265, 270, 272D3, 275, 279D3, 285, 289D3, 299D3, 908
SW360	262D3, 260, 265, 270, 272D3, 275, 279D3, 285, 289D3, 299D3
SW380	265, 270, 272D3, 275, 279D3, 285, 289D3, 299D3
SW460	270 XE, 272D3 XHP, 275 XE, 285 XE, 299D3 XHP
SW480	270 XE, 272D3 XHP, 275 XE, 285 XE, 299D3 XHP

Machine model availability and attachment vary by region. Contact your local Cat® dealer for exact compatibility and availability.



Cat® Wheel Saws are designed for high performance trench cutting on a variety of hard or compact surfaces such as asphalt, reinforced concrete, and rocky or frozen ground. They allow for cutting and trenching to be performed in a single pass. Wheel saws are ideal for asphalt patch cutting, road expansion joint cuts, and utility trenching.

## FEATURES

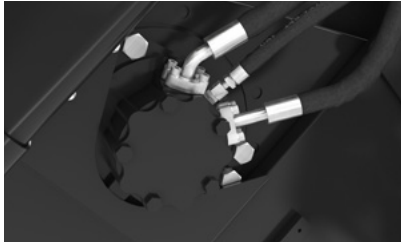

### DIRECT DRIVE SYSTEM

Direct drive system features a hydraulic piston pump motor to ensure maximum cutting rate and wheel torque for optimal production, performance and efficiency.

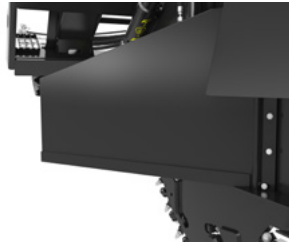

### DEFLECTOR PLATES

Deflector plates remove spoil from machine's path for smooth operation. Spoil can be discharged left, right, or on both sides of the saw with installation of included blanking plates.



### HYDRAULIC DEPTH CONTROL

Hydraulic depth control is controlled from the cab, allowing the operator to adjust cut depth to quickly adjust to the current job as needed. Standard on all models.

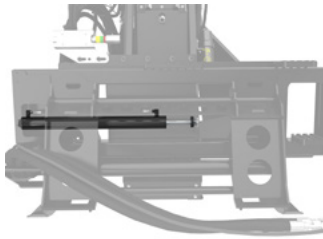

### HYDRAULIC SIDE SHIFT

Hydraulic side shift allows wheel positioning from center to far right of center. Controlled from the cab, this allows for cutting close to curbs, walls and other obstructions, minimizing the need to reposition the machine. Standard on all models.



### SMART CREEP

Smart Creep is a dynamic drive control system that works in conjunction with the initial creep speed setting. Smart Creep senses load on the attachment being operated, and automatically adjusts drive command to keep the attachment running at the most productive speed.

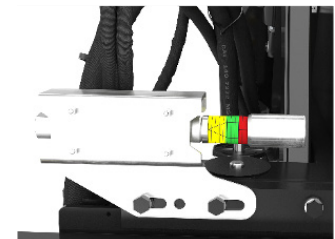

### MAX PRO PRESSURE GAUGE

Max pro pressure gauge provides operator feedback to adjust speed for maximum productivity in changing material loads. Gauge displays wheel saw performance in real-time conditions and is visible from the cab. Standard on all models.



### SELF STANDING

Self standing frame design improves wheel saw stability and safety during machine coupling, parking and storage.



### REVERSE CUTTING

The SW380 and SW480 are reverse cutting wheel saws only and are to be operated in a reversing direction.



### INCLUDED TOOLS

Attachment mounted tools included to provide quick and easy change out of bits when needed.

# FEATURES *(continued)*

---



## TRENCH CLEANING DEVICE

Trench cleaning device is hydraulically operated from the cab. Blade can be controlled up and down to remove spoil and ensure a clean trench.

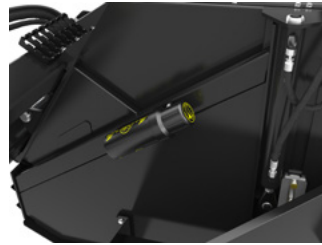

## OMM CONTAINER

Container stores the OMM (Operation and Maintenance Manual) in a protective case on the attachment, where it can be conveniently accessed.

# OPTIONS

---



## WATER KIT READY

Ports are strategically located to equip the saw with a water sprinkler kit along hood, which allows for significant reduction in dust. Machine mounted water tank is required for water sprinkler kit.



## OPTIONAL GUIDE BAR

Optional guide bar allows operator to position wheel saw for a straight cut and aids in visibility.



## BIT OPTIONS

Concrete bits are standard on all models. Optional all purpose conical bits are available for all tarmac and asphalt applications. Heavy duty bits are available for extreme duty applications.



## STANDARD TWO-YEAR WARRANTY

All wheel saws come standard with a two-year warranty to give you peace of mind when purchasing a quality Cat Wheel Saw attachment.

# SPECIFICATIONS

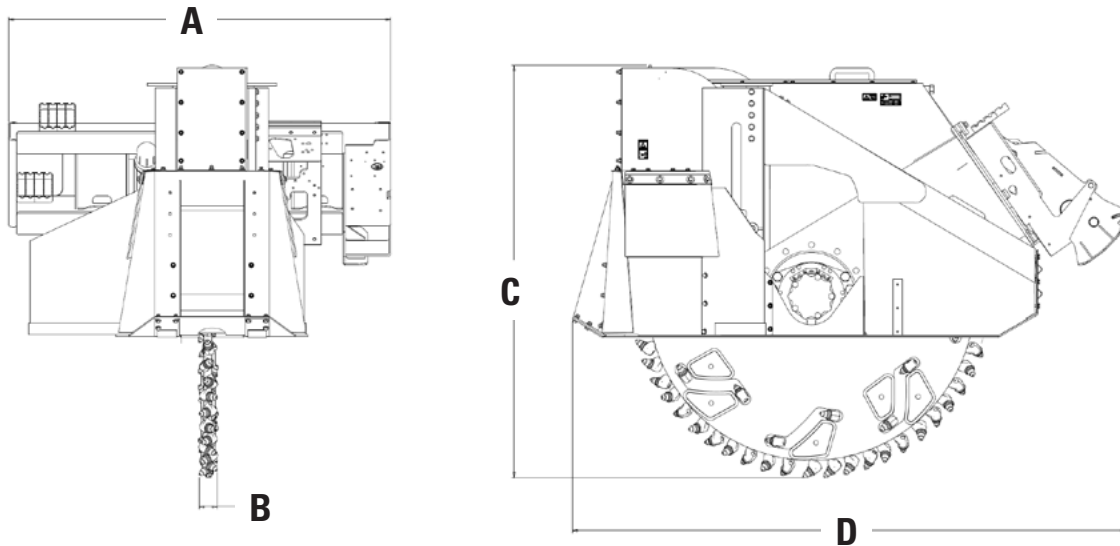

Wheel Saws			
Model	SW345	SW360	SW380
<b>A</b> Overall Width – mm (in)	1655 (65)	1655 (65)	1655 (65)
<b>B</b> Wheel Width – mm (in)	80 (3), 130 (5)	80 (3), 100 (4), 130 (5), 160 (6), 200 (8)	250 (10)
<b>C</b> Overall Height – mm (in)	1455 (57)	1765 (69)	1860 (73)
<b>D</b> Overall Length – mm (in)	2165 (85)	2417 (95)	2600 (102)
Weight – kg (lb)			
80 mm (3 in)	1126 (2,482)	1440 (3,175)	–
100 mm (4 in)	–	1335 (2,943)	–
130 mm (5 in)	1016 (2,240)	1365 (3,009)	–
160 mm (6 in)	–	1315 (2,899)	–
200 mm (8 in)	–	1325 (2,921)	–
250 mm (10 in)	–	–	1450 (3,197)
Maximum Cutting Depth – mm (in)	450 (18)	600 (24)	800 (32)
Required Hydraulics	XPS	XPS	XPS
Optimal Hydraulic Flow – L/min (gpm)	98-125 (26-33)	98-125 (26-33)	98-125 (26-33)
Optimal Hydraulic Pressure – bar (psi)	230-280 (3,300-4,000)	230-280 (3,300-4,000)	230-280 (3,300-4,000)
Wheel Torque at Max Pressure – N-m (ft-lb)	6244 (4,605.3)	7509 (5,538.3)	7509 (5,538.3)
Wheel Speed at Maximum Flow – rpm	89	74	74
Bit Speed at Maximum Flow – m/min (ft/min)	349 (1,143)	360 (1,180)	372 (1,228)
Side Shift Travel – mm (in)	550 (21.7)	550 (21.7)	550 (21.7)
Motor Displacement – cm <sup>3</sup> /rev (in <sup>3</sup> /rev)	1404 (85.7)	1686 (102.9)	1686 (102.9)
Conical Bits per Wheel			
80 mm (3 in)	64	70	–
100 mm (4 in)	–	80	–
130 mm (5 in)	64	80	–
160 mm (6 in)	–	96	–
200 mm (8 in)	–	96	–
250 mm (10 in)	–	–	72
Trench Cleaning Device			
80 mm (3 in)	No	No	–
100 mm (4 in)	–	Yes	–
130 mm (5 in)	Yes	Yes	–
160 mm (6 in)	–	Yes	–
200 mm (8 in)	–	Yes	–
250 mm (10 in)	–	–	No
Interface	Skid Steer Loader	Skid Steer Loader	Skid Steer Loader

# SPECIFICATIONS

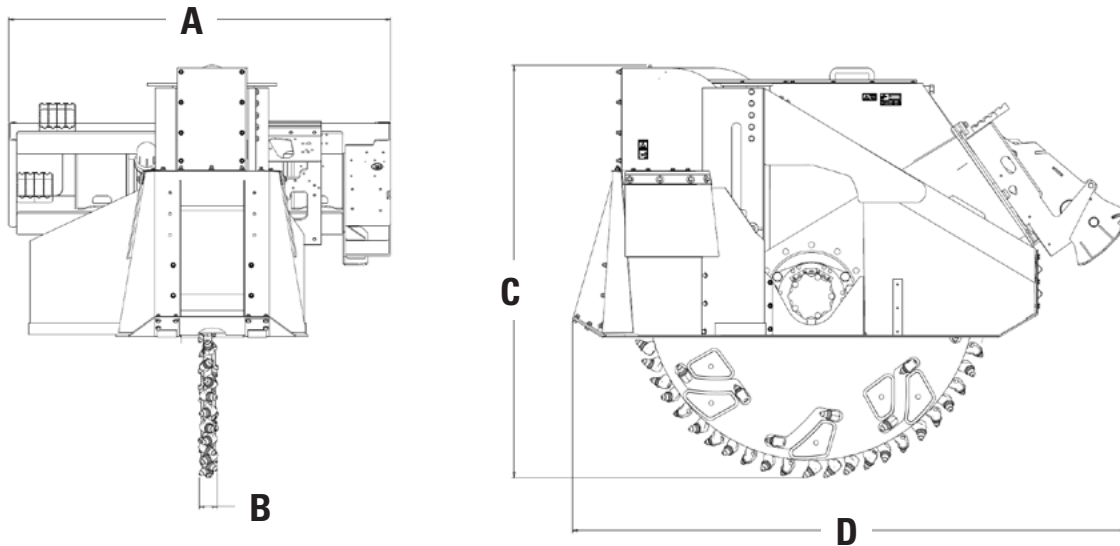

Wheel Saws		
Model	SW460	SW480
<b>A</b> Overall Width – mm (in)	1655 (65)	1655 (65)
<b>B</b> Wheel Width – mm (in)	80 (3), 160 (6), 200 (8)	250 (10)
<b>C</b> Overall Height – mm (in)	1765 (69)	1860 (73)
<b>D</b> Overall Length – mm (in)	2417 (95)	2600 (102)
Weight – kg (lb)		
80 mm (3 in)	1440 (3,175)	–
100 mm (4 in)	–	–
130 mm (5 in)	–	–
160 mm (6 in)	1315 (2,899)	–
200 mm (8 in)	1325 (2,921)	–
250 mm (10 in)	–	1450 (3,197)
Maximum Cutting Depth – mm (in)	600 (24)	800 (32)
Required Hydraulics	XHP/XE	XHP/XE
Optimal Hydraulic Flow – L/min (gpm)	136-150 (36-40)	136-150 (36-40)
Optimal Hydraulic Pressure – bar (psi)	250-280 (3,630-4,000)	250-280 (3,630-4,000)
Wheel Torque at Max Pressure – N-m (ft-lb)	7509 (5,538.3)	7509 (5,538.3)
Wheel Speed at Maximum Flow – rpm	89	89
Bit Speed at Maximum Flow – m/min (ft/min)	430 (1,420)	444 (1,466)
Side Shift Travel – mm (in)	550 (21.7)	550 (21.7)
Motor Displacement – cm <sup>3</sup> /rev (in <sup>3</sup> /rev)	1686 (102.9)	1686 (102.9)
Conical Bits per Wheel		
80 mm (3 in)	70	–
100 mm (4 in)	–	–
130 mm (5 in)	–	–
160 mm (6 in)	96	–
200 mm (8 in)	96	–
250 mm (10 in)	–	72
Trench Cleaning Device		
80 mm (3 in)	No	–
100 mm (4 in)	–	–
130 mm (5 in)	–	–
160 mm (6 in)	Yes	–
200 mm (8 in)	Yes	–
250 mm (10 in)	–	No
Interface	Skid Steer Loader	Skid Steer Loader

For more complete information on Cat products, dealer services and industry solutions, visit us on the web at [www.cat.com](http://www.cat.com)

AEHQ8516 (01-2025)  
(Global)

© 2025 Caterpillar. All Rights Reserved.

Materials and specifications are subject to change without notice. Featured machines in photos may include additional equipment. See your Cat dealer for available options.

CAT, CATERPILLAR, LET'S DO THE WORK, their respective logos, "Caterpillar Corporate Yellow," the "Power Edge" and Cat "Modern Hex" trade dress as well as corporate and product identity used herein, are trademarks of Caterpillar and may not be used without permission.

[www.cat.com](http://www.cat.com) [www.caterpillar.com](http://www.caterpillar.com)

