



D10

Dozer

Technical Specifications

Configurations and features may vary by region. Please consult your Cat® dealer for availability in your area.

Table of Contents

Specifications	2
Engine – U.S. EPA Tier 2 Equivalent	2
Engine – U.S. EPA Tier 4 Final/EU Stage V	2
Hydraulic Controls	2
Weights	2
Air Conditioning System	2
Fluid Capacities	3
Transmission	3
Drawbar Pull vs. Track Speed	3
Rollover Protective Structure (ROPS)/ Falling Object Protective Structure (FOPS)	3
Sound	3
Undercarriage	3
Steering and Brakes	3
Dimensions	4
Blade Specifications	5
Track Links and Shoes	6
Ripper	6
Standard and Optional Equipment	7

D10 Dozer Specifications

Engine – U.S. EPA Tier 2 Equivalent

Engine Model	Cat® C27	
Bore	137 mm	5.4 in
Stroke	152 mm	6.0 in
Displacement	27.0 L	1,648 in ³
Engine Power		
Gross SAE J1995*		
Forward	471 kW	631 hp
Reverse	571 kW	766 hp
ISO 14396*		
Forward	464 kW	622 hp
Reverse	564 kW	756 hp
Net SAE J1349/ISO 9249**		
Forward	450 kW	603 hp
Reverse	538 kW	722 hp
Emissions	U.S. EPA Tier 2 Equivalent	

*Excludes all fan losses

• All Engine ratings apply at 1,800 rpm.

• Tier 2 equivalent rating (in FWD gears) begins altitude de-rate at 4480 m (14,700 ft).

• Tier 4 Final/EU Stage V equivalent rating (in FWD gears) begins altitude de-rate at 4420 m (14,500 ft).

**Net power advertised is the power available at the flywheel when the engine is equipped with air cleaner, muffler, alternator, fan, and engine emissions controls as required at 25° C ambient temperature.

Engine – U.S. EPA Tier 4 Final/EU Stage V

Engine Model	Cat C27	
Bore	137 mm	5.4 in
Stroke	152 mm	6.0 in
Displacement	27.0 L	1,648 in ³
Engine Power		
Gross SAE J1995*		
Forward	471 kW	631 hp
Reverse	597 kW	801 hp
ISO 14396*		
Forward	462 kW	620 hp
Reverse	588 kW	789 hp
Net SAE J1349/ISO 9249**		
Forward	449 kW	602 hp
Reverse	564 kW	756 hp
Emissions	U.S. EPA Tier 4 Final/ EU Stage V	

Hydraulic Controls

Pump Type	Variable displacement piston pump	
Implement Pump Output	424 L/min	112.0 gal/min
Fan Pump	82 L/min	21.7 gal/min
Tilt Cylinder Rod End Flow	424 L/min	112.0 gal/min
Tilt Cylinder Head End Flow	240 L/min	63.4 gal/min
Lift Cylinder Relief Valve Setting	28 000 kPa	4,061.1 psi
Tilt Cylinder Relief Valve Setting	26 700 kPa	3,872.5 psi
Ripper (Lift) Relief Valve Setting	28 000 kPa	4,061.1 psi
Ripper (Pitch) Relief Valve Setting	28 000 kPa	4,061.1 psi
Tank Capacity	122 L	32.2 gal
Cylinder Sizing	Bore	
Blade Lift	140 mm	5.5 in
Blade Tilt	210 mm	8.3 in
Ripper Shank Lift	209.6 mm	8.3 in
Ripper Shank Angle	180 mm	7.1 in
Cylinder Sizing	Stroke	
Blade Lift	1653 mm	65.1 in
Blade Tilt	241 mm	9.5 in
Ripper Shank Lift	535 mm	21.1 in
Ripper Shank Angle	660 mm	26.0 in

• Implement Pump output measured are 2,010 engine rpm and 7000 kPa (1,015 psi).

• Electro-hydraulic pilot valves assist operations of ripper and dozer controls.

• Fan Pump output measured at 2,010 engine rpm and 26 000 kPa (3,771 psi).

Weights

Operating Weight	70 256 kg	154,888 lb
Shipping Weight	50 684 kg	111,739 lb

• D10 Operating Weight includes coolant, lubricants, full fuel tank, Rollover Protective Structure (ROPS), Falling Object Protective Structure (FOPS) cab, SU ABR bulldozer, dual tilt, single-shank ripper with pin-puller, fast fuel, 610 mm (24 in) ES shoes, and operator.

• D10 Shipping Weight includes coolant, lubricants, 10% fuel, FOPS cab, fast fuel, and 610 mm (24 in) ES shoes.

Air Conditioning System

The air conditioning system on this machine contains the fluorinated greenhouse gas refrigerant R134a (Global Warming Potential = 1430). The system contains 1.8 kg of refrigerant which has a CO₂ equivalent of 2.600 metric tonnes.

Fluid Capacities

Fuel Tank – Total Volume	1269 L	335.2 gal
Fuel Tank – Usable Volume	1224 L	323.3 gal
Cooling System Refill – Tier 4 Final Engine	175 L	46.2 gal
Engine Crankcase Sump	103 L	27.2 gal
Power Train – Total Volume	308 L	81.4 gal
Power Train – Refill Volume	283 L	74.8 gal
Final Drives (each)	23 L	6.1 gal
Track Roller Frames (each)	64 L	16.9 gal
Pivot Shaft Oil	36 L	9.5 gal
Hydraulic System Tank Only	160 L	42.2 gal

Transmission

1.0 Forward	4 km/h	2.5 mph
1.5 Forward	5.4 km/h	3.4 mph
2.0 Forward	7.2 km/h	4.5 mph
2.5 Forward	9.6 km/h	6.0 mph
3.0 Forward	12.5 km/h	7.8 mph
1.0 Reverse	5.2 km/h	3.2 mph
1.5 Reverse	6.7 km/h	4.2 mph
2.0 Reverse	9 km/h	5.6 mph
2.5 Reverse	12.1 km/h	7.5 mph
3.0 Reverse	15.7 km/h	9.8 mph
Type	Planetary powershift	
Transmission Clutch Diameter	431.8 mm	17"

Drawbar Pull vs. Track Speed

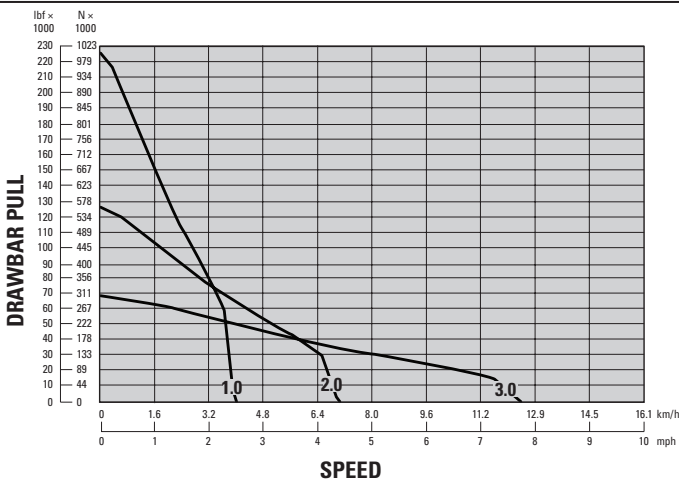

ROPS/FOPS

- ROPS meets the following criteria: ISO 3471:2008.
- FOPS meets the following criteria: ISO 3449:2005 LEVEL II.

Sound

Sound Level	Test Method
Operator Sound Pressure Level	78 db(A) ISO 6396:2008 ¹
Exterior Sound Pressure Level	116 db(A) ISO 6395:2008 ²

¹The measurement was conducted at 70% of the maximum engine cooling fan speed. The sound level may vary at different engine cooling fan speeds. The measurement was conducted with the cab doors and the cab windows closed. The cab was properly installed and maintained.

²The measurement was conducted at 70% of the maximum engine cooling fan speed. The sound level may vary at different engine cooling fan speeds.

- The sound levels listed above include both measurement uncertainty and uncertainty due to production variation.
- The available sound suppression package can reduce the dynamic exterior sound power level of the machine by up to 4 db(A) and the dynamic operator sound pressure level by up to 2 db(A).

Undercarriage

Shoe Type	Extreme Service (ES)	
Width of Shoe	610 mm	24.0 in
Shoes/Side	44	
Grouser Height	93 mm	3.7 in
Pitch	260 mm	10.2 in
Ground Clearance	725 mm	28.5 in
Track Gauge	2550 mm	100.4 in
Length of Track on Ground	3880 mm	152.8 in
Ground Contact Area	4.74 m ²	7,347 in ²
Track Rollers/Side	8	
Number of Carrier Rollers	1 per side (optional)	

Steering and Brakes

Steering Type	Hydraulically Applied Multiple-Disc Steering Clutch	
Brake Type	Spring Applied Multiple-Disc Brake	
Brake Diameter	392 mm	15.4 in
Brake Count	10	

D10 Dozer Specifications

Dimensions

All dimensions are approximate.

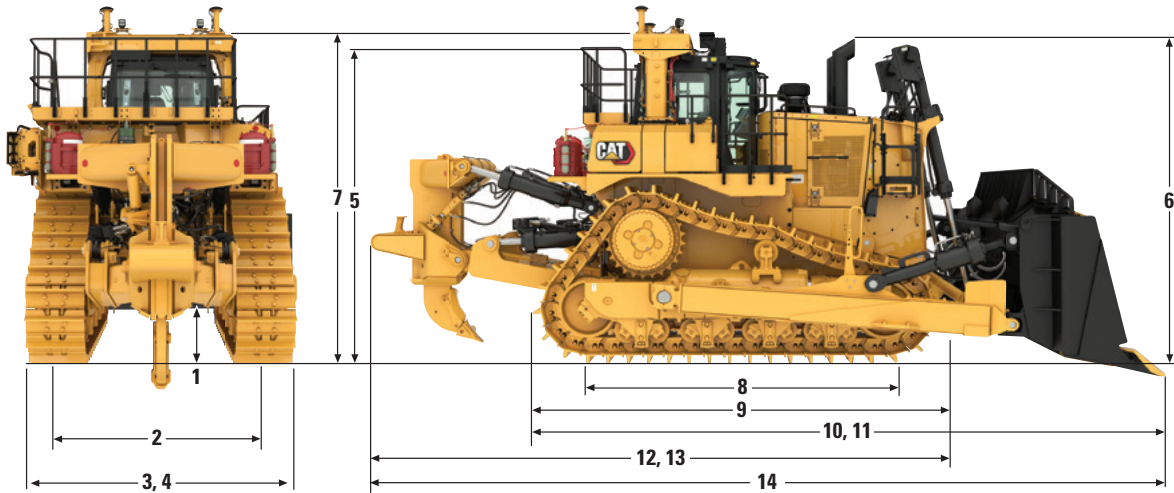

	D10	
1 Ground Clearance*	725 mm	28.5 in
2 Track Gauge	2550 mm	100.4 in
3 Width without Trunnions (610 mm/24 in ES)	3311 mm	130.4 in
4 Width over Trunnions	3759 mm	148.0 in
5 Height (FOPS Cab)*	4134 mm	162.8 in
6 Height (Top of Stack)*	4356 mm	171.5 in
7 Height (ROPS/Canopy)*	4406 mm	173.5 in
8 Length of Track on Ground	3880 mm	152.8 in
9 Overall Length, Basic Dozer	5324 mm	209.6 in
10 Length with SU-Blade	7416 mm	292.0 in
11 Length with U-Blade	7750 mm	305.1 in
12 Length with Single-Shank Ripper	7081 mm	278.8 in
13 Length with Multi-Shank Ripper	7241 mm	285.1 in
14 Overall Length, SU-Blade and SS Ripper	9158 mm	360.6 in

*Includes grouser height for total dimensions on hard surfaces.

Blade Specifications

Blade		10SU ABR	10U ABR
Blade Capacity (SAE J1265)	m ³	18.5	22
	yd ³	24.2	28.7
Blade Width (over end bits)	mm	4940	5260
	in	194.5	207.1
Blade Height	mm	2120	2120
	in	83.5	83.5
Digging Depth			
Blade Pitch – Full Racked Back (Carry)	mm	507.47	507.47
	in	19.98	19.98
Blade Pitch – Nominal	mm	640.87	640.87
	in	25.23	25.23
Blade Pitch – Full Pitched Forward (Spread)	mm	764.12	764.12
	in	30.08	30.08
Ground Clearance			
Blade Pitch – Full Racked Back (Carry)	mm	1680	1680
	in	66.1	66.1
Blade Pitch – Nominal	mm	1523	1523
	in	60	60
Blade Pitch – Full Pitched Forward (Spread)	mm	1368	1368
	in	53.9	53.9
Maximum Tilt LH	mm	1430	1545
	in	56.3	60.8
	Degrees	17.31	17.31
Maximum Tilt RH	mm	1430	1545
	in	56.3	60.8
	Degrees	17.31	17.31
Cutting Edge Angle			
Blade Pitch – Full Racked Back (Carry)	Degrees	47.20	47.20
Blade Pitch – Nominal	Degrees	53.00	53.00
Blade Pitch – Full Pitched Forward (Spread)	Degrees	59.00	59.05
Weights			
Blade Weight (Moldboard Only)	kg	5790	5790.00
	lb	10,829.11	12,764.76
Blade Weight*	kg	9421.00	10,698.00
	lb	20,769.75	23,585.05
Total Operating Weight** (with blade and single-shank ripper)	kg	70,256	
	lb	154,888	

*Does not include hydraulic controls but includes blade cylinders, pusharms.

**D10 Operating Weight includes coolant, lubricants, full fuel tank, ROPS, FOPS cab, SU ABR bulldozer, dual tilt, single-shank ripper with pin-puller, fast fuel, 610 mm (24 in) ES shoes, and operator.

D10 Dozer Specifications

Track Links and Shoes

Common track link and track shoe offering shown below. Additional arrangements available; some will be offered through parts system only.

	Extreme Service	Super Extreme Service	Round Hole
General Duty			
610 mm (24")	✓		
Heavy Duty			
610 mm (24")	✓		
610 mm (24")	✓		✓
610 mm (24")		✓	
610 mm (24")*	✓		
610 mm (24")*		✓	✓
710 mm (28")	✓		
710 mm (28")	✓		✓
710 mm (28")		✓	
Heavy Duty, Extended Life with DuraLink™ (HDXL)			
610 mm (24")		✓	
610 mm (24")		✓	✓
710 mm (28")		✓	
710 mm (28")		✓	✓
786 mm (31")	✓		
786 mm (31")	✓		✓

*Five tooth master link with fine thread bolts

Ripper

		Single Shank		Multi Shank	
		Standard	Deep	Standard	Deep
Overall beam width	mm (in)	—	—	2920 (115)	2920 (115)
Maximum penetration force (shank vertical)	kN (lbf)	219 (49,233)	236 (53,055)	208 (46,760)	229 (51,481)
Maximum penetration (standard tip)	mm (in)	1504 (59.2)	1988 (78.3)	950 (37.4)	1869 (73.6)
Pryout force (multi-shank ripper with one tooth)	kN (lbf)	512 (115,102)	510 (114,653)	515 (115,777)	513 (115,327)
Maximum clearance raised (under tip, pinned in bottom hole)	mm (in)	912 (36)	703 (27.7)	1055 (41.5)	1055 (41.5)
Number of shank holes		3	3	2	4
Weight (with one shank)	kg (lb)	6445 (14,209)	6599 (14,548)	6132 (13,519)	6330 (13,955)
With 10 SU ABR Blade and Ripper					
Total Operating Weight*	kg (lb)	70 256 (154,888)	70 256 (154,888)	70 256 (154,888)	70 256 (154,888)

*D10 Operating Weight includes coolant, lubricants, full fuel tank, ROPS, FOPS cab, SU ABR bulldozer, dual tilt, single-shank ripper with pin-puller, fast fuel, 610 mm (24 in) ES shoes, and operator.

Note: Add 544 kg (1,199 lb) for each additional shank.

Note: Single-shank, ripping arrangement weight includes pin puller.

Note: Deep shanks perform best in loose material.

D10 Dozer Standard and Optional Equipment

Standard and Optional Equipment

Standard and optional equipment may vary. Consult your Cat dealer for details.

	Standard	Optional		Standard	Optional
OPERATOR ENVIRONMENT			OPERATOR ENVIRONMENT (CONTINUED)		
ROPS/FOPS, Sound-Suppressed Cab	✓		Interior Backlighting – Dimmable	✓	
High-Definition Primary Touchscreen Display	✓		Operator Control – Decelerator Pedal	✓	
High-Definition Vision Display		✓	Operator Control – Blade, Electronic	✓	
MineStar™ Terrain Display		✓	Operator Control – Ripper, Electronic	✓	
Visibility – Rearview Mirrors	✓		Operator Control – Park Brake, Electronic	✓	
Visibility – Single Camera: Back-up		✓	Operator Control – Engine Speed Control Dial	✓	
Visibility – Dual Camera: Back-up and Ripper		✓	Radio Mount, Site Communications	✓	
Visibility – Five Camera: 360 Degree View and Ripper Camera		✓	Cab Filter – Precleaner	✓	
Air Conditioner and Heater with Automatic Climate Control	✓		Cab Filter – Powered Precleaner		✓
Air Conditioning Condenser, Cab Mounted	✓		Cab Filter – HEPA Powered Precleaner		✓
Seat – Cloth with Air Suspension	✓		Active Fluid Level Monitoring with “OK to Start”	✓	
Seat – Heated, Cooled with Adjustable Lumbar and Bolsters		✓	Machine Overspeed Protection	✓	
Seat – Seat Belt, 76 mm (3 in) Retractable with Switch	✓		Slope and Side Slope Monitor	✓	
Seat – Armrest, Adjustable	✓		Sound Arrangement		✓
Window Wipers with Wash – Low, High, Intermittent	✓		CAT TECHNOLOGY PRODUCTS		
Adjustable Fingertip Steering Controls	✓		VIMS™	✓	
Entertainment Radio Ready (12V Power, Harness, Speakers)	✓		Cat Product Link™ Elite (cellular)	✓	
Entertainment Radio – AM/FM, Aux Input and Bluetooth®		✓	Cat Product Link Elite Dual Mode (cellular + satellite)		✓
Cab Glass – Single-Pane Tinted Safety	✓		Automated Blade Assist (ABA)	✓	
Cab Glass – Dual-Pane Laminated Impact Safety		✓	Autocarry™		✓
Cab Glass – High-Pressure Safety (275 kPa/40 psi)		✓	Auto Ripper Control		✓
Cab Glass – Window Sunscreen		✓	Cat Grade with 3D Blade Control		✓
5th Percentile Operator Mounting Group		✓	MineStar™ Terrain Ready		✓
Cab Access – Access/Egress Lighting with Shutdown Timer	✓		MineStar™ Terrain with Blade Control		✓
Cab Access – Blade Push-Arm Steps and Grab Handle	✓		MineStar™ Command Remote Control Ready		✓
Cab Access – Fender Platform Guardrails	✓				
Cab Access – Rear Cab Platform and Guardrails		✓			
Cab Access – Powered Ladder		✓			
Cab Access – Rearward Hinged Cab door	✓				
Cab Access – Forward Hinged Cab door		✓			
Interior LED Courtesy Lights	✓				

(continued on next page)

D10 Dozer Standard and Optional Equipment

Standard and Optional Equipment *(continued)*

Standard and optional equipment may vary. Consult your Cat dealer for details.

	Standard	Optional		Standard	Optional
POWER TRAIN			FLUIDS		
Cat C27 Engine – U.S. EPA Tier 4 Final/ EU Stage V, U.S. EPA Tier 2 Equivalent	✓		Coolant – Extended Life, Standard (–37° C/–25° F)	✓	
Stator Clutch Torque Divider – Electronic Control	✓		Coolant – Extended Life, Arctic (–51° C/–60° F)		✓
Powershift Transmission – Three-Speed Electronic Shift	✓		UNDERCARRIAGE		
Clutch/Brake Steering – Electronic Control	✓		Suspension-Type Undercarriage	✓	
Final Drives – Open Labyrinth	✓		Track Links – Heavy-Duty Positive Pin Retention (PPR)	✓	
Final Drives – Cold Weather		✓	Track Links – Heavy-Duty XL – DuraLink		✓
Final Drives – Guarded		✓	Track Guide	✓	
Enhanced Auto Shift (EAS)	✓		Two-Piece Single-Tooth Master Link	✓	
Auto Engine Idle Shutdown	✓		Two-Piece Five-Tooth Master Link		✓
Controlled Throttle Shifting With Shift Management	✓		Lifetime-Lubricated Rollers and Idlers	✓	
Cooling – Air-to-Air Aftercooler	✓		Hydraulic Track Adjusters	✓	
Cooling – High-Performance Single-Plane Package with Aluminum Radiator	✓		Carrier Roller Ready	✓	
Cooling – High-Performance Single-Plane Package with Copper Grommeted Tube Radiator		✓	Equalizer Bar – Greased End Pin Bearings	✓	
Cooling – Hydraulically Driven Fan	✓		Track Shoe (ES): 610/710/785 mm (24, 28, 31 inch) Width	✓	
Cooling – Hydraulically Driven Fan With Reversing Capability		✓	Track Shoe (SES): 610/710/785 mm (24, 28, 31 inch) Width		✓
Air Filters – Dual with Strata Precleaners, Electronic Service Indicator	✓		Track Shoe (ES, SES): Anti-Packing Round Hole 610/710/785 mm (24, 28, 31 inch) Width		✓
Air Filters – Dual with Turbine Precleaners, Electronic Service Indicator		✓	Abrasion Rollers and Idlers		✓
Stainless Steel Manifold Shields and Thermal Wrapped Turbos	✓		Cold Weather Rollers and Idlers		✓
Starting Aid – Engine Heater Group (120V or 240V)		✓	Sound-Suppression Undercarriage		✓
Starting Aid – Automatic Ether		✓	Carrier Roller		✓
Fuel Tank – 1224 liter (323 U.S. gal)	✓		Carrier Roller – Cold Weather		✓
Fuel Priming Pump – Automatic	✓		HYDRAULICS		
Fuel Water Separator	✓		Electronically Controlled, Load-Sensing Dozer Lift and Tilt	✓	
Fuel Heater		✓	Electronically Controlled, Load-Sensing Ripper Lift and Pitch	✓	
Engine Oil Prelubrication System		✓	Dozer Blade Dual Tilt, Guarded Lines	✓	
			Electronically Enabled Blade, Quick Drop	✓	
			Ripper Pin Puller		✓
			Hydraulic Tank Return Screen	✓	

(continued on next page)

D10 Dozer Standard and Optional Equipment

Standard and Optional Equipment *(continued)*

Standard and optional equipment may vary. Consult your Cat dealer for details.

	Standard	Optional		Standard	Optional
ELECTRICAL			REAR ATTACHMENTS		
24V Electric Start	✓		Ripper – Single Shank with Pin Puller		✓
Alternator – 150-Amp	✓		Ripper – Single Shank with Pin Puller and Retrieval Hitch		✓
Batteries – 2x, 200-Amp Hour 12V	✓		Ripper – Multi Shank (three shank)		✓
Batteries – 4x, 200-Amp Hour 12V		✓	Ripper – Multi Shank Deep with Pin Puller		✓
Converter – 12V, 25-Amp	✓		Counterweight – Rear, 3 Weighted Plates		✓
Battery Isolation – Single Pole	✓		Counterweight – Rear, 4 Weighted Plates		✓
Battery Isolation – Dual Pole		✓	No Rear Attachment for customers who already have a rear attachment		✓
Starter Control Isolation	✓		BLADES		
Starter Power Isolation		✓	Semi-Universal (18.5 m ³ /24.2 yd ³)		✓
Back-up alarm	✓		Universal (22.0 m ³ /28.7 yd ³)		✓
Lights, Engine Compartment	✓		WORKTOOLS BLADES		
Lights – LED – 13 Positions	✓		Reclamation Universal (24.5 m ³ /32.0 yd ³)		✓
Lights – Premium LED – 13 Positions		✓	Coal Universal (46.1 m ³ /60.3 yd ³)		✓
Light – Warning Strobe		✓	Coal Universal (52.0 m ³ /68.0 yd ³)		✓
SERVICE AND MAINTENANCE			Woodchip Universal (72.6 m ³ /95 yd ³)		✓
Ecology Fluid Drains – All Compartments	✓		Cushion Dozer Blade		✓
Radiator Guard – Swing-Out Access Doors	✓		Black Blade Paint		✓
Replaceable Bearings – Pusharm Ripper	✓		Abrasion Liners and Guards		✓
Bottom Guards – Hinged With Release Catch	✓		OTHER		
Bottom Guards – Sealed with sound reduction		✓	Fire Suppression Ready		✓
Bottom Guards – Partial		✓	Fire Suppression Installed		✓
Bottom Guards – Cushion Dozer		✓			
Ground-Level – Fast Fuel Fill	✓				
Ground-Level – Fluid Fill and Drain Engine, Power Train, Hydraulic and Coolant		✓			
Ground-Level – Electrical Service Station	✓				
Scheduled Oil Sampling (S·O·S SM) Fluid Sampling Ports	✓				
Diagnostic Connector	✓				
Quick-Opening Cab Mounting Group		✓			
Ripper Lubrication – Grouped		✓			
Ripper Lubrication – Autolube with Ground-Level Fill		✓			
CapSure™ Hammerless Ripper Tip and Shank Protectors	✓				
Anchorage Points	✓				

For more complete information on Cat products, dealer services, and industry solutions, visit us on the web at www.cat.com

© 2025 Caterpillar
All rights reserved

Materials and specifications are subject to change without notice. Featured machines in photos may include additional equipment. See your Cat dealer for available options.

CAT, CATERPILLAR, LET'S DO THE WORK, their respective logos, "Caterpillar Corporate Yellow," the "Power Edge" and Cat "Modern Hex" trade dress as well as corporate and product identity used herein, are trademarks of Caterpillar and may not be used without permission.

AEXQ3209-02 (02-2025)
Replaces AEXQ3209-01
Build Number: 07A
(Global)

