

PM820 | PM822 | PM825

COLD PLANERS



U.S. EPA Tier 4 Final and EU Stage V

Gross Power (SAE J1995:2014)

601 kW (806 hp)

Engine Power (ISO 14396:2002)

595 kW (798 hp)

Milling Width

PM820

2010 mm (79.1 in)

PM822

2235 mm (88.0 in)

PM825

2505 mm (98.6 in)

See Technical Specifications for detailed engine emissions information.



PM820, PM822 & PM825

COLD PLANERS

The powerful **PM820, PM822 AND PM825** are equipped to deliver efficient performance and high production with the milling precision you need to stay competitive. With three milling widths and options available for enhanced versatility, you can customize your machine to suit numerous applications. Whether texturing a road or milling an airport runway, a configuration is available to help you meet your job requirements.



EFFICIENT PERFORMANCE

Integrated machine systems, traction control and a System K rotor combined with the power of the Cat® C18 twin-turbo engine help maximize productivity and efficiency.

EASY OPERATION

Controls, touchscreen displays and the Grade and Slope system are designed to be simple and intuitive. Four, 18-function, ground-level keypads give operators access to numerous machine functions.

ADVANCED DESIGN

Exclusive machine features combined with proven Cat systems help crews operate more effectively.

LATEST UPDATES



Not all features are available in all regions. Please check with your local Cat dealer for specific offering availability in your area. Build Number: 02C

OPERATOR COMFORT

- + Sideways and rotational operator console adjustments (option)
- + Center console displays telescope to bring touchscreens within reach and fold down for secure and convenient storage
- + Cushioned arm and hip rests
- + Anti-fatigue floor mats
- + Convenient platform access with continuous handrails and easy-open gates
- + Flush-mounted front ground controls help enhance operator sight lines to the front tracks
- + Seating and storage options

OPERATION

- + Redesigned anti-slab plow for improved operation and reduced wear*
- + Improved anti-slab-to-conveyor sealing designed to contain more material*
- + Ground control displays have a robust mounting system and quickly detach for storage without disconnecting harnesses
- + High-visibility LED water level lightbars (included in enhanced lighting package)
- + Large water spray manifold handles for easy control

EQUIPMENT MANAGEMENT

- + Remote Flash allows software updates to be conveniently provided on your schedule
- + Remote Troubleshoot diagnostic testing helps reduce service time

* PM820, PM822 and PM825 Build Number 02C compared to PM820, PM822 and PM825 Build Number 02B.

MADE TO GET THE WORK DONE

A fuel-efficient engine and effective conveyor system are designed to provide the power and performance needed to keep up with the demands of grinding through pavement hour after hour.

FUEL-EFFICIENT POWER

The Cat C18 twin-turbo engine is sized to help balance fuel burn and power to meet production goals.

Engine Idle Speed Management helps maximize fuel efficiency by elevating engine speed to an intermediate idle to complete specific tasks and returning to low idle when finished. A variable-speed cooling fan operates at the lowest possible speed for optimal cooling.

Features like Automatic Load Control and multiple rotor speed selections aid in maximizing production at lower engine speeds for fuel-efficient milling.

EFFICIENT MATERIAL REMOVAL

High-capacity conveyors with a wide opening and seamless belt efficiently remove milled material. Belt speed can be adjusted to match material type and production rate and the built in "boost" feature provides a temporary surge in belt speed to eject material faster and farther. The belt reverses for fast cleanout and the loading conveyor folds hydraulically for easy maintenance and transportation. Easy-to-open side covers provide quick access to inspect and clean the rollers.





OPTIMAL

TRACTION AND MANEUVERABILITY

TRACKS INSPIRED FROM A LEGACY

The reliable track undercarriage system on PM800-Series cold planers leverages proven designs from Cat dozers. A well-engineered track geometry is designed to provide high tractive effort and better load distribution when milling deep cuts or through hard materials.

ADVANCED PROPEL SYSTEM

A robust dual pump propel system with Automatic Traction Control drives the tracks in a cross-drive pattern to maintain consistent production in almost any application. Automatic Load Control monitors demand on the machine and adjusts milling speeds to help prevent overloading while maintaining production rates.

DESIGNED FOR MOBILITY

Four steering modes with an automatically-adjusting alignment system are designed to deliver maximum steering precision and smooth turning, further enhanced by the large ground contact area of each track.

CONSISTENT MILLING PATTERNS

MADE EASY

Automated speed controls allow operators to easily maintain and achieve a milling pattern that meets visual or measured specifications in a wide variety of applications.



SAVE AND RECALL MILLING SPEED

Maintaining your milling speed is key to achieving a consistent cutting pattern. Once a rotor speed is selected and pattern is established, use of the cruise control button quickly stores the propel speed and repeatedly returns to that same speed throughout the day. This is particularly useful when finishing a cut and starting again in a different position.



TAKE A BREAK

Standby/Resume pauses major machine functions and lowers engine speed to conserve fuel during truck exchanges. When ready to resume milling, a push of the same button brings the machine back up to production at the same speed as before to maintain the same cutting pattern.

SPEED CONTROL WITH THE PUSH OF A BUTTON

Choose rotor and milling speed to achieve the desired pattern.



Press and hold **Cruise Control** button for two seconds to save your milling speed.



During truck exchanges, press the **Standby/Resume** button to pause the machine.



Press **Standby/Resume** again to continue milling at the same speed.



For each new cut, press the **Cruise Control** button to return to the saved milling speed.



INTEGRATED TECHNOLOGY

WHERE PRECISION MEETS PRODUCTIVITY



IMPROVE ACCURACY WITH AUTOMATED FEATURES

Take the guesswork out of producing accurate and repeatable cutting results by using automated features within the integrated Cat Grade and Slope system. The machine displays allow easy access to adjust elevation, slope settings and sensors through the highly intuitive touchscreen interface. Machine operators and ground personnel can conveniently take full control of grade settings from any of the available displays.



PLUNGE-CUT CAPABILITY

Adjust the speed at which the rotor drops into the cut for optimal machine control. Save your settings to reduce set up time for the next job.



OBSTACLE JUMP

Easily clear obstacles in the cutting path using the obstacle jump feature, accessible from both the operator station and ground level controls.



AUTOMATED CUT TRANSITION

Set and automate grade and slope transitions for tapered start or end cuts over a specified distance, eliminating the need for manual adjustments of the grade control targets.

3D 3D MILLING CAPABLE

Cat cold planers can be enhanced with full 3D milling capability to meet job specifications (additional hardware required).

ALL-DAY COMFORT



The work area can be set up for operator preference and working position. Touchscreen displays provide access to the gauge cluster, operating information, remote camera feeds, machine controls and diagnostics.

OPERATOR COMFORT

The workstation is designed for all-day comfort with adjustable consoles, large cushioned arm rests, hip rests, and optional anti-fatigue floor mats. Two consoles allow operation from either side of the machine and telescoping center displays bring the touchscreens fully within reach for comfortable interaction. The operator station can be equipped with pedestal seats that quickly pivot out of the way when not in use, or suspension seats for added comfort. Large, lockable, water-tight storage compartments keep items safe and secure.

MINIMIZE DUST

Optional dust extraction and spray bar systems are designed to maximize dust removal from the working area, contributing to cleaner air for the crew and surrounding environment.

POWER CANOPY

HASSLE-FREE COMFORT

Overhead obstacles are a challenge for almost any milling jobsite. The PM820, PM822 and PM825 feature an optional forward-folding power canopy that quickly stows and redeploys during operation with the simple push of a button.

The single post design maximizes visibility when raised and includes side extensions that deploy easily for additional protection from the elements. Overhead LED lighting illuminates the operator station. Optional windscreen panels can be installed for increased operator comfort.

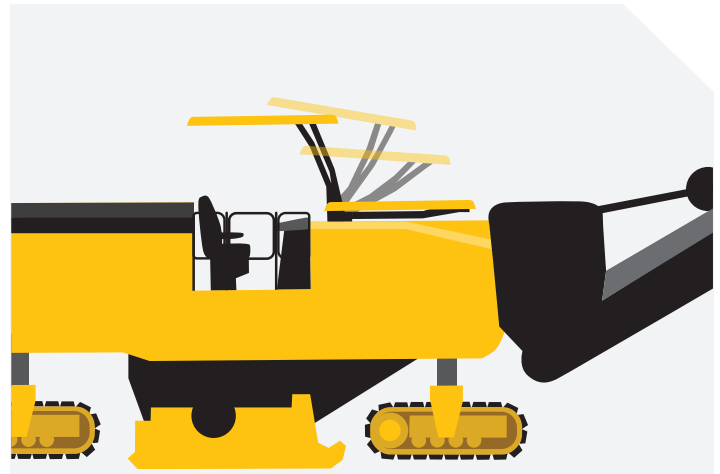

RAISE OR LOWER THE CANOPY
ON THE GO WITHOUT
INTERRUPTING PRODUCTION



10 SECONDS
OR LESS



SIMPLE CONTROLS

EASY TO LEARN. EASY TO USE.

Whether in the operator station or on the ground, access integrated technology and automated systems through easy-to-use controls. Four ground-level 16-button keypads give operators convenient access to various machine functions. All operator controls are backlit for low-light environments.

OPERATOR CONTROLS

Controls on the dual operator consoles are grouped by function and identified with intuitive keypad icons. Leg controls are conveniently located for easy access. Joysticks are used to adjust propel, steering and conveyor functions.

TOUCHSCREEN DISPLAYS

Highly intuitive touchscreens provide access to the gauge cluster, operating information, grade and slope, remote camera feeds, machine controls and diagnostics.

Ground displays have a robust mounting system that detaches quickly for relocation and storage without disconnecting any harnesses.



FRONT GROUND CONTROLS

Flush mounted front keypads include controls for the conveyor, sideplates, anti-slab, high pressure washdown, water spray, inboard ski, fuel fill pump, horn and emergency stop.

REAR GROUND CONTROLS

Rear keypads include controls for leg height, water spray, side plates, moldboard, rear door, rear steering, horn and emergency stop.

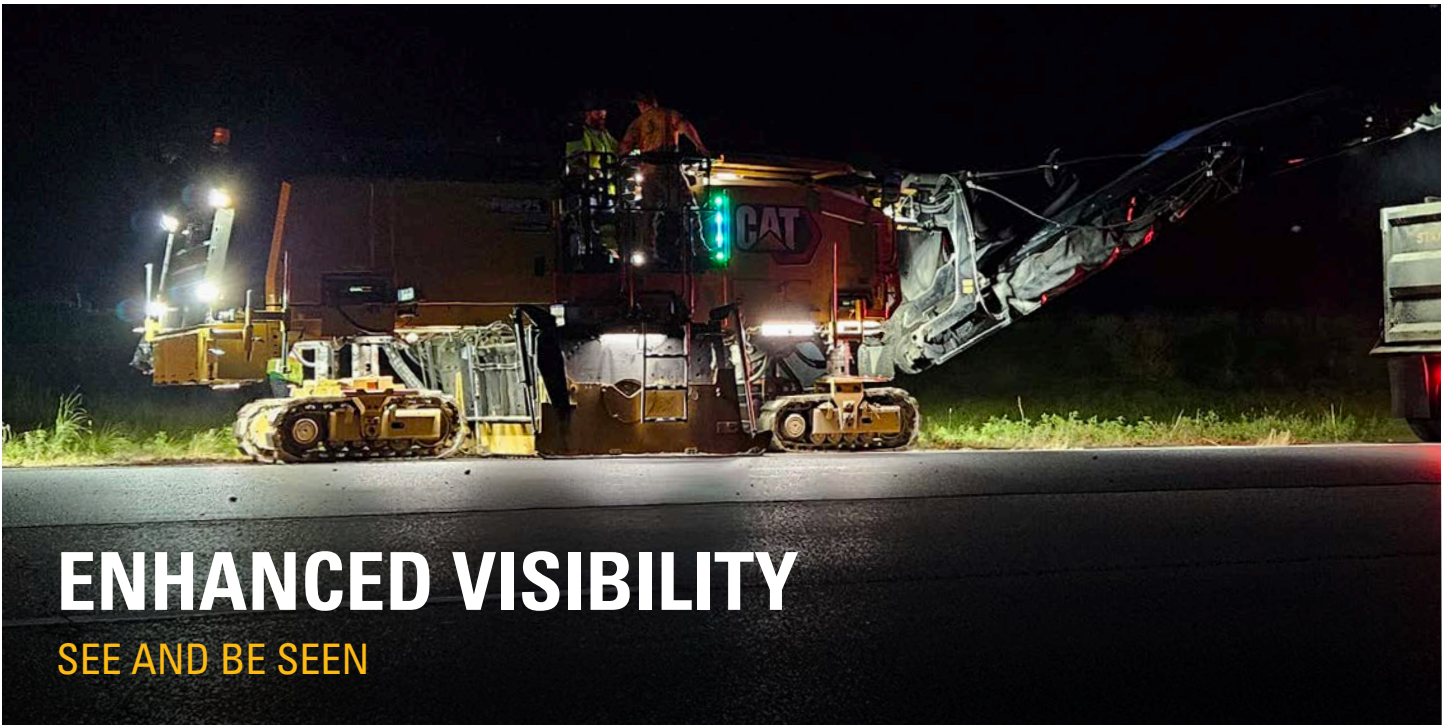

ENHANCED VISIBILITY

SEE AND BE SEEN

WORK AREA LIGHTING

Work areas around the machine are illuminated for nighttime visibility and operation with wide-dispersion LED work lights. Touchscreens automatically change to night mode when the work lights are activated. Upgrade to the enhanced LED lighting package that includes additional lighting for the work areas, illuminated water level indicators and additional work lights for rotor service.

REMOTE CAMERAS

Visibility to both cutting edges, conveyor and rear of the machine can be enhanced with up to four optional remote cameras, viewable through the main touchscreen display in the operator station.



DURABLE AND DEPENDABLE CUTTING SYSTEM

The robust cutting system is engineered to withstand some of the toughest applications and is built to last with heavy steel construction and reinforced alloys to resist abrasion.

DURABILITY DESIGNED IN

Engineered to maximize torque transfer, the rotor drive system features a heavy-duty dry clutch, automatic belt-tensioning and two high tensile (five-rib) belts to drive the rotor. The reinforced cutting chamber is designed to provide additional resistance against abrasion.



REDUCED WEAR AND MAINTENANCE

Hardened steel bolt-on wear skis run the full length of the side plates and wear shoes on the inboard skis and anti-slab assembly are designed to reduce wear and maintenance. The System K rotor toolholders, base blocks and kicker paddles are built from high-strength alloy steel that's abrasion resistant for extended life.



PRECISE CONTROL

Hydraulically controlled anti-slab, moldboard and side plates can be easily adjusted and locked into position, while the side plates also utilize position-sensing cylinders to act as an averaging ski for grade control. The moldboard applies adjustable downpressure to keep material contained and minimize sweeping. Visible indicators from the ground and operator station make it easy to identify the rotor position for various cut depths.

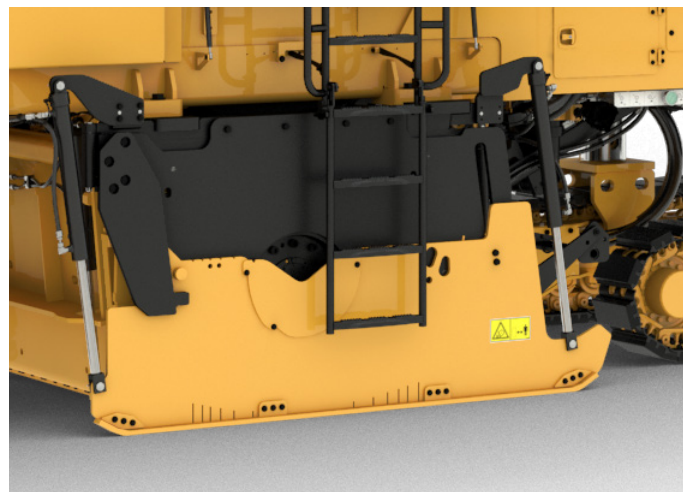

CAT SYSTEM K ROTORS

Cat System K rotors are engineered with precision to produce a uniform cutting pattern, efficiently remove material from the cutting chamber, and be easy to service. Built from high-strength alloy steel that's abrasion resistant for extended life, components stand up to the demands of high-power applications. A variety of bit spacings are available to match your application needs.

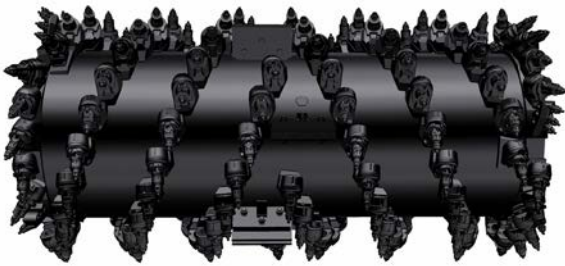

**MULTIPLE
WAYS TO
REMOVE BITS**



**TAPERED
DUAL-RETENTION
TOOLHOLDER**



**KICKER
PADDLES**



EASY BIT REMOVAL

System K rotors were designed to make changing cutter bits easier and faster. Bits can be removed through the radial access hole, chisel points, or the block, depending on what is easiest for you.

FASTENER-FREE TOOLHOLDERS

Toolholders are secured to the rotor without a retaining pin, bolt or setscrew, speeding up replacement and eliminating the need for torquing.

DIAMOND BITS

For bituminous applications without obstacles such as interstates or motorways, consider Cat Diamond bits. Designed to stay sharp and last significantly longer than a carbide bit, they help improve productivity, fuel efficiency and operating costs.

**DIAMOND BITS
STAY SHARP
LONGER
THAN CARBIDE BITS**

Results based on customer survey data of cold planer users in North America using diamond bits. Comparison between Cat 540 diamond bits and carbide bits. Average life and exact tonnage is impacted by local aggregate and operating technique.



TECHNOLOGY TO MEASURE,
MONITOR AND MANAGE

VISIONLINK® PRODUCTIVITY

While every jobsite engages in production, productivity remains a challenge for many. Low productivity means low revenue and has a direct impact on profitability. VisionLink® Productivity helps you measure, monitor, and manage your assets to maximize productivity – on or off the jobsite.

Understanding how your machine is being used each day can help you identify areas of improvement and better estimate for future jobs. Actionable information such as how much time is spent waiting for trucks, cutting, traveling around the jobsite, as well as distances cut, fuel burn details, location and cycle mapping is transmitted to the web platform for users to access anywhere via a mobile, tablet, or desktop device.

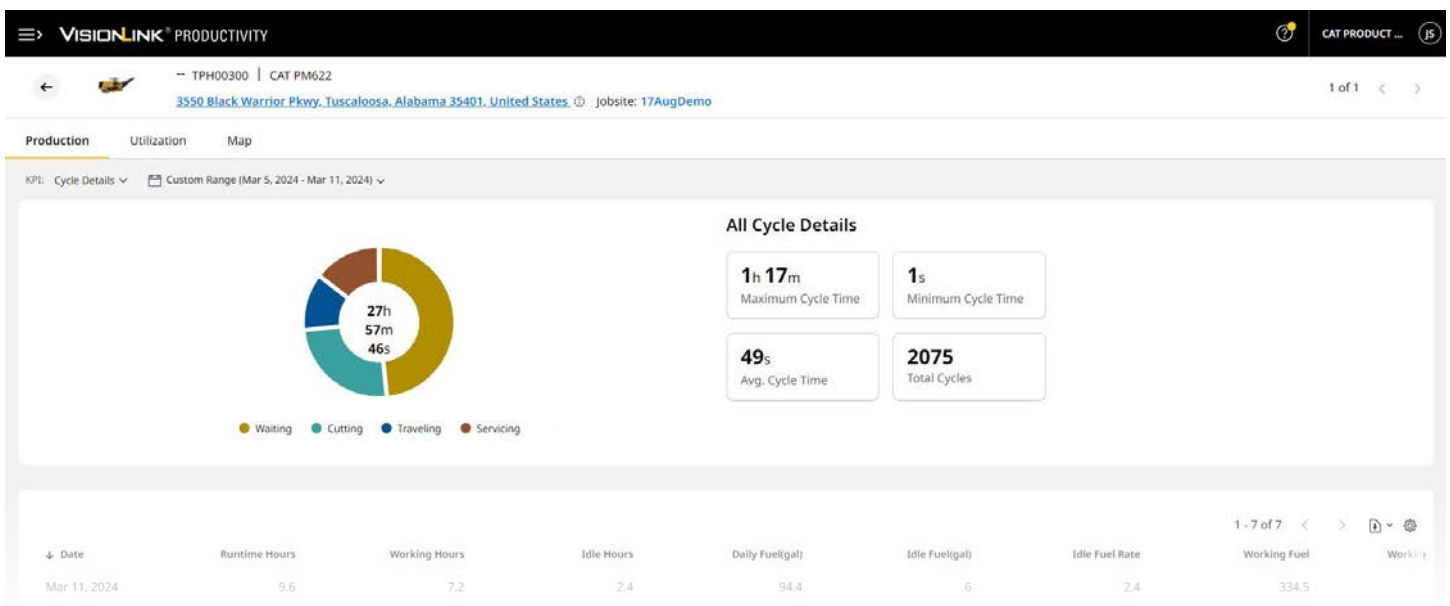

REVIEW CUTTING CYCLE DETAILS TO MEASURE AND IMPROVE EFFICIENCY



DIG DEEPER INTO WAITING TIMES AND IDENTIFY OPPORTUNITIES TO ELIMINATE WASTE



Sample data shown for illustration purposes only. Cat Payload for determining quantity of material milled is not available for cold planers.



SERVICEABILITY

DESIGNED RIGHT IN

Regular service and maintenance is key to keeping your machines functioning at optimal levels. The PM820, PM822 and PM825 were designed with long maintenance intervals, large service doors, and power hood for walk-in access to the engine compartment. Track components do not require routine maintenance and track pads can be easily replaced. When time to replace high wear components, your Cat dealer is ready to help with repair kits, convenient parts availability and service options for both your machine and the engine.

TIME SAVERS

Features to help make service quick and easy.

Ground-level controls and a hydraulically-operated rotor turning device with optional pendant aid in simplifying bit removal and replacement.

High and low pressure washdown options connect to the onboard water tank for convenient clean-up.

During maintenance and service, the accessory drive system allows for operation of select machine functions without needing to start the engine.

CAT EQUIPMENT MANAGEMENT TECHNOLOGY TAKES THE GUESSWORK OUT OF MANAGING YOUR EQUIPMENT

Cat equipment management telematics technology helps take the complexity out of managing your jobsites – by gathering data generated by your equipment, materials, and people and serving it up to you in customizable formats.



VISIONLINK®

VisionLink takes the guesswork out of managing your entire fleet – regardless of size or equipment manufacturer.* Review equipment data from your desktop or mobile device to maximize uptime and optimize assets. With interactive dashboards, VisionLink makes it easier for operations of all sizes to make informed decisions that lower costs, simplify maintenance, and improve safety and security on your jobsite. With different subscription-level options, your Cat dealer can help you determine what you need to connect your fleet and manage your business.

- + 24/7 Fleet Monitoring
- + Mixed Fleet Management
- + Optimize Fleet Utilization
- + Track Assets by Location
- + View Asset Health Status
- + Review Inspection Reports
- + Assign Maintenance Tasks
- + Minimize Downtime
- + Request Service and Order Parts
- + Download Summary Reports

** Data field availability can vary by equipment manufacturer.*



REMOTE SERVICES**

Remote Troubleshoot allows your Cat dealer to perform diagnostic testing on your connected machine remotely, pinpointing potential issues while the machine is in operation. Remote troubleshooting helps to ensure the technician arrives with the correct parts and tools the first time, eliminating additional trips to save you time and money.

Remote Flash allows you to update onboard software without a technician being present, allowing you to initiate software updates when convenient, increasing your overall operating efficiency.

*** Must be within cell range coverage.*



CAT INSPECT

Cat Inspect is a mobile application that allows you to easily perform digital preventative maintenance checks, inspections, and daily walkarounds. The app includes machine-specific Preventive Maintenance (PM) checklists to perform service intervals as recommended in the Operation and Maintenance Manual. Inspections can easily be integrated with other Cat data systems like VisionLink so you can keep a close eye on your fleet.

Caterpillar releases products, services and technologies in each region at different time intervals. Please verify with your local Cat dealer for technology availability and specifications.

TECHNICAL SPECIFICATIONS

POWERTRAIN

Engine Model	Cat® C18 twin-turbo
Cylinders	6
Emission Standards	U.S. EPA Tier 4 Final, EU Stage V
Gross Power – SAE J1995:2014	601 kW 806 hp
Engine Power – ISO 14396:2002	595 kW 798 hp
Build Number	02C
Maximum Milling Speed	100 m/min 328 ft/min
Maximum Travel Speed	6 km/h 3.7 mph

CUTTING SYSTEM

Milling Width	
PM820	2010 mm 79.1 in
PM822	2235 mm 88.0 in
PM825	2505 mm 98.6 in
Number of Bits (15 mm spacing)	
PM820	170
PM822	185
PM825	203
Maximum Cutting Depth	330 mm 13.0 in
Rotor Speeds	100 / 109 / 118 rpm
Minimum Left Cutting Radius	2.00 m 6.56 ft
Minimum Right Cutting Radius	
PM820	2.00 m 6.56 ft
PM822	1.80 m 5.91 ft
PM825	1.50 m 4.92 ft

WEIGHTS

Operating Weight	
PM820	34 088 kg 75,152 lb
PM822	34 565 kg 76,202 lb
PM825	35 175 kg 77,548 lb
Transport Weight	
PM820	32 859 kg 72,442 lb
PM822	33 336 kg 73,493 lb
PM825	33 946 kg 74,838 lb

Weights shown are approximate and include:

- Operating weight includes base machine with 75 kg (165 lb) operator, all standard equipment, power canopy, inboard ski, dust abatement system, high pressure wash system, 15 mm rotor, pedestal seats, floor mats, two ground displays, 50% water, 50% fuel and full operating fluids.
- Transport weight includes base machine, all standard equipment, power canopy, inboard ski, dust abatement system, high pressure wash system, 15 mm rotor, pedestal seats, floor mats, two ground displays, empty water, full fuel and other operating fluids.

SERVICE REFILL CAPACITIES

Fuel Tank	1108 L 292.7 gal
Cooling System	104 L 27.5 gal
Engine Oil	65 L 17.2 gal
Hydraulic Oil	113 L 29.9 gal
Water Tank	3400 L 898.2 gal

OPERATING DIMENSIONS

A Overall Length (conveyor raised)	14.52 m 47.64 ft
B Maximum Machine Width	
PM820	3.11 m 10.20 ft
PM822	3.11 m 10.20 ft
PM825	3.36 m 11.02 ft
B' Minimum Machine Width	
PM820	2.52 m 8.27 ft
PM822	2.74 m 8.99 ft
PM825	3.01 m 9.88 ft
C Maximum Height (conveyor raised)	5.23 m 17.16 ft
D Height to Optional Canopy	4.05 m 13.29 ft
E Height (canopy lowered/no canopy)	3.00 m 9.84 ft
F Maximum Truck Clearance	4.86 m 15.94 ft
G Conveyor Length	8.38 m 27.49 ft
H Conveyor Swing	±60° from center

SHIPPING DIMENSIONS

I Transport Length	12.43 m 40.78 ft
B' Transport Width	
PM820	2.52 m 8.27 ft
PM822	2.74 m 8.99 ft
PM825	3.01 m 9.88 ft
E Transport Height (canopy lowered)	3.00 m 9.84 ft
J Length (track to track)	6.69 m 21.95 ft
K Length of Machine (front track to rear)	7.32 m 24.02 ft
L Length of Base Machine	8.33 m 27.33 ft

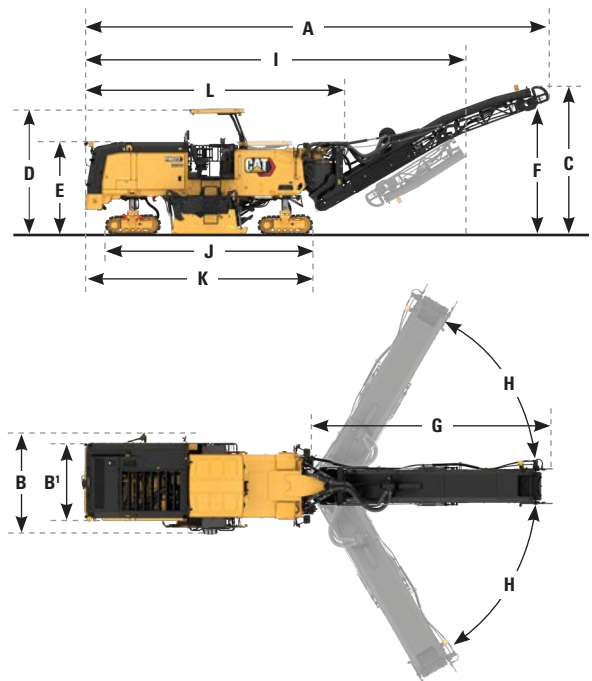

STANDARD & OPTIONAL EQUIPMENT

Features, standard and optional equipment may vary by region. Please check with your local Cat dealer for specific offerings and availability in your area.

OPERATOR ENVIRONMENT	STANDARD	OPTIONAL
Ground control keypads	●	
Single high-resolution LCD touchscreen display	●	
Dual high-resolution LCD touchscreen displays		○
12-Volt power receptacle	●	
Dual operator consoles with vertical adjustment	●	
Dual operator consoles with vertical, sideways, and rotational adjustment		○
Hydraulically folding canopy with LED lights and side extensions		○
Anti-fatigue floor mats		○
Adjustable pedestal seats		○
Adjustable suspension seats		○
Lockable 109x45x33 cm (43x18x13in) storage chest		○
Windscreens (front and rear)		○

CAT TECHNOLOGY		OPTIONAL
Remote Flash	●	
Remote Troubleshoot	●	
Cat Grade and Slope	●	
VisionLink® telematics	●	
VisionLink Productivity		○
Inboard ski		○
Single sonic grade control sensor		○
Sonic averaging system for grade control		○
High-resolution LCD touchscreen display (for ground level grade controls)		○

CONVEYOR	STANDARD	OPTIONAL
Grease tensioner (primary conveyor)	●	
Hydraulically folding conveyor	●	
Conveyor speed boost feature	●	
Dust extraction system		○
Additional spray bars (dust control)		○
Conveyor release valve		○

ROTOR SYSTEM	STANDARD	OPTIONAL
Automatic plunge-cut	●	
Automatic grade and slope transition feature	●	
Obstacle jump	●	
Three cutting speeds	●	
Powered rotor turning device	●	
Pendant control for rotor turning device		○
System K Rotor – Coarse (25 mm)		○
System K Rotor – Coarse (18 mm)		○
System K Rotor – Standard (15 mm)		○
System K Rotor – Fine (10 mm) (PM822 and PM825 only)		○
System K Rotor – Fine (8 mm)		○
System K Rotor – Micro (6 mm)		○
System H Rotor – Micro (6 x 2 mm) (PM820 and PM822 only)		○
Cat Diamond bits		○
Bit bucket trays		○
Pneumatic bit removal tool		
Toolholder extractor		○

POWERTRAIN	STANDARD	OPTIONAL
Engine Idle Speed Management	●	
High capacity cooling system	●	
Automatic Load Control	●	
CE certificate		○

Continued

STANDARD & OPTIONAL EQUIPMENT

Features, standard and optional equipment may vary by region. Please check with your local Cat dealer for specific offerings and availability in your area.

HYDRAULIC SYSTEM	STANDARD	OPTIONAL
Two independent hydraulic propel circuits	●	
Traction Control	●	
Cat Bio HYDO™ Advanced biodegradable hydraulic oil		○
High ambient hydraulic oil		○

SERVICE AND MAINTENANCE	STANDARD	OPTIONAL
Scheduled Oil Sampling (S•O•S SM) Ports	●	
Power hood	●	
Platform-level engine oil dipsticks	●	
Rotor chamber water spray system	●	
Air compressor	●	
Accessory drive system	●	
3400 L (898 gal) onboard water tank	●	
Side water fill valve	●	
Water tank transfer pump		○
High pressure washdown		○
Low pressure washdown		○
Fuel transfer pump		○
Fast fill fuel tank		○

SAFETY AND SECURITY	STANDARD	OPTIONAL
Platform handrails	●	
Signaling/warning horn	●	
Wide-dispersion LED work lighting	●	
Enhanced LED lighting package (perimeter, rotor service and water level)		○
Magnetic LED work light		○
Warning beacon (fixed or magnetic mount)		○
Truck signal lights		○
Remote cameras (rear back up, front conveyor, 2 magnetic mount)		○

For more complete information on Cat products, dealer services and industry solutions, visit us on the web at www.cat.com

© 2024 Caterpillar. All Rights Reserved.

Materials and specifications are subject to change without notice. Featured machines in photos may include additional equipment. See your Cat dealer for available options.

CAT, CATERPILLAR, LET'S DO THE WORK, their respective logos, "Caterpillar Corporate Yellow," the "Power Edge" and Cat "Modern Hex" trade dress as well as corporate and product identity used herein, are trademarks of Caterpillar and may not be used without permission. VisionLink is a trademark of Caterpillar Inc., registered in the United States and in other countries.

www.cat.com www.caterpillar.com

QEHQ3237 (11-2024)
Build Number: 02C
(N Am, Europe, Indonesia, Aus-NZ,
South Korea, Taiwan, Türkiye)

