



315

Hydraulic Excavator

Technical Specifications

Configurations and features may vary by region. Please consult your Cat® dealer for availability in your area.

Table of Contents

Specifications	2
Engine	2
Swing Mechanism	2
Weights	2
Track	2
Drive	2
Air Conditioning System	2
Hydraulic System	2
Service Refill Capacities	2
Standards	2
Sound Performance	2
Operating Weights and Ground Pressures	3
Major Component Weights	4
Dimensions	5
Working Ranges and Forces	6
Blade Working Ranges	7
Reach Boom Lift Capacities	8
Reach Boom Lift Capacities – Blade Up	11
Bucket Specifications and Compatibility:	
Australia and New Zealand	14
Attachments Offering Guide:	
Australia and New Zealand	15
Standard and Optional Equipment	16
Dealer Installed Kits and Attachments	18
Cab Options	19
315 Environmental Declaration	20

315 Hydraulic Excavator Specifications

Engine

Engine Model	Cat® C3.6	
Net Power		
ISO 9249	80.9 kW	108 hp
ISO 9249 (DIN)	110 hp (metric)	
Engine Power		
ISO 14396	82 kW	110 hp
ISO 14396 (DIN)	111 hp (metric)	
Bore	98 mm	4 in
Stroke	120 mm	5 in
Displacement	3.6 L	220 in ³
Biodiesel Capability	Up to B20 ⁽¹⁾	

- Emits equivalent to U.S. EPA Tier 3.
- No engine power derating required below 3000 m (9,840 ft) altitude.
- Advertised power is tested per the specified standard in effect at the time of manufacture.
- Net power advertised is the power available at the flywheel when the engine is equipped with fan, air intake system, exhaust system and alternator.
- Engine speed at 2,200 rpm.

⁽¹⁾Cat engines are compatible with diesel fuel blended with the following lower-carbon intensity fuels** up to:

- ✓ 100% biodiesel FAME (fatty acid methyl ester)*
- ✓ 100% renewable diesel, HVO (hydrotreated vegetable oil) and GTL (gas-to-liquid) fuels

Refer to guidelines for successful application. Please consult your Cat dealer or “Caterpillar Machine Fluids Recommendations” (SEBU6250) for details.

*For use of blends higher than 20% biodiesel, consult your Cat dealer.
** Tailpipe greenhouse gas emissions from lower-carbon intensity fuels are essentially the same as traditional fuels

Swing Mechanism

Swing Speed	12.0 rpm	
Maximum Swing Torque	35 kN·m	25,815 lbf·ft

Weights

Operating Weight	14 700 kg	32,400 lb
------------------	-----------	-----------

- Long undercarriage, Reach boom, R2.5 (8'2") stick, General Duty (GD) 0.53 m³ (0.69 yd³) bucket, 500 mm (20") triple grouser shoes and 3.83 mt (8,440 lb) counterweight.

Track

Optional Track Shoes Width	500 mm	20 in
Optional Track Shoes Width	600 mm	24 in
Number of Shoes (each side)	46	
Number of Track Rollers (each side)	7	
Number of Carrier Rollers (each side)	2	

Drive

Gradeability	35°/70%	
Maximum Travel Speed	5.6 km/h	3.5 mph
Maximum Drawbar Pull	129 kN	29,000 lbf

Air Conditioning System

The air conditioning system on this machine contains the fluorinated greenhouse gas refrigerant R134a (Global Warming Potential = 1430). The system contains 0.8 kg of refrigerant, which has a CO₂ equivalent of 1.144 metric tonnes.

Hydraulic System

Main System – Maximum Flow – Implement	276 L/min	73 gal/min
Maximum Pressure – Equipment – Normal	35 000 kPa	5,075 psi
Maximum Pressure – Travel	35 000 kPa	5,075 psi
Maximum Pressure – Swing	26 000 kPa	3,770 psi
Boom Cylinder – Bore	105 mm	4 in
Boom Cylinder – Stroke	1023 mm	40 in
Stick Cylinder – Bore	115 mm	5 in
Stick Cylinder – Stroke	1147 mm	45 in
Bucket Cylinder – Bore	95 mm	4 in
Bucket Cylinder – Stroke	939 mm	37 in

Service Refill Capacities

Fuel Tank Capacity	187 L	49 gal
Cooling System	15 L	4 gal
Engine Oil	8 L	2 gal
Final Drive (each)	3 L	1 gal
Hydraulic System (including tank)	85 L	22.5 gal
Hydraulic Tank	72 L	19 gal

Standards

Brakes	ISO 10265:2008
Cab/Rollover Protective Structure (ROPS)	ISO 12117-2:2008
Cab/Operator Protective Structures (OPG) (Optional)	ISO 10262:1998 Level II

315 Hydraulic Excavator Specifications

Operating Weights and Ground Pressures

Base Machine Configurations	500 mm (20") Triple Grouser Shoes		500 mm (20") Triple Grouser Shoes with Rubber Pad		500 mm (20") Rubber Track Shoes	
	Weight	Ground Pressure	Weight	Ground Pressure	Weight	Ground Pressure
	kg (lb)	kPa (psi)	kg (lb)	kPa (psi)	kg (lb)	kPa (psi)
Base Frame with Track Rollers and Carrier Roller						
3.83 mt (8,440 lb) Counterweight + Long Undercarriage Base Machine						
Reach Boom + R3.0 (9'10") Stick + 0.53 m ³ (0.69 yd ³) GD Bucket	14 800 (32,600)	44.1 (6.4)	15 300 (33,700)	45.6 (6.6)	14 900 (32,800)	44.4 (6.4)
Reach Boom + R2.5 (8'2") Stick + 0.53 m ³ (0.69 yd ³) GD Bucket	14 700 (32,400)	43.8 (6.4)	15 300 (33,700)	45.6 (6.6)	14 900 (32,800)	44.4 (6.5)

All operating weights include a 90% fuel tank with 75 kg (165 lb) operator.

Base Machine Configurations	600 mm (24") Triple Grouser Shoes		600 mm (24") Rubber Track Shoes	
	Weight	Ground Pressure	Weight	Ground Pressure
	kg (lb)	kPa (psi)	kg (lb)	kPa (psi)
Base Frame with Track Rollers and Carrier Roller				
3.83 mt (8,440 lb) Counterweight + Long Undercarriage Base Machine				
Reach Boom + R3.0 (9'10") Stick + 0.53 m ³ (0.69 yd ³) GD Bucket	15 100 (33,300)	37.5 (5.4)	15 200 (33,500)	37.8 (5.5)
Reach Boom + R2.5 (8'2") Stick + 0.53 m ³ (0.69 yd ³) GD Bucket	15 000 (33,100)	37.3 (5.4)	15 200 (33,500)	37.8 (5.5)

All operating weights include a 90% fuel tank with 75 kg (165 lb) operator.

315 Hydraulic Excavator Specifications

Major Component Weights

	kg	lb
Base Machine Weight: including upper frame, undercarriage, counterweight, without boom, stick, bucket, stick cylinder, bucket cylinders, tracks, blade, without 90% fuel tank, operator		
With Long Undercarriage	10 660	23,500
With Long Undercarriage (blade compatible)	10 940	24,100
Track Shoes:		
500 mm (20") Triple Grouser Track Shoes	1540	3,390
500 mm (20") Triple Grouser Track Shoes with Rubber Pad	2050	4,520
500 mm (20") Rubber Track Shoes	1670	3,680
600 mm (24") Triple Grouser Track Shoes	1810	4,000
600 mm (24") Rubber Track Shoes	1970	4,340
Two Boom Cylinders	240	530
Weight of 90% Fuel Tank and 75 kg (165 lb) Operator	210	460
Blades (without lines, cylinders, frame modifications):		
2500 mm (8'2") Blade for use with 500 mm (20") Track Shoes	440	960
2600 mm (8'6") Blade for use with 600 mm (24") Track Shoes	490	1,080
Counterweight:		
3830 kg (8,440 lb) Counterweight	3830	8,440
Swing Frame	1420	3,140
Undercarriage:		
Base Frame with Standard Track Rollers and Two Carrier Rollers	2690	5,930
Base Frame with Standard Track Rollers and Two Carrier Rollers (blade compatible)	2980	6,560
Booms (including lines, pins, stick cylinder):		
Reach Boom 4.65 m (15'3")	1030	2,270
Sticks (including lines, pins, bucket cylinder, bucket linkage):		
Reach Stick R2.5 (8'2")	590	1,300
Reach Stick R3.0 (9'10")	650	1,440
Buckets (without linkage, with tips and side cutters):		
0.53 m ³ (0.69 yd ³) GD Bucket	460	1,010
Two Bucket Pins	20	50
Quick Coupler:		
Pin Grabber Quick Coupler	210	470

315 Hydraulic Excavator Specifications

Dimensions

All dimensions are approximate and may vary depending on bucket selection.

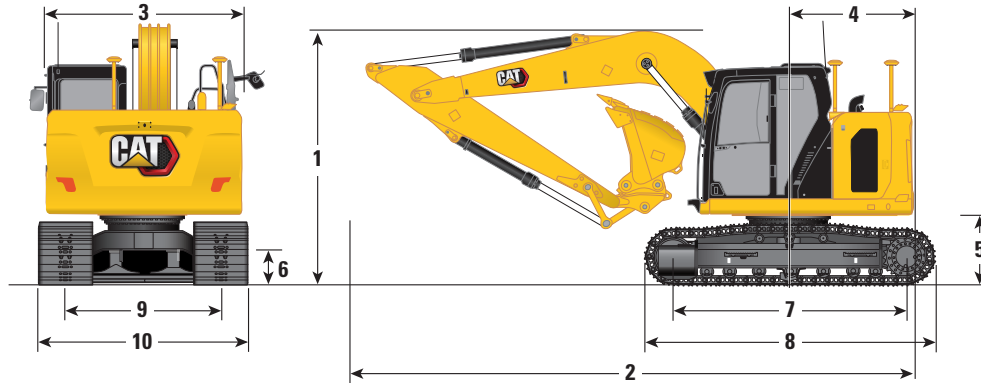

Boom Options

Reach Boom
4.65 m (15'3")

Stick Options

Reach Stick

R2.5 (8'2")

R3.0 (9'10")

1 Machine Height:*

	2810 mm	9'3"	2810 mm	9'3"
Top of Cab Height	2810 mm	9'3"	2810 mm	9'3"
Top of OPG Height	2960 mm	9'9"	2960 mm	9'9"
Handrail Height	2860 mm	9'5"	2860 mm	9'5"
With Boom/Stick/Bucket Installed (with stick cylinder lines)	2900 mm	9'6"	3190 mm	10'6"
With Boom/Stick Installed (with stick cylinder lines)	2820 mm	9'3"	3010 mm	9'11"
With Boom Installed (with stick cylinder lines)	2410 mm	7'11"	2410 mm	7'11"

2 Machine Length (without blade):

With Boom/Stick/Bucket Installed (with stick cylinder lines)	7450 mm	24'5"	7440 mm	24'5"
With Boom/Stick Installed (with stick cylinder lines)	7440 mm	24'5"	7490 mm	24'7"
With Boom Installed (with stick cylinder lines)	6510 mm	21'4"	6640 mm	21'9"

Machine Length (with blade, blade rear):

With Boom/Stick/Bucket Installed (with stick cylinder lines)	8020 mm	26'4"	8010 mm	26'3"
With Boom/Stick Installed (with stick cylinder lines)	8060 mm	26'5"	8060 mm	26'5"
With Boom Installed (with stick cylinder lines)	7210 mm	23'8"	7210 mm	23'8"

3 Upperframe Width

Upperframe Width	2480 mm	8'2"	2480 mm	8'2"
------------------	---------	------	---------	------

4 Tail Swing Radius – 3.83 mt (8,440 lb) Counterweight

Tail Swing Radius	1570 mm	5'2"	1570 mm	5'2"
-------------------	---------	------	---------	------

5 Counterweight Clearance

Counterweight Clearance	880 mm	2'11"	880 mm	2'11"
-------------------------	--------	-------	--------	-------

6 Ground Clearance

Ground Clearance	440 mm	1'5"	440 mm	1'5"
------------------	--------	------	--------	------

7 Track Length – Length to Center of Rollers

Track Length	3040 mm	10'0"	3040 mm	10'0"
--------------	---------	-------	---------	-------

8 Overall Track Length

Overall Track Length	3750 mm	12'4"	3750 mm	12'4"
----------------------	---------	-------	---------	-------

9 Track Gauge

Track Gauge	1990 mm	6'6"	1990 mm	6'6"
-------------	---------	------	---------	------

10 Track Width/Undercarriage Width (with/without steps):

500 mm (20") Shoes	2490 mm	8'2"	2490 mm	8'2"
600 mm (24") Shoes	2590 mm	8'6"	2590 mm	8'6"

Bucket Type

GD

GD

Bucket Capacity**

0.53 m ³	0.69 yd ³	0.53 m ³	0.69 yd ³
---------------------	----------------------	---------------------	----------------------

Bucket Tip Radius

1240 mm	4'1"	1240 mm	4'1"
---------	------	---------	------

*For models with rubber track shoes or rubber pad add 40 mm (1.6") to machine height dimensions.

315 Hydraulic Excavator Specifications

Working Ranges and Forces

All dimensions are approximate and may vary depending on bucket selection.

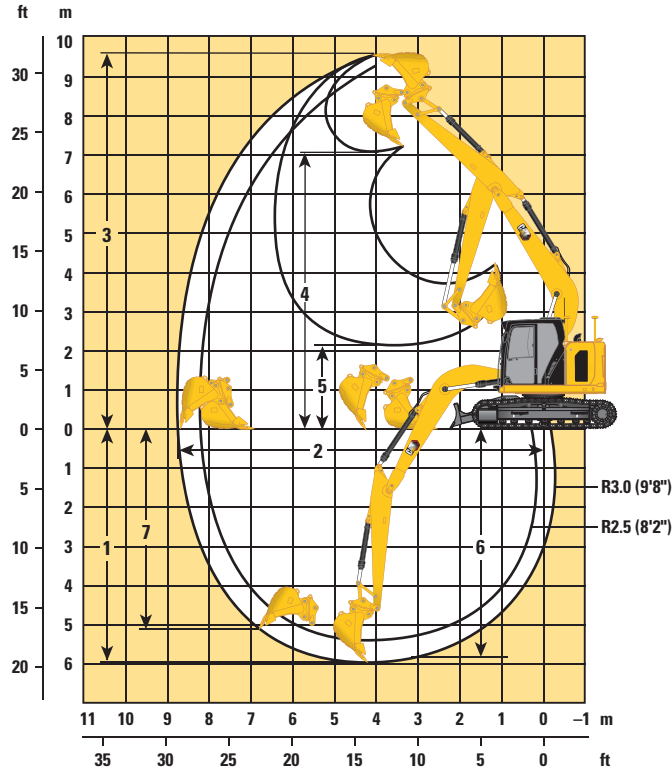

Boom Options

Reach Boom
4.65 m (15'3")

Stick Options

Reach Stick

	R2.5 (8'2")		R3.0 (9'10")	
	mm	ft	mm	ft
1 Maximum Digging Depth	5490	18'0"	5990	19'8"
2 Maximum Reach at Ground Line	8230	27'0"	8690	28'6"
3 Maximum Cutting Height	9330	30'7"	9690	31'9"
4 Maximum Loading Height	6850	22'6"	7220	23'8"
5 Minimum Loading Height	2530	8'4"	2080	6'10"
6 Maximum Depth Cut for 2440 mm (8'0") Level Bottom	5280	17'4"	5810	19'1"
7 Maximum Vertical Wall Digging Depth	4740	15'7"	5180	17'0"
Minimum Working Equipment Radius	1990	6'6"	2240	7'4"
Bucket Digging Force (ISO)	98.45 kN	22,130 lbf	98.67 kN	22,180 lbf
Stick Digging Force (ISO)	66.75 kN	15,010 lbf	59.29 kN	13,330 lbf
Bucket Type	GD		GD	
Bucket Capacity	0.53 m ³	0.69 yd ³	0.53 m ³	0.69 yd ³
Bucket Tip Radius	1240 mm	4'1"	1240 mm	4'1"

315 Hydraulic Excavator Specifications

Blade Working Ranges

All dimensions are approximate and may vary depending on bucket selection.

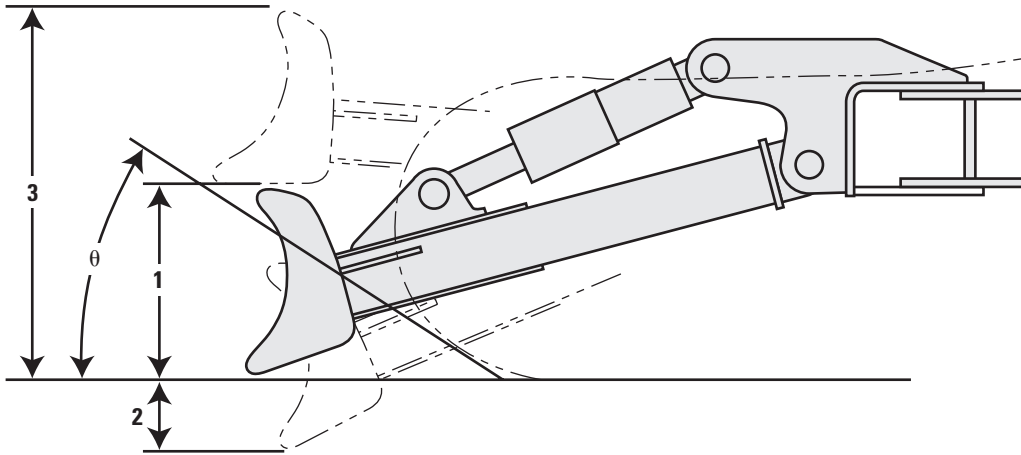

Blade Options	2500 mm (8'2")		2600 mm (8'6")	
	1 Blade Height	616 mm	2'0"	616 mm
2 Maximum Lowering Depth from Ground	550 mm	1'10"	550 mm	1'10"
3 Maximum Raising Height above Ground	1018 mm	3'4"	1018 mm	3'4"
θ Approach Angle	26°		26°	

315 Hydraulic Excavator Specifications

Reach Boom Lift Capacities – Counterweight: 3830 kg (8,440 lb) – without Bucket

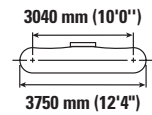
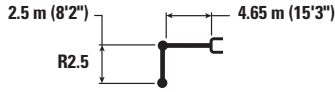

Reach Boom mm ft/in	kg lb	1500 mm (5'0")		3000 mm (10'0")		4500 mm (15'0")		6000 mm (20'0")		315 Hydraulic Excavator		mm ft/in
		ISO 10567:2007	ISO 10567:2007	ISO 10567:2007	ISO 10567:2007	ISO 10567:2007	ISO 10567:2007	ISO 10567:2007	ISO 10567:2007	ISO 10567:2007	ISO 10567:2007	
7500 mm 25'0"	kg lb			*4350 *9,200	*4350 *9,200					*3250 *7,450	*3250 *7,450	3710 11'5"
6000 mm 20'0"	kg lb					*4050 *8,750	*4050 *8,750			*2600 *5,800	*2600 *5,800	5490 17'8"
4500 mm 15'0"	kg lb			*4150 *9,050	*4150 *9,050	*4500 *9,750	4100 8,800	*3700 *7,600	2600 5,550	*2450 *5,350	2300 5,100	6460 21'0"
3000 mm 10'0"	kg lb			*7400 *15,850	7250 15,600	*5150 *11,150	3900 8,350	3950 8,450	2550 5,400	*2450 *5,350	2000 4,400	6970 22'9"
1500 mm 5'0"	kg lb			*6800 *16,700	6500 13,950	*5850 *12,600	3650 7,800	3800 8,200	2400 5,200	*2550 *5,600	1900 4,100	7130 23'4"
0 mm 0'0"	kg lb			*6250 *14,500	6200 13,300	5700 12,250	3450 7,400	3750 8,000	2350 5,000	*2850 *6,250	1900 4,200	6960 22'9"
-1500 mm -5'0"	kg lb	*4750 *10,700	*4750 *10,700	*7900 *17,150	6150 13,200	*5550 *11,950	3400 7,250	3700 7,950	2300 4,950	3350 7,400	2100 4,650	6440 21'0"
-3000 mm -10'0"	kg lb	*7300 *15,650	*7300 *15,650	*5750 *12,350	*5750 *12,350	*4150 *8,750	3400 7,350			*2950 *6,400	2650 5,900	5460 17'9"

Reach Boom Lift Capacities – Counterweight: 3830 kg (8,440 lb) – without Bucket

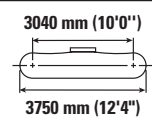
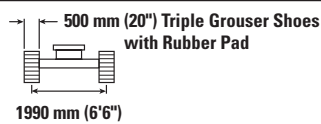

Reach Boom mm ft/in	kg lb	1500 mm (5'0")		3000 mm (10'0")		4500 mm (15'0")		6000 mm (20'0")		315 Hydraulic Excavator		mm ft/in
		ISO 10567:2007	ISO 10567:2007	ISO 10567:2007	ISO 10567:2007	ISO 10567:2007	ISO 10567:2007	ISO 10567:2007	ISO 10567:2007	ISO 10567:2007	ISO 10567:2007	
7500 mm 25'0"	kg lb			*4350 *9,200	*4350 *9,200					*3250 *7,450	*3250 *7,450	3710 11'5"
6000 mm 20'0"	kg lb					*4050 *8,750	*4050 *8,750			*2600 *5,800	*2600 *5,800	5490 17'8"
4500 mm 15'0"	kg lb			*4150 *9,050	*4150 *9,050	*4500 *9,750	4200 9,050	*3700 *7,600	2700 5,750	*2450 *5,350	2350 5,250	6460 21'0"
3000 mm 10'0"	kg lb			*7400 *15,850	*7400 *15,850	*5150 *11,150	4000 8,600	4050 8,750	2600 5,600	*2450 *5,350	2050 4,550	6970 22'9"
1500 mm 5'0"	kg lb			*6800 *16,700	6700 14,400	*5850 *12,600	3750 8,050	3950 8,500	2500 5,350	*2550 *5,600	1950 4,250	7130 23'4"
0 mm 0'0"	kg lb			*6250 *14,500	*6250 13,750	5900 12,700	3550 7,650	3850 8,300	2400 5,200	*2850 *6,250	2000 4,350	6960 22'9"
-1500 mm -5'0"	kg lb	*4750 *10,700	*4750 *10,700	*7900 *17,150	6350 13,650	*5550 *11,950	3500 7,500	3800 8,200	2400 5,100	*3400 *7,450	2200 4,800	6440 21'0"
-3000 mm -10'0"	kg lb	*7300 *15,650	*7300 *15,650	*5750 *12,350	*5750 *12,350	*4150 *8,750	3550 7,600			*2950 *6,400	2750 6,100	5460 17'9"



ISO 10567:2007



* Indicates that the load is limited by hydraulic lifting capacity rather than tipping load. The above loads are in compliance with hydraulic excavator lift capacity standard ISO 10567:2007.

They do not exceed 87% of hydraulic lifting capacity or 75% of tipping load. Weight of all lifting accessories must be deducted from the above lifting capacities. Lifting capacities are based on the machine standing on a firm, uniform supporting surface. The use of a work tool attachment point to handle/lift objects, could affect the machine lift performance.

Lift capacity stays with ±5% for all available track shoes.

Always refer to the appropriate Operation and Maintenance Manual for specific product information.

315 Hydraulic Excavator Specifications

Reach Boom Lift Capacities – Counterweight: 3830 kg (8,440 lb) – without Bucket

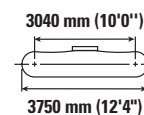
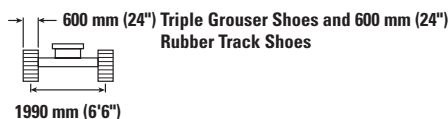
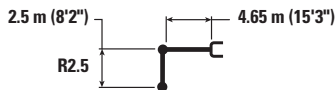

Reach Boom	1500 mm (5'0")		3000 mm (10'0")		4500 mm (15'0")		6000 mm (20'0")		3040 mm (10'0") 3750 mm (12'4")		mm ft/in
	kg lb	kg lb	kg lb	kg lb	kg lb	kg lb	kg lb	kg lb	kg lb	kg lb	
7500 mm 25'0"			*4350 *9,200	*4350 *9,200					*3250 *7,450	*3250 *7,450	3710 11'5"
6000 mm 20'0"					*4050 *8,750	*4050 *8,750			*2600 *5,800	*2600 *5,800	5490 17'8"
4500 mm 15'0"			*4150 *9,050	*4150 *9,050	*4500 *9,750	4150 8,950	*3700 *7,600	2650 5,650	*2450 *5,350	2350 5,150	6460 21'0"
3000 mm 10'0"			*7400 *15,850	7350 15,850	*5150 *11,150	3950 8,500	4000 8,600	2550 5,500	*2450 *5,350	2050 4,450	6970 22'9"
1500 mm 5'0"			*6800 *16,700	6600 14,200	*5850 *12,600	3700 7,950	3900 8,350	2450 5,300	*2550 *5,600	1900 4,200	7130 23'4"
0 mm 0'0"			*6250 *14,500	*6250 13,550	5800 12,500	3500 7,550	3800 8,150	2400 5,100	*2850 *6,250	1950 4,250	6960 22'9"
-1500 mm -5'0"	*4750 *10,700	*4750 *10,700	*7900 *17,150	6250 13,450	*5550 *11,950	3450 7,400	3750 8,100	2350 5,050	*3400 *7,450	2150 4,700	6440 21'0"
-3000 mm -10'0"	*7300 *15,650	*7300 *15,650	*5750 *12,350	*5750 *12,350	*4150 *8,750	3500 7,500			*2950 *6,400	2700 6,000	5460 17'9"

Reach Boom Lift Capacities – Counterweight: 3830 kg (8,440 lb) – without Bucket

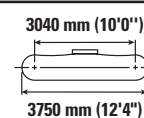
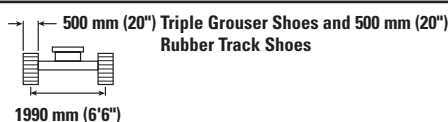

Reach Boom	1500 mm (5'0")		3000 mm (10'0")		4500 mm (15'0")		6000 mm (20'0")		7500 mm (25'0")		3040 mm (10'0") 3750 mm (12'4")		mm ft/in
	kg lb	kg lb	kg lb	kg lb	kg lb	kg lb	kg lb	kg lb	kg lb	kg lb	kg lb	kg lb	
7500 mm 25'0"					*2700 *2700	*2700 *2700					*2600 *5,850	*2600 *5,850	4540 14'3"
6000 mm 20'0"					*3450 *7,550	*3450 *7,550	*2400 *2400	*2400 *2400			*2200 *4,850	*2200 *4,850	6070 19'8"
4500 mm 15'0"					*3650 *7,950	*3650 *7,950	*3450 *7,400	2650 5,650			*2050 *4,500	2050 4,500	6960 22'8"
3000 mm 10'0"			*5850 *12,100	*5850 *12,100	*4800 *10,350	3950 8,500	*3950 *8,500	2550 5,450			*2050 *4,500	1800 3,950	7440 24'4"
1500 mm 5'0"			*8750 *18,800	6650 14,300	*5600 *12,050	3650 7,900	3850 8,200	2400 5,200	*2500 1750		*2150 *4,750	1700 3,700	7590 24'10"
0 mm 0'0"			*7000 *16,150	6200 13,300	5700 12,300	3450 7,400	3700 7,950	2300 4,950			*2400 *5,250	1700 3,750	7430 24'4"
-1500 mm -5'0"	*4300 *9,650	*4300 *9,650	*8500 *18,350	6100 13,050	5600 12,000	3350 7,200	3650 7,850	2250 4,850			*2850 *6,250	1850 4,100	6940 22'8"
-3000 mm -10'0"	*7450 *16,700	*7450 *16,700	*6650 *14,350	6150 13,150	*4700 *10,000	3350 7,200	*3000 6,600	2300 5,000			*2950 *6,400	2250 5,000	6050 19'8"
-4500 mm -15'0"			*3450 *7,050	*3450 *7,050							*2050 *4,250	*2050 *4,250	4490 14'4"



ISO 10567:2007



* Indicates that the load is limited by hydraulic lifting capacity rather than tipping load. The above loads are in compliance with hydraulic excavator lift capacity standard ISO 10567:2007. They do not exceed 87% of hydraulic lifting capacity or 75% of tipping load. Weight of all lifting accessories must be deducted from the above lifting capacities. Lifting capacities are based on the machine standing on a firm, uniform supporting surface. The use of a work tool attachment point to handle/lift objects, could affect the machine lift performance.

Lift capacity stays with ±5% for all available track shoes.

Always refer to the appropriate Operation and Maintenance Manual for specific product information.

315 Hydraulic Excavator Specifications

Reach Boom Lift Capacities – Counterweight: 3830 kg (8,440 lb) – without Bucket

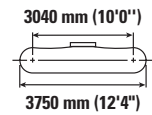
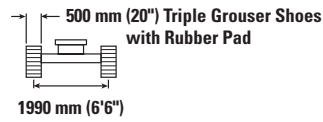
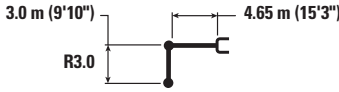

		1500 mm (5'0")		3000 mm (10'0")		4500 mm (15'0")		6000 mm (20'0")		7500 mm (25'0")		mm ft/in		
7500 mm 25'0"	kg lb					*2700	*2700					*2600 *5,850	*2600 *5,850	4540 14'3"
6000 mm 20'0"	kg lb					*3450 *7,550	*3450 *7,550	*2400	*2400			*2200 *4,850	*2200 *4,850	6070 19'8"
4500 mm 15'0"	kg lb					*3650 *7,950	*3650 *7,950	*3450 *7,400	2700 5,800			*2050 *4,500	*2050 *4,500	6960 22'8"
3000 mm 10'0"	kg lb			*5850 *12,100	*5850 *12,100	*4800 *10,350	4050 8,750	*3950 *8,550	2650 5,650			*2050 *4,500	1850 4,100	7440 24'4"
1500 mm 5'0"	kg lb			*8750 *18,800	6850 14,750	*5600 *12,050	3800 8,150	3950 8,500	2500 5,400	*2500 1800		*2150 *4,750	1750 3,850	7590 24'10"
0 mm 0'0"	kg lb			*7000 *16,150	6400 13,750	5900 12,700	3550 7,650	3850 8,250	2400 5,150			*2400 *5,250	1800 3,900	7430 24'4"
-1500 mm -5'0"	kg lb	*4300 *9,650	*4300 *9,650	*8500 *18,350	6300 13,500	*5750 *12,400	3450 7,450	3800 8,100	2350 5,050			*2850 *6,250	1950 4,250	6940 22'8"
-3000 mm -10'0"	kg lb	*7450 *16,700	*7450 *16,700	*6650 *14,350	6350 13,600	*4700 *10,000	3450 7,450	*3000	2350			*2950 *6,400	2350 5,200	6050 19'8"
-4500 mm -15'0"	kg lb			*3450 *7,050	*3450 *7,050							*2050 *4,250	*2050 *4,250	4490 14'4"

Reach Boom Lift Capacities – Counterweight: 3830 kg (8,440 lb) – without Bucket

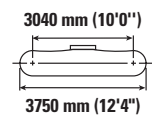
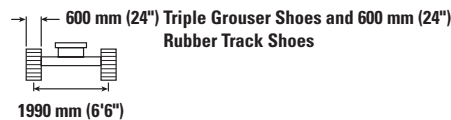
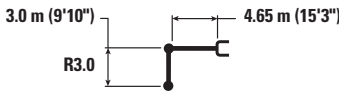

		1500 mm (5'0")		3000 mm (10'0")		4500 mm (15'0")		6000 mm (20'0")		7500 mm (25'0")		mm ft/in		
7500 mm 25'0"	kg lb					*2700	*2700					*2600 *5,850	*2600 *5,850	4540 14'3"
6000 mm 20'0"	kg lb					*3450 *7,550	*3450 *7,550	*2400	*2400			*2200 *4,850	*2200 *4,850	6070 19'8"
4500 mm 15'0"	kg lb					*3650 *7,950	*3650 *7,950	*3450 *7,400	2700 5,750			*2050 *4,500	*2050 *4,500	6960 22'8"
3000 mm 10'0"	kg lb			*5850 *12,100	*5850 *12,100	*4800 *10,350	4000 8,600	*3950 *8,550	2600 5,550			*2050 *4,500	1850 4,000	7440 24'4"
1500 mm 5'0"	kg lb			*8750 *18,800	6750 14,550	*5600 *12,050	3750 8,050	3900 8,350	2450 5,300	*2500 1750		*2150 *4,750	1750 3,800	7590 24'10"
0 mm 0'0"	kg lb			*7000 *16,150	6300 13,500	5850 12,500	3500 7,550	3800 8,100	2350 5,050			*2400 *5,250	1750 3,850	7430 24'4"
-1500 mm -5'0"	kg lb	*4300 *9,650	*4300 *9,650	*8500 *18,350	6200 13,300	5700 12,250	3400 7,300	3700 8,000	2300 4,950			*2850 *6,250	1900 4,200	6940 22'8"
-3000 mm -10'0"	kg lb	*7450 *16,700	*7450 *16,700	*6650 *14,350	6250 13,400	*4700 *10,000	3400 7,350	*3000	2350			*2950 *6,400	2300 5,100	6050 19'8"
-4500 mm -15'0"	kg lb			*3450 *7,050	*3450 *7,050							*2050 *4,250	*2050 *4,250	4490 14'4"



ISO 10567:2007



* Indicates that the load is limited by hydraulic lifting capacity rather than tipping load. The above loads are in compliance with hydraulic excavator lift capacity standard ISO 10567:2007. They do not exceed 87% of hydraulic lifting capacity or 75% of tipping load. Weight of all lifting accessories must be deducted from the above lifting capacities. Lifting capacities are based on the machine standing on a firm, uniform supporting surface. The use of a work tool attachment point to handle/lift objects, could affect the machine lift performance.

Lift capacity stays with ±5% for all available track shoes.

Always refer to the appropriate Operation and Maintenance Manual for specific product information.

315 Hydraulic Excavator Specifications

Reach Boom Lift Capacities – Counterweight: 3830 kg (8,440 lb) – without Bucket – Blade Up

2500 mm (8'2") Blade

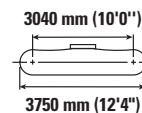
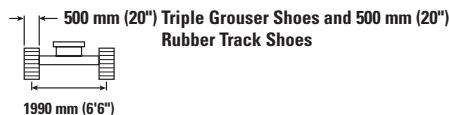

Diagram	1500 mm (5'0")		3000 mm (10'0")		4500 mm (15'0")		6000 mm (20'0")		Diagram		mm ft/in
	kg	lb	kg	lb	kg	lb	kg	lb	kg	lb	
7500 mm 25'0"			*4350 *9,200	*4350 *9,200					*3250 *7,450	*3250 *7,450	3710 11'5"
6000 mm 20'0"					*4050 *8,750	*4050 *8,750			*2600 *5,800	*2600 *5,800	5490 17'8"
4500 mm 15'0"			*4150 *9,050	*4150 *9,050	*4500 *9,750	4400 9,400	*3700 *7,600	2800 6,000	*2450 *5,350	*2450 *5,350	6460 21'0"
3000 mm 10'0"			*7400 *15,850	*7400 *15,850	*5150 *11,150	4150 8,950	4050 8,700	2750 5,850	*2450 *5,350	2150 4,750	6970 22'9"
1500 mm 5'0"			*6800 *16,700	*6800 15,050	*5850 *12,600	3900 8,450	3950 8,450	2600 5,600	*2550 *5,600	2050 4,500	7130 23'4"
0 mm 0'0"			*6250 *14,500	*6250 14,400	5900 12,650	3750 8,050	3850 8,250	2550 5,450	*2850 *6,250	2050 4,550	6960 22'9"
-1500 mm -5'0"	*4750 *10,700	*4750 *10,700	*7900 *17,150	6650 14,300	*5550 *11,950	3650 7,900	3800 8,200	2500 5,350	*3400 *7,450	2300 5,050	6440 21'0"
-3000 mm -10'0"	*7300 *15,650	*7300 *15,650	*5750 *12,350	*5750 *12,350	*4150 *8,750	3700 8,000			*2950 *6,400	2900 *6,400	5460 17'9"

Reach Boom Lift Capacities – Counterweight: 3830 kg (8,440 lb) – without Bucket – Blade Up

2500 mm (8'2") Blade

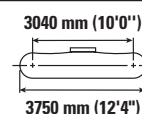
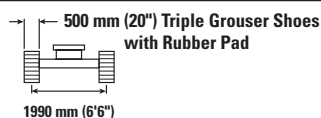

Diagram	1500 mm (5'0")		3000 mm (10'0")		4500 mm (15'0")		6000 mm (20'0")		Diagram		mm ft/in
	kg	lb	kg	lb	kg	lb	kg	lb	kg	lb	
7500 mm 25'0"			*4350 *9,200	*4350 *9,200					*3250 *7,450	*3250 *7,450	3710 11'5"
6000 mm 20'0"					*4050 *8,750	*4050 *8,750			*2600 *5,800	*2600 *5,800	5490 17'8"
4500 mm 15'0"			*4150 *9,050	*4150 *9,050	*4500 *9,750	4400 9,400	*3700 *7,600	2800 6,000	*2450 *5,350	*2450 *5,350	6460 21'0"
3000 mm 10'0"			*7400 *15,850	*7400 *15,850	*5150 *11,150	4150 8,950	4050 8,700	2750 5,850	*2450 *5,350	2150 4,750	6970 22'9"
1500 mm 5'0"			*6800 *16,700	*6800 15,050	*5850 *12,600	3900 8,450	3950 8,450	2600 5,600	*2550 *5,600	2050 4,500	7130 23'4"
0 mm 0'0"			*6250 *14,500	*6250 14,400	5900 12,650	3750 8,050	3850 8,250	2550 5,450	*2850 *6,250	2050 4,550	6960 22'9"
-1500 mm -5'0"	*4750 *10,700	*4750 *10,700	*7900 *17,150	6650 14,300	*5550 *11,950	3650 7,900	3800 8,200	2500 5,350	*3400 *7,450	2300 5,050	6440 21'0"
-3000 mm -10'0"	*7300 *15,650	*7300 *15,650	*5750 *12,350	*5750 *12,350	*4150 *8,750	3700 8,000			*2950 *6,400	2900 *6,400	5460 17'9"



ISO 10567:2007



* Indicates that the load is limited by hydraulic lifting capacity rather than tipping load. The above loads are in compliance with hydraulic excavator lift capacity standard ISO 10567:2007.

They do not exceed 87% of hydraulic lifting capacity or 75% of tipping load. Weight of all lifting accessories must be deducted from the above lifting capacities. Lifting capacities are based on the machine standing on a firm, uniform supporting surface. The use of a work tool attachment point to handle/lift objects, could affect the machine lift performance.

Lift capacity stays with ±5% for all available track shoes.

Always refer to the appropriate Operation and Maintenance Manual for specific product information.

315 Hydraulic Excavator Specifications

Reach Boom Lift Capacities – Counterweight: 3830 kg (8,440 lb) – without Bucket – Blade Up

2600 mm (8'6") Blade

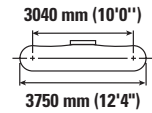
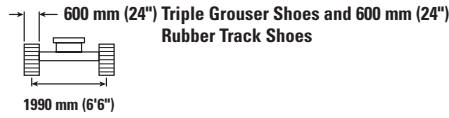
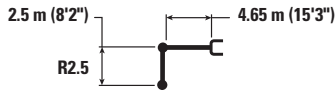

		1500 mm (5'0")		3000 mm (10'0")		4500 mm (15'0")		6000 mm (20'0")		mm ft/in		
7500 mm 25'0"	kg lb			*4350 *9,200	*4350 *9,200					*3250 *7,450	*3250 *7,450	3710 11'5"
6000 mm 20'0"	kg lb					*4050 *8,750	*4050 *8,750			*2600 *5,800	*2600 *5,800	5490 17'8"
4500 mm 15'0"	kg lb			*4150 *9,050	*4150 *9,050	*4500 *9,750	4350 9,350	*3700 *7,600	2750 5,900	*2450 *5,350	*2450 *5,350	6460 21'0"
3000 mm 10'0"	kg lb			*7400 *15,850	*7400 *15,850	*5150 *11,150	4150 8,900	4000 8,550	2700 5,800	*2450 *5,350	*2450 *5,350	6970 22'9"
1500 mm 5'0"	kg lb			*6800 *16,700	*6800 *16,700	*5850 *12,600	3850 8,350	3900 8,300	2600 5,550	*2550 *5,600	2000 4,400	7130 23'4"
0 mm 0'0"	kg lb			*6250 *14,500	*6250 *14,500	5800 12,450	3700 7,950	3800 8,100	2500 5,350	*2850 *6,250	2050 4,500	6960 22'9"
-1500 mm -5'0"	kg lb	*4750 *10,700	*4750 *10,700	*7900 *17,150	6600 14,150	*5550 *11,950	3650 7,800	3750 8,050	2450 5,300	*3400 *7,450	2250 4,950	6440 21'0"
-3000 mm -10'0"	kg lb	*7300 *15,650	*7300 *15,650	*5750 *12,350	*5750 *12,350	*4150 *8,750	3650 7,900			*2950 *6,400	2850 6,350	5460 17'9"

Reach Boom Lift Capacities – Counterweight: 3830 kg (8,440 lb) – without Bucket – Blade Up

2500 mm (8'2") Blade

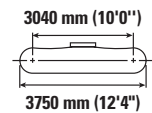
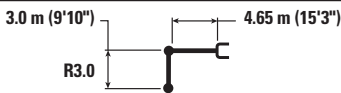

		1500 mm (5'0")		3000 mm (10'0")		4500 mm (15'0")		6000 mm (20'0")		7000 mm (25'0")		mm ft/in		
7500 mm 25'0"	kg lb					*2700 *2700						*2600 *5,850	*2600 *5,850	4540 14'3"
6000 mm 20'0"	kg lb					*3450 *7,550	*3450 *7,550	*2400 *2400				*2200 *4,850	*2200 *4,850	6070 19'8"
4500 mm 15'0"	kg lb					*3650 *7,950	*3650 *7,950	*3450 *7,400	2750 5,900			*2050 *4,500	*2050 *4,500	6960 22'8"
3000 mm 10'0"	kg lb			*5850 *12,100	*5850 *12,100	*4800 *10,350	4100 8,850	*3950 *8,500	2650 5,700			*2050 *4,500	1900 4,150	7440 24'4"
1500 mm 5'0"	kg lb			*8750 *18,800	6950 14,950	*5600 *12,050	3850 8,250	3800 8,200	2550 5,450	*2500 1800		*2150 *4,750	1800 3,900	7590 24'10"
0 mm 0'0"	kg lb			*7000 *16,150	6500 13,950	5700 12,250	3600 7,750	3700 7,950	2450 5,200			*2400 *5,250	1800 3,950	7430 24'4"
-1500 mm -5'0"	kg lb	*4300 *9,650	*4300 *9,650	*8500 *18,350	6400 13,700	5600 11,950	3500 7,550	3650 7,800	2400 5,100			*2850 *6,250	1950 4,300	6940 22'8"
-3000 mm -10'0"	kg lb	*7450 *16,700	*7450 *16,700	*6650 *14,350	6450 13,800	*4700 *10,000	3500 7,550	*3000 6,600	2400			*2950 *6,400	2400 5,250	6050 19'8"
-4500 mm -15'0"	kg lb			*3450 *7,050	*3450 *7,050							*2050 *4,250	*2050 *4,250	4490 14'4"



ISO 10567:2007



* Indicates that the load is limited by hydraulic lifting capacity rather than tipping load. The above loads are in compliance with hydraulic excavator lift capacity standard ISO 10567:2007. They do not exceed 87% of hydraulic lifting capacity or 75% of tipping load. Weight of all lifting accessories must be deducted from the above lifting capacities. Lifting capacities are based on the machine standing on a firm, uniform supporting surface. The use of a work tool attachment point to handle/lift objects, could affect the machine lift performance.

Lift capacity stays with ±5% for all available track shoes.

Always refer to the appropriate Operation and Maintenance Manual for specific product information.

315 Hydraulic Excavator Specifications

Reach Boom Lift Capacities – Counterweight: 3830 kg (8,440 lb) – without Bucket – Blade Up

2500 mm (8'2") Blade

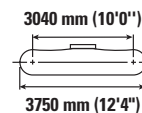
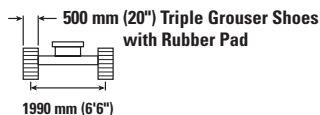
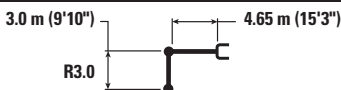

		1500 mm (5'0")		3000 mm (10'0")		4500 mm (15'0")		6000 mm (20'0")		7000 mm (25'0")		mm ft/in		
7500 mm 25'0"	kg lb					*2700	*2700					*2600 *5,850	*2600 *5,850	4540 14'3"
6000 mm 20'0"	kg lb					*3450 *7,550	*3450 *7,550	*2400	*2400			*2200 *4,850	*2200 *4,850	6070 19'8"
4500 mm 15'0"	kg lb					*3650 *7,950	*3650 *7,950	*3450	2850			*2050 *4,500	*2050 *4,500	6960 22'8"
3000 mm 10'0"	kg lb			*5850 *12,100	*5850 *12,100	*4800 *10,350	4250 9,100	*3950 *8,550	2750 5,900			*2050 *4,500	1950 4,300	7440 24'4"
1500 mm 5'0"	kg lb			*8750 *18,800	7150 15,400	*5600 *12,050	3950 8,500	3950 8,500	2600 5,650	*2500	1900	*2150 *4,750	1850 4,050	7590 24'10"
0 mm 0'0"	kg lb			*7000 *16,150	6700 14,400	5900 12,650	3750 8,050	3850 8,250	2500 5,400			*2400 *5,250	1850 4,100	7430 24'4"
-1500 mm -5'0"	kg lb	*4300 *9,650	*4300 *9,650	*8500 *18,350	6600 14,150	*5750 12,400	3650 7,800	3750 8,100	2450 5,300			*2850 *6,250	2050 4,450	6940 22'8"
-3000 mm -10'0"	kg lb	*7450 *16,700	*7450 *16,700	*6650 *14,350	6650 14,250	*4700 *10,000	3650 7,800	*3000	2500			*2950 *6,400	2450 5,450	6050 19'8"
-4500 mm -15'0"	kg lb			*3450 *7,050	*3450 *7,050							*2050 *4,250	*2050 *4,250	4490 14'4"

Reach Boom Lift Capacities – Counterweight: 3830 kg (8,440 lb) – without Bucket – Blade Up

2600 mm (8'6") Blade

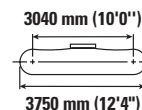
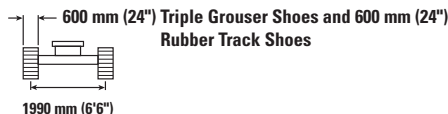
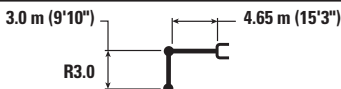

		1500 mm (5'0")		3000 mm (10'0")		4500 mm (15'0")		6000 mm (20'0")		7000 mm (25'0")		mm ft/in		
7500 mm 25'0"	kg lb					*2700	*2700					*2600 *5,850	*2600 *5,850	4540 14'3"
6000 mm 20'0"	kg lb					*3450 *7,550	*3450 *7,550	*2400	*2400			*2200 *4,850	*2200 *4,850	6070 19'8"
4500 mm 15'0"	kg lb					*3650 *7,950	*3650 *7,950	*3450	2800			*2050 *4,500	*2050 *4,500	6960 22'8"
3000 mm 10'0"	kg lb			*5850 *12,100	*5850 *12,100	*4800 *10,350	4200 9,000	*3950 *8,550	2700 5,800			*2050 *4,500	1950 4,250	7440 24'4"
1500 mm 5'0"	kg lb			*8750 *18,800	7100 15,250	*5600 *12,050	3900 8,400	3900 8,350	2600 5,550	*2500	1850	*2150 *4,750	1850 4,000	7590 24'10"
0 mm 0'0"	kg lb			*7000 *16,150	6650 14,250	5800 12,450	3700 7,950	3750 8,100	2500 5,350			*2400 *5,250	1850 4,050	7430 24'4"
-1500 mm -5'0"	kg lb	*4300 *9,650	*4300 *9,650	*8500 *18,350	6500 13,950	5700 12,200	3600 7,700	3700 7,950	2450 5,200			*2850 *6,250	2000 4,400	6940 22'8"
-3000 mm -10'0"	kg lb	*7450 *16,700	*7450 *16,700	*6650 *14,350	6550 14,100	*4700 *10,000	3600 7,700	*3000	2450			*2950 *6,400	2450 5,400	6050 19'8"
-4500 mm -15'0"	kg lb			*3450 *7,050	*3450 *7,050							*2050 *4,250	*2050 *4,250	4490 14'4"



ISO 10567:2007



* Indicates that the load is limited by hydraulic lifting capacity rather than tipping load. The above loads are in compliance with hydraulic excavator lift capacity standard ISO 10567:2007. They do not exceed 87% of hydraulic lifting capacity or 75% of tipping load. Weight of all lifting accessories must be deducted from the above lifting capacities. Lifting capacities are based on the machine standing on a firm, uniform supporting surface. The use of a work tool attachment point to handle/lift objects, could affect the machine lift performance.

Lift capacity stays with ±5% for all available track shoes.

Always refer to the appropriate Operation and Maintenance Manual for specific product information.

315 Hydraulic Excavator Specifications

Bucket Specifications and Compatibility – Australia and New Zealand

	Linkage	Width		Capacity		Weight		Fill %	3830 kg (8,440 lb) Counterweight		
		mm	in	m ³	yd ³	kg	lb		Reach Boom		Power Offset Boom*
									R2.5 (8'2")	R3.0 (9'10")	R2.2 (7'3")
Pin-On (No Quick Coupler)											
Utility Duty	312	450	18	0.20	0.26	256	565	100	●	●	●
	312	600	24	0.30	0.39	299	660	100	●	●	●
	312	900	36	0.50	0.65	388	856	100	●	●	●
General Duty	312	450	18	0.20	0.26	266	587	100	●	●	●
	312	600	24	0.31	0.40	310	684	100	●	●	●
	312	750	30	0.41	0.54	358	790	100	●	●	●
	312	750	30	0.41	0.54	410	903	100	●	●	●
	312	900	36	0.53	0.69	407	898	100	●	●	●
	312	900	36	0.53	0.69	451	994	100	●	●	●
	312	1050	42	0.65	0.84	457	1,006	100	●	●	●
Clean Up	312	1500	60	1.02	1.33	651	1,435	100	○	◇	⊖
	312	1800	72	1.29	1.68	748	1,649	100	◇	X	◇
Ditch Cleaning Tilt	312	1500	60	0.74	0.98	704	1,553	100	⊙	⊖	⊙
	312	1800	72	0.90	1.18	784	1,728	100	○	◇	⊖
Maximum load with pin-on (payload + bucket)								kg	1970	1760	2210
								lb	4,354	3,872	4,873
With Cat Pin Grabber Coupler											
Utility Duty	312	450	18	0.20	0.26	256	565	100	●	●	●
	312	600	24	0.30	0.39	299	660	100	●	●	●
	312	900	36	0.50	0.65	388	856	100	●	●	●
General Duty	312	450	18	0.20	0.26	266	587	100	●	●	●
	312	600	24	0.31	0.40	310	684	100	●	●	●
	312	750	30	0.41	0.54	358	790	100	●	●	●
	312	750	30	0.41	0.54	410	903	100	●	●	●
	312	900	36	0.53	0.69	407	898	100	●	●	●
	312	900	36	0.53	0.69	451	994	100	●	●	●
	312	1050	42	0.65	0.84	457	1,006	100	●	⊖	●
Clean Up	312	1500	60	1.02	1.33	651	1,435	100	◇	◇	○
	312	1800	72	1.29	1.68	748	1,649	100	X	X	◇
Ditch Cleaning Tilt	312	1500	60	0.74	0.98	704	1,553	100	⊖	○	⊖
	312	1800	72	0.90	1.18	784	1,728	100	◇	◇	○
Maximum load with coupler (payload + bucket)								kg	1775	1556	2011
								lb	3,913	3,431	4,433

The above loads are in compliance with hydraulic excavator standard EN474-5:2006 + A3:2013, they do not exceed 87% of hydraulic lifting capacity or 75% of tipping capacity with front linkage fully extended at ground line with bucket curled.

Capacity based on ISO 7451:2007.

*With blade

Maximum Material Density:

- 2100 kg/m³ (3,500 lb/yd³)
- ⊙ 1800 kg/m³ (3,000 lb/yd³)
- ⊖ 1500 kg/m³ (2,500 lb/yd³)
- 1200 kg/m³ (2,000 lb/yd³)
- ◇ 900 kg/m³ (1,500 lb/yd³)
- X Not Recommended

Caterpillar recommends using appropriate work tools to maximize the value customers receive from our products. Use of work tools, including buckets, which are outside of Caterpillar's recommendations or specifications for weight, dimensions, flows, pressures, etc. may result in less-than-optimal performance, including but not limited to reductions in production, stability, reliability, and component durability. Improper use of a work tool resulting in sweeping, prying, twisting and/or catching of heavy loads will reduce the life of the boom and stick.

315 Hydraulic Excavator Specifications

Attachments Offering Guide

Not all Attachments are available in all regions. Consult your Cat dealer for configurations available in your region.

Match

Working range front only

No Match

PIN-ON ATTACHMENTS

Counterweight		3.83 mt (8,440 lb)					
Boom Type		Reach			Variable Angle		
Stick Length		2.20 m (7'3")	2.50 m (8'2")	3.00 m (9'10")	2.20 m (7'3")	2.50 m (8'2")	3.00 m (9'10")
Hydraulic Hammers	H110 GC	✓	✓	✓			
	H110 GC S	✓	✓	✓	✓		
	H110 S	✓	✓	✓	✓	✓	✓
	H115 GC	✓	✓	✓			
	H115 GC S	✓	✓	✓			
	H115 S	✓	✓	✓			
Mulchers	HM2615	✓	✓	✓	✓	✓	✓
	HM3013	✓	✓	✓			
Compactors (Vibratory Plate)	CVP75	✓	✓	✓	✓	✓	✓
Rotary Cutters	RC10	✓	✓	✓	✓	✓	✓
	RC15	✓	✓	✓			

CAT PIN GRABBER COUPLER ATTACHMENTS

Counterweight		3.83 mt (8,440 lb)					
Boom Type		Reach			Variable Angle		
Stick Length		2.20 m (7'3")	2.50 m (8'2")	3.00 m (9'10")	2.20 m (7'3")	2.50 m (8'2")	3.00 m (9'10")
Hydraulic Hammers	H110 GC	✓	✓	✓			
	H110 GC S	✓	✓	✓			
	H110 S	✓	✓	✓			
	H115 GC	✓	✓	✓*			
	H115 GC S	✓	✓	✓			
	H115 S	✓	✓	✓			
Mulchers	HM2615	✓	✓	✓			
Compactors (Vibratory Plate)	CVP75	✓	✓	✓	✓	✓	✓
Rotary Cutters	RC10	✓	✓	✓	✓	✓	✓
	RC15	✓	✓	✓			

TRS10 (PIN-ON TOP/S60 BOTTOM) ATTACHMENTS

Some attachments require more hydraulic flow and are best suited with a machine that has HP2 circuits and a tiltrotator with a high flow swivel. Check the hydraulic capability of your machine and tiltrotator and the requirements of your attachment to ensure a proper match.

Counterweight		3.83 mt (8,440 lb)		
Boom Type		Reach		
Stick Length		2.20 m (7'3")	2.50 m (8'2")	3.00 m (9'10")
Hydraulic Hammers	H110 GC S	✓	✓	✓*
	H110 S	✓	✓	✓
Compactors (Vibratory Plate)	CVP75	✓	✓	✓

NOTE: Use hammers on tiltrotators less than 10% of working hours per year or maximum 200 hours per year. Refer to your Operation and Maintenance Manual for recommended hydraulic flow requirements.

315 Standard and Optional Equipment

Standard and Optional Equipment

Standard and optional equipment may vary. Consult your Cat dealer for details.

	Standard	Optional		Standard	Optional
BOOMS, STICKS AND LINKAGES			ELECTRICAL SYSTEM		
4.65 m (15'3") Reach boom	✓		Maintenance free battery	✓	
2.2 m (7'3") Reach stick		✓	Centralized electrical disconnect switch	✓	
2.5 m (8'2") Reach stick		✓	LED chassis light, left-hand/right-hand boom lights, cab lights	✓	
3.0 m (9'10") Reach stick		✓	Programmable time-delay LED working lights	✓	
Bucket linkage, with lifting eye, Cat Grade	✓		360° lighting		✓
CAT TECHNOLOGY			ENGINE		
Cat Equipment Management:			Cat® C3.6 single turbo diesel engine		
– VisionLink®	✓ ¹		Three selectable modes: Power, Smart, Eco	✓	
– VisionLink Productivity		✓ ²	One-touch low idle with automatic engine speed control	✓	
– Remote Flash	✓		Automatic engine shutdown	✓	
– Remote Troubleshoot	✓		52° C (125° F) high-ambient cooling capacity without derate	✓	
– Work tool recognition and tracking (PL161)	✓		–25° C (–13° F) cold start capability	✓	
– Operator Coaching		✓ ³	Electric fuel priming pump	✓	
Cat Grade:			Variable speed fan (viscous clutch type)		
– Cat Grade with 2D	✓		Single fuel filtration system	✓	
– Cat Grade with 2D with Attachment Ready Option (ARO)		✓	Sealed double element air filter with integrated pre-cleaner	✓	
– Laser catcher		✓			
– Cat Grade with 3D (single or dual Global Navigation Satellite System [GNSS])		✓			
– Compatible with 3D grade systems from Trimble, Topcon, and Leica	✓				
– Cat Grade 3D Ready		✓			
– Cat Grade Connectivity		✓ ²			
Cat Assist:					
– Grade Assist	✓				
– Boom Assist	✓				
– Bucket Assist	✓				
– Swing Assist	✓				
– Lift Assist	✓				
Cat Payload:					
– On-the-go weighing	✓				
– Semiautomatic calibration	✓				
– Payload/cycle information	✓				
– VisionLink Productivity back office reporting		✓ ²			
Cat Advanced Payload:					
– Daily totals		✓			
– Custom lists		✓			
– Smart weight target		✓			
– E-ticket Integration		✓ ²			
Other:					
Cat Tiltrotator (TRS) integration		✓			

¹Provides core telematics data to manage health, maintenance insights, and condition monitoring. Other plans available for more comprehensive data reporting. Consult your Cat dealer for details.

²VisionLink subscription required. Consult your Cat dealer for details.

³VisionLink subscription required for back office reporting. Consult your Cat dealer for details.

(continued on next page)

Standard and Optional Equipment (continued)

Standard and optional equipment may vary. Consult your Cat dealer for details.

	Standard	Optional		Standard	Optional
HYDRAULIC SYSTEM			UNDERCARRIAGE AND STRUCTURES		
Boom and stick regeneration circuits	✓		Grease lubricated track link	✓	
Automatic hydraulic oil warm up	✓		Center track guiding guards	✓	
Automatic two-speed travel	✓		Bottom guards	✓	
Electric main control valve	✓		Travel motor guards	✓	
Boom and stick drift reduction valve	✓		Swivel guard	✓	
Swing Drive	✓		500 mm (20") triple grouser track shoes		✓
Electric boom snubber	✓		500 mm (20") triple grouser track shoes with rubber pad		✓
Boom and stick lowering check valves		✓	500 mm (20") rubber track shoes		✓
Medium-pressure line		✓	600 mm (24") triple grouser track shoes		✓
High-pressure line		✓	600 mm (24") rubber track shoes		✓
Quick coupler line		✓	2500 mm (8'2") blade		✓
SAFETY AND SECURITY			2600 mm (8'6") blade		✓
Cat Detect – People Detection		✓	3.83 mt (8,440 lb) counterweight	✓	
Cat Command remote control		✓	Tie-down points on base frame	✓	
2D E-Fence:	✓				
– E-ceiling					
– E-floor					
– E-swing					
– E-wall					
– E-cab avoidance					
Rear and right-side-view cameras	✓				
360° visibility		✓			
Right-hand handrail and hand hold	✓				
Ground level engine shutoff switch	✓				
Swing alarm		✓			
Lockable disconnect switch	✓				
Service platform with anti-skid plate and countersunk bolts	✓				
Signaling/warning horn	✓				
Inspection lighting		✓			
Operator Protective Guards		✓			
SERVICE AND MAINTENANCE					
Grouped engine oil and fuel filters	✓				
Ground level engine oil dipstick	✓				
Scheduled Oil Sampling (S·O·S SM) ports	✓				
Integrated vehicle health management system	✓				

Dealer Installed Kits and Attachments

Attachments may vary. Consult your Cat dealer for details.

- | | | |
|--|--|---|
| CAB <ul style="list-style-type: none">• Left-hand and right-hand electrical pedal (two-way) for tool control• Dual exit rear window kit• Rain protector plus cab light cover• Front windshield laminated glass (P5A glass, EU demolition regulation)• Key fob (for use with Bluetooth receiver) | GUARDS <ul style="list-style-type: none">• Operator Protective Guards (OPG) (not compatible with cab light cover, rain protector)• Mesh guard full front (not compatible with cab light cover, rain protector)• Mesh guard lower half front• Full protecting vandalism guard | SAFETY AND SECURITY <ul style="list-style-type: none">• 76 mm (3") retractable seat belt |
|--|--|---|

Cab Options

	Deluxe
ROPS	●
Operator Protective Structures (OPG)	○
High-resolution 254 mm (10") LCD touchscreen monitor	●
Auto bi-level air conditioner	●
Jog dial and shortcut keys for monitor control	●
Keyless push-to-start engine control	●
Height-adjustable console	●
Tilt-up left-side console	●
Heated air-suspension seat	●
51 mm (2") seat belt	●
Monitor integrated Bluetooth radio with USB/Auxiliary ports	●
12V DC outlets	●
Document storage	●
Overhead storage and rear storage with nets	●
Beverage holder	●
Cup holder	●
Openable two-piece front window	●
Rear window emergency exit	●
Radial wiper with washer	●
Openable polycarbonate skylight hatch	●
LED dome light	●
Floor welcome light	●
Roof sunscreen	●
Roller front sunscreen	●
Roller rear sunscreen	○
Washable floor mat	●
Beacon ready	●
Cat Stick Steer	○
Auxiliary relay	○

● Standard

○ Optional

315 Environmental Declaration

The following information applies to the machine at the time of final manufacture as configured for sale in the regions covered in this document. The content of this declaration is valid as of the date issued; however, content related to machine features and specifications are subject to change without notice. For additional information, please see the machine's Operation and Maintenance Manual.

For more information on sustainability in action and our progress, please visit <https://www.caterpillar.com/en/company/sustainability>.

Engine

- The Cat® C3.6 engine emits equivalent to U.S. EPA Tier 3.
- Cat engines are compatible with diesel fuel blended with the following lower-carbon intensity fuels** up to:
 - ✓ 100% biodiesel FAME (fatty acid methyl ester)*
 - ✓ 100% renewable diesel, HVO (hydrotreated vegetable oil) and GTL (gas-to-liquid) fuels

Refer to guidelines for successful application. Please consult your Cat dealer or “Caterpillar Machine Fluids Recommendations” (SEBU6250) for details.

*For use of blends higher than 20% biodiesel, consult your Cat dealer.

**Tailpipe greenhouse gas emissions from lower-carbon intensity fuels are essentially the same as traditional fuels

Air Conditioning System

- The air conditioning system on this machine contains the fluorinated greenhouse gas refrigerant R134a (Global Warming Potential = 1430). The system contains 0.8 kg (1.8 lb) of refrigerant which has a CO₂ equivalent of 1.144 metric tonnes (1.261 tons).

Paint

- Based on best available knowledge, the maximum allowable concentration, measured in parts per million (PPM), of the following heavy metals in paint are:
 - Barium < 0.01%
 - Cadmium < 0.01%
 - Chromium < 0.01%
 - Lead < 0.01%

Oils and Fluids

- Caterpillar factory fills with ethylene glycol coolants. Cat Diesel Engine Antifreeze/Coolant (DEAC) and Cat Extended Life Coolant (ELC) can be recycled. Consult your Cat dealer for more information.
- Cat Bio HYDO™ Advanced is an EU Ecolabel approved biodegradable hydraulic oil.
- Additional fluids are likely to be present, please consult the Operations and Maintenance Manual or the Application and Installation guide for complete fluid recommendations and maintenance intervals.

Features and Technology

- The following features and technology may contribute to fuel savings and/or carbon reduction. Features may vary. Consult your Cat dealer for details.
 - Advanced hydraulic systems balance power and efficiency
 - Smart mode matches machine power to digging requirements automatically
 - Eco mode supports reduced fuel consumption for light applications
 - One-touch low idle with automatic engine speed control
 - Increase operating efficiency with standard Cat technologies that help lower operator fatigue and operating costs
 - Extended service intervals help decrease maintenance costs
 - Remote Flash and Remote Troubleshoot

Recycling

- The materials included in machines are categorized as below with approximate weight percentage. Because of variations of product configurations, the following values in the table may vary.

Material Type	Weight Percentage
Steel	84.65%
Iron	4.60%
Nonferrous Metal	1.71%
Mixed Metal	0.33%
Mixed-Metal and Nonmetal	2.20%
Plastic	0.07%
Rubber	1.54%
Mixed Nonmetallic	1.33%
Fluid	2.20%
Other	1.37%
Uncategorized	0.00%
Total	100%

- A machine with higher recyclability rate will ensure more efficient usage of valuable natural resources and enhance End-of-Life value of the product. According to ISO 16714:2008 (Earthmoving machinery – Recyclability and recoverability – Terminology and calculation method), recyclability rate is defined as percentage by mass (mass fraction in percent) of the new machine potentially able to be recycled, reused, or both.

All parts in the bill of material are first evaluated by component type based on a list of components defined by the ISO 16714:2008 and Japan CEMA (Construction Equipment Manufacturers Association) standards. Remaining parts are further evaluated for recyclability based on material type.

Because of variations of product configurations, the following value in the table may vary.

Recyclability – 95%

For more complete information on Cat products, dealer services, and industry solutions, visit us on the web at www.cat.com

© 2024 Caterpillar
All rights reserved

Materials and specifications are subject to change without notice. Featured machines in photos may include additional equipment. See your Cat dealer for available options.

CAT, CATERPILLAR, LET'S DO THE WORK, their respective logos, "Caterpillar Corporate Yellow," the "Power Edge" and Cat "Modern Hex" trade dress as well as corporate and product identity used herein, are trademarks of Caterpillar and may not be used without permission. VisionLink is a trademark of Caterpillar Inc., registered in the United States and in other countries.

AEXQ4119-00 (11-2024)
Build Number: 07H
(Aus-NZ, Singapore)

