



AD30

Underground Mining Truck

Technical Specifications

Configurations and features may vary by region. Please consult your Cat® dealer for availability in your area.

Table of Contents

Specifications	2
Engine	2
Operating Specifications	2
Weights	2
Weight Distribution	2
Transmission	2
Final Drives	2
Body Hoist	2
Body Capacities	2
Turning Dimensions	3
Service Refill Capacities	3
Tires	3
Standards	3
Dimensions	4
Gradeability/Speed/Rimpull	5
Standard and Optional Equipment	6



AD30 Underground Mining Truck Specifications

Engine

Engine Model	Cat® C15	
Engine Power – VR Engine – ISO 14396:2002	299 kW	401 hp
Engine Power – U.S. EPA Tier 3 Engine – ISO 14396:2002	299 kW	401 hp
Bore	137.2 mm	5.4 in
Stroke	171.5 mm	6.8 in
Displacement	15.2 L	928 in ³

- Power ratings apply at a rated speed of 1,800 rpm when tested under the reference conditions for the specified standard.
- All rating conditions are based on ISO/TR14396:2002, inlet air standard conditions with a total barometric pressure of 100 kPa (29.5 in Hg), with a vapor pressure of 1 kPa (0.295 in Hg), and 25° C (77° F). Performance measured using fuel to EPA specifications in 40 CFR Part 1065 and EU specifications in Directive 97/68/EC with a density of 0.845-0.850 kg/L @ 15° C (7.05-7.09 lb/gal @ 59° F) and fuel inlet temperature 40° C (104° F).
- Engine derate will commence at an altitude of 2743 m (8,999 ft).
- Optional Ventilation Reduction package available.
- Optional engine with emissions equivalent to Tier 3 and EU Stage IIIA is also available.

Operating Specifications

Nominal Payload Capacity	30 000 kg	66,139 lb
Gross Machine Mass	60 000 kg	132,300 lb

Weights

Operating Mass*	28 870 kg	63,647 lb
Front Axle	19 479 kg	42,944 lb
Rear Axle	9391 kg	20,704 lb
Operating Mass + Rated Payload*	60 000 kg	132,277 lb
Front Axle	26 513 kg	58,451 lb
Rear Axle	33 487 kg	73,826 lb

*Calculated weight.

Weight Distribution

Empty		
Front Axle	67.5%	
Rear Axle	32.5%	
Loaded		
Front Axle	44.2%	
Rear Axle	55.8%	

Transmission

Forward 1	6.3 km/h	3.9 mph
Forward 2	11.3 km/h	7 mph
Forward 3	20.8 km/h	12.9 mph
Forward 4	36.7 km/h	22.8 mph
Reverse 1	7.1 km/h	4.4 mph

- Maximum travel speeds with standard 26.5 × R25 tires.

Final Drives

Differential Ratio	3.38:1	
Final Drive Ratio	4.76:1	
Total Reduction Ratio	16.13:1	

- Fully floating axles.

Body Hoist

Raise	10.5 Seconds	
Lower	11.2 Seconds	
Total Cycle Time	21.7 Seconds	

Body Capacities

Body 1	11.3 m ³	14.8 yd ³
Body 2 (Standard Body)	14.4 m ³	18.8 yd ³
Body 3	17.5 m ³	22.9 yd ³
Wide Body	16.8 m ³	21.9 yd ³
Ejector Body	15.2 m ³	19.9 yd ³
Ejector Body	16.8 m ³	21.9 yd ³

- Heaped SAE 2:1.

AD30 Underground Mining Truck Specifications

Turning Dimensions

Outside Clearance Radius	8571 mm	337.4 in
Inner Clearance Radius	5030 mm	198 in
Frame Oscillation	10 Degrees	
Articulation Angle	42.5 Degrees	

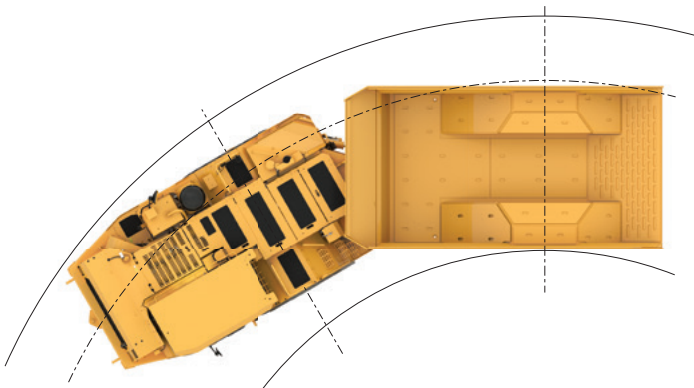

Service Refill Capacities

Engine Crankcase with Filter	34 L	9 gal
Transmission	67 L	18 gal
Hydraulic Tank	145 L	38 gal
Cooling System	74 L	20 gal
Front Differentials and Final Drives	56 L	15 gal
Rear Differentials and Final Drives	56 L	15 gal
Fuel Tank	410 L	108 gal

Tires

Tire Size	26.5 × R25
-----------	------------

Standards

Rollover Protective Structure (ROPS)/Falling Object Protective Structure (FOPS) Certified Cab

AD30 Underground Mining Truck Specifications

Dimensions

All dimensions are approximate.

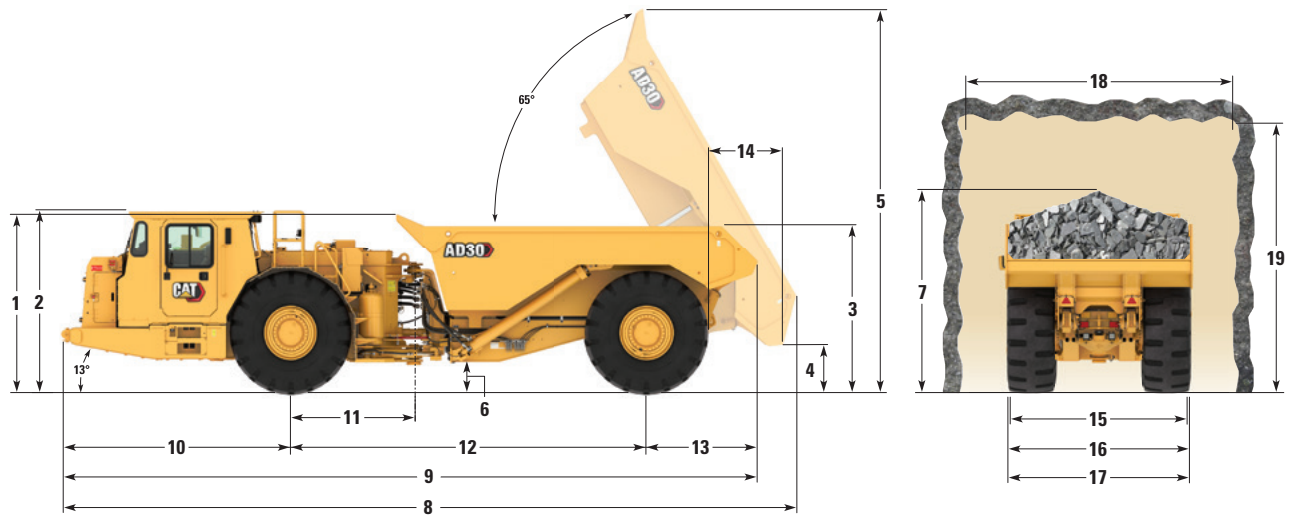

	613-7031		613-7034		613-7036		613-7037		613-7027		613-7029	
	Dump Body		Dump Body (std)		Dump Body		Wide Body		Ejector Body		Ejector Body	
Body Capacity	11.3 m ³	11.8 yd ³	14.4 m ³	18.8 yd ³	17.5 m ³	22.9 yd ³	16.8 m ³	21.9 yd ³	15.2 m ³	19.9 yd ³	16.8 m ³	21.9 yd ³
	mm	in	mm	in	mm	in	mm	in	mm	in	mm	in
1 Height – Top of Empty Body	2547	100.3	2547	100.3	2722	107.2	2547	100.3	2934	115.5	2934	115.5
2 Height – Top of ROPS	2600	102.4	2600	102.4	2600	102.4	2600	102.4	2600	102.4	2600	102.4
3 Height – Body Loading	2285	90.0	2385	93.9	2560	100.8	2295	90.4	2616	103.0	2791	109.9
4 Height – Dump Clearance**	594	23.4	558	22.0	547	21.5	270	10.6	703	27.7	703	27.7
5 Height – Top of Raised Body	5608	220.8	5602	220.6	5838	229.8	5485	216	—	—	—	—
6 Height – Ground Clearance	400	15.7	400	15.7	400	15.7	400	15.7	400	15.7	400	15.7
7 Height – Top of Load (SAE 2:1)	2953	116.3	3051	120.1	3264	128.5	3040	119.7	3284	129.3	3459	136.2
8 Length – Maximum Overall Length	10 697	421.1	10 743	423.0	10 830	426.4	10 830	426.4	10 393	409.2	10 393	409.2
9 Length – Overall Body Down	10 118	398.3	10 153	399.7	10 160	400.0	10 455	411.6	10 393	409.2	10 393	409.2
10 Length – Front Axle to Front Bumper	3345	131.7	3345	131.7	3345	131.7	3345	131.7	3345	131.7	3345	131.7
11 Length – Front Axle to Hitch	1800	70.9	1800	70.9	1800	70.9	1800	70.9	1800	70.9	1800	70.9
12 Length – Wheel Base	5200	204.7	5200	204.7	5200	204.7	5200	204.7	5200	204.7	5200	204.7
13 Length – Rear Axle to Tail	1573	61.9	1608	62.7	1615	63.6	1910	75.2	1848	72.8	1848	72.8
14 Length – Rear Wheel to Raised Body	1075	42.3	1061	41.8	1058	41.7	1180	46.5	1848	72.8	1848	72.8
15 Width – Overall Tire	2650	104.3	2650	104.3	2650	104.3	3000	118.1	2650	104.3	2650	104.3
16 Width – Machine with Body	2690	105.9	2690	105.9	2840	111.8	3040	119.7	2898	114.1	2898	114.1
17 Width – Machine without Body	2690	105.9	2690	105.9	2690	105.9	2690	105.9	2690	105.9	2690	105.9
18 Recommended Clearance Width*	4000	157.5	4000	157.5	4000	157.5	4000	157.5	4000	157.5	4000	157.5
19 Recommended Clearance Height* (SAE 2:1)	4000	157.5	4000	157.5	4000	157.5	4000	157.5	4000	157.5	4000	157.5

*Clearance dimensions are for reference only.

**Measurement taken with tailgate down for ejector body.

AD30 Underground Mining Truck Specifications

Gradeability/Speed/Rimpull

To determine gradeability performance: Read from gross weight down to the percent of total resistance. Total resistance equals actual percent grade plus rolling resistance as a general guide use 2 percent for rolling resistance in underground application or refer to the Caterpillar Performance Handbook. From the total resistance point, read horizontally to the curve with the highest obtainable gear, then down to maximum speed. Usable rimpull will depend upon traction available and weight on drive wheels.

—— Typical Field Empty Weight
 Loaded Weight

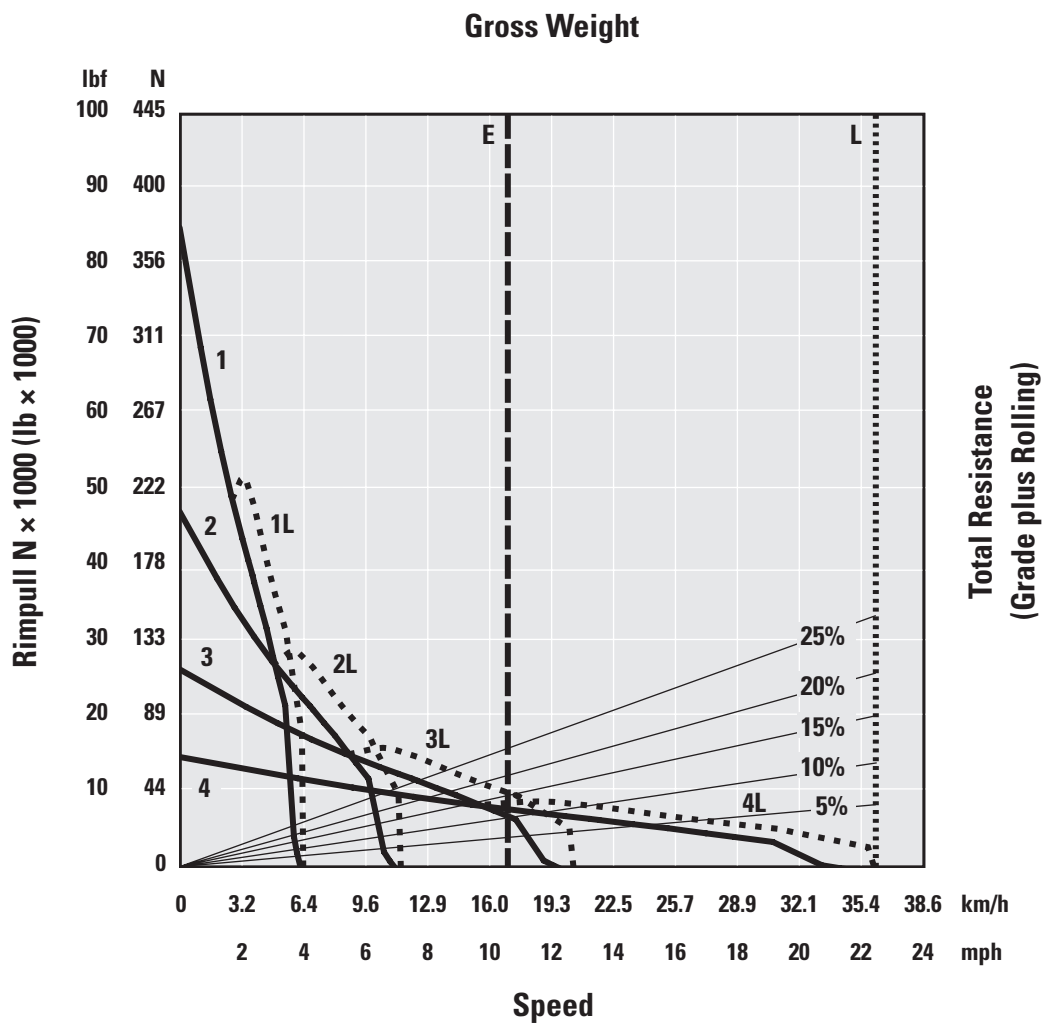

1 – 1st Gear
 2 – 2nd Gear
 3 – 3rd Gear
 4 – 4th Gear

E – Empty 28 870 kg (63,647 lb)
 L – Loaded 60 000 kg (132,277 lb)

AD30 Standard and Optional Equipment

Standard and Optional Equipment

Standard and optional equipment may vary. Consult your Cat dealer for details.

	Standard	Optional		Standard	Optional
POWER TRAIN			ELECTRICAL		
Axle, arrangement			12V power supply in cab	✓	
– Standard width, front – rear	✓		Alarm, reversing	✓	
– Wide body, front – rear		✓	Alternator, 95 amp	✓	
Brake retarder control, automatic	✓		Battery disconnect switch, ground level	✓	
Brake pressure gauges		✓	Battery shutdown:		✓
Brakes:	✓		– Ground Level Isolation, In Cab Isolation Switch		
– All wheel disc			– Ground Level Isolation, Engine Shutdown Switch		
– Oil cooled			– Ground Level Isolation, In Cab Isolation, Engine Shutdown Switch		
– Multiple-disc (SAFR™)			Circuit breaker, 80-amp	✓	
Control throttle shifting	✓		Corrosive protection spray	✓	
Electric fuel priming pump	✓		Diagnostic connector	✓	
Engine:	✓		Disconnect switch, two post, ground level	✓	
– Cat C15 six cylinder diesel engine			Electric starting, 24-volt	✓	
– Air-to-air aftercooler (ATAAC)			Lights		
Engine options:		✓	– Headlights with dimmer switch	✓	
– Engine, Ventilation Reduction (VR)			– Headlights with dimmer switch, LED		✓
– Equivalent to Tier 3			– Brake and tail lights	✓	
After treatment options (for use with VR engine only) Diesel Particulate Filter (DPF) (flow through) filter		✓	– Reversing lights, automatic when reverse gear selected	✓	
Exhaust, turbo compartment shielding	✓		– Reversing lights, automatic when reverse gear selected, LED		✓
Fast Fill System:		✓	– Work light, rear, cab mounted	✓	
– Coolant			– Work light, rear, cab mounted, LED		✓
– Engine oil			Low maintenance batteries	✓	
– Fuel (dual tanks)			Receptacle group, auxiliary start	✓	
– Hydraulic oil			Shutdown switch, ground level	✓	
– Transmission oil			Starting and charging system	✓	
Four wheel drive	✓				
Gear blockout with tray up, programmable	✓				
Ground speed limiting, programmable	✓				
Long life coolant	✓				
Parking brakes, four wheels	✓				
Park Brake Switch Engagement – Push to Apply/Pull to Apply		✓			
Precleaner, engine air intake	✓				
Radiator cap manual release	✓				
Radiator, cross flow	✓				
Secondary steering system	✓				
Transmission, automatic planetary power shift (4F/1R)	✓				
Torque converter with automatic lockup	✓				

(continued on next page)

Standard and Optional Equipment *(continued)*

Standard and optional equipment may vary. Consult your Cat dealer for details.

	Standard	Optional		Standard	Optional
OPERATOR ENVIRONMENT			TECHNOLOGY		
Cab, ROPS/FOPS certified	✓		Vital Information Management System (VIMS) Gen 3		✓
Open operator station ROPS/FOPS structure	✓		Payload:		✓
Operator's station ROPS/FOPS enclosed:		✓	– Truck Payload Measurement System (TPMS)		
– Air conditioning			TIRES, RIMS, AND WHEELS		
– Cab pressurizer and filter			Tires must be selected from the Mandatory Attachments section.	✓	
– Dome light			Choose from below:		
– Heater			– Tire, 26.5 × 25 VSNT Bridgestone		
– Radio ready compartment for radio and speakers			– Tire, 26.5 × 25 VSDL Bridgestone		
– Sun visor			Rims (set of four) – five pieces, tubeless	✓	
– Window, sliding cab door			Rim identification numbering		✓
Caterpillar Electronic Monitoring System (CEMS), dash instrument panels	✓		Spare rim, tubeless		✓
Operator Presence System	✓				
Automatic Brake Application (ABA)	✓				
Electric horns	✓				
Gauges:	✓				
– Engine coolant temperature					
– Transmission coolant temperature					
– Hydraulic oil temperature					
– Fuel level					
– Speedometer					
– Tachometer					
Indicator lights:	✓				
– Alert warning light					
– Body up position warning					
– High beam					
– Residual brake pressure warning					
– Retarder application					
– Turn signal					
Low hydraulic level warning	✓				
Mirrors, rear view	✓				
Seat, suspension operator seat with retractable seat belt	✓				
Seat:		✓			
– Suspension seat Cat Comfort TLV2, vinyl					
– Suspension seat tee, mechanical					
Seat cover:		✓			
– Tee and Cat Comfort TLV2					
– Seat cover, companion					
Seat, trainer/passenger with seat belt	✓				
Steering wheel, tilt/telescopic	✓				

(continued on next page)

AD30 Standard and Optional Equipment

Standard and Optional Equipment *(continued)*

Standard and optional equipment may vary. Consult your Cat dealer for details.

	Standard	Optional		Standard	Optional
OTHER STANDARD AND OPTIONAL EQUIPMENT			OTHER STANDARD AND OPTIONAL EQUIPMENT <i>(continued)</i>		
Adapters, oil sample	✓		Fuel system manual shut off tap	✓	
Alarm, tray up	✓		Front rubber bumpers	✓	
Body dump and ejector			Handholds (access on/off top deck)	✓	
– Dump, (11.3 m ³ /14.8 yd ³)		✓	Handrails	✓	
– Dump, (14.4 m ³ /18.8 yd ³)	✓		Hitch, articulated and oscillated	✓	
– Dump, (16.8 m ³ /21.9 yd ³)		✓	Lifting lugs, frame	✓	
– Dump, (17.5 m ³ /22.9 yd ³)		✓	Lubrication system		
– Ejector, (15.2 m ³ /19.9 yd ³)		✓	– Centralized, dump body	✓	
– Ejector, (16.8 m ³ /21.9 yd ³)		✓	– Automatic, dump or ejector body		✓
Body liners, impact and/or wear		✓	– Centralized, ejector body		✓
Camera – color rear facing		✓	Mine transfer		✓
Cover, anti vandalism for shipping		✓	Operation and Maintenance Manual – English and other applicable local languages to select	✓	
Cap, radiator, manual release	✓		Reflective tapes		✓
Catalytic exhaust purifier/muffler group	✓		Scheduled Oil Sampling (S·O·S SM) port:	✓	
Centralized lubrication points	✓		– Coolant		
Fenders			– Engine oil		
– Front, rear flaps	✓		– Hydraulic oil		
– Wide body, front, rear flaps		✓	– Transmission oil		
Firewall	✓		Service tools		✓
Fire suppression system:		✓	Spill guard, front, for body	✓	
– Foam, water based			Swing out radiator grill	✓	
Fluids:		✓	Tow pin, front and rear	✓	
– Arctic fuel					
– Arctic coolant					

For more complete information on Cat products, dealer services, and industry solutions, visit us on the web at www.cat.com

AEXQ3472-01(11-2024)
(Global)

© 2024 Caterpillar
All rights reserved

Materials and specifications are subject to change without notice. Featured machines in photos may include additional equipment. See your Cat dealer for available options.

CAT, CATERPILLAR, LET'S DO THE WORK, their respective logos, "Caterpillar Corporate Yellow," the "Power Edge" and Cat "Modern Hex" trade dress as well as corporate and product identity used herein, are trademarks of Caterpillar and may not be used without permission.

