



# AD45

## Underground Articulated Truck

# Technical Specifications

Configurations and features may vary by region. Please consult your Cat® dealer for availability in your area.

### Table of Contents

<b>Specifications</b> .....	<b>2</b>
Engine .....	2
Operating Specifications .....	2
Weights	
Stage V Engine Model .....	2
Other Engine Models .....	2
Weight Distribution	
Stage V Engine Model .....	2
Other Engine Models .....	2
Transmission .....	3
Final Drives .....	3
Body Hoist	
Stage V Engine Model .....	3
Other Engine Models .....	3
Body Capacities .....	3
Turning Dimensions .....	3
Service Refill Capacities .....	3
Tires .....	3
Standards .....	3
Dimensions .....	4
Gradeability/Speed/Rimpull .....	5
<b>Standard and Optional Equipment</b> .....	<b>6</b>



# AD45 Underground Articulated Truck Specifications

## Engine

Engine Model	Cat® C18	
Engine Power – VR Engine – ISO 14396:2002	433 kW	581 hp
Engine Power – U.S. EPA Tier 3/ EU Stage IIIA Equivalent Engine – ISO 14396:2002	433 kW	581 hp
Engine Power – Stage V Engine – ISO 14396:2002	446 kW	598 hp
Bore	145 mm	5.7 in
Stroke	183 mm	7.2 in
Displacement	18.1 L	1,104.53 in <sup>3</sup>

- Power ratings apply at a rated speed of 2,000 rpm when tested under the reference conditions for the specified standard.
- All rating conditions are based on ISO/TR14396:2002, inlet air standard conditions with a total barometric pressure of 100 kPa (29.5 in Hg), with a vapor pressure of 1 kPa (0.295 in Hg), and 25° C (77° F). Performance measured using fuel to EPA specifications in 40 CFR Part 1065 and EU specifications in Directive 97/68/EC with a density of 0.845-0.850 kg/L @ 15° C (7.05-7.09 lb/gal @ 59° F) and fuel inlet temperature 40° C (104° F).
- Minimal engine derating\* required up to 3048 m (10,000 ft) @ rated speed for Stage V engines, 2700 m (8,858 ft) for Tier 3/ Stage IIIA equivalent engines and 3505 m (11,500 ft) for Tier 2/ Stage II equivalent VR engines.
- Optional Ventilation Reduction Package available.
- Optional engine with emissions equivalent to Tier 3 and Stage IIIA is also available.
- Optional engine available that meets U.S. EPA Tier 4 Final and EU Stage V emission standards.

\*<5 %

## Operating Specifications

Nominal Payload Capacity	45 000 kg	99,208 lb
Gross Machine Mass	88 820 kg	195,815 lb
Shipping Mass (Stage V Engine Model)	43 645 kg	96,225 lb
Shipping Mass (Other Engine Models)	42 825 kg	94,415 lb

## Weights (Stage V Engine Model)

Operating Mass*	41 405 kg	91,285 lb
Front Axle	29 285 kg	64,565 lb
Rear Axle	12 120 kg	26,720 lb
Operating Mass + Rated Payload*	86 405 kg	190,495 lb
Front Axle	40 475 kg	89,235 lb
Rear Axle	45 930 kg	101,260 lb

## Weights (Other Engine Models)

Operating Mass*	40 060 kg	88,320 lb
Front Axle	27 770 kg	61,225 lb
Rear Axle	12 290 kg	27,095 lb
Operating Mass + Rated Payload*	85 060 kg	187,530 lb
Front Axle	38 715 kg	85,355 lb
Rear Axle	46 345 kg	102,175 lb

\*Calculated weight

## Weight Distribution (Stage V Engine Model)

Empty	
Front Axle	70.7%
Rear Axle	29.3%
Loaded	
Front Axle	46.8%
Rear Axle	53.2%

## Weight Distribution (Other Engine Models)

Empty	
Front Axle	69.3%
Rear Axle	30.7%
Loaded	
Front Axle	45.5%
Rear Axle	54.5%

# AD45 Underground Articulated Truck Specifications

## Transmission

Forward 1	7.0 km/h	4.4 mph
Forward 2	9.5 km/h	5.9 mph
Forward 3	12.9 km/h	8.0 mph
Forward 4	17.3 km/h	10.8 mph
Forward 5	23.5 km/h	14.6 mph
Forward 6	31.7 km/h	19.7 mph
Forward 7	42.4 km/h	26.4 mph
Reverse 1	6.8 km/h	4.2 mph
Reverse 2	9.0 km/h	5.6 mph

- Maximum travel speeds with standard 29.5 × R29 tires.

## Final Drives

Differential Ratio	3.46:1
Final Drive Ratio	5.65:1
Total Reduction Ratio	19.55:1

## Body Hoist (Stage V Engine Model)

Raise	15 Seconds
Lower	21 Seconds
Total Cycle Time	36 Seconds

## Body Hoist (Other Engine Models)

Raise	14 Seconds
Lower	21 Seconds
Total Cycle Time	35 Seconds

## Body Capacities

Dump Body 1	18.0 m <sup>3</sup>	23.6 yd <sup>3</sup>
Dump Body 2 (Standard Body)	21.3 m <sup>3</sup>	27.9 yd <sup>3</sup>
Dump Body 3	25.1 m <sup>3</sup>	32.8 yd <sup>3</sup>
Ejector Body	22.9 m <sup>3</sup>	29.9 yd <sup>3</sup>

- Heaped SAE 2:1.

## Turning Dimensions

Outside Clearance Radius*	9420 mm	371 in
Inside Clearance Radius*	5310 mm	209 in
Frame Oscillation	10°	
Articulation Angle	42.5°	

\*Clearance dimensions are for reference only.

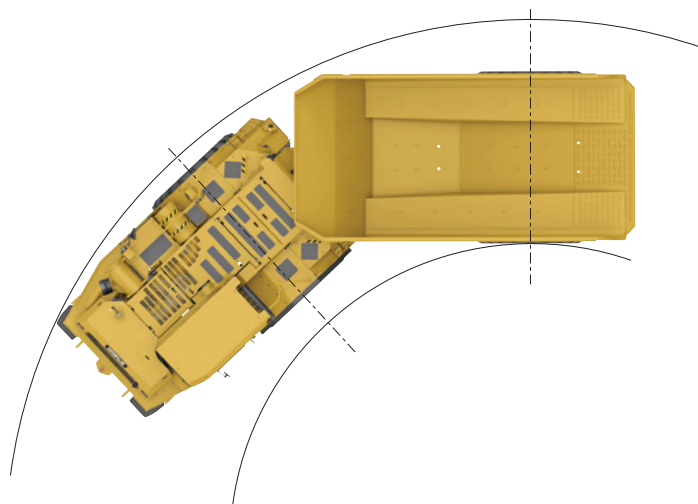

## Service Refill Capacities

Engine Crankcase with Filter	64 L	16.9 gal
Transmission	60 L	15.9 gal
Hydraulic Tank	266 L	70.3 gal
Cooling System	85 L	22.5 gal
Front Differentials and Final Drives	77 L	20.3 gal
Rear Differentials and Final Drives	83 L	21.9 gal
Fuel Tank	764 L	201.8 gal

## Tires

Tire Size	29.5 × R29
-----------	------------

## Standards

Rollover Protective Structure (ROPS)/Falling Object Guard System (FOGS) Certified Cab

# AD45 Underground Articulated Truck Specifications

## Dimensions

All dimensions are approximate.

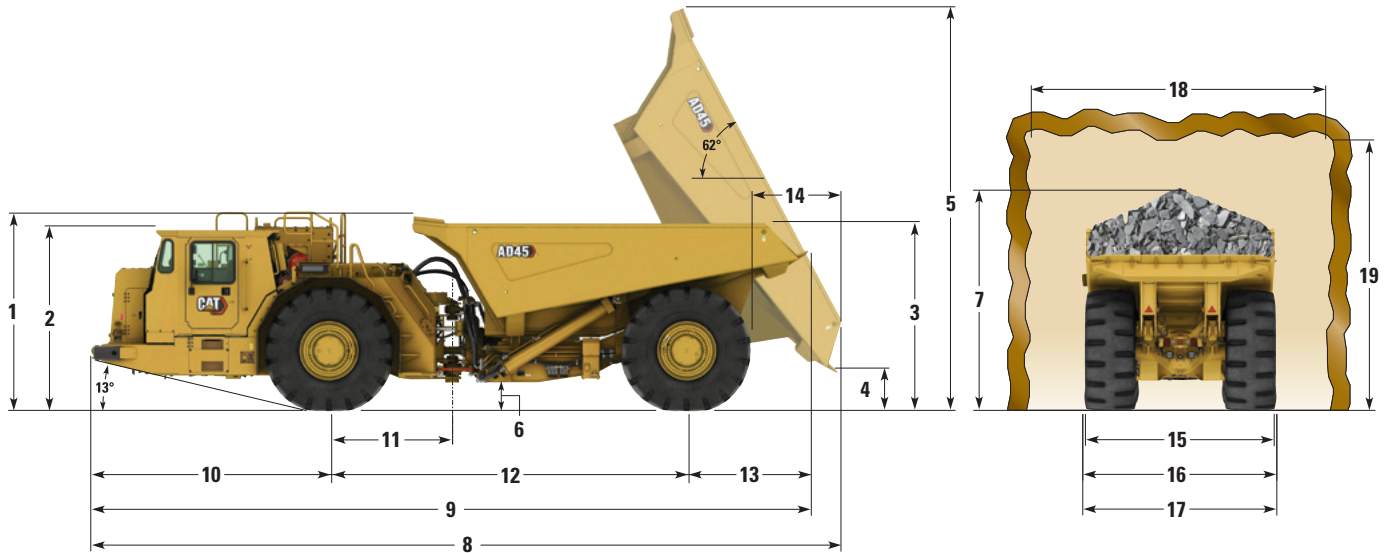

	568-7264		568-7256		568-7260		568-7265	
	Dump Body		Dump Body (STD)		Dump Body		Ejector Body	
Body Capacity	18.0 m <sup>3</sup>	23.5 yd <sup>3</sup>	21.3 m <sup>3</sup>	27.9 yd <sup>3</sup>	25.1 m <sup>3</sup>	32.8 yd <sup>3</sup>	22.9 m <sup>3</sup>	29.9 yd <sup>3</sup>
	mm	in	mm	in	mm	in	mm	in
<b>1</b> Height – Top of Empty Body	2830	111.4	3035	119.5	3181	125.2	3464	136.4
<b>2</b> Height – Top of ROPS	2820	111.0	2820	111.0	2820	111.0	2820	111.0
<b>3</b> Height – Body Loading	2720	107.1	2924	115.1	3070	120.9	3177	125.1
<b>4</b> Height – Dump Clearance**	659	25.9	659	25.9	659	25.9	961	37.8
<b>5</b> Height – Top of Raised Body	6019	237.0	6361	250.4	6607	260.1	—	—
<b>6</b> Height – Ground Clearance	441	17.4	441	17.4	441	17.4	441	17.4
<b>7</b> Height – Top of Load (SAE 2:1)	3424	134.8	3628	142.8	3834	150.9	3920	154.3
<b>8</b> Length – Maximum Overall Length	11 535	454.1	11 620	457.5	11 680	459.8	12 125	477.4
<b>9</b> Length – Overall Body Down	11 196	440.8	11 196	440.8	11 196	440.8	11 325	445.9
<b>10</b> Length – Front Axle to Front Bumper	3720	146.5	3720	146.5	3720	146.5	3720	146.5
<b>11</b> Length – Front Axle to Hitch	1920	75.6	1920	75.6	1920	75.6	1920	75.6
<b>12</b> Length – Wheel Base	5570	219.3	5570	219.3	5570	219.3	5570	219.3
<b>13</b> Length – Rear Axle to Tail	1906	75.0	1906	75.0	1906	75.0	2035	80.1
<b>14</b> Length – Rear Wheel to Raised Body	1275	50.2	1275	50.2	1275	50.2	1835	72.2
<b>15</b> Width – Overall Tire	3020	118.9	3020	118.9	3020	118.9	3020	118.9
<b>16</b> Width – Machine with Body	3020	118.9	3020	118.9	3200	126.0	3200	126.0
<b>17</b> Width – Machine without Body	3020	118.9	3020	118.9	3020	118.9	3020	118.9
<b>18</b> Recommended Clearance Width*	4500	177.2	4500	177.2	4500	177.2	4500	177.2
<b>19</b> Recommended Clearance Height*	4500	177.2	4500	177.2	4500	177.2	4500	177.2

\*Clearance dimensions are for reference only.

\*\*Measurement taken with tailgate down for ejector body.

# AD45 Underground Articulated Truck Specifications

## Gradeability/Speed/Rimpull

To determine gradeability performance: Read from gross weight down to the percent of total resistance. Total resistance equals actual percent grade plus rolling resistance as a general guide use 2% for rolling resistance in underground application or refer to the Caterpillar Performance Handbook. From the total resistance point, read horizontally to the curve with the highest obtainable gear, then down to maximum speed. Usable rimpull will depend upon traction available and weight on drive wheels.

- Typical Field Empty Weight
- ..... Loaded Weight

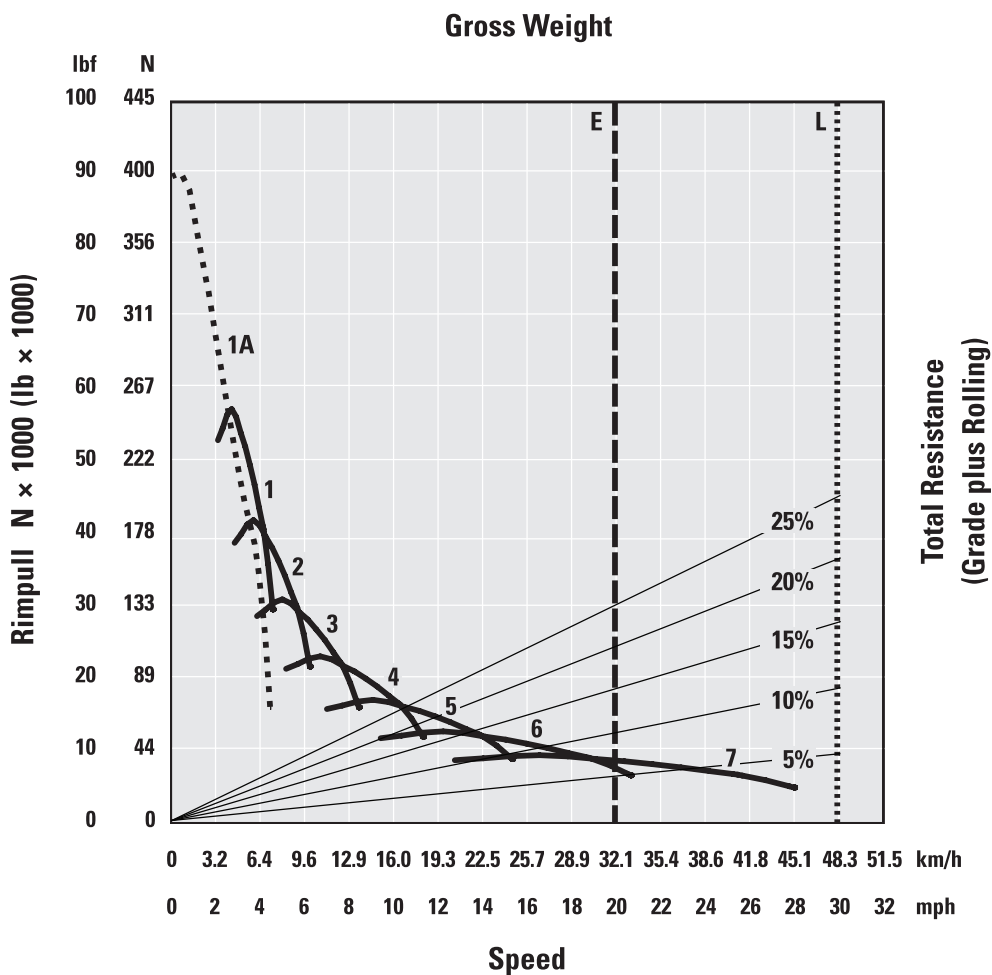

- 1A – 1st Gear Torque Converter Drive
- 1 – 1st Gear Direct Drive
- 2 – 2nd Gear Direct Drive
- 3 – 3rd Gear Direct Drive
- 4 – 4th Gear Direct Drive
- 5 – 5th Gear Direct Drive
- 6 – 6th Gear Direct Drive
- 7 – 7th Gear Direct Drive

- E – Empty 40 000 kg (88,185 lb)
- L – Loaded 85 000 kg (187,393 lb)

# AD45 Standard and Optional Equipment

## Standard and Optional Equipment

Standard and optional equipment may vary. Consult your Cat dealer for details.

	Standard	Optional		Standard	Optional
<b>POWER TRAIN</b>			<b>ELECTRICAL</b>		
Brake retarder control, automatic	✓		12V power supply in cab	✓	
Brakes:	✓		Alarm, reversing	✓	
– All wheel disc			Alternator, 95 amp	✓	
– Oil cooled			Battery disconnect switch, ground level	✓	
Control throttle shifting	✓		Battery shutdown:		✓
Engine:	✓		– Ground Level Isolation, In Cab Isolation Switch		
– Cat C18 six cylinder diesel engine			– Ground Level Isolation, Engine Shutdown Switch		
– Air-to-air aftercooler (ATAAC)			– Ground Level Isolation, In Cab Isolation, Engine Shutdown Switch		
Engine options:		✓	Circuit breaker, 80-amp	✓	
– Engine, Stage V			Diagnostic connector	✓	
– Engine, Ventilation Reduction (VR)			Disconnect switch, two post, ground level	✓	
– Equivalent to Tier 3			Electric starting, 24-volt	✓	
After-treatment options (for use with VR engine only) Diesel Particulate Filter (DPF) (flow through) filter		✓	Lights, LED:	✓	
Exhaust, turbo compartment shielding	✓		– Headlights with dimmer switch		
Fast Fill System:		✓	– Brake and tail lights		
– Coolant			– Reversing lights, automatic when reverse gear selected		
– Engine oil			– Work light, rear, cab mounted		
– Fuel (dual tanks)			Low maintenance batteries	✓	
– Hydraulic oil			Receptacle GP, auxiliary start	✓	
– Transmission oil			Starting and charging system	✓	
Four wheel drive	✓				
Fuel priming aid	✓				
Gear blockout with tray up, programmable	✓				
Ground speed limiting, programmable	✓				
Long life coolant	✓				
Parking brakes, four wheels	✓				
Park Brake Switch Engagement – Push to Apply/Pull to Apply		✓			
Precleaner, engine air intake	✓				
Radiator cap manual release	✓				
Radiator, cross flow	✓				
Secondary steering system	✓				
Transmission, automatic planetary power shift (7F/2R)	✓				
Torque converter with automatic lockup	✓				
Torque converter, high altitude, 3000 m (9,842 ft) and up		✓			

(continued on next page)

## Standard and Optional Equipment *(continued)*

Standard and optional equipment may vary. Consult your Cat dealer for details.

	Standard	Optional		Standard	Optional
<b>OPERATOR ENVIRONMENT</b>			<b>TECHNOLOGY</b>		
Cab, ROPS/FOPS certified	✓		Product Link Elite – Machine health information	✓	
Open operator station ROPS/FOPS structure	✓		Payload:		✓
Operators station ROPS/FOPS enclosed:		✓	– Truck Payload Measurement System (TPMS)		
– Air conditioning			<b>TIRES, RIMS, AND WHEELS</b>		
– Cab pressurizer and filter			Tires must be selected from the Mandatory Attachments section.	✓	
– Dome light			Choose from below:		
– Heater			– Tire, 29.5 × R29 VSNT Bridgestone		
– Radio ready compartment for radio and speakers			– Tire, 29.5 × R29 VSDL Bridgestone		
– Sun visor			Rims (set of four) – five pieces, tubeless	✓	
– Window, sliding cab door			Rim identification numbering		✓
Caterpillar Electronic Monitoring System (CEMS), dash instrument panels	✓		Spare rim, tubeless		✓
Operator Presence System	✓				
Automatic Brake Application (ABA)	✓				
Electric horns	✓				
Gauges, brake pressure	✓				
Gauges:	✓				
– Engine coolant temperature					
– Transmission coolant temperature					
– Hydraulic oil temperature					
– Fuel level					
– Speedometer					
– Tachometer					
Indicator lights:	✓				
– Alert warning light					
– Body up position warning					
– High beam					
– Residual brake pressure warning					
– Retarder application					
– Turn signal					
Low hydraulic level warning	✓				
Mirrors, rear view	✓				
Seat, suspension operator seat with retractable seat belt	✓				
Seat:		✓			
– Suspension seat Cat Comfort TLV2, vinyl					
– Suspension seat tee, mechanical					
Seat cover:		✓			
– Tee and Cat Comfort TLV2					
– Seat cover, companion					
Seat, trainer/passenger with seat belt	✓				
Steering wheel, tilt/telescopic	✓				

*(continued on next page)*

# AD45 Standard and Optional Equipment

## Standard and Optional Equipment *(continued)*

Standard and optional equipment may vary. Consult your Cat dealer for details.

	Standard	Optional		Standard	Optional
<b>OTHER STANDARD AND OPTIONAL EQUIPMENT</b>			<b>OTHER STANDARD AND OPTIONAL EQUIPMENT <i>(continued)</i></b>		
Adapters, oil sample	✓		Fuel system manual shut off tap	✓	
Alarm, tray up	✓		Front axle suspension	✓	
Ansul Fire Suppression, wet		✓	Front rubber bumpers	✓	
Axle suspension, front	✓		Handholds	✓	
Belly guards	✓		Handrails	✓	
Body dump and ejector	✓		Handrail extension		✓
– Dump, (21.3 m <sup>3</sup> /27.9 yd <sup>3</sup> )	✓		Hitch, articulated and oscillated	✓	
– Dump, (18.0 m <sup>3</sup> /23.5 yd <sup>3</sup> )		✓	Lifting lugs, frame	✓	
– Dump, (25.1 m <sup>3</sup> /32.8 yd <sup>3</sup> )		✓	Lubrication system:		✓
– Ejector, (22.9 m <sup>3</sup> /30.0 yd <sup>3</sup> )		✓	– Automatic, dump or ejector body		
Body liners, impact and/or wear		✓	– Centralized, ejector body		
Body wear plate, external		✓	Mine transfer		✓
Bumpers, front, rubber	✓		Operation and Maintenance Manual – English and other applicable local languages to select	✓	
Camera:		✓	Reflective tapes		✓
– Color rear facing			Scheduled Oil Sampling (S·O·S <sup>SM</sup> ) port:	✓	
– Color loading			– Coolant		
Cover, anti vandalism for shipping		✓	– Engine oil		
Cap, radiator, manual release	✓		– Hydraulic oil		
Catalytic exhaust purifier/muffler group	✓		– Transmission oil		
Centralized lubrication points	✓		Service tools		✓
Covers, exhaust	✓		Swing out radiator grill	✓	
Dual fuel tanks	✓		Tow pin, front and rear	✓	
Engine and transmission belly guards	✓				
Fenders, front, rear flaps	✓				
Firewall	✓				
Fluids:		✓			
– Arctic fuel					
– Arctic coolant					

For more complete information on Cat products, dealer services, and industry solutions, visit us on the web at [www.cat.com](http://www.cat.com)

AEXQ3473-01 (11-2024)  
(Global)

© 2024 Caterpillar  
All rights reserved

Materials and specifications are subject to change without notice. Featured machines in photos may include additional equipment. See your Cat dealer for available options.

CAT, CATERPILLAR, LET'S DO THE WORK, their respective logos, "Caterpillar Corporate Yellow," the "Power Edge" and Cat "Modern Hex" trade dress as well as corporate and product identity used herein, are trademarks of Caterpillar and may not be used without permission.

