

# Operation and Maintenance Manual

---

**5006A-E23TA, 5008A-E30TA, 5008C-  
E30TA, and 5008AC-E30TA Industrial  
Engines**

---

## Important Safety Information

Most accidents that involve product operation, maintenance and repair are caused by failure to observe basic safety rules or precautions. An accident can often be avoided by recognizing potentially hazardous situations before an accident occurs. A person must be alert to potential hazards. This person should also have the necessary training, skills and tools to perform these functions correctly.

**Incorrect operation, lubrication, maintenance or repair of this product can be dangerous and could result in injury or death.**

**Do not operate or perform any lubrication, maintenance or repair on this product, until you have read and understood the operation, lubrication, maintenance and repair information.**

Safety precautions and warnings are provided in this manual and on the product. If these hazard warnings are not heeded, bodily injury or death could occur to you or to other persons.

The hazards are identified by the "Safety Alert Symbol" and followed by a "Signal Word" such as "DANGER", "WARNING" or "CAUTION". The Safety Alert "WARNING" label is shown below.



The meaning of this safety alert symbol is as follows:

**Attention! Become Alert! Your Safety is Involved.**

The message that appears under the warning explains the hazard and can be either written or pictorially presented.

Operations that may cause product damage are identified by "NOTICE" labels on the product and in this publication.

**Perkins cannot anticipate every possible circumstance that might involve a potential hazard. The warnings in this publication and on the product are, therefore, not all inclusive. You must not use this product in any manner different from that considered by this manual without first satisfying yourself that you have considered all safety rules and precautions applicable to the operation of the product in the location of use, including site-specific rules and precautions applicable to the worksite. If a tool, procedure, work method or operating technique that is not specifically recommended by Perkins is used, you must satisfy yourself that it is safe for you and for others. You should also ensure that you are authorized to perform this work, and that the product will not be damaged or become unsafe by the operation, lubrication, maintenance or repair procedures that you intend to use.**

The information, specifications, and illustrations in this publication are on the basis of information that was available at the time that the publication was written. The specifications, torques, pressures, measurements, adjustments, illustrations, and other items can change at any time. These changes can affect the service that is given to the product. Obtain the complete and most current information before you start any job. Perkins dealers or Perkins distributors have the most current information available.



**When replacement parts are required for this product Perkins recommends using Perkins replacement parts.**

**Failure to heed this warning can lead to premature failures, product damage, personal injury or death.**

**In the United States, the maintenance, replacement, or repair of the emission control devices and systems may be performed by any repair establishment or individual of the owner's choosing.**

## Table of Contents

Foreword .....	4
----------------	---

### Safety Section

Safety Messages .....	6
Additional Messages .....	12
General Hazard Information.....	12
Burn Prevention.....	16
Fire Prevention and Explosion Prevention.....	17
Crushing Prevention and Cutting Prevention..	19
Mounting and Dismounting .....	19
Before Starting Engine .....	19
Engine Starting.....	20
Engine Stopping .....	20
Electrical System.....	20
Engine Electronics.....	21

### Product Information Section

Model Views .....	22
Product Identification Information .....	31

### Operation Section

Lifting and Storage .....	33
Features and Controls.....	38
Engine Diagnostics .....	48
Engine Starting.....	49
Engine Operation .....	52
Engine Stopping .....	53
Cold Weather Operation .....	54

### Maintenance Section

Refill Capacities.....	56
Maintenance Recommendations .....	62
Maintenance Interval Schedule (50Hz Engines in Standby Applications).....	63
Maintenance Interval Schedule (Engines in Prime Power Applications) .....	65
Maintenance Interval Schedule (Engines in Base Load Applications).....	67
Maintenance Interval Schedule (60Hz Engines in Standby Applications).....	69

### Warranty Section

Warranty Information.....	121
---------------------------	-----

### Index Section

Index.....	122
------------	-----

## Foreword

### California Proposition 65 Warning

**Diesel engine exhaust and some of its constituents are known to the State of California to cause cancer, birth defects, and other reproductive harm.**



**WARNING – This product can expose you to chemicals including ethylene glycol, which is known to the State of California to cause birth defects or other reproductive harm. For more information go to:**

**[www.P65Warnings.ca.gov](http://www.P65Warnings.ca.gov)**

**Do not ingest this chemical. Wash hands after handling to avoid incidental ingestion.**



**WARNING – This product can expose you to chemicals including lead and lead compounds, which are known to the State of California to cause cancer, birth defects, or other reproductive harm. For more information go to:**

**[www.P65Warnings.ca.gov](http://www.P65Warnings.ca.gov)**

**Wash hands after handling components that may contain lead.**

### Literature Information

This manual contains safety, operation instructions, lubrication, and maintenance information. This manual should be stored in or near the engine area in a literature holder or literature storage area. Read, study, and keep the manual with the literature and engine information.

English is the primary language for all Perkins publications. The English used facilitates translation and consistency.

Some photographs or illustrations in this manual show details or attachments that may be different from your engine. Guards and covers may have been removed for illustrative purposes. Continuing improvement and advancement of product design may have caused changes to your engine which are not included in this manual. Whenever a question arises regarding your engine, or this manual, please consult with your Perkins dealer or your Perkins distributor for the latest available information.

### Safety

This safety section lists basic safety precautions. In addition, this section identifies hazardous, warning situations. Read and understand the basic precautions listed in the safety section before operating or performing lubrication, maintenance, and repair on this product.

### Operation

Operating techniques outlined in this manual are basic. The operating techniques assist with developing the skills and techniques required to operate the engine more efficiently and economically. Skill and techniques develop as the operator gains knowledge of the engine and the capabilities of the engine.

The operation section is a reference for operators. Photographs and illustrations guide the operator through procedures of inspecting, starting, operating, and stopping the engine. This section also includes a discussion of electronic diagnostic information.

### Maintenance

The maintenance section is a guide to engine care. The illustrated, step-by-step instructions are grouped by service hours and/or calendar time maintenance intervals. Items in the maintenance schedule are referenced to detailed instructions that follow.

Recommended service should be performed at the appropriate intervals as indicated in the Maintenance Interval Schedule. The actual operating environment of the engine also governs the Maintenance Interval Schedule. Therefore, under severe, dusty, wet, or freezing cold operating conditions, more frequent lubrication, and maintenance than is specified in the Maintenance Interval Schedule may be necessary.

The maintenance schedule items are organized for a preventive maintenance management program. If the preventive maintenance program is followed, a periodic tune-up is not required. The implementation of a preventive maintenance management program should minimize operating costs through cost avoidances resulting from reductions in unscheduled downtime and failures.

## **Maintenance Intervals**

Perform maintenance on items at multiples of the original requirement. Each level and/or individual items in each level should be shifted ahead or back depending upon your specific maintenance practices, operation, and application. Perkins recommends that the maintenance schedules be reproduced and displayed near the engine as a convenient reminder. Perkins also recommends that a maintenance record be maintained as part of the permanent record of the engine.

Your authorized Perkins dealer or your Perkins distributor can assist you in adjusting your maintenance schedule to meet the needs of your operating environment.

## **Overhaul**

Major engine overhaul details are not covered in the Operation and Maintenance Manual except for the interval and the maintenance items in that interval. Major repairs are best left to trained personnel or an authorized Perkins distributor or dealer. Your Perkins dealer or your Perkins distributor offers various options regarding overhaul programs. If you experience a major engine failure, there are also numerous after failure overhaul options available. Consult with your Perkins dealer or your Perkins distributor for information regarding these options.

# Safety Section

i10195728

## Safety Messages

There may be several specific warning signs on your engine. The exact location and a description of the warning signs are reviewed in this section. Safety labels are ISO or ANSI standard compliant depending on geographic location. Become familiar with all warning signs.

Ensure that all the warning signs are legible. Clean the warning signs or replace the warning signs if the words cannot be read or if the illustrations are not visible. Use a cloth, water, and soap to clean the warning signs. Do not use solvents, gasoline, or other harsh chemicals. Solvents, gasoline, or harsh chemicals could loosen the adhesive that secures the warning signs. The warning signs that are loosened could drop off the engine.

Replace any warning sign that is damaged or missing. If a warning sign is attached to a part of the engine that is replaced, install a new warning sign on the replacement part. Your Perkins distributor can provide new warning signs.

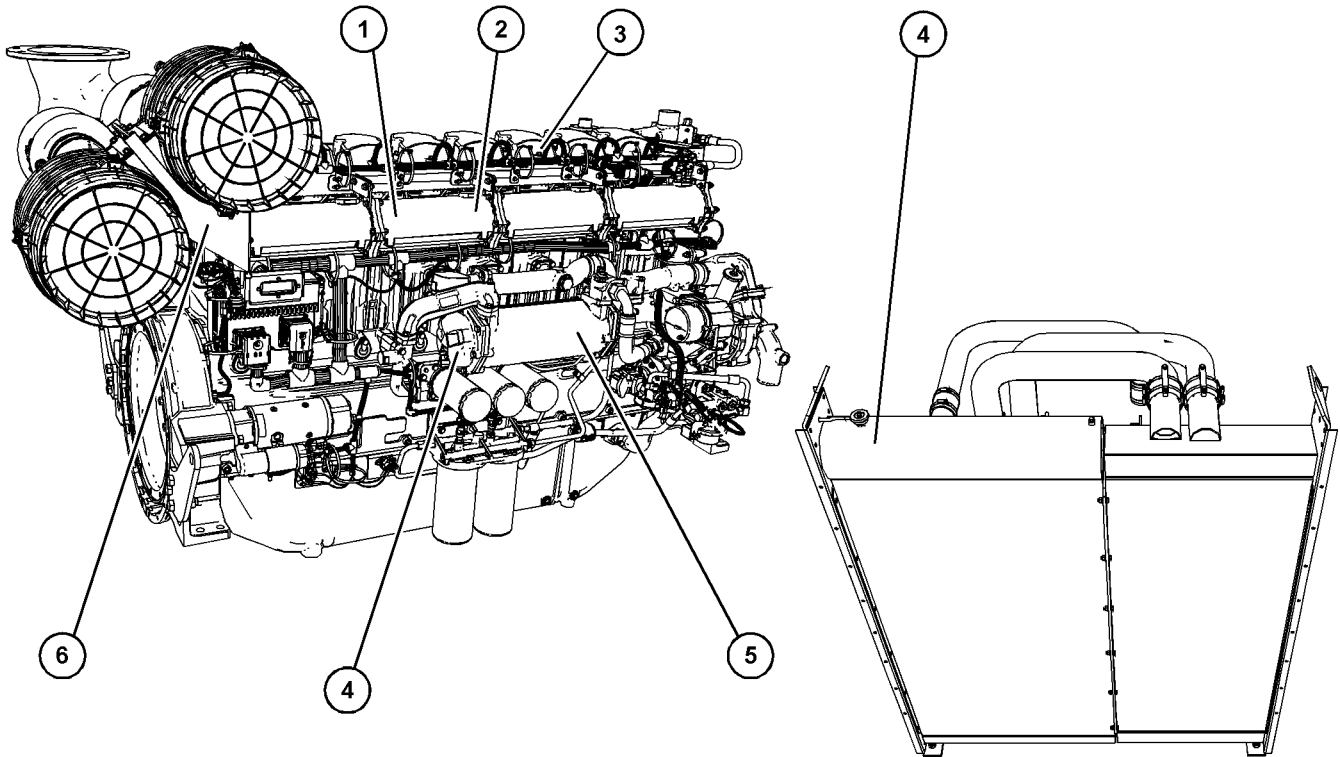

Illustration 1

g06642298

Typical example of an earlier engine

(1) Universal warning label locations  
(2) Do not step label location

(3) Electrocution danger label location  
(4) Hot fluid under pressure label locations

(5) Hot surface label location  
(6) Ether warning label location

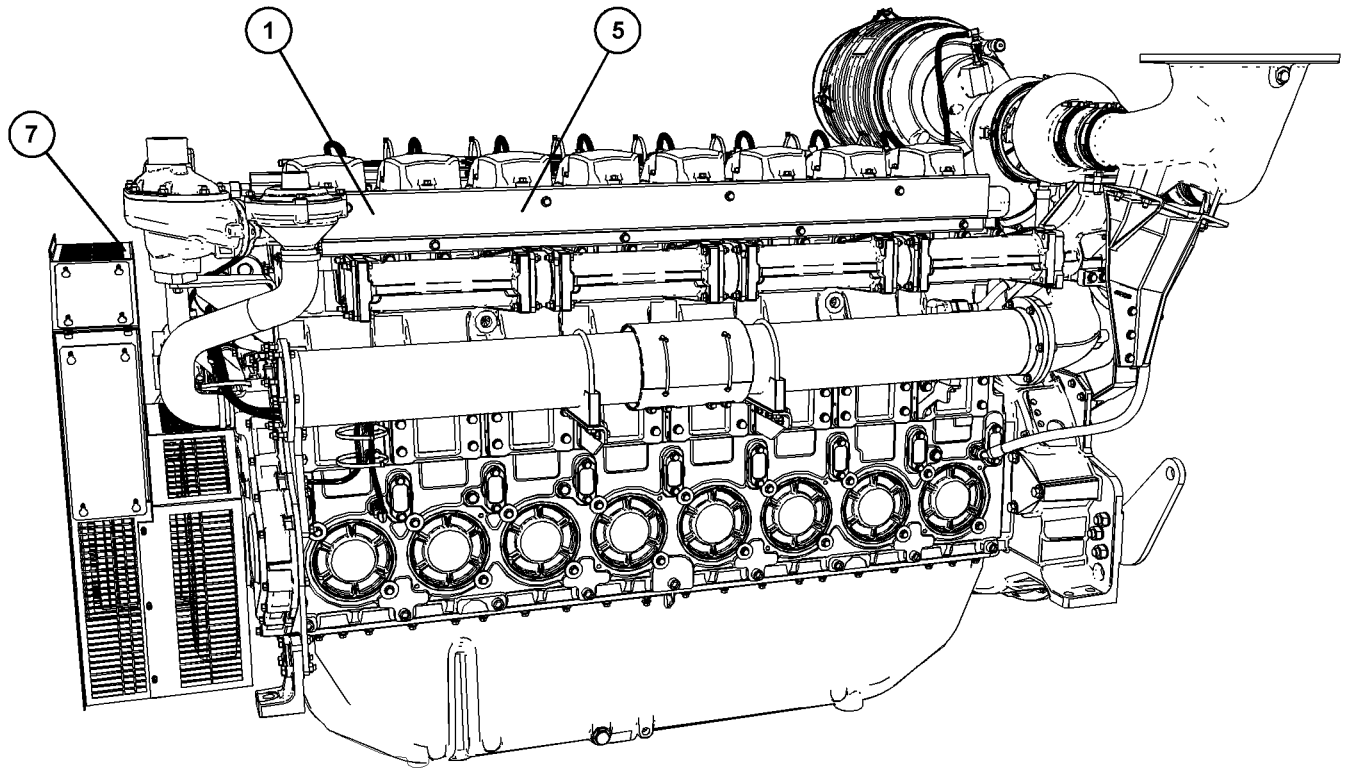

Illustration 2

g06645122

Typical example of an earlier engine

- (1) Universal warning label locations
- (5) Hot surface label location
- (7) Rotating shaft hand crush hazard label location

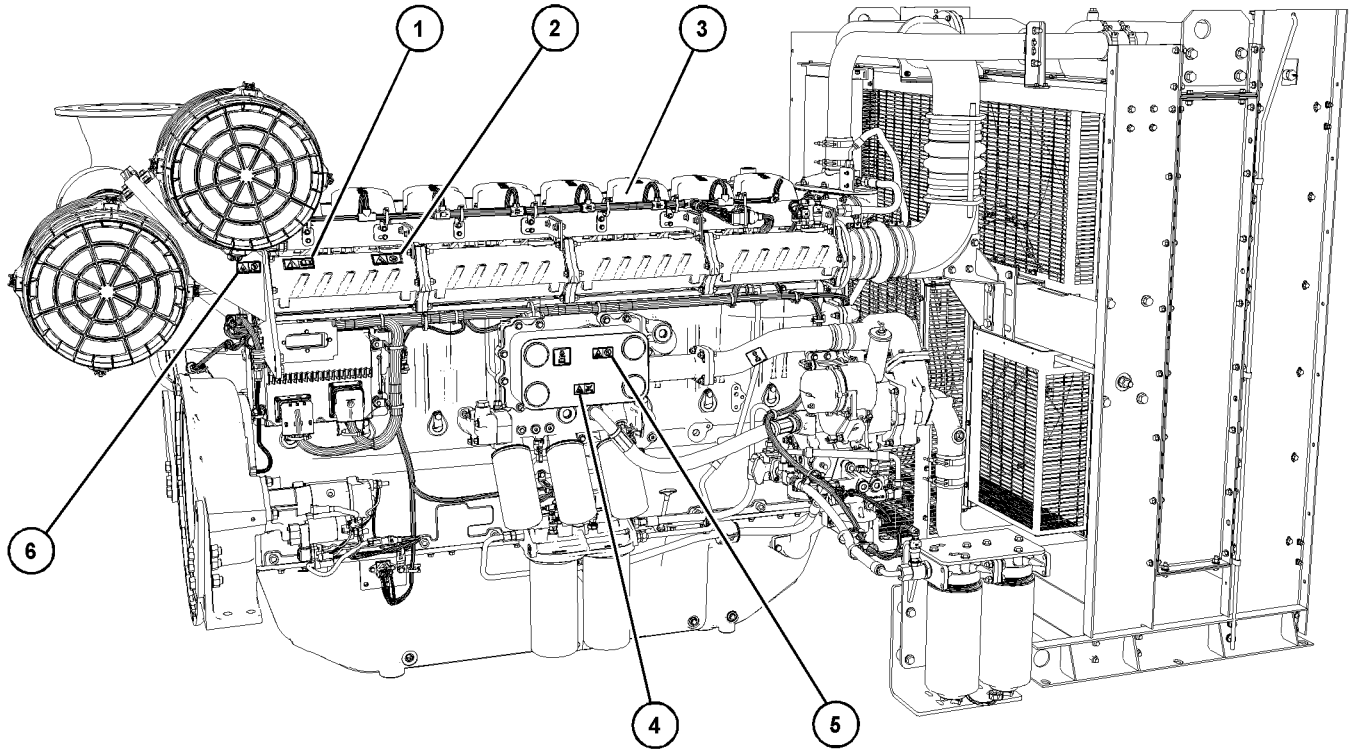

Illustration 3

g07583017

Typical example of a later engine

(1) Universal warning label locations  
(2) Do not step label location

(3) Electrocution danger label location  
(4) Hot fluid under pressure label locations

(5) Hot surface label location  
(6) Ether warning label location



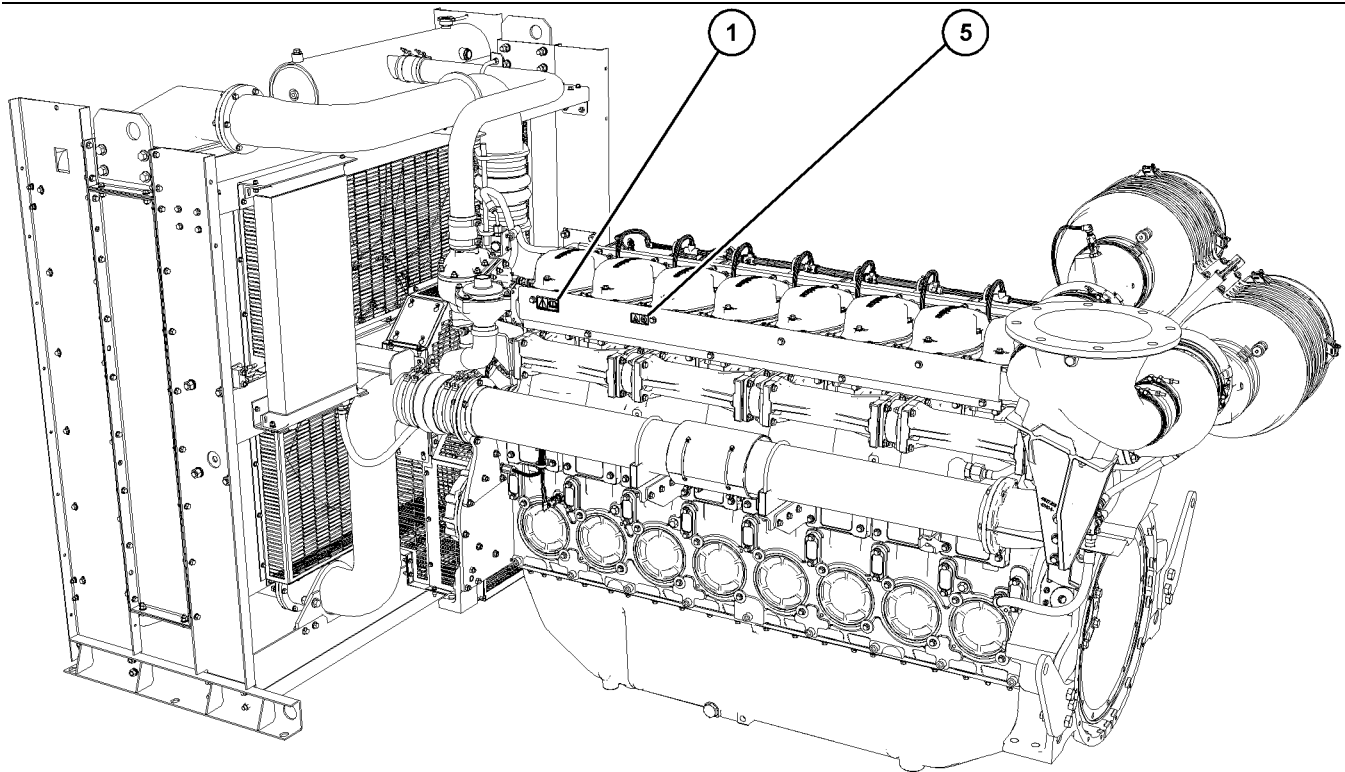

Illustration 4

g07583027

Typical example of a later engine

(1) Universal warning label locations

(5) Hot surface label location

## 1 Universal Warning

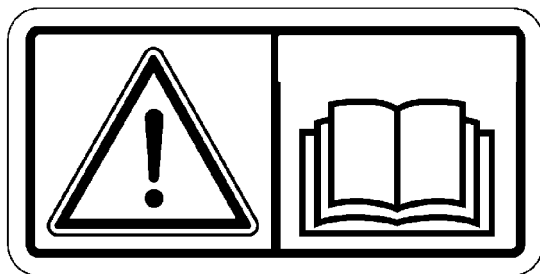

Illustration 5

g06019365

Universal Warning label

### **WARNING**

**Do not operate or work on this equipment unless you have read and understand the instructions and warnings in the Operation and Maintenance Manuals. Failure to follow the instructions or heed the warnings could result in serious injury or death.**

The universal warning label (1) is installed on the intake manifold.

### 2 Do Not Step

Do not step safety message (2) can be found on the intake manifold.

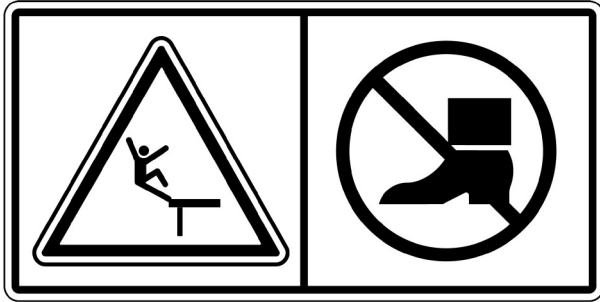

Illustration 6

g01393287

**⚠ WARNING**

Do not use this surface as a step or platform. This surface may not support additional weight or may be slippery. Serious injury or death could occur from a fall.

### 3 Electrocutation

Electrocutation Danger safety message (3) is on the valve mechanism cover of cylinder 3.

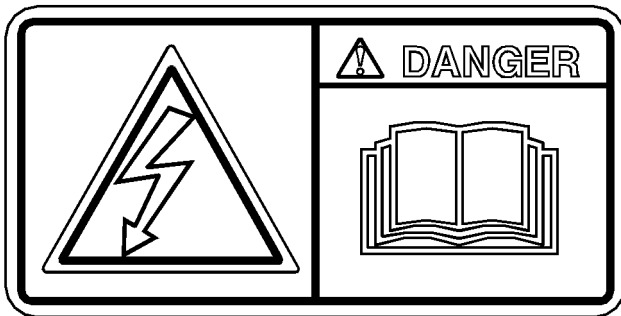

Illustration 7

g06644822

**⚠ DANGER**

**DANGER: Shock/Electrocutation Hazard-Do not operate this equipment or work on this equipment unless you have read and understand the instructions and warnings in the Operation and Maintenance Manual. Failure to follow the instructions or heed the warnings will result in serious injury or death.**

### 4 Hot Fluid Under Pressure



Illustration 8

g01371640

**⚠ WARNING**

Pressurized system! Hot coolant can cause serious burns, injury or death. To open the cooling system filler cap, stop the engine and wait until the cooling system components are cool. Loosen the cooling system pressure cap slowly in order to relieve the pressure. Read and understand the Operation and Maintenance Manual before performing any cooling system maintenance.

The hot fluids under pressure labels (4) have two positions. One label is on the end cover of the oil cooler. Perkins recommends that the other hot fluid under pressure label is installed on the radiator, next to the coolant filler cap.

### 5 Hot Surface



Illustration 9

g01372256

**! WARNING**

Hot parts or hot components can cause burns or personal injury. Do not allow hot parts or components to contact your skin. Use protective clothing or protective equipment to protect your skin.

The hot surface warning labels (5) can be found in two locations. The oil cooler and heat shield of the coolant rail.

### 6 Ether Warning



Illustration 10

g01372254

**! WARNING**

Do not use aerosol types of starting aids such as ether. Such use could result in an explosion and personal injury.

Either warning label (6) is on the support bracket for the air cleaners.

### 7 Rotating Shaft Hand Crush Hazard

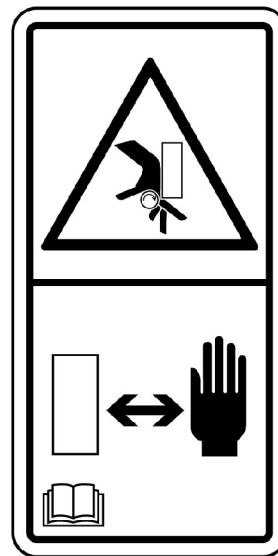

Illustration 11

g02781437

**! WARNING**

Rotating shaft pinch hazard. The shaft under this cover is rotating anytime the engine is running. Contact with a rotating shaft could cause injury or death. Keep hands away.

The rotating shaft hand crush hazard label (7) is on the cover of the crankshaft vibration damper.

i09763589

## Additional Messages

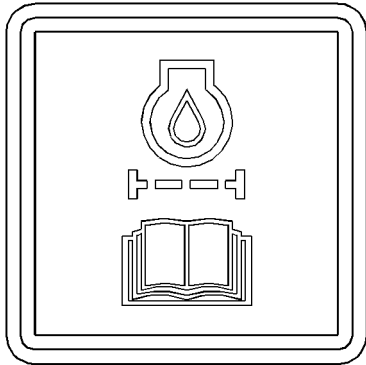

Illustration 12

g06249496

Typical example

Label (1) will be installed on the engine oil cooler. A special starting procedure may be required. Refer to this Operation and Maintenance Manual, Before Starting Engine for the correct procedure.

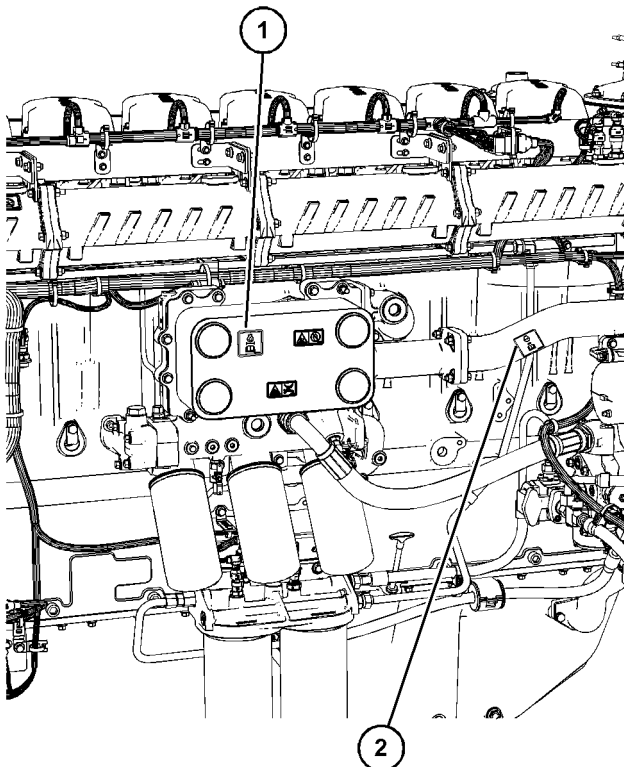

Illustration 13

g07583068

Typical example of a later engine

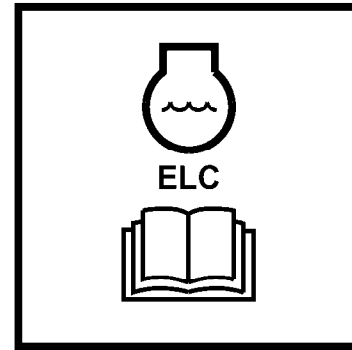

Illustration 14

g00955999

Typical example

Label (2) will be installed on coolant pipe next to the oil filler. Refer to this Operation and Maintenance Manual, Fluid Recommendations (General Coolant Information) for information.

i09915008

## General Hazard Information

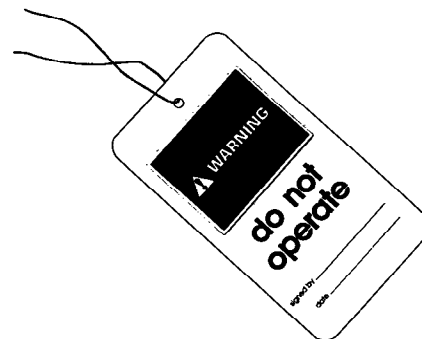

Illustration 15

g00104545

Attach a "Do Not Operate" warning tag or a similar warning tag to the start switch or to the controls before the engine is serviced or before the engine is repaired. Attach the warning tags to the engine and to each operator control station. When appropriate, disconnect the starting controls.

Do not allow unauthorized personnel on the engine, or around the engine when the engine is being serviced.

- Tampering with the engine installation or tampering with the OEM supplied wiring can be dangerous. Personal injury, death and/or engine damage could result.

- Vent the engine exhaust to the outside when the engine is operated in an enclosed area.
- Wear a hard hat, protective glasses, and other protective equipment, as required.
- When working around an engine, the engine must not be in operation. You may only be near a running engine to carry out maintenance procedures that require the engine to be in operation.
- Do not wear loose clothing or jewelry that can snag on controls or on other parts of the engine.
- Ensure that all protective guards and all covers are secured in place on the engine.
- Never put maintenance fluids into glass containers. Glass containers can break.
- Use all cleaning solutions with care.
- Report all necessary repairs.

Unless other instructions are provided, perform the maintenance under the following conditions:

- The engine is stopped. Ensure that the engine cannot be started.
- The protective locks or the controls are in the applied position.
- Disconnect the batteries when maintenance is performed or when the electrical system is serviced. Disconnect the battery ground leads. Tape the leads to help prevent sparks. If equipped, allow the diesel exhaust fluid to be purged before disconnecting the battery.
- If equipped, disconnect the connectors for the unit injectors that are on the valve cover base. This action will help prevent personal injury from the high voltage to the unit injectors. Do not come in contact with the unit injector terminals while the engine is operating.
- Do not attempt any repairs or any adjustments to the engine while the engine is operating.
- Do not attempt any repairs that are not understood. Use the proper tools. Replace any equipment that is damaged or repair the equipment.
- For initial start-up of a new engine or for starting an engine that has been serviced, make provisions to stop the engine if an overspeed occurs. The stopping of the engine may be accomplished by shutting off the fuel supply and/or the air supply to the engine. Ensure that only the fuel supply line is shut off. Ensure that the fuel return line is open.

- Start the engine from the operators station (cab). Never short across the starting motor terminals or the batteries. This action could bypass the engine neutral start system and/or the electrical system could be damaged.

### WARNING

**Engine exhaust contains products of combustion which may be harmful to your health. Always start and operate the engine in a well ventilated area and, if in an enclosed area, vent the exhaust to the outside.**

Cautionously remove the following parts. To help prevent spraying or splashing of pressurized fluids, hold a rag over the part that is being removed.

- Filler caps
- Grease fittings
- Pressure taps
- Breathers
- Drain plugs

Use caution when cover plates are removed. Gradually loosen, but do not remove the last two bolts or nuts that are at opposite ends of the cover plate or the device. Before removing the last two bolts or nuts, pry the cover loose to relieve any spring pressure or other pressure.

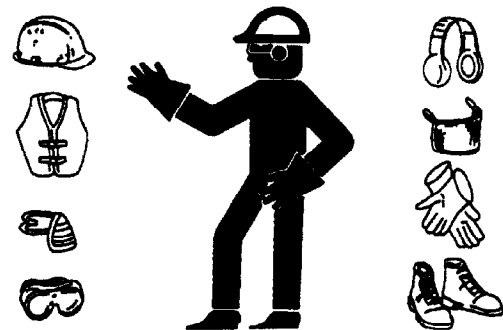

Illustration 16

g00702020

- Wear a hard hat, protective glasses, and other protective equipment, as required.
- Perkins recommend that you do not stand next to an exposed running engine unless it is necessary when carrying out daily checks or maintenance procedures. The appropriate Personal Protective Equipment (PPE) must be worn when standing next to an exposed running engine.

Safety Section  
General Hazard Information

- Do not wear loose clothing or jewelry that can snag on controls or on other parts of the engine.
- Ensure that all protective guards and all covers are secured in place on the engine.
- Never put maintenance fluids into glass containers. Glass containers can break.
- Use all cleaning solutions with care.
- Report all necessary repairs.

**Unless other instructions are provided, perform the maintenance under the following conditions:**

- The engine is stopped. Ensure that the engine cannot be started.
- Disconnect the batteries when maintenance is performed or when the electrical system is serviced. Disconnect the battery ground leads. Tape the leads to help prevent sparks.
- Do not attempt any repairs that are not understood. Use the proper tools. Replace any equipment that is damaged or repair the equipment.

## Pressurized Air and Water

Pressurized air and/or water can cause debris and/or hot water to be blown out. This action could result in personal injury.

When pressurized air and/or pressurized water is used for cleaning, wear protective clothing, protective shoes, and eye protection. Eye protection includes goggles or a protective face shield.

The maximum air pressure for cleaning purposes must be below 205 kPa (30 psi). The maximum water pressure for cleaning purposes must be below 275 kPa (40 psi).

## Fluid Penetration

Pressure can be trapped in the hydraulic circuit long after the engine has been stopped. The pressure can cause hydraulic fluid or items such as pipe plugs to escape rapidly if the pressure is not relieved correctly.

Do not remove any hydraulic components or parts until pressure has been relieved or personal injury may occur. Do not disassemble any hydraulic components or parts until pressure has been relieved or personal injury may occur. Refer to the OEM information for any procedures that are required to relieve the hydraulic pressure.

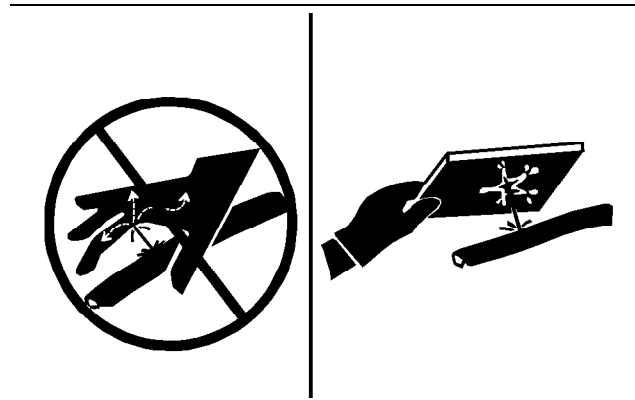

Illustration 17

g00687600

Always use a board or cardboard when you check for a leak. Leaking fluid that is under pressure can penetrate body tissue. Fluid penetration can cause serious injury and possible death. A pin hole leak can cause severe injury. If fluid is injected into your skin, you must get treatment immediately. Seek treatment from a doctor that is familiar with this type of injury.

## Containing Fluid Spillage

Care must be taken to ensure that fluids are contained during performance of inspection, maintenance, testing, adjusting, and repair of the product. Be prepared to collect the fluid with suitable containers before opening any compartment or disassembling any component containing fluids.

Dispose of all fluids according to local regulations and mandates.

## Static Electricity Hazard when Fueling with Ultra-low Sulfur Diesel Fuel

The removal of sulfur and other compounds in ultra-low sulfur diesel fuel (ULSD fuel) decreases the conductivity of ULSD and increases the ability of ULSD to store static charge. Refineries may have treated the fuel with a static dissipating additive. Many factors can reduce the effectiveness of the additive over time. Static charges can build up in ULSD fuel while the fuel is flowing through fuel delivery systems. Static electricity discharge when combustible vapors are present could result in a fire or explosion. Ensure that the entire system used to refuel your machine (fuel supply tank, transfer pump, transfer hose, nozzle, and others) is properly grounded and bonded. Consult with your fuel or fuel system supplier to ensure that the delivery system complies with fueling standards for proper grounding and bonding.

**⚠ WARNING**

**Avoid static electricity risk when fueling. Ultra-low sulfur diesel fuel (ULSD fuel) poses a greater static ignition hazard than earlier diesel formulations with a higher sulfur contents. Avoid death or serious injury from fire or explosion. Consult with your fuel or fuel system supplier to ensure the delivery system is in compliance with fueling standards for proper grounding and bonding practices.**

**Inhalation**

Illustration 18

g00702022

**Exhaust**

Use caution. Exhaust fumes can be hazardous to health. If you operate the equipment in an enclosed area, adequate ventilation is necessary.

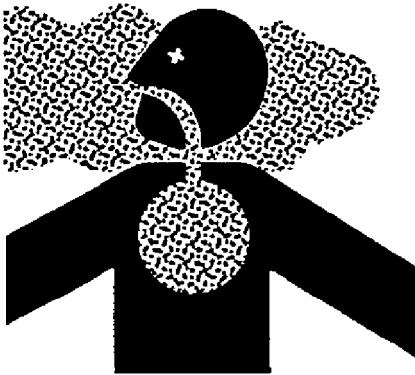
**Hexavalent Chromium**

Perkins equipment and replacement parts comply with applicable regulations and requirements where originally sold. Perkins recommends the use of only genuine Perkins replacement parts.

Hexavalent chromium has occasionally been detected on exhaust and heat shield systems on Perkins engines. Although laboratory testing is the only accurate way to know if hexavalent chromium is, in fact, present, the presence of a yellow deposit in areas of high heat (for example, exhaust system components or exhaust insulation) may be an indication of the presence of hexavalent chromium.

Use caution if you suspect the presence of hexavalent chromium. Avoid skin contact when handling items that you suspect may contain hexavalent chromium, and avoid inhalation of any dust in the suspect area. Inhalation of, or skin contact with, hexavalent chromium dust may be hazardous to your health.

If such yellow deposits are found on the engine, engine component parts, or associated equipment or packages, Perkins recommends following local health and safety regulations and guidelines, utilizing good hygiene, and adhering to safe work practices when handling the equipment or parts. Perkins also recommends the following:

- Wear appropriate Personal Protective Equipment (PPE)
- Wash your hands and face with soap and water prior to eating, drinking, or smoking, and also during rest room breaks, to prevent ingestion of any yellow powder
- Never use compressed air for cleaning areas suspected of containing hexavalent chromium
- Avoid brushing, grinding, or cutting materials suspected of containing hexavalent chromium
- Obey environmental regulations for the disposal of all materials that may contain or have come into contact with hexavalent chromium
- Stay away from areas that might have hexavalent chromium particles in the air.

**Asbestos Information**

Perkins equipment and replacement parts that are shipped from Perkins engine company limited are asbestos free. Perkins recommends the use of only genuine Perkins replacement parts. Use the following guidelines when you handle any replacement parts that contain asbestos or when you handle asbestos debris.

Use caution. Avoid inhaling dust that might be generated when you handle components that contain asbestos fibers. Inhaling this dust can be hazardous to your health. The components that may contain asbestos fibers are brake pads, brake bands, lining material, clutch plates, and some gaskets. The asbestos that is used in these components is usually bound in a resin or sealed in some way. Normal handling is not hazardous unless airborne dust that contains asbestos is generated.

If dust that may contain asbestos is present, there are several guidelines that should be followed:

- Never use compressed air for cleaning.
- Avoid brushing materials that contain asbestos.
- Avoid grinding materials that contain asbestos.
- Use a wet method to clean up asbestos materials.
- A vacuum cleaner that is equipped with a high efficiency particulate air filter (HEPA) can also be used.

- Use exhaust ventilation on permanent machining jobs.
- Wear an approved respirator if there is no other way to control the dust.
- Comply with applicable rules and regulations for the work place. In the United States, use Occupational Safety and Health Administration (OSHA) requirements. These OSHA requirements can be found in "29 CFR 1910.1001".
- Obey environmental regulations for the disposal of asbestos.
- Stay away from areas that might have asbestos particles in the air.

## Dispose of Waste Properly

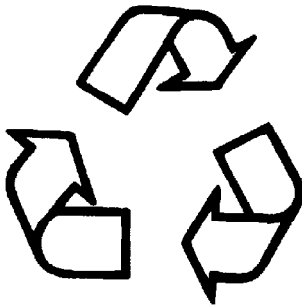

Illustration 19

g00706404

Improperly disposing of waste can threaten the environment. Potentially harmful fluids should be disposed of according to local regulations.

Always use leakproof containers when you drain fluids. Do not pour waste onto the ground, down a drain, or into any source of water.

i07390117

## Burn Prevention

### Coolant

When the engine is at operating temperature, the engine coolant is hot. The coolant is also under pressure. The radiator and all lines to the heaters or to the engine contain hot coolant. Any contact with hot coolant or with steam can cause severe burns. Allow cooling system components to cool before the cooling system is drained.

Check that the coolant level after the engine has stopped and the engine has been allowed to cool. Ensure that the filler cap is cool before removing the filler cap. The filler cap must be cool enough to touch with a bare hand. Remove the filler cap slowly to relieve pressure. Refer to this Operation and Maintenance Manual, Cooling System Coolant Level - Check for more information.

Cooling system conditioner contains alkali. Alkali can cause personal injury. Do not allow alkali to contact the skin, the eyes, or the mouth.

### Oils

Skin may be irritated following repeated or prolonged exposure to mineral and synthetic base oils. Refer to your suppliers Material Safety Data Sheets for detailed information. Hot oil and lubricating components can cause personal injury. Do not allow hot oil to contact the skin. Appropriate personal protective equipment should be used.

### Viton Seals

#### WARNING

**If Viton is burned, a product of this burnt material is an acid which is hazardous. Do not allow burnt material to come into contact with the skin or with the eyes. Use the appropriate set of Personal Protective Equipment to protect your skin and eyes. Failure to follow the instructions or heed the warning could result in serious injury or death.**

If there is need to come into contact with components which have been burnt, ensure that the precautions which follow are used:

- Ensure that the components have cooled.
- Use Neoprene gloves and discard the gloves safely after use.
- Wash the area with calcium hydroxide solution and then with clean water.
- Disposal of components and gloves which are contaminated must be in accordance with local regulations.



If there is contamination of the skin or eyes, wash the affected area with a continuous supply of clean water or with calcium hydroxide solution. Wash the area effected for 15 to 60 minutes and obtain immediate medical attention.

## Diesel Fuel

Diesel may be irritating to the eyes, respiratory system, and skin. Prolonged exposure to diesel may cause various skin conditions. Appropriate personal protective equipment should be used. Refer to supplier Material safety Data sheets for detailed information.

## Batteries

The liquid in a battery is an electrolyte. Electrolyte is an acid that can cause personal injury. Do not allow electrolyte to contact the skin or the eyes.

Do not smoke whilst checking the battery electrolyte levels. Batteries give off flammable fumes which can explode.

Always wear protective glasses when you work with batteries. Wash hands after touching batteries. The use of gloves is recommended.

i06545894

## Fire Prevention and Explosion Prevention



Illustration 20

g00704000

All fuels, most lubricants, and some coolant mixtures are flammable.

Flammable fluids that are leaking or spilled onto hot surfaces or onto electrical components can cause a fire. Fire may cause personal injury and property damage.

After the emergency stop button is operated, ensure that you allow 15 minutes, before the engine covers are removed.

Determine whether the engine will be operated in an environment that allows combustible gases to be drawn into the air inlet system. These gases could cause the engine to overspeed. Personal injury, property damage, or engine damage could result.

If the application involves the presence of combustible gases, consult your Perkins dealer and/or your Perkins distributor for additional information about suitable protection devices.

Remove all flammable combustible materials or conductive materials such as fuel, oil, and debris from the engine. Do not allow any flammable combustible materials or conductive materials to accumulate on the engine.

Store fuels and lubricants in correctly marked containers away from unauthorized persons. Store oily rags and any flammable materials in protective containers. Do not smoke in areas that are used for storing flammable materials.

Do not expose the engine to any flame.

Exhaust shields (if equipped) protect hot exhaust components from oil or fuel spray if there was a line, a tube, or a seal failure. Exhaust shields must be installed correctly.

Do not carry out any work on the fuel lines or tanks that could ignite residual fuel. Grinding, welding, cutting, chiseling, and sawing have the potential to create a source of ignition must be avoided.

Do not weld on lines or tanks that contain flammable fluids. Do not flame cut lines or tanks that contain flammable fluid. Clean any such lines or tanks thoroughly with a nonflammable solvent prior to welding or flame cutting.

Wiring must be kept in good condition. Ensure that all electrical wires are correctly installed and securely attached. Check all electrical wires daily. Repair any wires that are loose or frayed before you operate the engine. Clean all electrical connections and tighten all electrical connections.

Eliminate all wiring that is unattached or unnecessary. Do not use any wires or cables that are smaller than the recommended gauge. Do not bypass any fuses and/or circuit breakers.

Arcing or sparking could cause a fire. Secure connections, recommended wiring, and correctly maintained battery cables will help to prevent arcing or sparking.

Ensure that the engine is stopped. Inspect all lines and hoses for wear damage, leakage or for deterioration. Ensure that the hoses are correctly routed. The lines and hoses must have adequate support and secure clamps.

Safety Section  
Fire Prevention and Explosion Prevention

Oil filters and fuel filters must be installed correctly. The filter housings must be tightened to the correct torque. Refer to the Disassembly and Assembly manual for more information.



Illustration 21

g00704059

Use caution when you are refueling an engine. Do not smoke whilst you are refueling an engine. Do not refuel an engine near open flames or sparks. Always stop the engine before refueling.

Avoid static electricity risk when fueling. Ultra-low Sulfur Diesel fuel (ULSD fuel) poses a greater static ignition hazard than earlier diesel formulations with a higher sulfur content. Avoid death or serious injury from fire or explosion. Consult your fuel or fuel system supplier to ensure that the delivery system is in compliance with fueling standards for proper grounding and bonding practices.

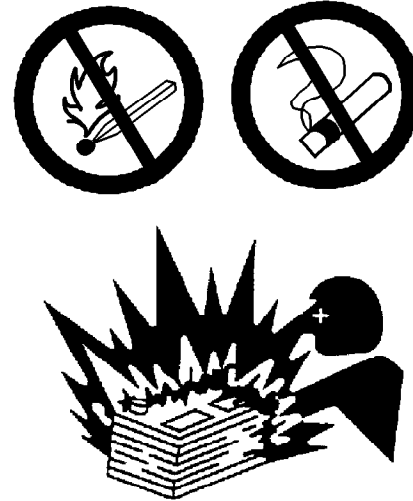

Illustration 22

g00704135

Gases from a battery can explode. Keep any open flames or sparks away from the top of a battery. Do not smoke in battery charging areas.

Never check the battery charge by placing a metal object across the terminal posts. Use a voltmeter or a hydrometer.

Incorrect jumper cable connections can cause an explosion that can result in injury. Refer to the Operation Section of this manual for specific instructions.

Do not charge a frozen battery. A frozen battery may cause an explosion.

The batteries must be kept clean. The covers (if equipped) must be kept on the cells. Use the recommended cables, connections, and battery box covers when the engine is operated.

## Fire Extinguisher

Make sure that a fire extinguisher is available. Be familiar with the operation of the fire extinguisher. Inspect the fire extinguisher and service the fire extinguisher regularly. Obey the recommendations on the instruction plate.

## Ether

Ether is flammable and poisonous.

Do not smoke whilst you are replacing an ether cylinder or whilst you are using an ether spray.

Do not store ether cylinders in living areas or in the engine compartment. Do not store ether cylinders in direct sunlight or in temperatures above 49° C (120° F). Keep ether cylinders away from open flames or sparks.

i05875651

## Lines, Tubes, and Hoses

Do not bend high-pressure lines. Do not strike high-pressure lines. Do not install any lines that are damaged.

Leaks can cause fires. Consult your Perkins distributor for replacement parts.

Replace the parts if any of the following conditions are present:

- End fittings are damaged or leaking.
- Outer coverings are chafed or cut.
- Wires are exposed.
- Outer coverings are ballooning.
- Flexible parts of the hoses are kinked.
- Outer covers have embedded armoring.
- End fittings are displaced.

Make sure that all clamps, guards, and heat shields are installed correctly. During engine operation, correct installation will help to prevent vibration, rubbing against other parts, and excessive heat.

i02143194

## Crushing Prevention and Cutting Prevention

Support the component correctly when work beneath the component is performed.

Unless other maintenance instructions are provided, never attempt adjustments while the engine is running.

Stay clear of all rotating parts and of all moving parts. Leave the guards in place until maintenance is performed. After the maintenance is performed, reinstall the guards.

Keep objects away from moving fan blades. The fan blades will throw objects or cut objects.

When objects are struck, wear protective glasses in order to avoid injury to the eyes.

Chips or other debris may fly off objects when objects are struck. Before objects are struck, ensure that no one will be injured by flying debris.

## Mounting and Dismounting

Do not climb on the engine. The engine has not been designed with mounting or dismounting locations.

Refer to the OEM for the location of foot and hand holds for your specific application.

i10005610

## Before Starting Engine

### NOTICE

For initial start-up of a new or rebuilt engine, and for start-up of an engine that has been serviced, make provision to shut the engine off should an overspeed occur. This may be accomplished by shutting off the air and/or fuel supply to the engine.

### WARNING

**Engine exhaust contains products of combustion which may be harmful to your health. Always start and operate the engine in a well ventilated area and, if in an enclosed area, vent the exhaust to the outside.**

Inspect the engine for potential hazards.

Do not start the engine or move any of the controls if there is a "DO NOT OPERATE" warning tag or similar warning tag attached to the start switch or to the controls.

Before starting the engine, ensure that no one is on, underneath, or close to the engine. Ensure that the area is free of personnel.

If equipped, ensure that the lighting system for the engine is suitable for the conditions. Ensure that all lights work properly, if equipped.

All protective guards and all protective covers must be installed if the engine must be started to perform service procedures. To help prevent an accident that is caused by parts in rotation, work around the parts carefully.

Do not bypass the automatic shutoff circuits. Do not disable the automatic shutoff circuits. The circuits are provided to help prevent personal injury. The circuits are also provided to help prevent engine damage.

i06545901

## Engine Starting

### WARNING

**Do not use aerosol types of starting aids such as ether. Such use could result in an explosion and personal injury.**

If a warning tag is attached to the engine start switch, or to the controls DO NOT start the engine or move the controls. Consult with the person that attached the warning tag before the engine is started.

All protective guards and all protective covers must be installed if the engine must be started to perform service procedures.

Start the engine from the operators compartment or from the engine start switch.

Always start the engine according to the procedure that is described in the Operation and Maintenance Manual, “Engine Starting” topic in the Operation Section. Knowing the correct procedure will help to prevent major damage to the engine components. Knowing the procedure will also help to prevent personal injury.

Ensure that the jacket water heater (if equipped) is working correctly, check the water temperature reading on the control panel of the original engine manufacture.

Engine exhaust contains products of combustion which can be harmful to your health. Always start the engine and operate the engine in a well ventilated area. If the engine is started in an enclosed area, vent the engine exhaust to the outside.

**Note:** The engine may be equipped with a device for cold starting. If the engine will be operated in cold conditions, then an extra cold starting aid may be required. Normally, the engine will be equipped with the correct type of starting aid for your region of operation.

i09160524

## Engine Stopping

- Remove the load in increments.
- Open the circuit breaker.
- Allow the engine to run for five minutes to cool.
- Stop the engine.

- Ensure 24V is supplied to the dosing cabinet for at least 120 seconds after engine shutdown (engines equipped with SCR systems only).

Use the Emergency Stop Button (if equipped) ONLY in an emergency situation. Do not use the Emergency Stop Button for normal engine stopping. After an emergency stop, DO NOT start the engine until the problem that caused the emergency stop has been corrected.

Stop the engine if an overspeed condition occurs during the initial start-up of a new engine or an engine that has been overhauled. This may be accomplished by shutting off the fuel supply to the engine and/or shutting off the air supply to the engine.

To stop an electronically controlled engine, cut the power to the engine.

i06088340

## Electrical System

Never disconnect any charging unit circuit or battery circuit cable from the battery when the charging unit is operating. A spark can cause the combustible gases that are produced by some batteries to ignite.

To help prevent sparks from igniting combustible gases that are produced by some batteries, the negative “-” jump-start cable should be connected last from the external power source to the negative “-” terminal of the starting motor. If the starting motor is not equipped with a negative “-” terminal, connect the jump-start cable to the engine block.

Check the electrical wires daily for wires that are loose or frayed. Tighten all loose electrical wires before the engine is started. Repair all frayed electrical wires before the engine is started. Refer to the “Engine Starting” section of this Operation and Maintenance Manual for specific starting instructions.

## Grounding Practices

Proper grounding for the engine electrical system is necessary for optimum engine performance and reliability. Improper grounding will result in uncontrolled electrical circuit paths and in unreliable electrical circuit paths.

Uncontrolled electrical circuit paths can result in damage to main bearings, to crankshaft bearing journal surfaces, and to aluminum components.

Engines that are installed without engine-to-frame ground straps can be damaged by electrical discharge.

To ensure that the engine and the engine electrical systems function properly, an engine-to-frame ground strap with a direct path to the battery must be used. This path may be provided by way of a starting motor ground, a starting motor ground to the frame, or a direct engine ground to the frame.

All grounds should be tight and free of corrosion. The engine alternator must be grounded to the negative “-” battery terminal with a wire that is adequate to handle the full charging current of the alternator.

i08227685

The Engine Monitoring package can vary for different engine models and different engine applications. However, the monitoring system and the engine monitoring control will be similar for all engines.

**Note:** Many of the engine control systems and display modules that are available for Perkins Engines will work in unison with the Engine Monitoring System. Together, the two controls will provide the engine monitoring function for the specific engine application. Refer to the Troubleshooting Manual for more information.

## Engine Electronics

### WARNING

**Tampering with the electronic system installation or the OEM wiring installation can be dangerous and could result in personal injury or death and/or engine damage.**

This engine has a comprehensive, programmable Engine Monitoring System. The Engine Control Module (ECM) will monitor the engine operating conditions. If any of the engine parameters extend outside an allowable range, the ECM will initiate an immediate action.

The following actions are available for engine monitoring control: WARNING, DERATE, and SHUTDOWN. These engine monitoring modes can limit engine speed and/or the engine power.

Many of the parameters that are monitored by the ECM can be programmed for the engine monitoring functions. The following parameters can be monitored as a part of the Engine Monitoring System:

- Coolant Level
- Coolant Temperature
- Fuel Pressures
- Fuel Temperature
- Intake Manifold Air Temperature
- Intake Manifold Air Pressure
- Air inlet temperature
- Atmospheric pressure
- Engine Oil Pressure
- Engine Speed
- Water In Fuel

# Product Information Section

## Model Views

i09766575

## Model View Illustrations

The following model views show typical features of the engine. Due to individual applications, your engine may appear different from the illustrations.

## Engine Views

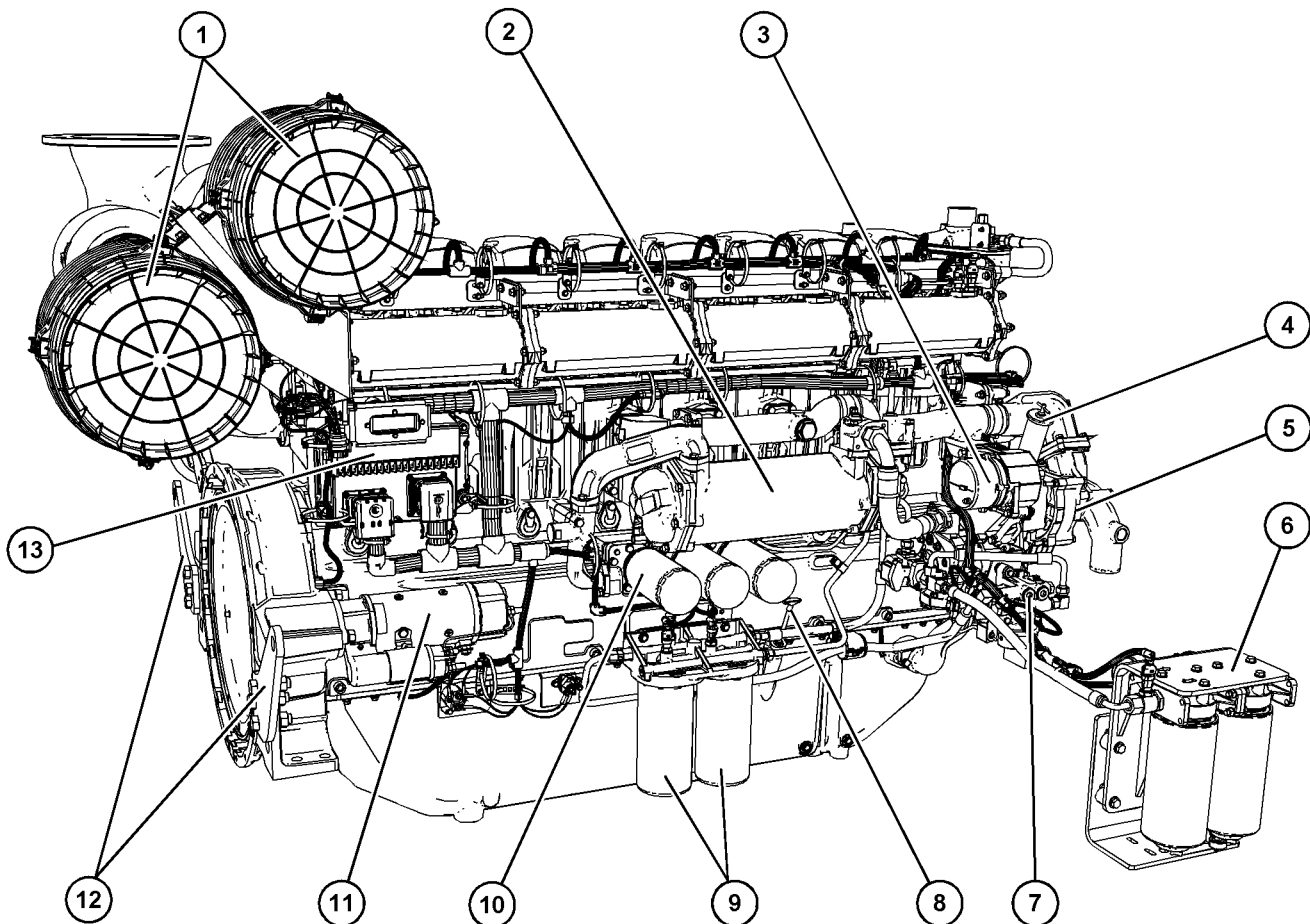

Illustration 23

g06617703

Typical example an earlier engine

- |                       |  |                                |
|-----------------------|--|--------------------------------|
| (1) Twin air cleaners | (6) Module for twin primary fuel filters | (11) Starting motor            |
| (2) Oil cooler        | (7) Electric priming pump                | (12) Rear lifting eyes         |
| (3) Alternator        | (8) Oil gauge (Dipstick)                 | (13) Electronic control module |
| (4) Oil filler        | (9) Twin secondary fuel filters          |                                |
| (5) Coolant pump      | (10) Oil filters                         |                                |

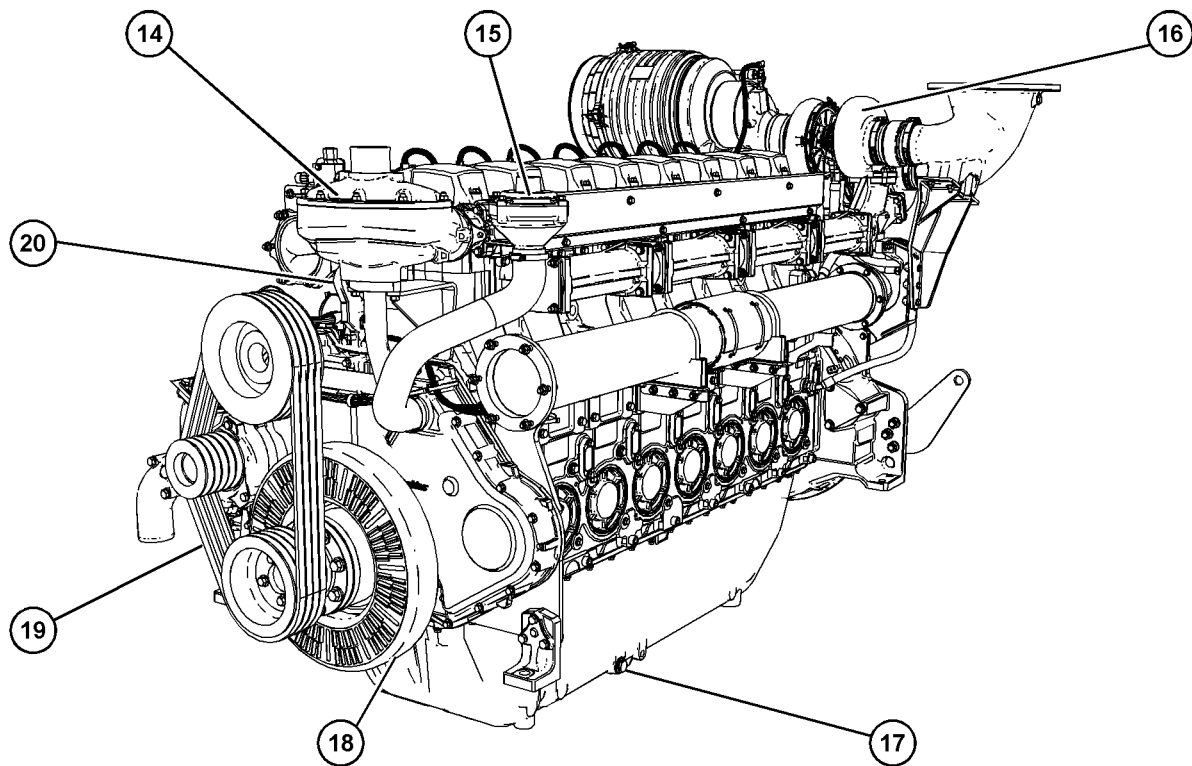

Illustration 24

g06643111

**Typical example an earlier engine**

(14) Thermostat housing  
(15) Breather  
(16) Turbochargers

(17) Oil drain plug  
(18) Crankshaft damper  
(19) Fan belts

(20) Front lifting eye

## Radiator View

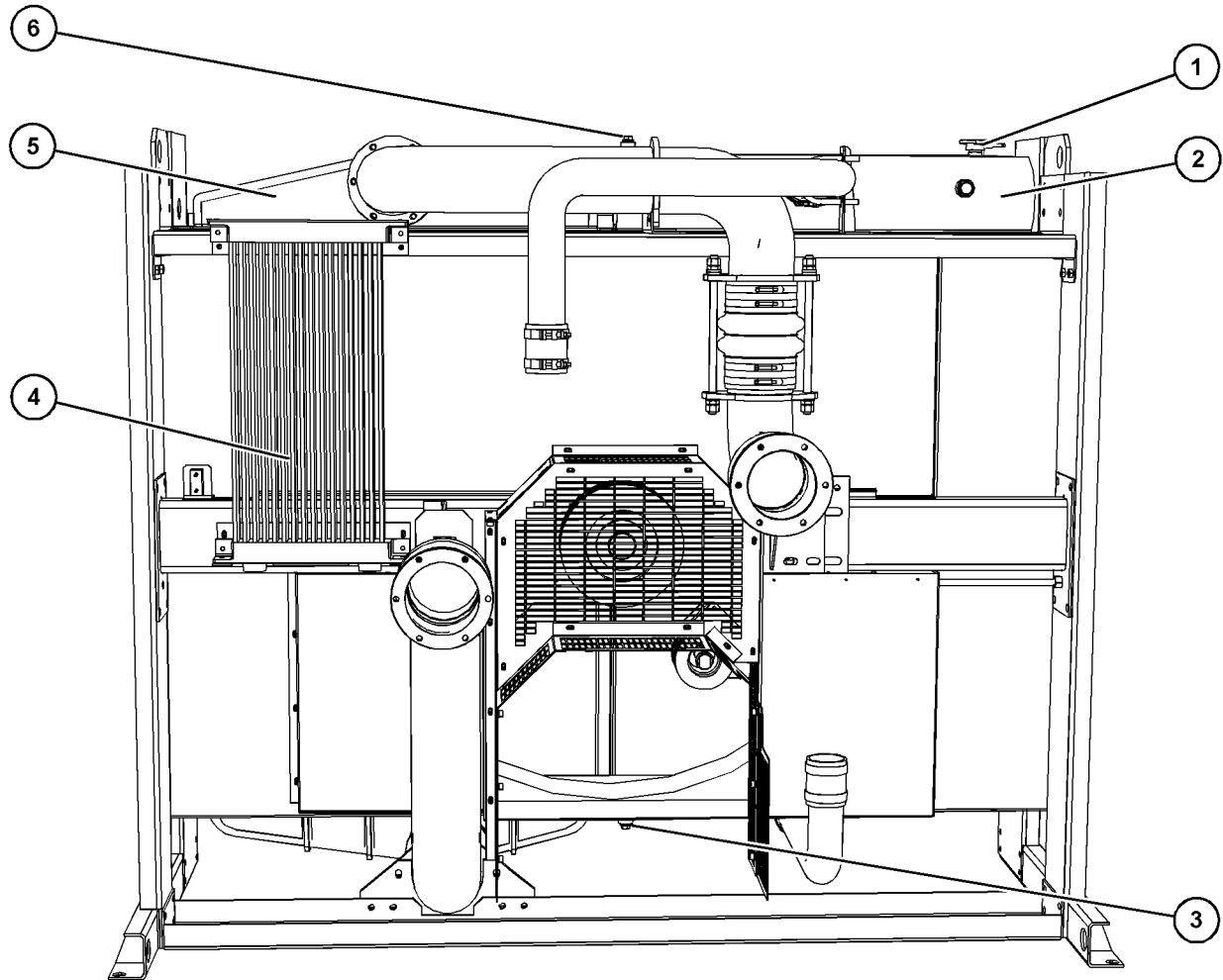

Illustration 25

g06618854

Typical example of an earlier Radiator

(1) Radiator cap  
(2) Radiator

(3) Coolant drain  
(4) Fuel cooler

(5) Air to air charge cooler  
(6) Coolant vent



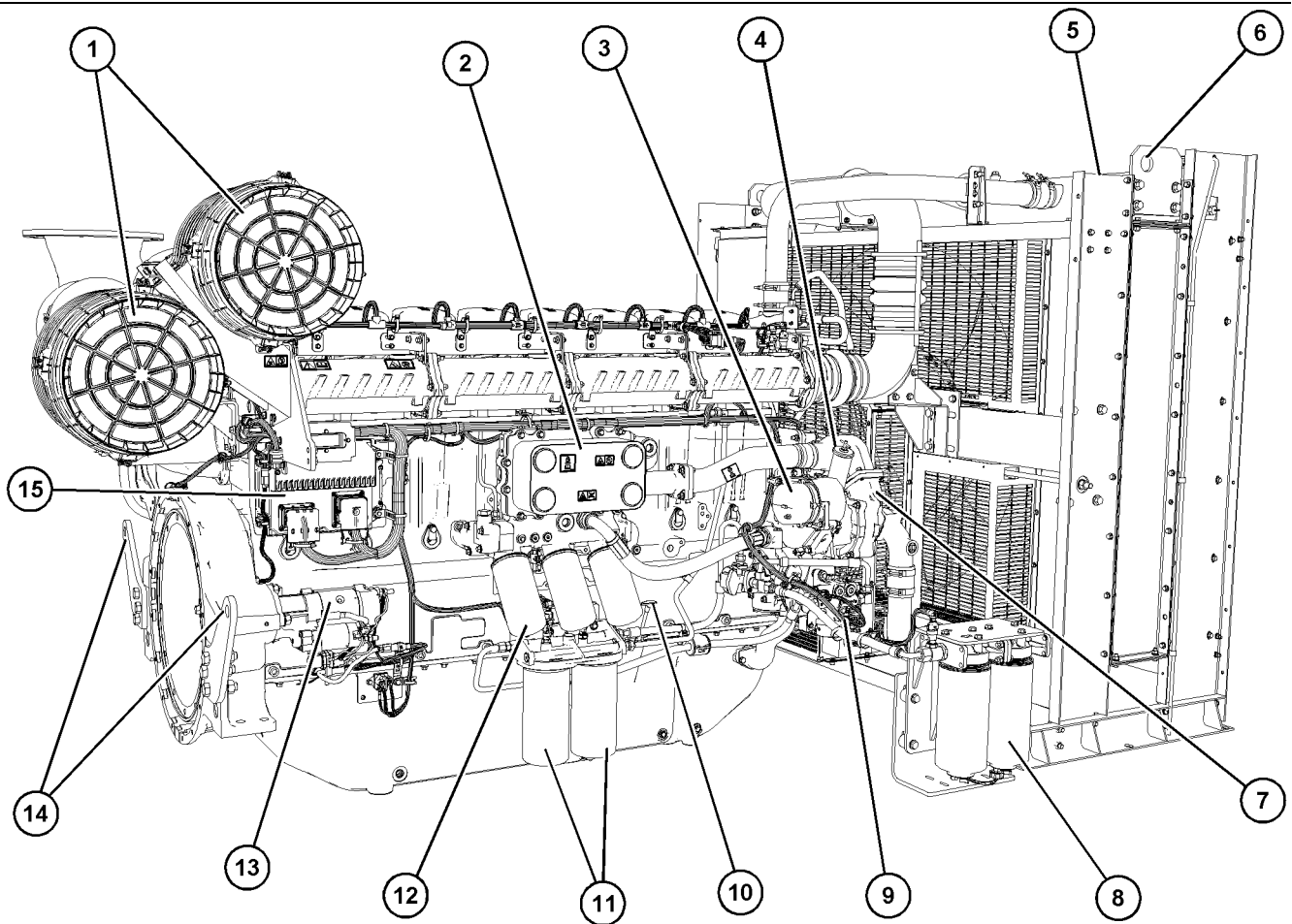

Illustration 26

g07584153

### Typical example a later engine

- |                       |  |                                  |
|-----------------------|--|----------------------------------|
| (1) Twin air cleaners | (6) Radiator lifting eye (1 of 2)        | (11) Twin secondary fuel filters |
| (2) Oil cooler        | (7) Coolant pump                         | (12) Oil filters                 |
| (3) Alternator        | (8) Module for twin primary fuel filters | (13) Starting motor              |
| (4) Oil filler        | (9) Electric priming pump                | (14) Rear lifting eyes           |
| (5) Radiator          | (10) Oil gauge (Dipstick)                | (15) Electronic control module   |

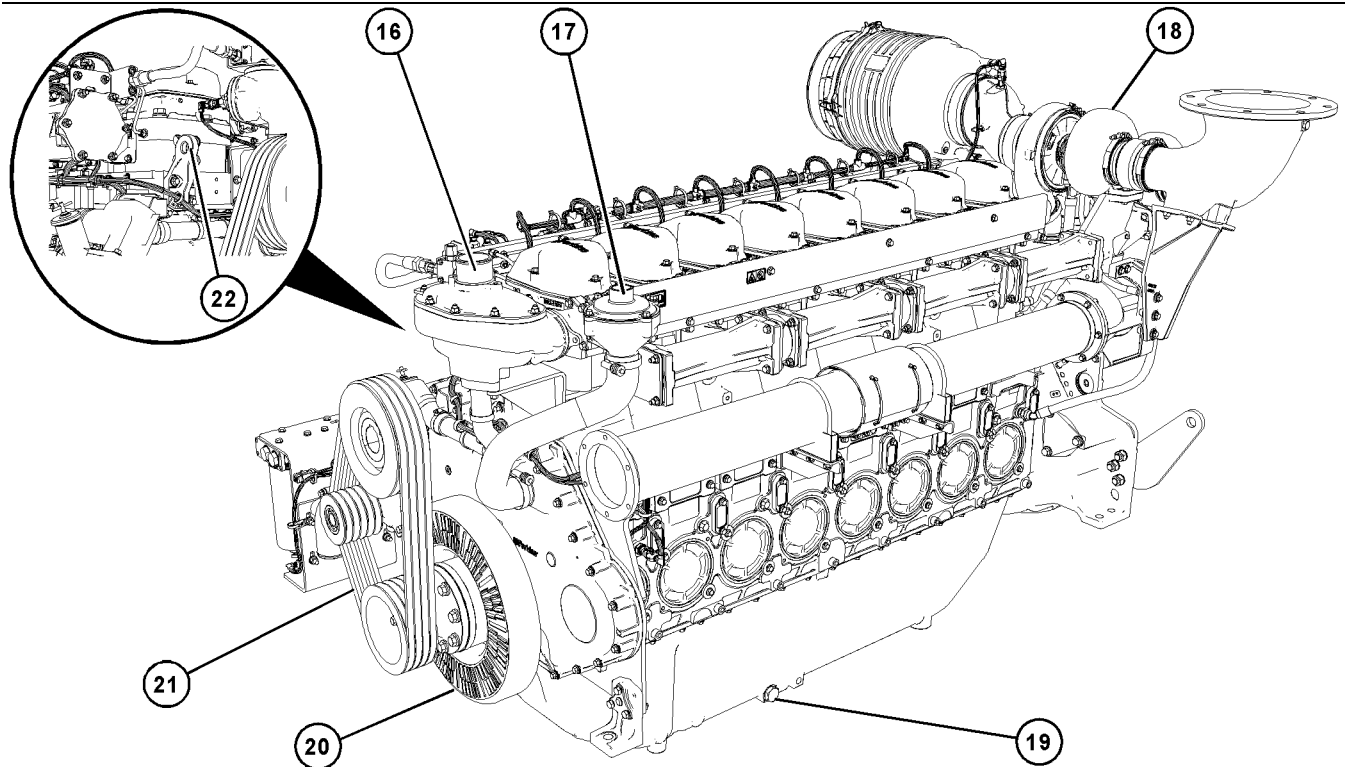

Illustration 27

g07584823

Typical example a later engine with radiator removed

(16) Thermostat housing  
(17) Breather  
(18) Turbochargers

(19) Oil drain plug  
(20) Crankshaft damper  
(21) Fan belts

(22) Front lifting eye

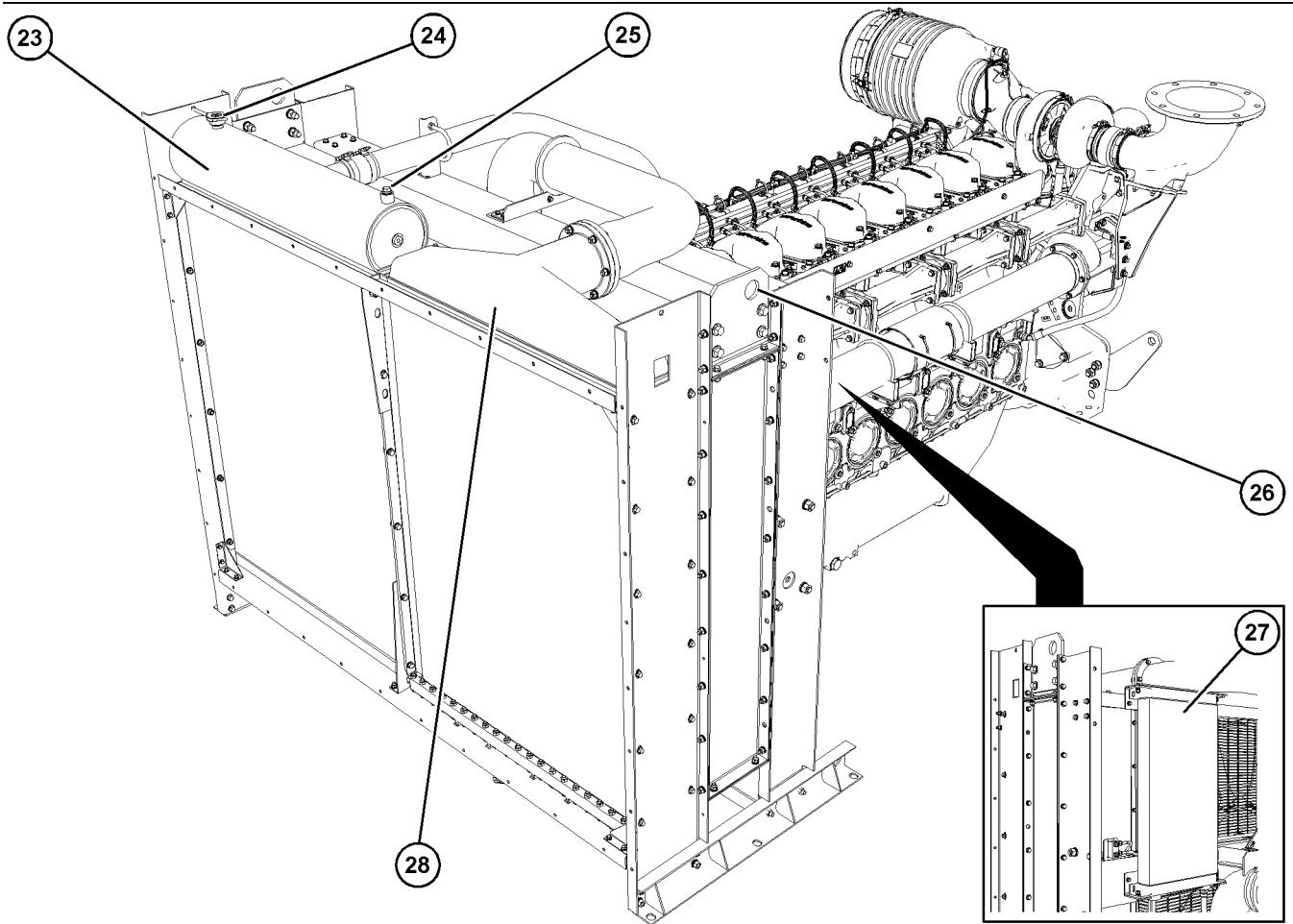

Illustration 28

g07585157

Typical example of a later engine

(23) Radiator  
(24) Radiator cap

(25) Coolant vent  
(26) Radiator lifting eye (2 of 2)

(27) Fuel cooler  
(28) Air to air charge cooler

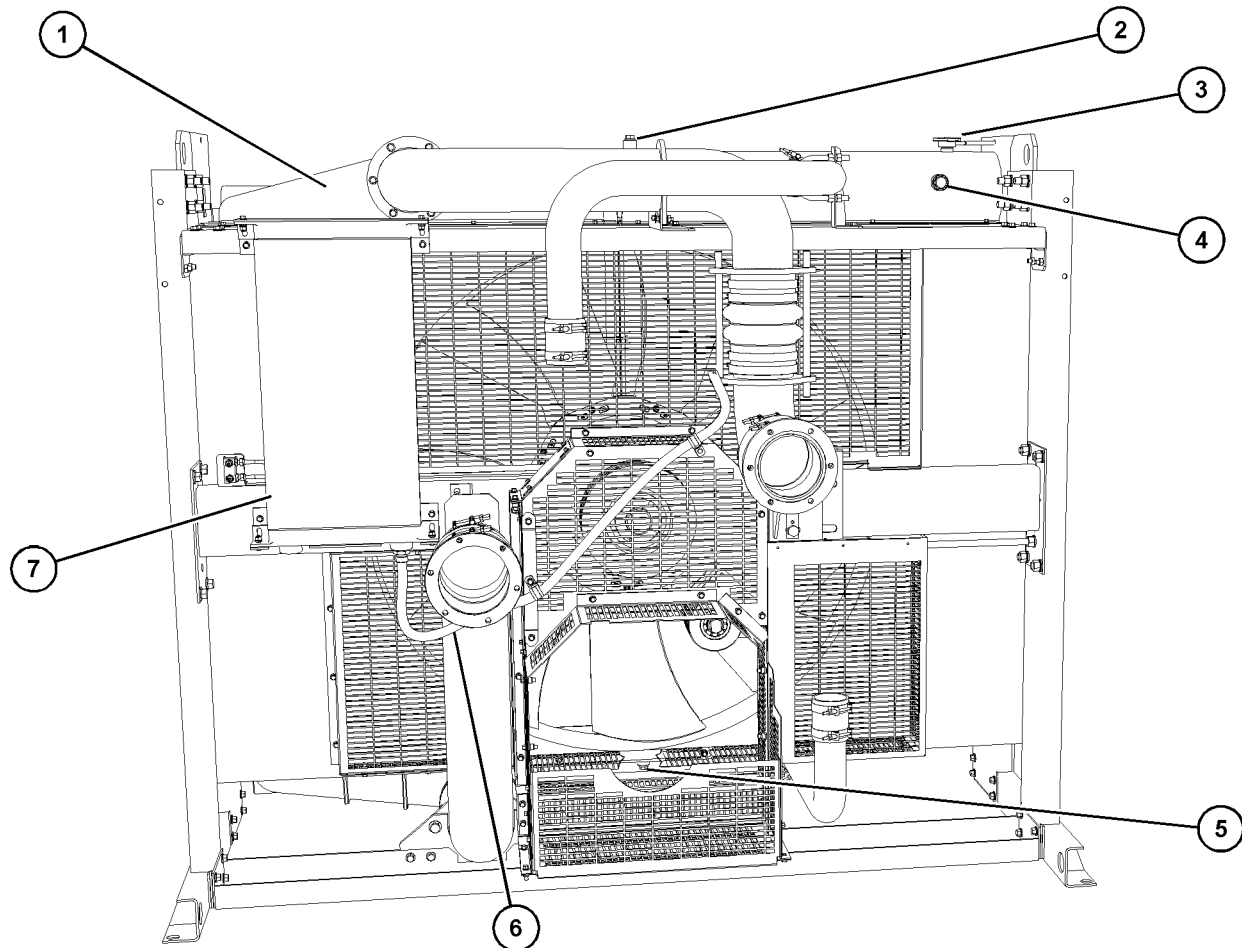

Illustration 29

g07602920

### Typical example of a later Radiator

- |                              |                         |                 |
|------------------------------|-------------------------|-----------------|
| (1) Air to air charge cooler | (4) Radiator            | (7) Fuel cooler |
| (2) Coolant vent             | (5) Coolant drain       |                 |
| (3) Radiator cap             | (6) Fuel pipe (partial) |                 |

Fan guards have been partially removed for clarity.

i10199205

## Engine Description

The Perkins 5006A-E23TA, 5008A-E30TA, 5008C-E30TA, and 5008AC-E30TA Industrial Engines have the following characteristics:

- Four stroke cycle
- Mechanically actuated, electronically controlled fuel injection system
- Turbocharged
- Air to air charged cooled

## Engine Specifications

**Note:** The front end of the engine is opposite the flywheel end of the engine. The left and the right sides of the engine are determined from the flywheel end. The number 1 cylinder is the front cylinder.

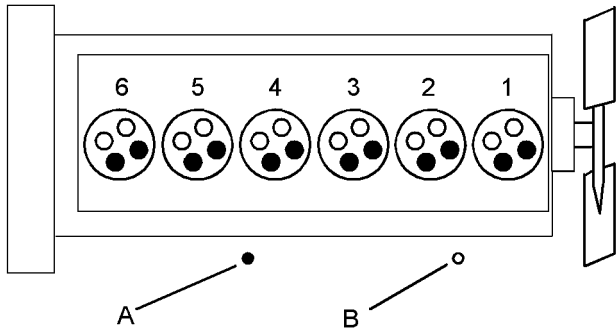

Illustration 30 g06253267

Typical example of a 6 cylinder engine

- (A) Inlet valves
- (B) Exhaust valves

Table 1

Engine Specifications	
Engine	5006A-E23TA
Arrangement and Cylinders	In-Line 6 cylinder
Bore	160 mm (6.30 inch)
Stroke	190 mm (7.48 inch)
Displacement	22.921 L (1398.73 cubic inch)
Compression Ratio	14:1
Firing Order	1-5-3-6-2-4
Aspiration	ATAAC <sup>(1)</sup>
Valve seat angle	20°
Valve lash	0.4 mm (0.01575 inch) Cold
Rotation (flywheel end)	Counterclockwise

<sup>(1)</sup> Air-to-air aftercooled

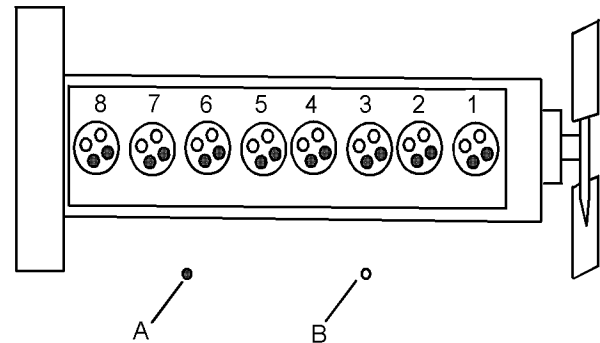

Illustration 31 g01207434

Typical example of an 8 cylinder engine

- (A) Inlet valves
- (B) Exhaust valves

Table 2

Engine Specifications	
Engine	5008A-E30TA, 5008C-E30TA, and 5008AC-E30TA
Arrangement and cylinders	In-line 8 cylinder
Bore	160 mm (6.30 inch)
Stroke	190 mm (7.48 inch)
Displacement	30.56 L (1864.89 cubic inch)
Compression Ratio	14:1
Firing order	1-4-7-6-8-5-2-3
Aspiration	ATAAC <sup>(1)</sup>
Valve seat angle	20°
Valve lash	0.4 mm (0.01575 inch) Cold
Rotation (flywheel end)	Counterclockwise

<sup>(1)</sup> Air-to-air aftercooled

## Electronic Engine Features

The engine is designed for electronic controls. The integral on board computer controls the operation of the engine. Current operating conditions are monitored. The Electronic Control Module (ECM) controls the response of the engine to these conditions and to the demands of the operator. These conditions and operator demands determine the precise control of fuel injection by the ECM. The electronic engine control system provides the following features:

- Engine speed governor
- Automatic air/fuel ratio control
- Torque rise shaping

- Injection timing control
- System diagnostics

### Extra Features

The following extra features provide increased engine fuel economy and serviceability:

- Cold starting capability
- Tampering detection
- Diagnostics

### Engine Service Life

Engine efficiency and maximum utilization of engine performance depend on the adherence to proper operation and maintenance recommendations. In addition, use recommended fuels, coolants, and lubricants. Use the Operation and Maintenance Manual as a guide for required engine maintenance.

Expected engine life is predicted by the average power that is demanded. The average power that is demanded is based on fuel consumption of the engine over a time. Reduced hours of operation at full throttle and/or operating at reduced throttle settings result in a lower average power demand. Reduced hours of operation will increase the length of operating time before an engine overhaul is required. For more information, refer to the Operation and Maintenance Manual, "Overhaul Considerations" topic.

**Operation of emergency engines is limited to emergency operations and required maintenance and testing.**

### Aftermarket Products and Perkins Engines

Perkins does not warrant the quality or performance of non-Perkins fluids and filters.

When auxiliary devices, accessories, or consumables (filters, additives, catalysts) which are made by other manufacturers are used on Perkins products, the Perkins warranty is not affected simply because of such use.

**However, failures that result from the installation or use of other manufacturers devices, accessories, or consumables are NOT Perkins defects. Therefore, the defects are NOT covered under the Perkins warranty.**

# Product Identification Information

i10195756

## Plate Locations and Film Locations

The engine serial number plate is on the right side rear of the engine. The serial number with ratings information label will be in the same location on some engines.

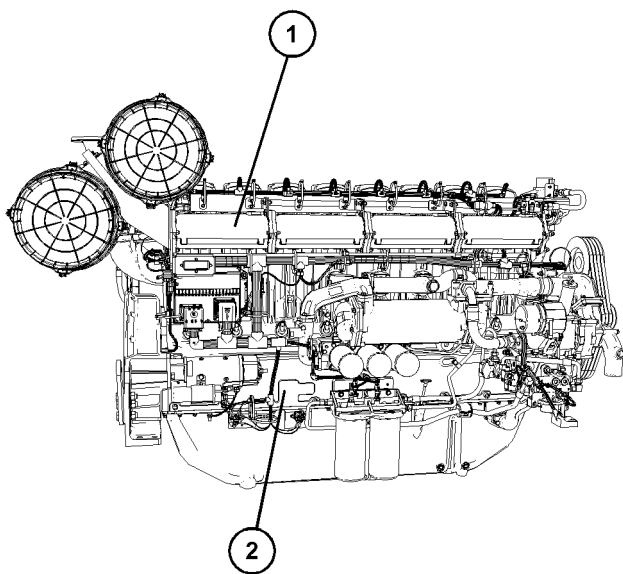

Illustration 32 g06649081

Typical example of an earlier engine

- (1) Emission label location
- (2) Engine serial number plate and engine ratings labels location

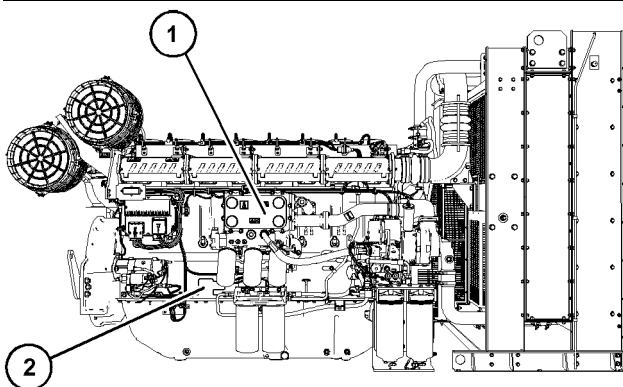

Illustration 33 g07789122

Typical example of a later engine

- (1) Emission label location
- (2) Engine serial number plate and engine ratings labels location

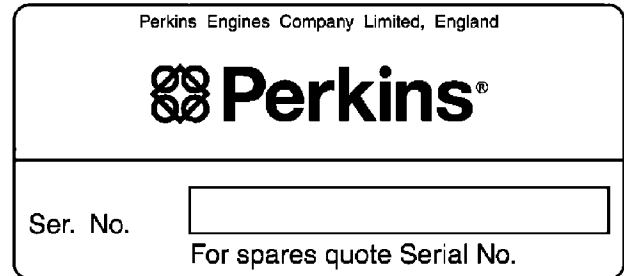

Illustration 34 g06649090

Typical example of engine serial number plate

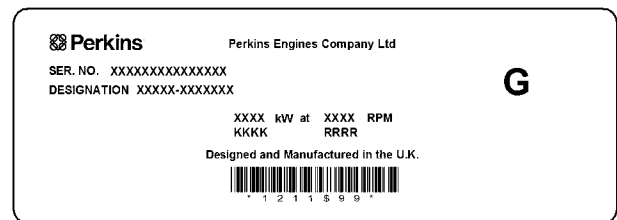

Illustration 35 g07789137

Typical example of a type 1 serial number with ratings information label

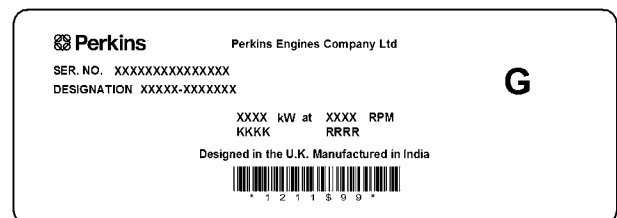

Illustration 36 g07789135

Typical example of a type 2 serial number with ratings information label

Your Perkins distributor needs all the number from these labels when service information is required.

## Emission Label

The emission label (1) is installed on the inlet manifold on earlier engines and on the oil cooler on later engines.

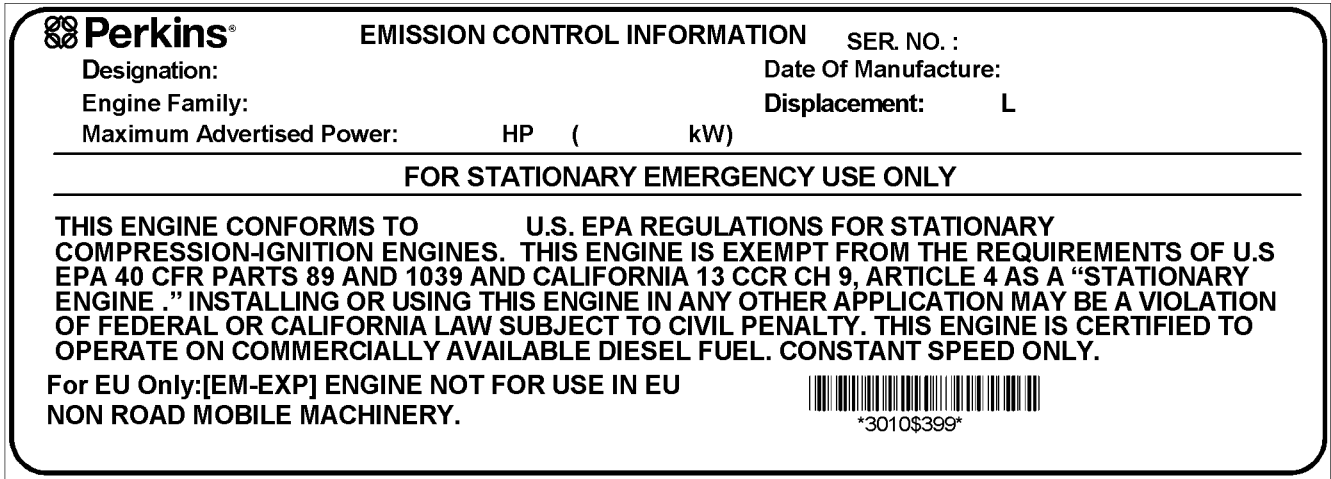

Illustration 37

g06646849

Typical example of type 1 Emissions label



Illustration 38

g07789140

Typical example of type 2 Emissions label



# Operation Section

## Lifting and Storage

i09768521

### Product Lifting

#### Engine Only - Earlier Engines

**NOTICE**

Always inspect lifting eyebolts and all other lifting equipment for damage before performing any lifting. Never bend the eyebolts and the brackets. Never perform product lifting if components are damaged.

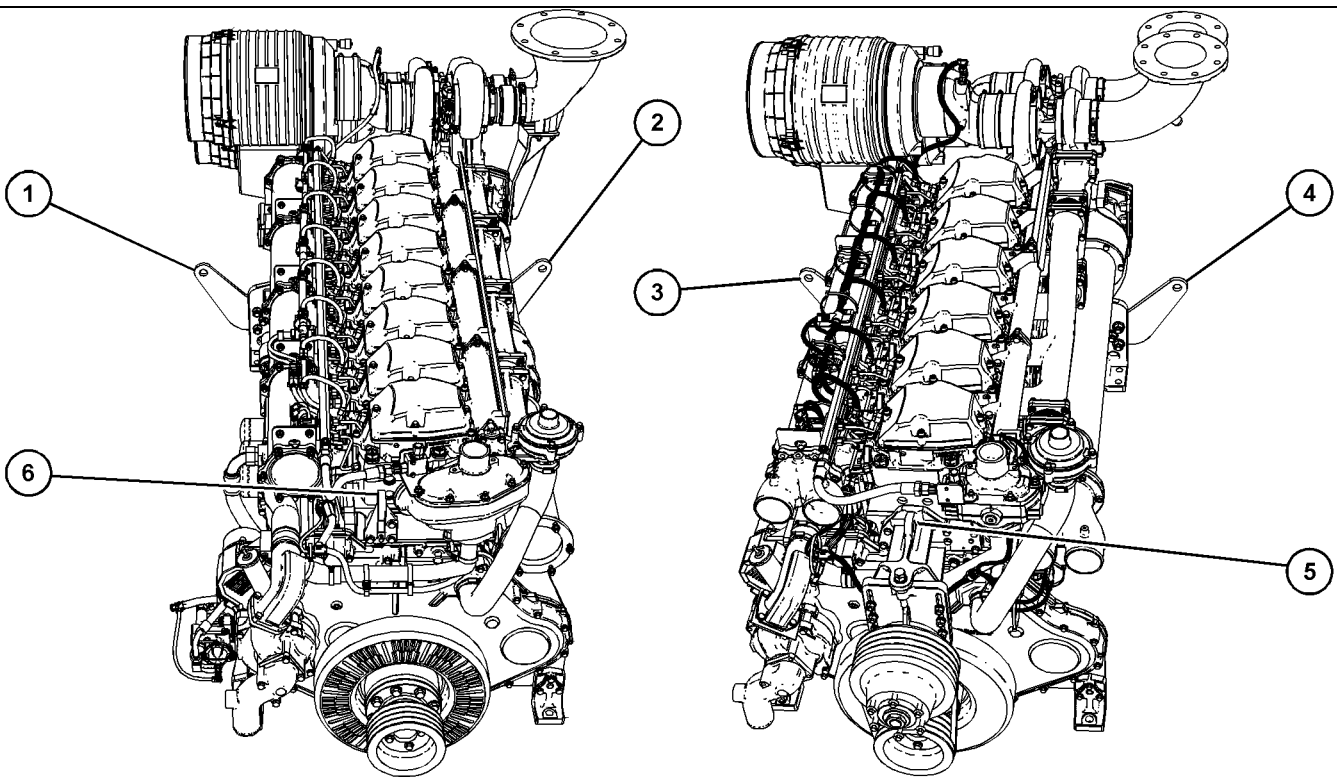

Illustration 39

g06649619

#### Typical example of earlier engines

- (1) 5008 engine Rear lifting eye
- (2) 5008 engine Rear lifting eye

- (3) 5006 engine Rear lifting eye
- (4) 5006 engine Rear lifting eye

- (5) 5006 engine Front lifting eye
- (6) 5008 engine Front lifting eye

## Radiator Only

---

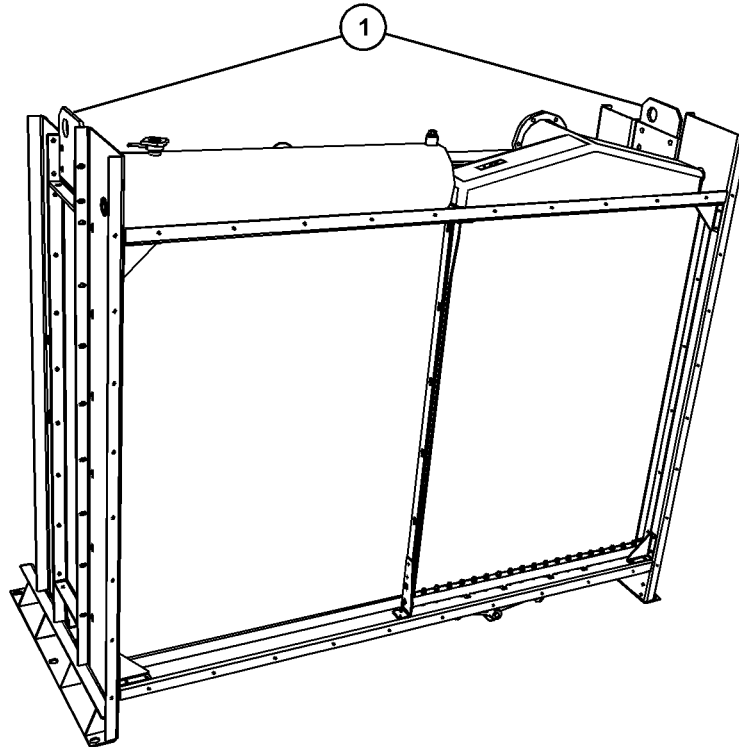

---

Illustration 40

Typical example of a 5008 radiator

g06649667

(1) Radiator lifting eyes

### Later engines

On later engines, the radiator and the engine are to be disassembled before lifting and to be lifted separately.

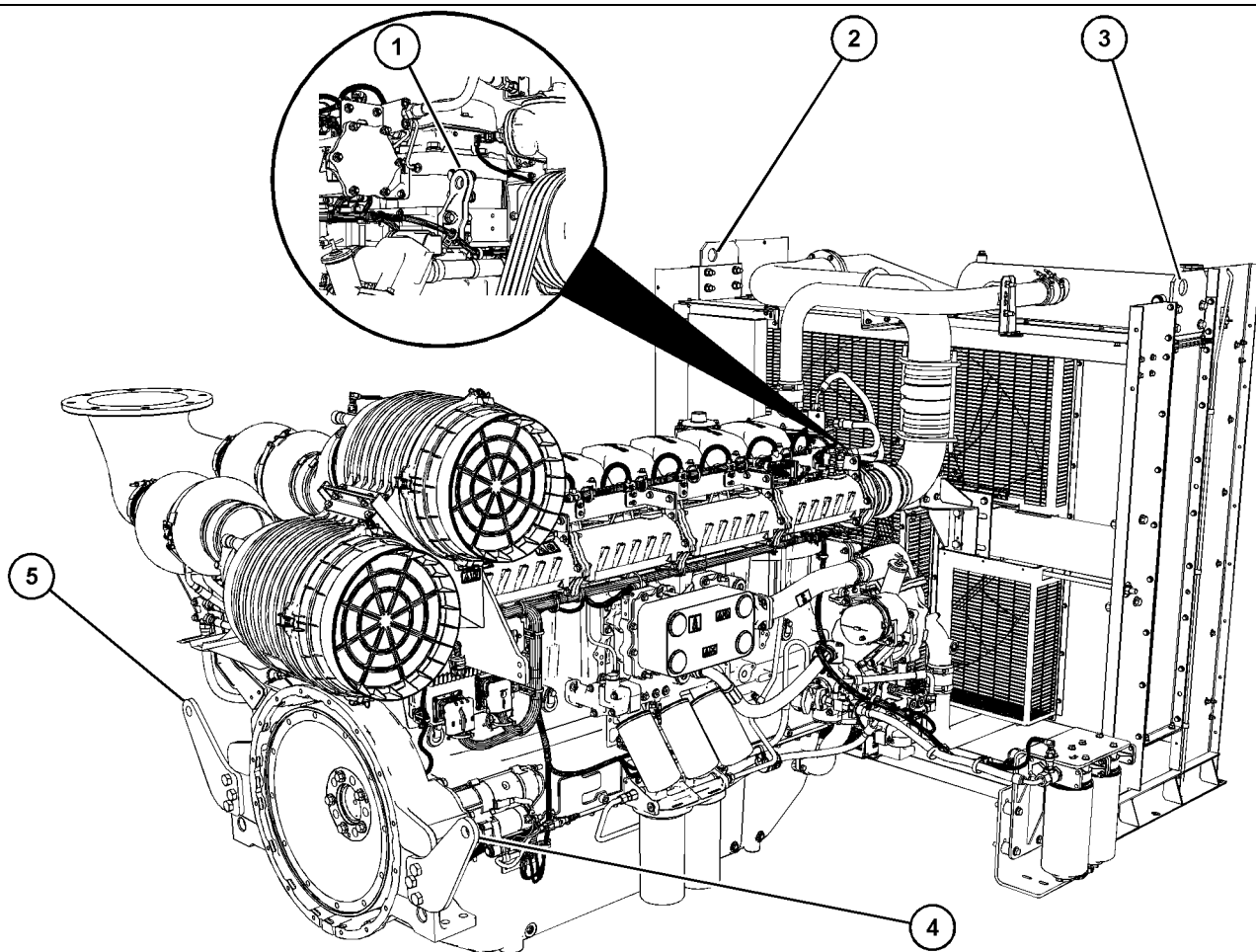

Illustration 41

g07585967

Typical example of a later engine  
Some parts are removed for clarity

(1) Engine Front lifting eye  
(2) Radiator lifting eye (1 of 2)

(3) Radiator lifting eye (2 of 2)  
(4) Engine Rear lifting eye (1 of 2)

(5) Engine Rear lifting eye (2 of 2)

i09811347

## Condition for Storage

## Product Storage

Perkins are not responsible for damage which may occur when an engine is in storage after a period in service.

Your Perkins distributor can help with preparing the engine for extended storage periods.

The engine must be stored in a water proof building. The building must be kept at a constant temperature. Engines that are filled with Perkins ELC will have coolant protection to an ambient temperature of  $-36^{\circ}\text{C}$  ( $-32.8^{\circ}\text{F}$ ). The engine must not be subjected to extreme variations in temperature and humidity.

The engine has to be prepared in the following order:

- Air
- Coolant
- Lubricant

Engines must be kept in Vapor Corrosion Inhibitor (VCI) bags during storage. Periodically check the bag for damage. If bag is damaged, install a new bag or new bags.

## Engine

1. Clean the engine of any dirt, rust, grease, and oil. Inspect the exterior. Paint areas that contain paint damage with a good quality paint.
2. Remove dirt from the air cleaners. Check all seals, gaskets, and the filter element for damage.
3. Apply lubricant to all points in this Operation and Maintenance Manual, "Maintenance Interval Schedule".
4. Drain the crankcase oil. Replace the oil filters and crankcase oil. For the correct procedure, refer to this Operation and Maintenance Manual.
5. Add a mixture of 50 % Vapor Corrosion Inhibitor (VCI) oil and 50% engine oil to the engine.

**Note:** If the engine crankcase is full, drain enough engine oil so the mixture can be added.

6. Remove the air filter elements. Turn the engine at cranking speed. Use a sprayer to add a mixture of 50 percent VCI oil and 50 percent engine oil into the air inlet or turbocharger inlet.

**Note:** The mixture can be added to the inlet by removing the plug on the air inlet elbow on the left side of the engine. The minimum application rate for the VCI oil mixture is 5.5 mL per L (3 oz per 1000 cu in) of engine displacement.

7. Use a sprayer to apply a mixture of 50 percent VCI oil and 50 percent crankcase oil into the exhaust openings. The minimum application rate for the oil mixture is 5.5 mL per L (3 oz per 1000 cu in) of engine displacement. Seal the exhaust pipe and seal any drain holes in the muffler.

8. Remove, empty, and reinstall the spin-on fuel filter element to remove any dirt and water.

Remove, empty, and clean the primary fuel filter. Fill with calibration fluid or kerosene. Install the primary fuel filter and operate the priming pump. This procedure will send the fluid to the secondary filter and the engine.

Open the fuel tank drain valve to drain any water and dirt from the fuel tank. Apply a spray of calibration fluid or kerosene at the rate of 30 mL per 30 L (1 oz per 7.50 gal US) of fuel tank capacity to prevent rust in the fuel tank. Add 0.15 mL per L (.02 oz per 1 gal US) of commercial biocide such as Biobor JF to the fuel. Refer to "Perkins Diesel Engines Fluids Recommendations" M0113102 for more information.

Apply a small amount of oil to the threads on the fuel tank filler neck and install the cap. Seal all openings to the tank to prevent evaporation of the fuel and as a preservative.

9. Remove the fuel injectors. Apply 30 mL (1 oz) of the mixture of oils (50 percent VCI oil and 50 percent engine oil) into each cylinder.

Use a bar or a turning tool to turn over the engine slowly. This procedure puts the oil on the cylinder walls. Install all fuel injectors and tighten to the correct torque. Refer to Disassembly and Assembly Manual for more information.

10. Spray a thin amount of a mixture of 50 percent VCI oil and 50 percent engine oil onto the following components: flywheel, ring gear teeth, and starter pinion. Install the covers to prevent evaporation of the vapors from the VCI oil.

11. Apply a heavy amount of Multipurpose Grease to all outside parts that move, such as rod threads, ball joints, linkage.

**Note:** Install all covers. Ensure that tape has been installed over all openings, air inlets, exhaust openings, the flywheel housing, the crankcase breathers, the dipstick tubes.

Ensure that all covers are airtight and weatherproof. Use a waterproof weather resistant tape such as Kendall No. 231 or an equivalent. Do not use duct tape. Duct tape will only seal for a short time.

12. Under most conditions, removing the batteries is the best procedure. Place the batteries in storage. As needed, periodically charge the batteries while the batteries are in storage.

If the batteries are not removed, wash the tops of the batteries until the tops are clean. Apply an electrical charge to the batteries to obtain a specific gravity of 1.225.

Disconnect the battery terminals. Place a plastic cover over the batteries.

13. Remove the drive belts from the engine

14. Place a waterproof cover over the engine. Ensure that the engine cover is secure. The cover should be loose enough to allow air to circulate around the engine to prevent damage from condensation.
15. Attach a tag with the storage date to the engine.
16. Remove the waterproof cover at 2 month or 3 month intervals to check the engine for corrosion. If the engine has signs of corrosion, repeat the protection procedure.

## Coolant System

Completely fill the cooling system before storage.

Refer to “Perkins Diesel Engines Fluids Recommendations”M0113102 for more information about coolants.

## Remove Engine from Storage

1. Remove all outside protective covers.
2. Change the oil and filters.
3. Check the condition of the fan and alternator belts. Replace the belts, if necessary. Refer to this Operation and Maintenance Manual, “Belts - Inspect/Adjust/Replace” for the correct procedure.
4. Replace the fuel filter elements.
5. Remove the plastic covers from the air cleaner elements.
6. Use a bar or a turning tool to turn the engine in the normal direction of rotation. The procedure ensures that no hydraulic locks or resistance exist.
7. Before starting the engine, remove the valve cover or covers. Put a large amount of engine oil on the camshaft, cam followers, and valve mechanism to prevent damage to the mechanism.
8. If an engine is stored for more than 1 year, Perkins recommends prelubrication of the engine to avoid dry starting. Use a suitable pump to put engine oil into the engine oil system.

The pump will need to create a minimum pressure within the engine of 0.25 bar (3.6 psi). This pressure is needed for 15 seconds to lubricate the internal surfaces.

Ensure that the correct oil specification is used, refer to “Perkins Diesel Engines Fluids Recommendations”M0113102 for more information. Perkins recommends that the procedure must be performed in a minimum ambient temperature of 10° C (50° F).

9. Check the condition of all rubber hoses. Replace any worn hoses. Replace any damaged hoses.
10. Before start-up, ensure that coolant meets the requirements detailed in “Perkins Diesel Engines Fluids Recommendations”M0113102.

If the engine and cooling system is in storage for longer than 2 years, Perkins recommends re-flushing the cooling system with RPAM 700 AF at a 20 percent concentration to provide additional protection.

RPAM 700 AF is available through the following address: ChemtoolEnquiriesUK@Lubrizol.com.

**Note:** RPAM 700 AF can be shipped worldwide from the U.K. There are also distributors in Asia .

11. Ensure that the cooling system is clean. Ensure that the system is full. Ensure that the system has the correct amount of supplemental cooling system additive.
12. Prime the engine with clean diesel fuel before starting.
13. On the first day of operation, check the entire engine several times for leaks and correct operation.

# Features and Controls

i08227688

## Monitoring System

The monitoring system is designed to alert the operator to an immediate problem.

The engine has protection in two stages:

- Warning
- Shutdown

The engine protection may be overridden by the critical condition mode.

The Electronic Control Module (ECM) monitors the following parameters:

- Coolant Level
- Coolant Temperature
- Engine Speed
- Engine Oil Pressure
- Fuel Temperature
- Fuel Pressure
- Intake Manifold Air Temperature
- Water In Fuel (WIF)
- Air Inlet Temperature
- Inlet Manifold Pressure
- Atmospheric pressure

If the parameters exceed a trip point for a period that is longer than the delay period, the ECM logs an event code. The indicator switches to the ON position.

The following parameters are monitored for event codes:

- Coolant Level
- Coolant Temperature
- Engine Speed
- Engine Oil Pressure
- Fuel Temperature
- Fuel Pressure
- Intake Manifold Air Temperature

- Water In Fuel (WIF)

The temperature protection is disabled for a period when the engine is cranking to compensate for heat soak solutions.

The ECM has dedicated alarm outputs for each of the three stages of protection. There are also dedicated alarm outputs for oil pressure, coolant temperature, and overspeed events which are energized at any stage of protection.

## Warning Alarm

The Warning alarm informs the user that the engine is approaching a critical condition.

If the engine is in the Warning condition, then the event will be logged in the memory of the ECM. An event code will be transmitted over the Perkins Data link and the hard wired Warning output will be energized. If the engine is in the Warning condition, the event code and output will remain while the condition exists. The electronic service tool is used to remove the event code from the memory of the ECM. The trip point for the Warning alarm will be set to a factory default in production. The electronic service tool may be used to alter the trip point for a Warning within predefined limits.

## Shutdown

If the engine reaches the Shutdown condition, one of the following events has occurred: low lubricating oil pressure, low coolant level, high coolant temperature, Clean Fuel Module (CFM) filter restriction, or overspeed. The event will be logged in the memory of the ECM. The engine will be shut down. An event code will be transmitted over the Perkins Data link and the hard wired Shutdown output will be energized. The Shutdown condition will latch until the ECM is reset. The event code for the shutdown cannot be cleared from the memory of the ECM without using a factory password.

## Critical Protection Override

If the engine is in an application that is critical for safety, the protection system can be overridden to ensure the continuation of the power supply during engine fault conditions.

Critical Protection Override will be set by a switch input from the OEM. For example, switch to ground to disable a critical override. Critical Protection Override input can be enabled in the electronic service tool by use of a factory password.

When the Critical Protection Override feature is active, the ECM will continue to run the engine in all shutdown conditions except for overspeed shutdown. If the shutdown is overridden, an event code is generated. The ECM will log the event code. The ECM will energize the following: Warning, Shutdown, Oil Pressure, Coolant Temperature, and Overspeed outputs as normal. The warranty of the engine will be invalidated if the engine is operated in the following conditions: active event code and Critical Protection Override mode.

## Standard Warning Outputs

The ECM provides individual outputs to drive warning lamps or relays to indicate each of the following fault conditions:

- Diagnostic Fault and Warning
- Oil Pressure
- Coolant Temperature
- Overspeed
- Shutdown

If the ECM detects a warning for the coolant temperature, the output on the coolant temperature will be energized and the warning output will be energized. If the ECM detects a warning for low oil pressure, the output on the oil pressure will be energized and the warning output will be energized.

If the engine shuts down on low oil pressure the output on the low oil pressure will be energized and the output on the shutdown will be energized. If the engine shuts down on coolant temperature, or the engine shuts down on overspeed the dedicated output and the shutdown output will be energized.

## Shutdown Reset

The cause of an engine shutdown must be investigated. Corrective action must be taken before the system is reset to operate the engine.

After an engine shutdown, operate the reset input of the ECM or power down the controller.

Powering down the electronic control module can be achieved by the operation of the keyswitch into sleep mode. The electronic control module can be powered down by isolating the power supply to the electronic control module.

**Note:** The ECM cannot be reset by using the Reset input until the engine has stopped.

## Diagnostic

If there is a fault with an engine protection sensor on the engine, the engine activates a diagnostic code. The engine communicates the diagnostic code to the operator via the Diagnostic output. The diagnostic code provides an indication to the operator of a fault with the engine protection system. Running of the engine for a prolonged period in this condition may result in engine failure. The output is generally used to drive lamps or relays.

The following sensors are monitored to determine if the sensors are out of the normal range, an open circuit, or a short circuit:

- Air Inlet Temperature
- Barometric Pressure
- Lubricating Oil Pressure
- Inlet Manifold Pressure
- Inlet Manifold Temperature
- Fuel Temperature
- Fuel Pressures (Pre-primary filter if Clean Fuel Module (CFM) is installed, Post-Primary, Pre-Secondary, and Post-Secondary)
- Coolant Temperature
- Engine Speed
- Desired Speed Input

i09769765

## Sensors and Electrical Components (Sensors Only)

The illustrations within the following sections are typical location of the sensors or electrical components for an industrial engine. Specific engines may appear different due to differences in applications. Some items have been removed from engine for clarity.

## Earlier Engine Sensor Views

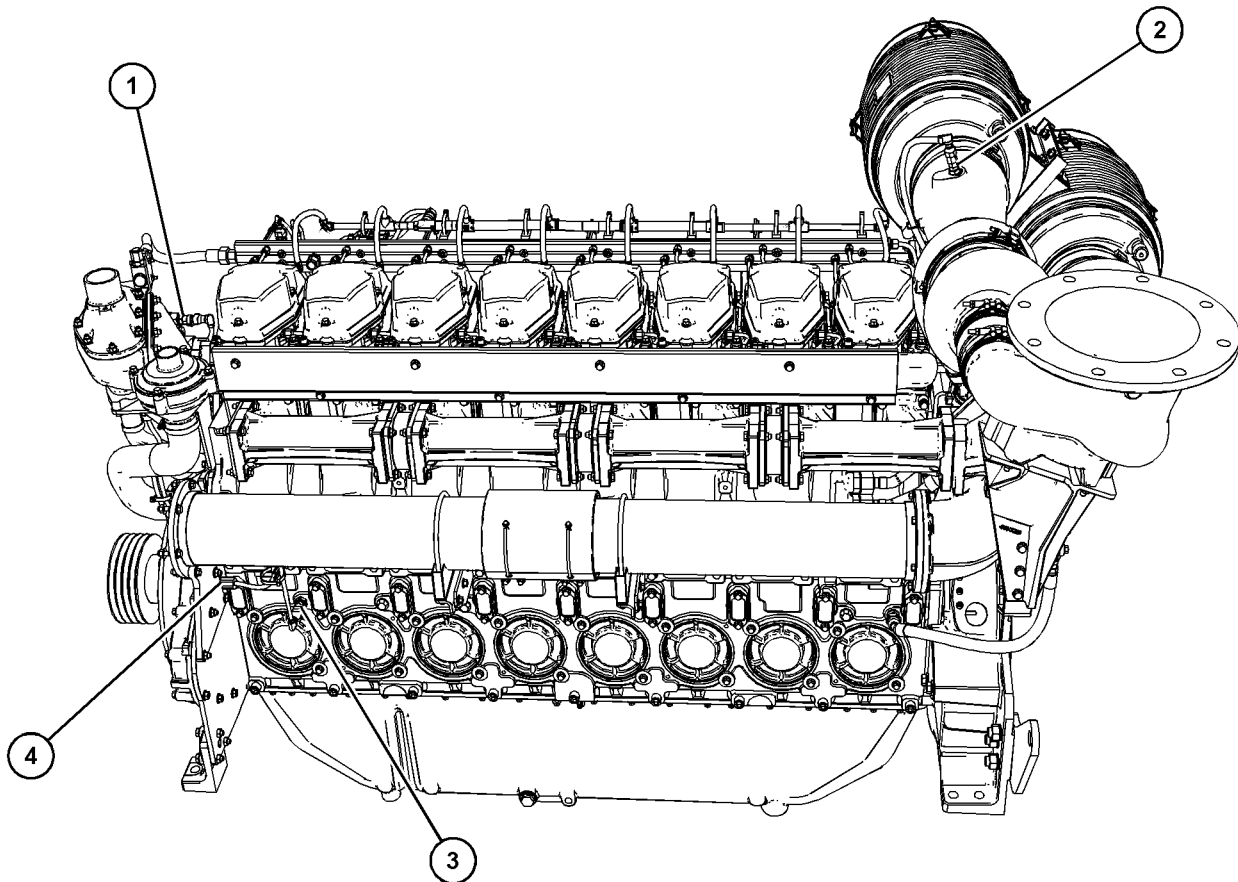

Illustration 42

g06595481

Typical example of an earlier engine

- |                                  |                                  |
|----------------------------------|----------------------------------|
| (1) Coolant temperature sensor   | (3) Oil pressure sensor          |
| (2) Air inlet temperature sensor | (4) Camshaft speed/timing sensor |



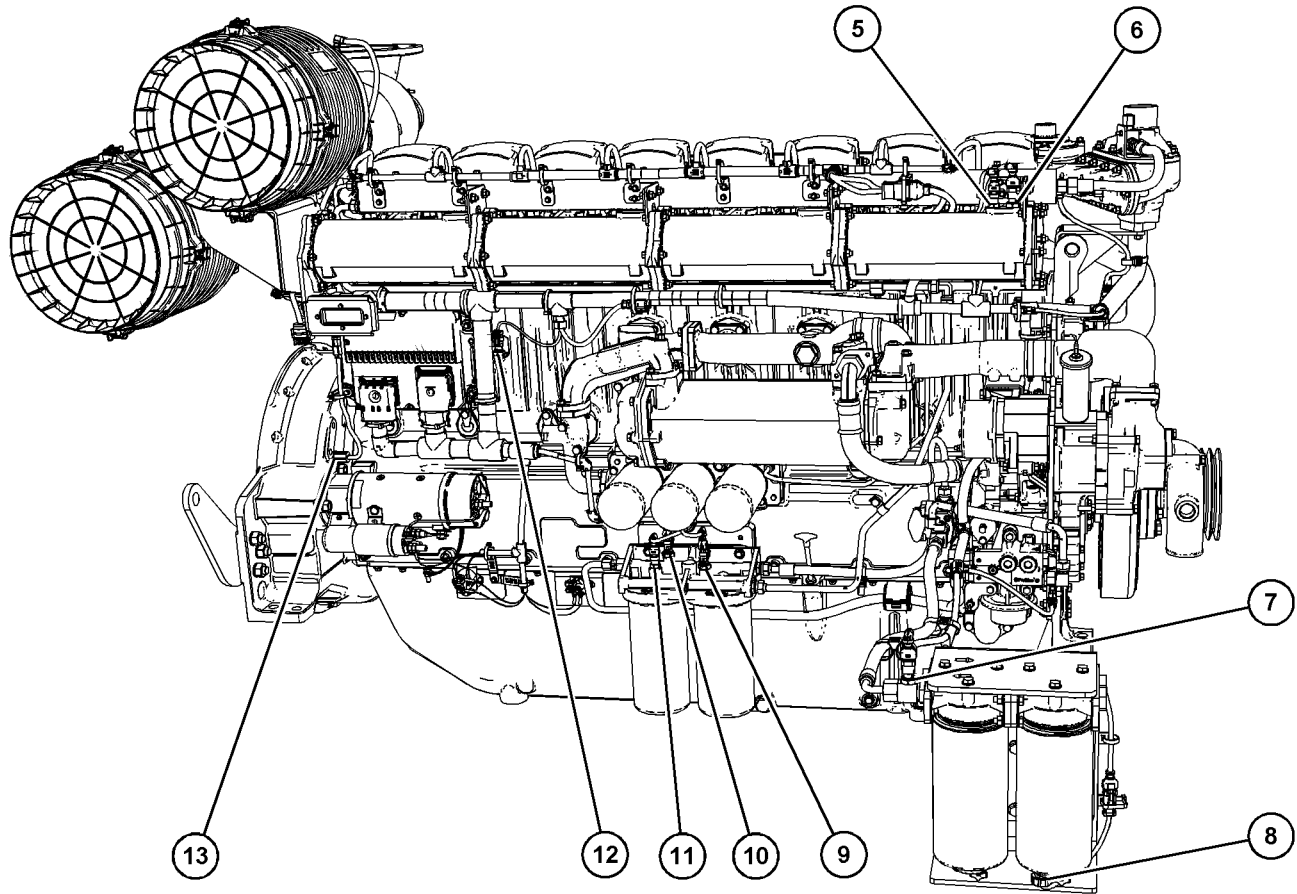

Illustration 43

g06595495

### Typical example of an earlier engine

- |   |  |  |
|---|--|--|
| (5) Inlet manifold temperature sensor               | (9) Fuel pressure sensor after secondary fuel filter   | (12) Barometer pressure sensor (not shown) |
| (6) Inlet manifold pressure sensor                  | (10) Fuel pressure sensor before secondary fuel filter | (13) Flywheel speed/timing sensor          |
| (7) Fuel pressure sensor after primary fuel filters | (11) Fuel temperature sensor                           |  |
| (8) Water In Fuel (WIF) sensor                      |  |  |

## Barometric Pressure Sensor

---

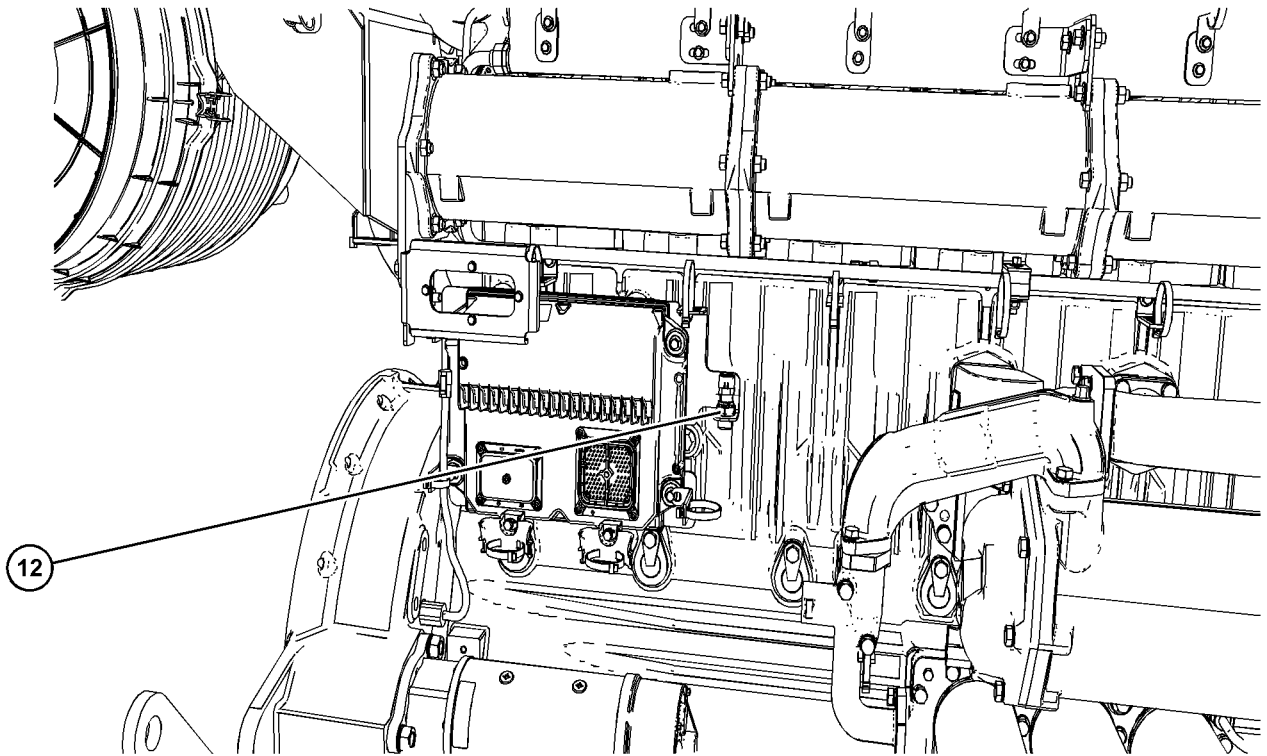

---

Illustration 44

g06595502

Typical example of an earlier engine  
Wiring harness removed for clarity

(12) Barometric pressure sensor

## Later Engine Sensor Views

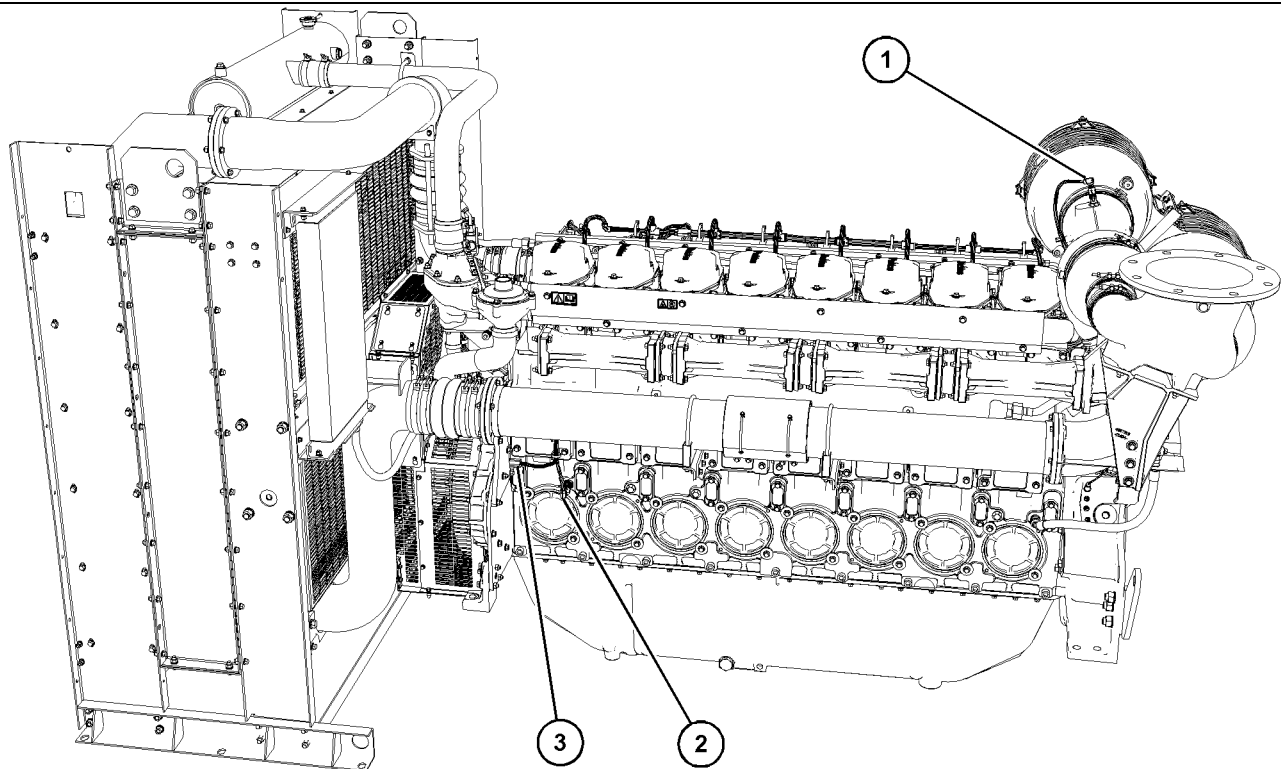

Illustration 45

g07584729

Typical example of a later engine

(1) Air inlet temperature sensor

(2) Oil pressure sensor

(3) Camshaft speed/timing sensor

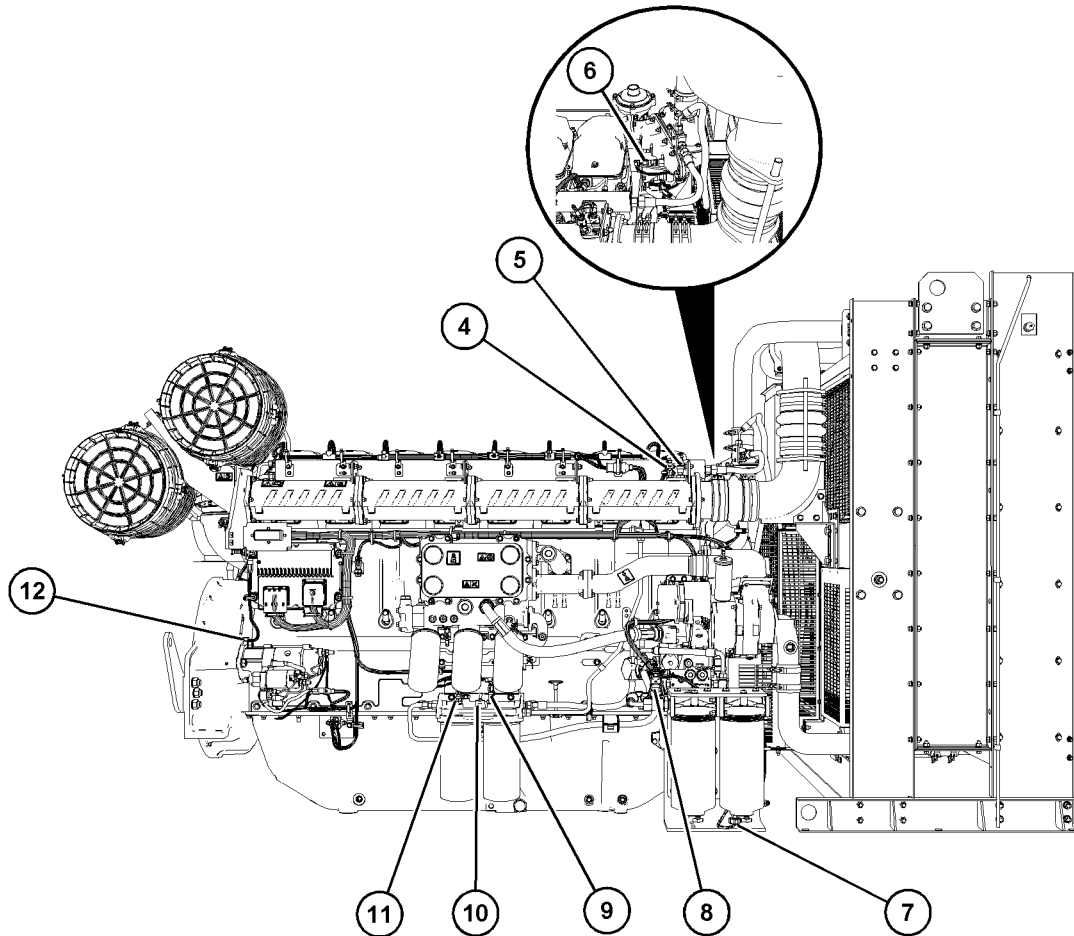

Illustration 46

g07584649

### Typical example of a later engine

- |                                       |  |  |
|---------------------------------------|--|--|
| (4) Inlet manifold temperature sensor | (8) Fuel pressure sensor after primary fuel filters  | (10) Fuel pressure sensor before secondary fuel filter |
| (5) Inlet manifold pressure sensor    | (9) Fuel pressure sensor after secondary fuel filter | (11) Fuel temperature sensor                           |
| (6) Coolant temperature sensor        |  | (12) Flywheel speed/timing sensor                      |
| (7) Water In Fuel (WIF) sensor        |  |  |

## Barometric Pressure Sensor

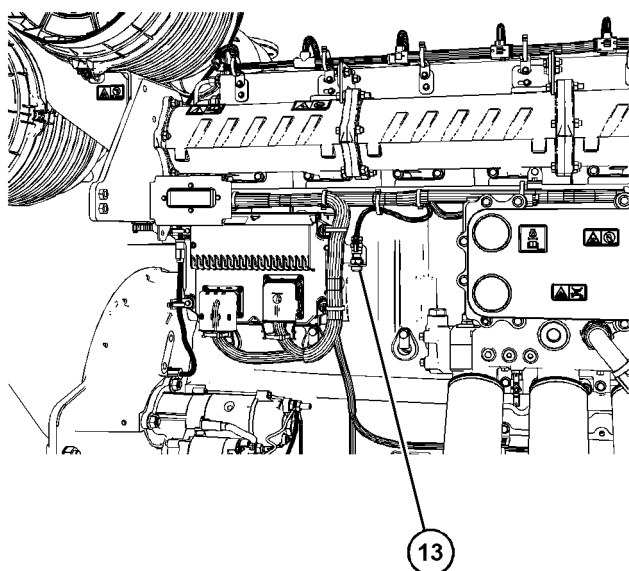

Illustration 47

g07586627

Typical example of a later engine

(13) Barometric pressure sensor

i09769843

## Sensors and Electrical Components (Electrical Components)

The engine view shown is a typical examples only.

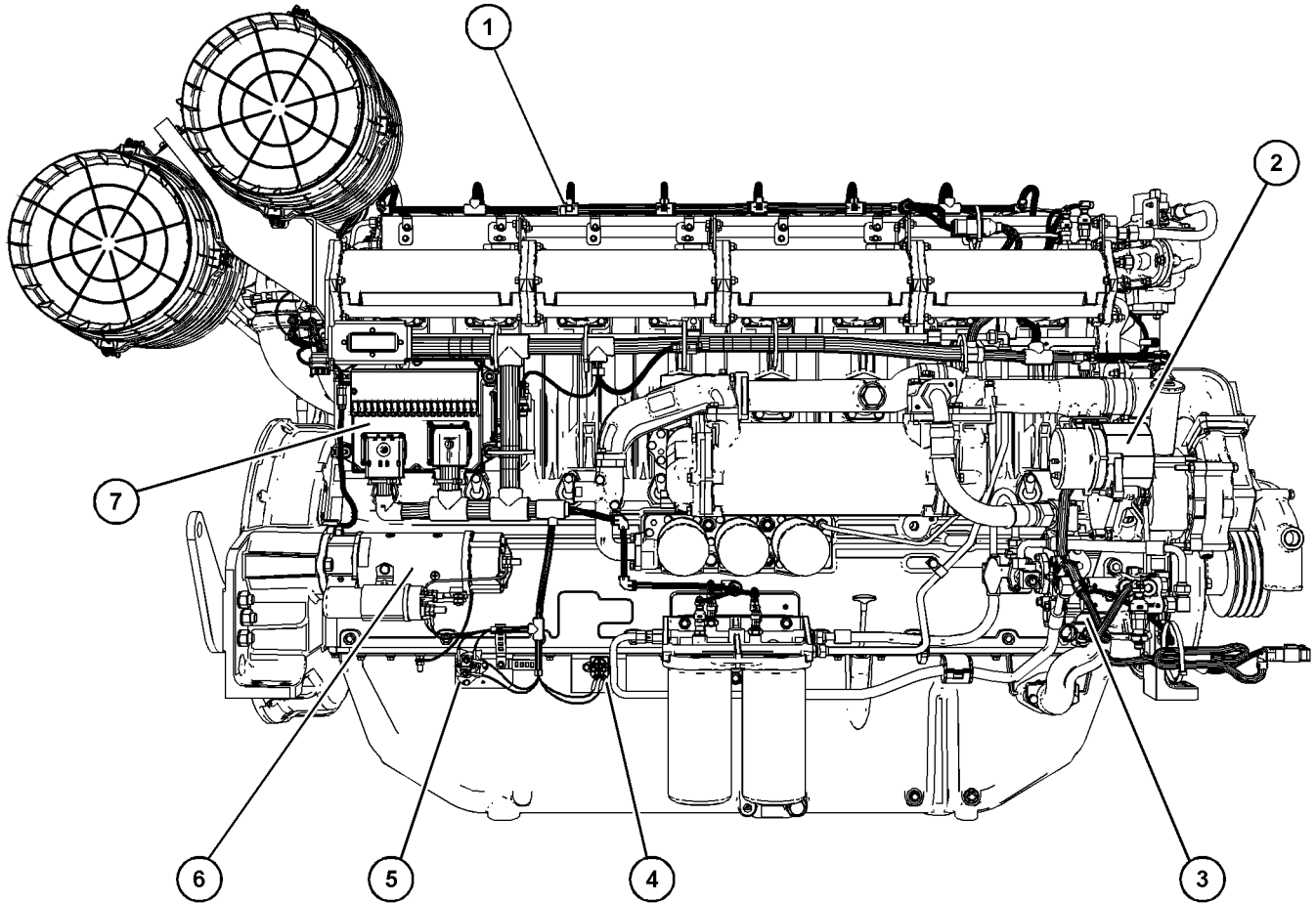

Illustration 48

g06641888

### Typical example of an earlier engine

(1) Injector wiring harness  
(2) Alternator

(3) Electric Priming Pump (EPP) with remote  
switch  
(4) Electric Priming Pump (EPP) relay

(5) Starter relay  
(6) Starting motor  
(7) Electronic Control Module (ECM)

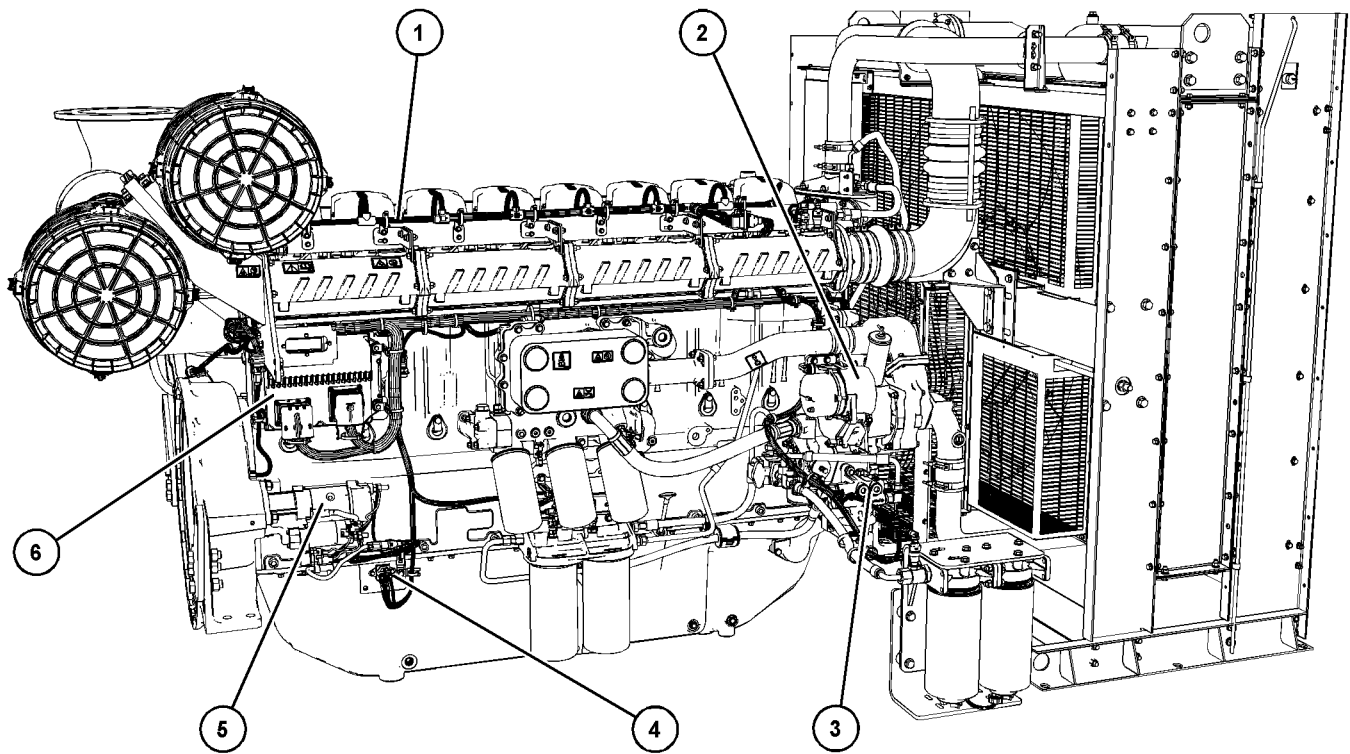

Illustration 49

g07584777

**Typical example of a later engine**

(1) Injector wiring harness  
(2) Alternator

(3) Electric Priming Pump (EPP) with remote  
switch  
(4) Starter relay

(5) Starting motor  
(6) Electronic Control Module (ECM)

# Engine Diagnostics

i01797063

i05194988

## Self-Diagnostics

Perkins Electronic Engines have the capability to perform a self-diagnostics test. When the system detects an active problem, a diagnostic lamp is activated. Diagnostic codes will be stored in permanent memory in the Electronic Control Module (ECM). The diagnostic codes can be retrieved by using Perkins electronic service tools.

Some installations have electronic displays that provide direct readouts of the engine diagnostic codes. Refer to the manual that is provided by the OEM for more information on retrieving engine diagnostic codes.

Active codes represent problems that currently exist. These problems should be investigated first.

Logged codes represent the following items:

- Intermittent problems
- Recorded events
- Performance history

The problems may have been repaired since the logging of the code. These codes do not indicate that a repair is needed. The codes are guides or signals when a situation exists. Codes may be helpful to troubleshoot problems.

When the problems have been corrected, the corresponding logged fault codes should be cleared.

i01902949

## Fault Logging

The system provides the capability of Fault Logging. When the Electronic Control Module (ECM) generates an active diagnostic code, the code will be logged in the memory of the ECM. The codes that have been logged by the ECM can be identified by the electronic service tool. The active codes that have been logged will be cleared when the fault has been rectified or the fault is no longer active. The following logged faults can not be cleared from the memory of the ECM without using a factory password: Overspeed, low engine oil pressure and high engine coolant temperature.

## Engine Operation with Intermittent Diagnostic Codes

If a diagnostic lamp illuminates during normal engine operation and the diagnostic lamp shuts off, an intermittent fault may have occurred. If a fault has occurred, the fault will be logged into the memory of the Electronic Control Module (ECM).

In most cases, it is not necessary to stop the engine because of an intermittent code. However, the operator should retrieve the logged fault codes and the operator should reference the appropriate information in order to identify the nature of the event. The operator should log any observation that could have caused the lamp to light.

- Low power
- Limits of the engine speed
- Excessive smoke, etc

This information can be useful to help troubleshoot the situation. The information can also be used for future reference. For more information on diagnostic codes, refer to the Troubleshooting Guide for this engine.

i06225055

## Configuration Parameters

The engine electronic control module (ECM) has two types of configuration parameters. The system configuration parameters and the customer specified parameters.

The electronic service tool is required in order to alter the configuration parameters.

## System Configuration Parameters

System configuration parameters affect the emissions of the engine or the power of the engine. System configuration parameters are programmed at the factory. Normally, system configuration parameters would never require changing through the life of the engine. System configuration parameters must be reprogrammed if an ECM is replaced. System configuration parameters do not require reprogrammed if the ECM software is changed. Factory passwords are required to change these parameters.

For more information on system configuration parameters and customer specified parameters, refer to Troubleshooting manual.



# Engine Starting

i10198326

## Before Starting Engine

Before the engine is started, perform the required daily maintenance and any other periodic maintenance that is due. Refer to the Operation and Maintenance Manual, "Maintenance Interval Schedule" for more information.

- Do not start the engine or move any of the controls if there is a "DO NOT OPERATE" warning tag or similar warning tag attached to the start switch or to the controls.
- Reset all the shutoffs or alarm components.
- Ensure that any driven equipment has been disengaged. Minimize electrical loads or remove any electrical loads.

1. Open the fuel supply valve (if equipped).
2. If the engine has not been started for several weeks, fuel may have drained from the fuel system. Also, when fuel filters have been changed, some air pockets will be trapped in the engine. In these instances, prime the fuel system. Refer to the Operation and Maintenance Manual, "Fuel System - Prime" for more information.
3. If the engine has not been started for more than 3 months, or the engine oil and filter has been changed, the engine oil system must be primed. Follow Steps 1 through 5 to prime the engine oil system.
4. Apply power to the ECM. Ensure keyswitch is enabled. With the RUN / STOP switch set to the STOP position, crank the engine for 15 seconds. Do not start the engine.
5. Turn the keyswitch to the STOP position.

The engine is now ready to run.

i10198358

## Starting the Engine

### Normal Engine Starting Procedure

**Note:** When possible, ensure that the engine is not started under load.

---

#### NOTICE

Do not engage the starting motor when flywheel is turning.

If the engine fails to start within 15 seconds, release the starter switch or button and wait one minute to allow the starting motor to cool before attempting to start the engine again.

---

1. Apply power to the ECM. Ensure keyswitch is enabled. With the RUN / STOP switch set to the RUN position, crank the engine. Engine should start.
2. If the engine does not start, check for any active fault codes and clear any fault codes that are present, before attempting to start the engine. Repeat step 1.

If the engine does not start after 3 attempts, the ECM will lock out and prevent any further attempts to start the engine.

**Note:** If the engine fails to start after three attempts, investigate the cause.

3. After the engine has started follow Steps 3a through 3d.
  - a. Check the oil pressure.
  - b. Inspect the engine for leaks.
  - c. Ensure that the batteries for the engine are receiving a charge.
  - d. After the engine has run for 5 minutes, check the engine monitoring systems. Ensure that the engine is operating correctly before the load is applied.

### Adaptive Cylinder Cutout and Cranking (ACCC)

If a change in the engine noise is noticed with the engine running, it may be due to the Adaptive Cylinder Cutout and Cranking (ACCC) configuration. ACCC is used to control combustion during cold start, low idle, and low load conditions by only activating selected cylinders during these conditions. ACCC helps maintain consistent power and reduction in white smoke.

ACCC configuration defines cylinder cutout for cold cranking and cold running conditions. This configuration electronically disables cylinder(s), which improves fuel efficiency by controlling the fuel delivery to the injectors. This action does not compromise engine power output.

## Alternative Engine Starting Procedure

**Note:** For a new engine, or when a long block has been obtained and rebuilt in service, or after a major overhaul, Perkins recommends following the procedure below:

**Note:** When possible, ensure that the engine is not started under load.

1. After completion of the installation process, prime the fuel system and the lubricating oil system. Refer to Operation and Maintenance Manual for more information.
  2. Apply power to the ECM. Ensure keyswitch is enabled. With the RUN / STOP switch set to the STOP position, crank the engine for 15 seconds. Do not start the engine.
  3. With the RUN / STOP switch set to the RUN position, crank the engine. The engine should start and operate at the rated speed, operate the engine for 1 minute. The oil pressure will be monitored by the ECM. If the engine oil pressure does not reach the required level, the ECM will log a fault and the engine will stop automatically.
  4. Stop the engine. Inspect the engine for leaks from the fuel, coolant, and lubricating oil systems.
    - a. If no leaks are present, proceed to step 5.
    - b. If leaks are present, repair the leaks. Repeat Step 3 to Step 4.
  5. Start the engine. Operate the engine for 1 minute. Monitor the engine oil pressure. Continue to operate the engine with no load applied for 4 minutes. The total time period for this operation is 5 minutes.
- Note:** After the engine has run for 5 minutes, check the engine monitoring systems. Ensure that the engine is operating correctly before the load is applied.
6. Increase the engine load to 50 percent of prime power over a 60 second time period. Operate the engine for 20 minutes at 50 percent engine load.

7. Increase the engine load to 100 percent of prime power over a 90 second time period. Operate the engine for 20 minutes at 100 percent engine load.
8. Gradually remove all the engine load over a 60 second time period.
9. Operate the engine off load for a time period of 4 minutes to reduce the operating temperature of the engine.
10. Stop the engine. Inspect the engine for leaks from the fuel, coolant, and lubricating oil systems.

i10330283

## Cold Weather Starting

### WARNING

**Do not use aerosol types of starting aids such as ether. Such use could result in an explosion and personal injury.**

Follow the recommendations that are detailed below will improve cold starting and reduce white smoke emissions.

At temperatures below 10 °C (50 °F), a jacket water heater must be installed and operating to maintain a block temperature of 60 °C (140 °F) for applications in North America (USA and Canada) as an aid to starting on low Cetane fuel in these regions. For all other regions the jacket water heater should maintain a temperature of 45 °C (113 °F) to help with starting at temperatures below 10 °C (50 °F).

For engines that operate at 1500 rpm the lower temperature limit with block heater only is -30 °C (-22 °F) and for engines that operate at 1800 rpm, lower temperature limit with block heater is -18 °C (-0.4 °F). For applications installed and operated in temperatures below these lower limits, refer to your Perkins distributor for more information.

For North America (USA and Canada), where a closed-circuit breather system is installed, the supplied heater element must be connected and set to operate in ambient temperatures below 10 °C (50 °F). Operating the heater will prevent freezing within the breather pipes.

No load operation and or multiple start/stop events in colder ambient conditions can cause the emission of white smoke from the exhaust. The emission of white smoke from the exhaust is a result of partly unburnt fuel due to the low cylinder temperatures. No load operation should be avoided and multiple start/stop events kept to a minimum.

Air filters to pull in air from inside the canopy or enclosure, not outside the canopy or enclosure.

Fully charged batteries of the correct capacity.  
Electrical cables that meet the recommended  
specification.

Contact your Perkins distributor or Perkins dealer for  
more information.

# Engine Operation

i02415226

i10199212

## Engine Operation

Correct operation and maintenance are key factors in obtaining the maximum life and economy of the engine. If the directions in the Operation and Maintenance Manual are followed, costs can be minimized and engine service life can be maximized.

The operation of the engine at no load or light load should be avoided or reduced to a minimum period of up to 5 minutes following routine maintenance to ensure that there are no issues following the maintenance. Excessive no load or light load operation of the engine will result in only partly burnt fuel. Partly unburnt fuel will cause high carbon build up on the injector nozzles, cylinder head valves, pistons, and rings.

No load operation and or multiple start/stop events in colder ambient conditions can cause the emission of white smoke from the exhaust, which is a result of partly unburnt fuel due to the low cylinder temperatures. No load operation should be avoided and multiple start/stop events kept to a minimum.

Perkins does not recommend that an engine is operated on loads of less than the values that are listed in Table 3 . Perkins recommends that annual testing is done at the maximum engine rated load for a minimum of 2 hours.

**Note:** Use of a load bank may be required if there is insufficient load.

Table 3

Low Load Running	
Engine Sales Model	Minimum Load (kW)
5006A-E23TA	250 kW (335 hp)
5008A-E30TA, 5008C-E30TA, and 5008AC-E30TA	340 kW (456 hp)

Gauge readings (if equipped) should be observed and the data should be recorded frequently while the engine is operating. Comparing the data over time will help to determine normal readings for each gauge. Comparing data over time will also help detect abnormal operating developments. Significant changes in the readings should be investigated.

## Fuel Conservation Practices

The efficiency of the engine can affect the fuel economy. Perkins design and technology in manufacturing provides maximum fuel efficiency in all applications. Follow the recommended procedures in order to attain optimum performance for the life of the engine.

- Avoid spilling fuel. Fuel expands when the fuel is warmed up. The fuel may overflow from the fuel tank. Inspect fuel lines for leaks. Repair the fuel lines, as needed.
- Be aware of the properties of the different fuels. Use only the recommended fuels.
- Avoid unnecessary running at a low load. If the engine is not under load, the engine should be shut down.
- Observe the air cleaner service indicator frequently. The air cleaner elements should be replaced when the air cleaner elements are dirty.
- Maintain the electrical systems. One damaged battery cell will overwork the alternator. This will consume excess power and excess fuel.
- Ensure that the drive belts are correctly adjusted. The drive belts should be in good condition.
- Ensure that all of the connections of the hoses are tight. The connections should not leak.
- Ensure that the driven equipment is in good working order.
- Cold engines consume excess fuel. Utilize heat from the jacket water system and the exhaust system, when possible. Keep cooling system components clean and keep cooling system components in good repair. Never operate the engine without water temperature regulators. All of these items will help maintain operating temperatures.

# Engine Stopping

i02415227

## Stopping the Engine

**Note:** Individual applications will have different control systems. Ensure that the shutoff procedures are understood. Use the following general guidelines in order to stop the engine.

1. Remove the load from the engine. Allow the engine to run off load for five minutes in order to cool the engine.
2. Stop the engine after the cool down period according to the shutoff system on the engine and turn the ignition key switch to the OFF position. If necessary, refer to the instructions that are provided by the OEM.

i08390557

## Emergency Stopping

### NOTICE

Emergency shutoff controls are for EMERGENCY use ONLY. DO NOT use emergency shutoff devices or controls for normal stopping procedure.

The application should be equipped with an emergency stop button. For more information about the emergency stop button, refer to the OEM information.

Ensure that any components for the external system that support the engine operation are secured after the engine is stopped.

i10016773

## After Stopping Engine

**Note:** Before you check the engine oil, do not operate the engine for at least 10 minutes to allow the engine oil to return to the oil pan.

- If the engine is equipped with a service hour meter, note the reading. Perform the maintenance that is in the Operation and Maintenance Manual, "Maintenance Interval Schedule".
- Check the crankcase oil level. Maintain the oil level between the "MIN" mark and the "MAX" mark on the engine oil level gauge.

- If necessary, perform minor adjustments. Repair any leaks from the low-pressure fuel system and from the cooling, lubrication, or air systems.
- Fill the fuel tank to help prevent accumulation of moisture in the fuel. Do not overfill the fuel tank.
- Discoloration of the fuel can occur in the engine fuel system and is acceptable as long as the fuel meets the specifications in Perkins Diesel Engines Fluids Recommendations, M0113102. Refer to your Perkins distributor for further information.

### NOTICE

Only use antifreeze/coolant mixtures recommended in this Operation and Maintenance Manual, "Refill Capacities and Recommendations" topic or in this Operation and Maintenance Manual, "Fluid Recommendations" topic. Failure to do so can cause engine damage.

### WARNING

**Pressurized System: Hot coolant can cause serious burns. To open the cooling system filler cap, stop the engine and wait until the cooling system components are cool. Loosen the cooling system pressure cap slowly in order to relieve the pressure.**

- Allow the engine to cool. Check the coolant level.
- Check the coolant for correct antifreeze protection and the correct corrosion protection. Add the correct coolant/water mixture, if necessary.
- Perform all required periodic maintenance on all driven equipment. This maintenance is outlined in the instructions from the OEM.

## Cold Weather Operation

i08303869

### Fuel and the Effect from Cold Weather

**Note:** Only use grades of fuel that are recommended by Perkins. Refer to this Operation and Maintenance Manual, “Fluid Recommendations”.

Properties of the diesel fuel can have a significant effect on the engine cold start capability. It is critical that the low temperature properties of diesel fuel are acceptable for the minimum ambient temperature the engine is expected to see in operation.

Following properties are used to define fuels low temperature capability:

- Cloud point
- Pour point
- Cold Filter Plugging Point (CFPP)

The cloud point of the fuel is the temperature at which waxes naturally found in the diesel fuel begin to form crystals. The cloud point of the fuel must be below lowest ambient temperature to prevent filters from plugging.

Pour point is the last temperature before the fuel flow stops and waxing of the fuel will start.

Cold Filter Plugging Point (CFPP) is a temperature at which a particular fuel will pass through a standardized filtration device. This CFPP gives an estimate of the lower operability temperature of fuel

Be aware of these properties when diesel fuel is purchased. Consider the average ambient air temperature for the engines application. Engines that are fueled in one climate may not operate well if the engines are shipped to colder climate. Problems can result due to changes in temperature.

Before troubleshooting for low power or for poor performance in the winter, check the fuel for waxing

The following components can provide a means of minimizing fuel waxing problems in cold weather:

- Fuel heaters, which may be an OEM option
- Fuel line insulation, which may be an OEM option

Winter and arctic grades of diesel fuel are available in the countries and territories with severe winters. For more information refer to the Operation and Maintenance Manual, “Fuel For Cold-Weather Operation”

Another important fuel property which can affect cold start and operation of diesel engine is Cetane number. Detail and requirements of this property are given in this Operation and Maintenance Manual, “Fluid Recommendations”.

i08233444

### Fuel Related Components in Cold Weather

#### Fuel Tanks

Condensation can form in partially filled fuel tanks. Top off the fuel tanks after operating the engine.

Fuel tanks should contain some provision for draining water and sediment from the bottom of the tanks. Some fuel tanks use supply pipes that allow water and sediment to settle below the end of the fuel supply pipe.

Some fuel tanks use supply lines that take fuel directly from the bottom of the tank. If the engine is equipped with this system, regular maintenance of the fuel system filter is important.

Drain the water and sediment from any fuel storage tank at the following intervals:

- Weekly
- Oil changes
- Refueling of the fuel tank

This draining will help prevent water and/or sediment from being pumped from the fuel storage tank and into the engine fuel tank.

#### Fuel Heaters

Fuel heaters help to prevent fuel filters from plugging in cold weather due to waxing. A fuel heater should be installed for the fuel to be heated before the fuel enters the primary fuel filter.

Select a fuel heater that is mechanically simple, yet adequate for the application. The fuel heater should also help to prevent overheating of the fuel. High fuel temperatures reduce engine performance and the availability of engine power. Choose a fuel heater with a large heating surface. The fuel heater should be practical in size. Small heaters can be too hot due to the limited surface area.

Disconnect the fuel heater in warm weather.

**Note:** Fuel heaters that are controlled by the water temperature regulator or self-regulating fuel heaters should be used with this engine. Fuel heaters that are not controlled by the water temperature regulator can heat the fuel in excess of 65° C (149° F). The maximum fuel temperature at the lift pump inlet is 58° C (136.4° F).

**Note:** Heat exchanger type fuel heaters should have a bypass provision to prevent overheating of the fuel in warm-weather operation.

For further information on fuel heaters, consult your Perkins distributor .

# Maintenance Section

## Refill Capacities

i09814892

## Refill Capacities

## Lubrication System

The refill capacities for the engine crankcase reflect the approximate capacity of the crankcase or sump plus standard oil filters. Auxiliary oil filter systems will require more oil. Refer to the Original Equipment Manufacture (OEM) specifications for the capacity of the auxiliary oil filter. Refer to the Operation and Maintenance Manual, "Maintenance Section" for more information on Lubricant Specifications.

Table 4

Engines Refill Capacities			
Engine Sales Model	Compartment or System	Minimum (1)	Maximum (2)
5006-23	Crankcase Oil Sump	100 L (26.4 US gal)	115 L (30.4 US gal)
5008-30	Crankcase Oil Sump	127 L (33.5 US gal)	153 L (40.4 US gal)

(1) These values are the total capacities for the crankcase oil sump which includes the standard factory installed oil filters and oil coolers. Engines with auxiliary oil filters will require more oil. Refer to the OEM specifications for the capacity of the auxiliary oil filter.

(2) Approximate capacity of the largest crankcase oil sump. Refer to OEM for more information.

## Cooling System

Table 5

5006-23 Engine and Engine with Radiator	
Engine Only	36 L (9.5 US gal)
Engine and Radiator	120 L (31.7 US gal)

Table 6

5008-30 Engine and Engine with Radiator	
Engine Only	48 L (12.7 US gal)
Engine and Radiator	140 L (37.0 US gal)

## Fuel System

Refer to the OEM specifications for additional information on the capacity of the fuel system.

i08267149

## Fluid Recommendations (General Coolant Information)

### General Coolant Information

**NOTICE**

Never add coolant to an overheated engine. Engine damage could result. Allow the engine to cool first.

**NOTICE**

If the engine is to be stored in, or shipped to an area with below freezing temperatures, the cooling system must be either protected to the lowest outside temperature or drained completely to prevent damage.

**NOTICE**

Frequently check the specific gravity of the coolant for proper freeze protection or for anti-boil protection.

**NOTICE**

Never operate an engine without water temperature regulators in the cooling system. Water temperature regulators help to maintain the engine coolant at the proper operating temperature. Cooling system problems can develop without water temperature regulators.

Clean the cooling system for the following reasons:

- Contamination of the cooling system
- Overheating of the engine
- Foaming of the coolant

Many engine failures are related to the cooling system. The following problems are related to cooling system failures: Overheating, leakage of the water pump and plugged radiators or heat exchangers.



These failures can be avoided with correct cooling system maintenance. Cooling system maintenance is as important as maintenance of the fuel system and the lubrication system. Quality of the coolant is as important as the quality of the fuel and the lubricating oil.

Coolant is normally composed of three elements: Water, additives, and glycol.

Refer to Perkins Diesel Engines Fluids Recommendations, M0113102 for additional information that relates to coolant.

## Water

### NOTICE

Never use water alone as coolant. Water alone is corrosive and does not provide any protection against boiling or freezing.

Water is used in the cooling system to transfer heat.

**Distilled water or deionized water is recommended for use in engine cooling systems.**

DO NOT use the following types of water in cooling systems: Hard water, softened water that has been conditioned with salt and sea water.

If distilled water or deionized water is not available, use water with the properties that are listed in Table 7 .

Table 7

Perkins Minimum Acceptable Water Requirements		
Property	Maximum Limit	ASTM Test
Chloride (Cl)	40 mg/L	"D4327"
Sulfate (SO <sub>4</sub> )	100 mg/L	"D4327"
Total Hardness	170 mg/L	"D1126"
Total Solids	340 mg/L	"Federal Method 2540B" <sup>(1)</sup>
Acidity	pH of 5.5 to 9.0	"D1293"

<sup>(1)</sup> Total dissolved solids dried at 103° C (217° F) - 105° C (221° F), "Standard Method for the Examination of Water and Wastewater", "American Public Health Association", "www.apha.org", "www.aphabookstore.org", (888) 320-APHA.

For a water analysis, consult one of the following sources:

- Local water utility company
- Agricultural agent
- Independent laboratory

Periodic analysis of water that is used to add to the coolant is recommended. Water quality can be affected by various factors including malfunctioning purification equipment, earthquakes, and droughts.

## Additives

Additives help to protect the metal surfaces of the cooling system. A lack of coolant additives or insufficient amounts of additives enable the following conditions to occur:

- Corrosion
- Formation of mineral deposits
- Rust
- Scale
- Pitting and erosion from cavitation of the cylinder liner
- Foaming of the coolant

Many additives are depleted during engine operation. These additives must be replaced periodically.

Additives must be added at the correct concentration. Over concentration of additives can cause the inhibitors to drop out-of-solution. The deposits can enable the following problems to occur:

- Formation of gel compounds
- Reduction of heat transfer
- Leakage of the water pump seal
- Plugging of radiators, coolers, and small passages

## Glycol

Glycol in the coolant helps to provide protection against the following conditions:

- Boiling
- Freezing
- Cavitation of the water pump

For optimum performance, Perkins recommends a 50 percent by volume of glycol in the finished coolant (also referred to as 1:1 mixture).

**Note:** Use a mixture that will provide protection against the lowest ambient temperature.

**Note:** 100 percent pure glycol will freeze at a temperature of -13 °C (8.6 °F).

Most conventional antifreezes use ethylene glycol. Propylene glycol may also be used. In a 1:1 mixture with water, ethylene and propylene glycol provide similar protection against freezing and boiling. Refer to Table 8 and refer to table 9 .

Table 8

Ethylene Glycol Concentration		
Concentration	Freeze Protection	Boil Protection <sup>(1)</sup>
50 Percent	-37° C (-29° F)	106° C (223° F)
60 Percent	-52° C (-62° F)	111° C (232° F)

<sup>(1)</sup> Boiling protection is increased with the use of a pressurized radiator. A system with a 1 bar (14.5 psi) pressure cap at sea level, will increase the final boiling point of 50 percent coolant to 130° C (266° F).

**NOTICE**

Do not use propylene glycol in concentrations that exceed 50 percent glycol because of the reduced heat transfer capability of propylene glycol. Use ethylene glycol in conditions that require additional protection against boiling or freezing.

Table 9

Propylene Glycol Concentration		
Concentration	Freeze Protection	Boil Protection <sup>(1)</sup>
50 Percent	-32° C (-26° F)	106° C (223° F)

<sup>(1)</sup> Boiling protection is increased with the use of a pressurized radiator. A system with a 1 bar (14.5 psi) pressure cap at sea level, will increase the final boiling point of 50 percent coolant to 130° C (266° F).

Propylene glycol coolant that is used in the cooling systems for Perkins diesel engines must meet "ASTM D6210", "Fully Formulated Glycol-Based Engine Coolant for Heavy-Duty Engines". When propylene glycol coolant is used in heavy-duty diesel engines, a regular addition of SCA is required for protection. Consult your Perkins distributor for additional information.

Ethylene or propylene glycols used in cooling systems for Perkins diesel engines must meet "ASTM E1177", "Standard Specification for Engine Coolant Grade Glycol".

To check the concentration of glycol in the coolant, measure the specific gravity of the coolant.

**Coolant Recommendations**

- ELC \_\_\_\_\_ Extended Life Coolant. A coolant that relies on organic inhibitors for corrosion and cavitation protection. Also known as Organic Acid Technology (OAT) coolant.
- ELI \_\_\_\_\_ Extended Life Inhibitor
- SCA \_\_\_\_\_ Supplement Coolant Additive, concentrated inorganic inhibitor package
- ASTM \_\_\_\_\_ American Society for Testing and Materials

The following three glycol-based coolants are recommended for use in Perkins diesel engines:

**Preferred** – Perkins ELC

**Acceptable** – A commercial heavy-duty antifreeze that meets "ASTM D6210" specifications. Must be replaced after 2 years.

**Adequate** – A commercial heavy-duty antifreeze that meets "ASTM D4985" specifications. Must be replaced after 1 year.

**NOTICE**

**Do not use a commercial coolant/antifreeze that only meets the ASTM D3306 specification. This type of coolant/antifreeze is made for light automotive applications.**

**NOTICE**

A commercial heavy-duty antifreeze that meets "ASTM D4985" specification requires a treatment with an SCA at the initial fill. Read the label or the instructions that are provided by the manufacturer of the product.

**NOTICE**

A commercial heavy-duty antifreeze that meets either "ASTM D4985" or "ASTM D6210" specification requires the SCA concentration to be checked at 500-hour service intervals.

Perkins recommends a 50 percent volume (1:1) glycol and distilled or deionized water of the correct specification. This mixture will provide optimum performance as a coolant/antifreeze. This ratio can be increased to 60 percent volume ethylene glycol to water if extra freezing protection is required.

For applications not requiring freeze protection, the following can be used:

**Preferred** – Perkins ELI

**Acceptable** – A commercial supplemental coolant additive (SCA) that meets "ASTM D5752" specifications.

A mixture of SCA inhibitor and distilled or deionized water is acceptable but will not provide the same level of corrosion, boiling, and freezing protection as ELC or ELI. Perkins recommends a 6 percent to 8 percent concentration of SCA in those cooling systems. Distilled water or deionized water is preferred. Water which has the recommended properties may be used.

i08304120

## Fluid Recommendations (General Fuel Information)

Diesel fuels that meet the Perkins Specification for Distillate Diesel Fuel detailed in the special publication Perkins Diesel Engines Fluids Recommendations, M0113102 are recommended. Fuels meeting the recommended specification will help to provide maximum engine service life and performance. In North America, diesel fuel that is identified as No. 1-D or No. 2-D in "ASTM D975" generally meet the specification requirements.

### NOTICE

Operating with fuels that do not meet Perkins recommendations can cause the following effects: Starting difficulty, poor combustion, deposits in the fuel injectors, reduced service life of the fuel system, deposits in the combustion chamber, and reduced service life of the engine.

Refer to Perkins Diesel Engines Fluids Recommendations, M0113102 for additional information that relates to fuel for your engine.

Consult your local Perkins distributor for additional information on Perkins designed and produced filtration products.

## Refill Capacities for the Fuel System

Refer to the Operation and Maintenance Manual that is provided by the OEM for capacities of the fuel system.

i10199213

## Fluid Recommendations (Engine Oil Specification)

### General Lubricant Information

Because of government regulations regarding the certification of exhaust emissions from the engine, the lubricant recommendations must be followed.

- API \_\_\_\_\_ American Petroleum Institute
- SAE \_\_\_\_\_ Society Of Automotive Engineers Inc.
- ECF \_\_\_\_\_ Engine Crankcase Fluid

### Licensing

The Engine Oil Licensing and Certification System by the American Petroleum Institute (API) is recognized by Perkins. For detailed information about this system, see the latest edition of the "API publication No. 1509". Engine oils that bear the API symbol are authorized by API.

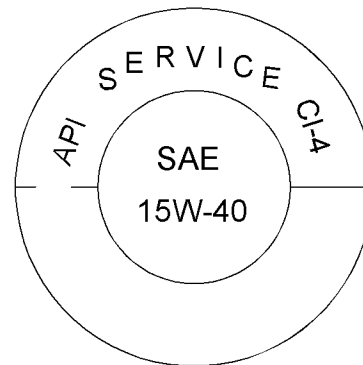

Illustration 50

g03360267

Typical API symbol

### Terminology

Certain abbreviations follow the nomenclature of "SAE J754". Some classifications follow "SAE J183" abbreviations, and some classifications follow the "EMA Recommended Guideline on Diesel Engine Oil". In addition to Perkins definitions, there are other definitions that will be of assistance in purchasing lubricants. Recommended oil viscosities can be found in this publication, "Fluid Recommendations/ Engine Oil Specification" topic (Maintenance Section).

Refer to Perkins Diesel Engines Fluids Recommendations, M0113102 for additional information that relates to oil.

## Engine Oil

### Perkins Diesel Engine Oil

Perkins DEO CI-4 oil is the preferred oil. Perkins multi-grade oil has been developed and tested to provide full performance and service life that has been designed and built into Perkins Engines. Consult your Perkins distributors for more information.

## Commercial Oils

### NOTICE

Perkins require the use of the following specification of engine oil. Failure to use the appropriate specification of engine oil will reduce the life of your engine.

Table 10

Minimum Oil Specification for 5006A-E23TA, 5008A-E30TA, 5008C-E30TA, and 5008AC-E30TA Industrial Engines	
Oil Specification	API CI-4 ECF-2

## Lubricant Viscosity Recommendations for Direct Injection (DI) Diesel Engines

The correct SAE viscosity grade of oil is determined by the minimum ambient temperature during cold engine start-up, and the maximum ambient temperature during engine operation.

Refer to illustration 51 (minimum temperature) to determine the required oil viscosity for starting a cold engine.

Refer to illustration 51 (maximum temperature) to select the oil viscosity for engine operation at the highest ambient temperature that is anticipated.

Generally, use the highest oil viscosity that is available to meet the requirement for the temperature at start-up.

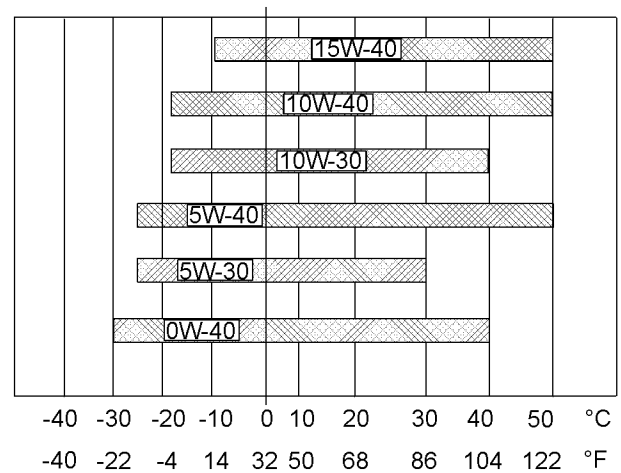

Illustration 51

g03347115

### Lubricant Viscosities

Supplemental heat is recommended for cold soaked starts below the minimum ambient temperature. Supplemental heat may be required for cold soaked starts that are above the minimum temperature that is stated, depending on the parasitic load and other factors. Cold soaked starts occur when the engine has not been operated for a period of time. This interval will allow the oil to become more viscous due to cooler ambient temperatures.

### Aftermarket Oil Additives

Perkins does not recommend the use of aftermarket additives in oil. It is not necessary to use aftermarket additives to achieve the engines maximum service life or rated performance. Fully formulated, finished oils consist of base oils and of commercial additive packages. These additive packages are blended into the base oils at precise percentages to help provide finished oils with performance characteristics that meet industry standards.

There are no industry standard tests that evaluate the performance or the compatibility of aftermarket additives in finished oil. Aftermarket additives may not be compatible with the finished oils additive package, which could lower the performance of the finished oil. The aftermarket additive could fail to mix with the finished oil. This failure could produce sludge in the crankcase. Perkins discourages the use of aftermarket additives in finished oils.

To achieve the best performance from a Perkins engine, conform to the following guidelines:

- See the appropriate "Lubricant Viscosities". Refer to the illustration 51 to find the correct oil viscosity grade for your engine.

- At the specified interval, service the engine. Use new oil and install a new oil filter.
- Perform maintenance at the intervals that are specified in the Operation and Maintenance Manual, “Maintenance Interval Schedule or Fluid Recommendations Fuel Specification”.

## Oil analysis

Some engines may be equipped with an oil sampling valve. If oil analysis is required, the oil sampling valve is used to obtain samples of the engine oil. The oil analysis will complement the preventive maintenance program.

The oil analysis is a diagnostic tool that is used to determine oil performance and component wear rates. Contamination can be identified and measured by using oil analysis. The oil analysis includes the following tests:

- The Wear Rate Analysis monitors the wear of the engines metals. The amount of wear metal and type of wear metal that is in the oil is analyzed. The increase in the rate of engine wear metal in the oil is as important as the quantity of engine wear metal in the oil.

For more information on wear metals, refer to Specifications, “Engine Oil Filter (Extended Oil Service)” or consult your Perkins distributor.

- Tests are conducted to detect contamination of the oil by water, glycol, or fuel.
- The Oil Condition Analysis determines the loss of the oils lubricating properties. An infrared analysis is used to compare the properties of new oil to the properties of the used oil sample. This analysis allows technicians to determine the amount of deterioration of the oil during use. This analysis also allows technicians to verify the performance of the oil according to the specification during the entire oil change interval.
- For more information on extended oil service for diesel engines, contact your Perkins distributor.

# Maintenance Recommendations

i07218310

## Severe Service Application

Severe service is the application of an engine that exceeds the current published standards for that engine. Perkins maintains standards for the following engine parameters:

- Performance such as power range, speed range, and fuel consumption
- Fuel quality
- Operational Altitude
- Maintenance intervals
- Oil selection and maintenance
- Coolant type and maintenance
- Environmental qualities
- Installation
- The temperature of the fluid in the engine

Refer to the standards for the engine or consult your Perkins distributor to determine if the engine is operating within the defined parameters.

Severe service operation can accelerate component wear. Engines that operate under severe conditions may need more frequent maintenance intervals to ensure maximum reliability and retention of full service life.

Perkins engines are unable to identify all the factors which can contribute to severe service operation, due to individual applications. Consult your Perkins dealer or your Perkins distributor for the unique maintenance that is necessary for the engine.

The operating environment, incorrect operating procedures, and incorrect maintenance procedures can be factors which contribute to a severe service application.

## Environmental Factors

**Ambient temperatures** – The engine may be exposed to extended operation in extremely cold environments or hot environments. Valve components can be damaged by carbon buildup if the engine is frequently started and stopped in very cold temperatures. Extremely hot intake air reduces engine performance.

**Quality of the air** – The engine may be exposed to extended operation in an environment that is dirty or dusty, unless the equipment is cleaned regularly. Mud, dirt, and dust can encase components. Maintenance can become very difficult. The buildup can contain corrosive chemicals.

**Buildup** – Compounds, elements, corrosive chemicals, and salt can damage some components.

**Altitude** – Problems can arise when the engine is operated at altitudes that are higher than the intended settings for that application. Necessary adjustments should be made.

## Incorrect Operating Procedures

- Frequent hot shutdowns
- Operating at excessive loads
- Operating at excessive speeds
- Operating outside the intended application

## Incorrect Maintenance Procedures

- Extending the maintenance intervals
- Failure to use recommended fuel, lubricants, and coolant/antifreeze

i10334996

## Maintenance Interval Schedule (50Hz Engines in Standby Applications)

### When Required

“ Battery - Replace“	72
“ Battery Electrolyte Level - Check“	73
“ Battery or Battery Cable - Disconnect“	73
“ Engine - Clean“	90
“ Engine Air Cleaner Element - Replace“	90
“ Engine Mounts - Inspect“	94
“ Engine Oil Sample - Obtain“	97
“ Engine Protective Devices - Check“	99
“ Fuel System - Prime“	101
“ Jacket Water Heater - Check“	115

### Daily or Prior to Starting Stand-by Unit

“ Alternator Pulley - Check“	72
“ Cooling System Coolant Level - Check“	89
“ Driven Equipment - Check“	90
“ Engine Air Cleaner Service Indicator - Inspect“	91
“ Engine Oil Level - Check“	94
“ Fan Drive Pulley - Check“	100
“ Fuel System Primary Filter/Water Separator - Drain“	103
“ Fuel Tank Water and Sediment - Drain“	105
“ Radiator - Clean“	117
“ Walk-Around Inspection“	119

### Initial 750 Service Hours or 2 Years

“ Engine Valve Lash - Inspect/Adjust“	100
---------------------------------------	-----

“ Fuel Injector - Inspect/Adjust“	101
-----------------------------------	-----

### Every 750 Service Hours or 2 Years or Prior to Functional Load Test

“ Aftercooler Core - Clean/Test“	71
“ Aftercooler Core - Inspect“	71
“ Belts - Inspect/Adjust/Replace“	78
“ Belts - Inspect/Adjust/Replace“	73
“ Belts - Inspect/Adjust/Replace“	75
“ Cooling System Coolant Level - Check“	89
“ Crankshaft Vibration Damper - Inspect“	89
“ Engine Air Cleaner Element - Replace“	90
“ Engine Air Cleaner Service Indicator - Inspect“	91
“ Engine Crankcase Breather - Clean“	92
“ Engine Crankcase Breather - Clean/Replace“	92
“ Engine Oil and Filter - Change“	97
“ Engine Oil Level - Check“	94
“ Engine Protective Devices - Check“	99
“ Fuel System Secondary Filter - Replace“	104
“ Hoses and Clamps - Inspect/Replace“	105

### Every 1500 Service Hours

“ Engine Valve Lash - Inspect/Adjust“	100
“ Fuel Injector - Inspect/Adjust“	101

“ Fuel System Primary Filter - Replace“ . . . . . 102

### **Every 2000 Service Hours**

“ Overhaul (Top End)“ . . . . . 116

### **Every 3000 Service Hours**

“ Cooling System Coolant - Change“ . . . . . 84

### **Every 4000 Service Hours**

“ Overhaul (Major)“ . . . . . 115

### **Every 6000 Service Hours or 3 Years**

“ Cooling System Coolant (ELC) - Change“ . . . . . 79

### **Every 7500 Service Hours**

“ Alternator - Inspect“ . . . . . 71

“ Engine Oil Pump - Inspect“ . . . . . 96

“ Fuel Injector - Replace“ . . . . . 101

“ Fuel Transfer Pump (Lift Pump) - Inspect“ . . . . . 105

“ Starting Motor - Inspect“ . . . . . 118

“ Turbocharger - Inspect“ . . . . . 118

“ Water Pump - Inspect“ . . . . . 119



i10335345

# Maintenance Interval Schedule (Engines in Prime Power Applications)

## When Required

- “ Aftercooler Core - Clean/Test“ ..... 71
- “ Aftercooler Core - Inspect“ ..... 71
- “ Battery - Replace“ ..... 72
- “ Battery Electrolyte Level - Check“ ..... 73
- “ Battery or Battery Cable - Disconnect“ ..... 73
- “ Engine - Clean“ ..... 90
- “ Engine Air Cleaner Element - Replace“ ..... 90
- “ Engine Mounts - Inspect“ ..... 94
- “ Engine Oil Sample - Obtain“ ..... 97
- “ Engine Protective Devices - Check“ ..... 99
- “ Fan Drive Pulley - Check“ ..... 100
- “ Fuel Tank Water and Sediment - Drain“ ..... 105
- “ Jacket Water Heater - Check“ ..... 115
- “ Radiator - Clean“ ..... 117
- “ Severe Service Application - Check“ ..... 117

## Daily

- “ Cooling System Coolant Level - Check“ ..... 89
- “ Driven Equipment - Check“ ..... 90
- “ Engine Air Cleaner Service Indicator - Inspect“ .. 91
- “ Engine Oil Level - Check“ ..... 94
- “ Fuel System Primary Filter/Water Separator - Drain“ ..... 103
- “ Walk-Around Inspection“ ..... 119

## Initial 750 Service Hours

- “ Engine Valve Lash - Inspect/Adjust“ ..... 100
- “ Fuel Injector - Inspect/Adjust“ ..... 101

## Every 750 Service Hours

- “ Alternator Pulley - Check“ ..... 72

- “ Belts - Inspect/Adjust/Replace“ ..... 78
- “ Belts - Inspect/Adjust/Replace“ ..... 73
- “ Belts - Inspect/Adjust/Replace“ ..... 75
- “ Crankshaft Vibration Damper - Inspect“ ..... 89
- “ Engine Air Cleaner Element - Replace“ ..... 90
- “ Engine Air Cleaner Service Indicator - Inspect“ .. 91
- “ Engine Crankcase Breather - Clean“ ..... 92
- “ Engine Crankcase Breather - Clean/Replace“ .. 92
- “ Engine Oil and Filter - Change“ ..... 97
- “ Engine Oil Sample - Obtain“ ..... 97
- “ Fan Drive Pulley - Check“ ..... 100
- “ Fuel System Secondary Filter - Replace“ ..... 104
- “ Hoses and Clamps - Inspect/Replace“ ..... 105

## Every 1500 Service Hours

- “ Engine Valve Lash - Inspect/Adjust“ ..... 100
- “ Fuel Injector - Inspect/Adjust“ ..... 101
- “ Fuel System Primary Filter - Replace“ ..... 102

## Every 3000 Service Hours

- “ Cooling System Coolant - Change“ ..... 84

## Every 6000 Service Hours

- “ Cooling System Coolant (ELC) - Change“ ..... 79

## Every 7500 Service Hours

- “ Alternator - Inspect“ ..... 71
- “ Engine Oil Pump - Inspect“ ..... 96
- “ Fuel Injector - Replace“ ..... 101
- “ Fuel Transfer Pump (Lift Pump) - Inspect“ ..... 105
- “ Starting Motor - Inspect“ ..... 118
- “ Turbocharger - Inspect“ ..... 118

“ Water Pump - Inspect“ ..... 119

### **Every 15 000 Service Hours**

“ Overhaul (Top End)“ ..... 116

### **Every 30 000 Service Hours**

“ Overhaul (Major)“ ..... 115

i10334999

# Maintenance Interval Schedule (Engines in Base Load Applications)

## When Required

- “ Aftercooler Core - Clean/Test“ ..... 71
- “ Aftercooler Core - Inspect“ ..... 71
- “ Battery - Replace“ ..... 72
- “ Battery Electrolyte Level - Check“ ..... 73
- “ Battery or Battery Cable - Disconnect“ ..... 73
- “ Engine - Clean“ ..... 90
- “ Engine Air Cleaner Element - Replace“ ..... 90
- “ Engine Mounts - Inspect“ ..... 94
- “ Engine Oil Sample - Obtain“ ..... 97
- “ Engine Protective Devices - Check“ ..... 99
- “ Fan Drive Pulley - Check“ ..... 100
- “ Fuel Tank Water and Sediment - Drain“ ..... 105
- “ Jacket Water Heater - Check“ ..... 115
- “ Radiator - Clean“ ..... 117
- “ Severe Service Application - Check“ ..... 117

## Daily

- “ Cooling System Coolant Level - Check“ ..... 89
- “ Driven Equipment - Check“ ..... 90
- “ Engine Air Cleaner Service Indicator - Inspect“ .. 91
- “ Engine Oil Level - Check“ ..... 94
- “ Fuel System Primary Filter/Water Separator - Drain“ ..... 103
- “ Walk-Around Inspection“ ..... 119

## Initial 750 Service Hours

- “ Engine Valve Lash - Inspect/Adjust“ ..... 100
- “ Fuel Injector - Inspect/Adjust“ ..... 101

## Every 750 Service Hours

- “ Alternator Pulley - Check“ ..... 72

- “ Belts - Inspect/Adjust/Replace“ ..... 78
- “ Belts - Inspect/Adjust/Replace“ ..... 73
- “ Belts - Inspect/Adjust/Replace“ ..... 75
- “ Crankshaft Vibration Damper - Inspect“ ..... 89
- “ Engine Air Cleaner Element - Replace“ ..... 90
- “ Engine Air Cleaner Service Indicator - Inspect“ .. 91
- “ Engine Crankcase Breather - Clean“ ..... 92
- “ Engine Crankcase Breather - Clean/Replace“... 92
- “ Engine Oil and Filter - Change“ ..... 97
- “ Engine Oil Sample - Obtain“ ..... 97
- “ Fan Drive Pulley - Check“ ..... 100
- “ Fuel System Secondary Filter - Replace“ ..... 104
- “ Hoses and Clamps - Inspect/Replace“ ..... 105

## Every 1500 Service Hours

- “ Engine Valve Lash - Inspect/Adjust“ ..... 100
- “ Fuel Injector - Inspect/Adjust“ ..... 101
- “ Fuel System Primary Filter - Replace“ ..... 102

## Every 3000 Service Hours

- “ Cooling System Coolant - Change“ ..... 84

## Every 6000 Service Hours

- “ Cooling System Coolant (ELC) - Change“ ..... 79

## Every 7500 Service Hours

- “ Alternator - Inspect“ ..... 71
- “ Engine Oil Pump - Inspect“ ..... 96
- “ Fuel Injector - Replace“ ..... 101
- “ Fuel Transfer Pump (Lift Pump) - Inspect“ ..... 105
- “ Starting Motor - Inspect“ ..... 118
- “ Turbocharger - Inspect“ ..... 118

“ Water Pump - Inspect“ ..... 119

**Every 20 000 Service Hours**

“ Overhaul (Top End)“ ..... 116

**Every 40 000 Service Hours**

“ Overhaul (Major)“ ..... 115

i10203085

## Maintenance Interval Schedule (60Hz Engines in Standby Applications)

### When Required

“ Battery - Replace”	72
“ Battery Electrolyte Level - Check”	73
“ Battery or Battery Cable - Disconnect”	73
“ Engine - Clean”	90
“ Engine Air Cleaner Element - Replace”	90
“ Engine Mounts - Inspect”	94
“ Engine Oil Sample - Obtain”	97
“ Engine Protective Devices - Check”	99
“ Fuel System - Prime”	101
“ Jacket Water Heater - Check”	115

### Daily or Prior to Starting Stand-by Unit

“ Alternator Pulley - Check”	72
“ Cooling System Coolant Level - Check”	89
“ Driven Equipment - Check”	90
“ Engine Air Cleaner Service Indicator - Inspect”	91
“ Engine Oil Level - Check”	94
“ Fan Drive Pulley - Check”	100
“ Fuel System Primary Filter/Water Separator - Drain”	103
“ Fuel Tank Water and Sediment - Drain”	105
“ Radiator - Clean”	117
“ Walk-Around Inspection”	119

### Initial 250 Service Hours or 1 Year

“ Engine Valve Lash - Inspect/Adjust”	100
---------------------------------------	-----

“ Fuel Injector - Inspect/Adjust”	101
-----------------------------------	-----

### Every 500 Service Hours or 2 Years or Prior to Functional Load Test

“ Aftercooler Core - Clean/Test”	71
“ Aftercooler Core - Inspect”	71
“ Belts - Inspect/Adjust/Replace”	78
“ Belts - Inspect/Adjust/Replace”	73
“ Belts - Inspect/Adjust/Replace”	75
“ Cooling System Coolant Level - Check”	89
“ Crankshaft Vibration Damper - Inspect”	89
“ Engine Air Cleaner Element - Replace”	90
“ Engine Air Cleaner Service Indicator - Inspect”	91
“ Engine Crankcase Breather - Clean”	92
“ Engine Crankcase Breather - Clean/Replace”	92
“ Engine Oil and Filter - Change”	97
“ Engine Oil Level - Check”	94
“ Engine Protective Devices - Check”	99
“ Fuel System Secondary Filter - Replace”	104
“ Hoses and Clamps - Inspect/Replace”	105

### Every 1500 Service Hours

“ Engine Valve Lash - Inspect/Adjust”	100
“ Fuel Injector - Inspect/Adjust”	101

“ Fuel System Primary Filter - Replace“ . . . . . 102

### **Every 2000 Service Hours**

“ Overhaul (Top End)“ . . . . . 116

### **Every 3000 Service Hours**

“ Cooling System Coolant - Change“ . . . . . 84

### **Every 4000 Service Hours**

“ Overhaul (Major)“ . . . . . 115

### **Every 6000 Service Hours or 3 Years**

“ Cooling System Coolant (ELC) - Change“ . . . . . 79

### **Every 7500 Service Hours**

“ Alternator - Inspect“ . . . . . 71

“ Engine Oil Pump - Inspect“ . . . . . 96

“ Fuel Injector - Replace“ . . . . . 101

“ Fuel Transfer Pump (Lift Pump) - Inspect“ . . . . . 105

“ Starting Motor - Inspect“ . . . . . 118

“ Turbocharger - Inspect“ . . . . . 118

“ Walk-Around Inspection“ . . . . . 119

i09727522

## Aftercooler Core - Clean/Test

### WARNING

Personal injury can result from air pressure.

Personal injury can result without following proper procedure. When using pressure air, wear a protective face shield and protective clothing.

Maximum air pressure at the nozzle must be less than 205 kPa (30 psi) for cleaning purposes.

**Note:** The aftercooler is combined with the radiator. The core of the aftercooler cannot be removed. Perkins recommends that the individual uses the most appropriate cleaning method for the application and location. The core may be cleaned with a suitable cleaner. The core must be dry before the engine is operated.

1. Pressurized air is the preferred method for removing loose debris. Direct the air in the opposite direction of the fan's air flow. Hold the nozzle approximately 6 mm (.25 inch) away from the fins. Slowly move the air nozzle in a direction that is parallel with the tubes. This will remove debris that is between the tubes.
2. Pressurized water may also be used for cleaning. The maximum water pressure for cleaning purposes must be less than 275 kPa (40 psi). Use pressurized water to soften mud. Clean the core from both sides.

### NOTICE

Do not use a high concentration of caustic cleaner to clean the core. A high concentration of caustic cleaner can attack the internal metals of the core and cause leakage. Only use the recommended concentration of cleaner.

3. Back flush the aftercooler with a suitable cleaner.
4. Steam clean the aftercooler to remove any residue. Flush the fins of the aftercooler core. Remove any other trapped debris.
5. Wash the aftercooler with hot, soapy water. Rinse the aftercooler thoroughly with clean water.

### WARNING

Personal injury can result from air pressure.

Personal injury can result without following proper procedure. When using pressure air, wear a protective face shield and protective clothing.

Maximum air pressure at the nozzle must be less than 205 kPa (30 psi) for cleaning purposes.

6. Dry the aftercooler with compressed air. Direct the air in the reverse direction of the normal flow. Remove all fluid from the aftercooler. Ensure that the aftercooler is dry.
7. Inspect the aftercooler to ensure cleanliness. Contact your Perkins distributor to pressure test the aftercooler. If necessary, replace the aftercooler. Contact your Perkins distributor for more information.

i06533191

## Aftercooler Core - Inspect

The aftercooler is combined with the radiator, inspect the aftercooler after the radiator and aftercooler has been cleaned.

Inspect the aftercooler for damaged fins, corrosion, dirt, grease, insects, leaves, oil, and other debris. Bent fins may be opened with a "comb". Inspect these items for good condition: Welds, mounting brackets, air lines, connections, clamps, and seals. Make repairs, if necessary.

i07398055

## Alternator - Inspect

Perkins recommends a scheduled inspection of the alternator. Inspect the alternator for loose connections and correct battery charging. Check the ammeter (if equipped) during engine operation in order to ensure correct battery performance and/or correct performance of the electrical system. Make repairs, as required.

Check the alternator and the battery charger for correct operation. If the batteries are correctly charged, the ammeter reading should be very near zero. All batteries should be kept charged. The batteries should be kept warm because temperature affects the cranking power. If the battery is too cold, the battery will not crank the engine. When the engine is not run for long periods of time or if the engine is run for short periods, the batteries may not fully charge. A battery with a low charge will freeze more easily than a battery with a full charge.

i07213693

i02322315

## Alternator Pulley - Check

1. Isolate the electrical supply to the engine. Remove guard cover from alternator. Refer to Operation and Maintenance Manual, Belts- Inspect/Adjust/ Replace (Alternator Belt) for removal of the cover guards.

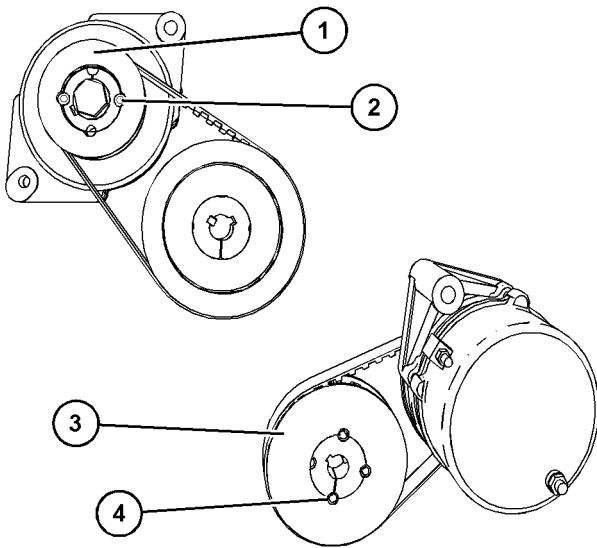

Illustration 52

g06254152

Typical example

2. Check the torque of the lock screws (2) on the alternator pulley (1). Also, Check to torque of the lock screws (4) on the drive pulley (3).
3. The lock screw torque is 20 N·m (177 lb in).
4. Install guard cover to alternator, refer to Operation and Maintenance Manual, Belts- Inspect/Adjust/ Replace (Alternator Belt) for more information.
5. Connect power supply.

## Battery - Replace

### WARNING

Batteries give off combustible gases which can explode. A spark can cause the combustible gases to ignite. This can result in severe personal injury or death.

Ensure proper ventilation for batteries that are in an enclosure. Follow the proper procedures in order to help prevent electrical arcs and/or sparks near batteries. Do not smoke when batteries are serviced.

### WARNING

The battery cables or the batteries should not be removed with the battery cover in place. The battery cover should be removed before any servicing is attempted.

Removing the battery cables or the batteries with the cover in place may cause a battery explosion resulting in personal injury.

1. Switch the engine to the OFF position. Remove all electrical loads.
2. Turn off any battery chargers. Disconnect any battery chargers.
3. The NEGATIVE “-” cable connects the NEGATIVE “-” battery terminal to the NEGATIVE “-” terminal on the starting motor. Disconnect the cable from the NEGATIVE “-” battery terminal.
4. The POSITIVE “+” cable connects the POSITIVE “+” battery terminal to the POSITIVE “+” terminal on the starting motor. Disconnect the cable from the POSITIVE “+” battery terminal.

**Note:** Always recycle a battery. Never discard a battery. Dispose of used batteries to an appropriate recycling facility.

5. Remove the used battery.
6. Install the new battery.

**Note:** Before the cables are connected, ensure that the engine start switch is OFF.

7. Connect the cable from the starting motor to the POSITIVE “+” battery terminal.
8. Connect the NEGATIVE “-” cable to the NEGATIVE “-” battery terminal.



i02747977

i09570426

## Battery Electrolyte Level - Check

When the engine is not run for long periods of time or when the engine is run for short periods, the batteries may not fully recharge. Ensure a full charge in order to help prevent the battery from freezing. If batteries are correctly charged, the ammeter reading should be very near zero, when the engine is in operation.

### WARNING

**All lead-acid batteries contain sulfuric acid which can burn the skin and clothing. Always wear a face shield and protective clothing when working on or near batteries.**

1. Remove the filler caps. Maintain the electrolyte level to the "FULL" mark on the battery.

If the addition of water is necessary, use distilled water. If distilled water is not available use clean water that is low in minerals. Do not use artificially softened water.

2. Check the condition of the electrolyte with a suitable battery tester.
3. Install the caps.
4. Keep the batteries clean.

Clean the battery case with one of the following cleaning solutions:

- Use a solution of 0.1 kg (0.2 lb) baking soda and 1 L (1 qt) of clean water.
- Use a solution of ammonium hydroxide.

Thoroughly rinse the battery case with clean water.

## Battery or Battery Cable - Disconnect

### WARNING

**The battery cables or the batteries should not be removed with the battery cover in place. The battery cover should be removed before any servicing is attempted.**

**Removing the battery cables or the batteries with the cover in place may cause a battery explosion resulting in personal injury.**

1. Turn the start switch to the OFF position. Turn the ignition switch (if equipped) to the OFF position and remove the key and all electrical loads.
2. Open the battery isolator. Disconnect the negative battery terminal. Ensure that the cable cannot contact the terminal. When four 12 volt batteries are involved, two negative connections must be disconnected.
3. Remove the positive connection.
4. Clean all disconnected connection and battery terminals.
5. Use a fine grade of sandpaper to clean the terminals and the cable clamps. Clean the items until the surfaces are bright or shiny. DO NOT remove material excessively. Excessive removal of material can cause the clamps to not fit correctly. Coat the clamps and the terminals with a suitable silicone lubricant or petroleum jelly.
6. Tape the cable connections to help prevent accidental starting.
7. Proceed with necessary system repairs.
8. To connect the battery, connect the positive connection before the negative connection.

i09809769

## Belts - Inspect/Adjust/Replace

### Inspect

To maximize the engine performance, inspect the belts for wear and for cracking. Replace belts that are worn or damaged.

Maintenance Section  
Belts - Inspect/Adjust/Replace

To check accurately the belt tension, a suitable gauge should be used.

1. Isolate the electrical supply to the engine.

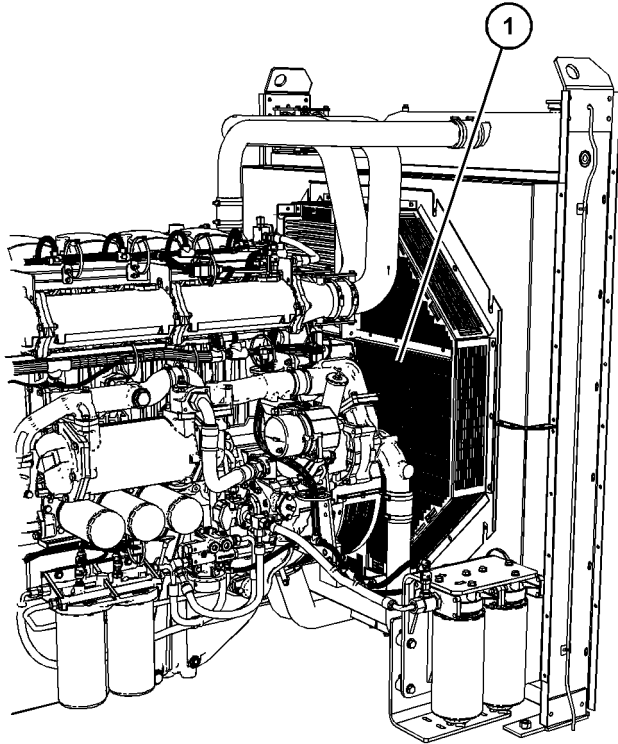

Illustration 53

g06619946

Typical example an earlier engine

2. Visually inspect fan guards for wear or damage. Repair as necessary. Remove the fan guards (1).
3. Inspect the belts for cracks, splits, glazing, grease, displacement of the cord and evidence of fluid contamination. If necessary, replace the belts, refer to "Replace" for more information.

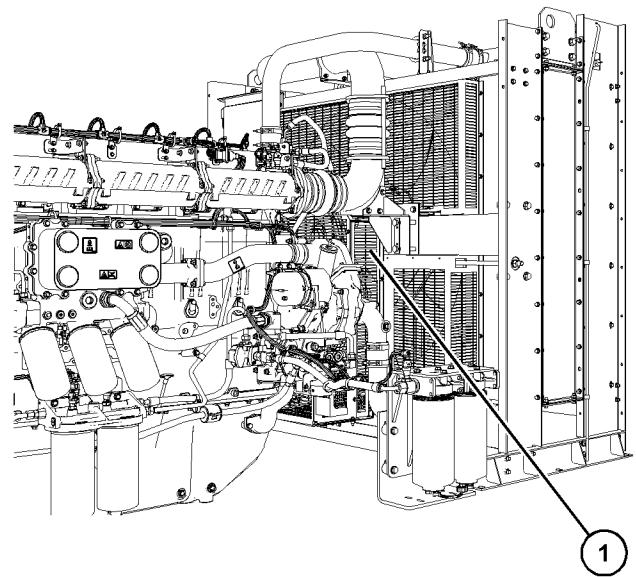

Illustration 54

g07602295

Typical example a later engine

## Adjust

1. Ensure that the electrical supply to the engine is isolated.
2. Using a suitable belt tensioning tool, check the tension of the fan belts. the belt tension should be checked in the middle point between the two pulleys.
  - New belt tension should be set to 49 N (11. lb)
  - Belt tension range should be from 31 N to 49 N (6.9 lb to 11 lb)
  - Belt deflection should be 4.2 mm (0.165 inch)

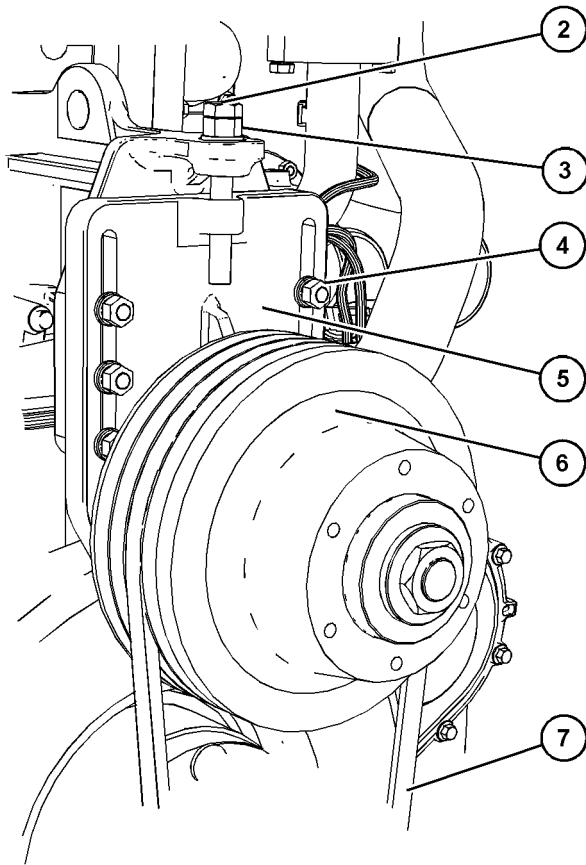

Illustration 55

g06619955

3. Each belt must be checked.
4. Loosen nuts (4) on fan adjuster plate (5). Loosen lock nut (3).
5. Turning bolt (2) counter-clockwise will adjust fan pulley (6) and loosen the fan belts (7).
6. Turning bolt (2) clockwise will adjust fan pulley (6) and tighten the fan belts (7).
7. When the fan belts (7) are at the required tension, tighten nuts (4) to a torque of 85 N·m (62 lb ft). Then, tighten nut (3) securely.

8. Install guards (1) and restore electrical power to the engine.

## Replace

Refer to "Disassembly and Assembly Manual" V-Belts (Fan Drive V-Belts) - Remove and Install for more information.

i09809805

## Belts - Inspect/Adjust/Replace (5008A-E30TA, 5008C-E30TA, and 5008AC-E30TA Engines Only)

### Inspection

1. Isolate the electrical supply to the engine.
2. Visibly inspect fan guards for wear or damage. Repair as necessary.

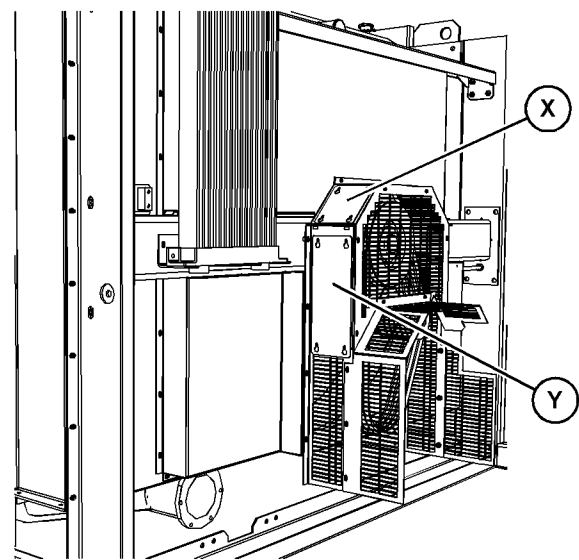

Illustration 56

g06022928

Typical example of an earlier engine

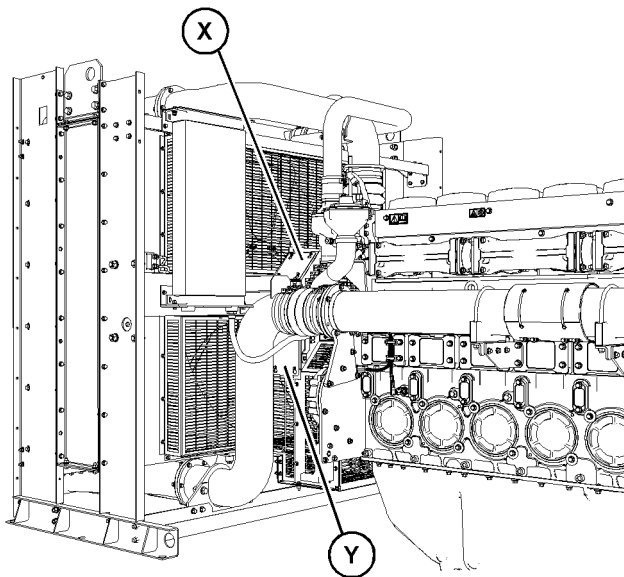

Illustration 57

g07602299

Typical example of a later engine

- Remove the inspection guard (X) and inspection guard (Y).

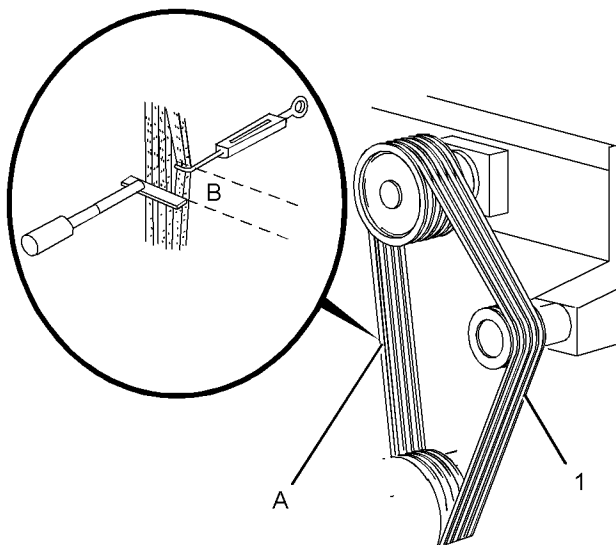

Illustration 58

g02025316

Typical example

- Inspect the belts (1) for cracks. Inspect the belts for contamination. If necessary, replace the belts. Refer to "Replacement" for more information.
- The belt tension must be checked at position A. Use a suitable spring balance and a suitable straight edge to check the belt tension.

- The belt tension should be 62 N (14 lb) with a maximum deflection at position B of 16 mm (0.63 inch).
- Adjust the belts if the belt tension exceeds or is below 62 N (14 lb). Refer to "Adjustment" for more information.
- Install the inspection guard (X) and inspection guard (Y).
- Restore the electrical supply to the engine.

**Note:** Check that the pulleys are securely fitted. Visually check pulleys for angular misalignment, composite misalignment, and axial misalignment. Refer to your Perkins distributor for more information.

## Adjustment

- Ensure that the electrical supply to the engine is isolated. As required, remove the guards.

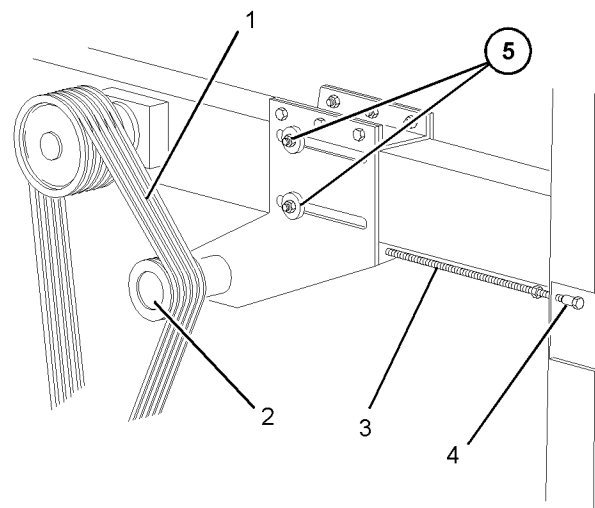

Illustration 59

g06021378

Typical example

- Loosen bolts (5) and loosen the locknut (4).
- Rotate the rod (3) to achieve the correct tension of belts (1). Refer to "Inspection" for the correct specification.
- Tighten the locknut (4) to a torque of 120 N·m (88.5 lb ft). Tighten bolts (5) securely.

5. Ensure that the electrical supply to the engine is isolated. Install the guards.

## Replacement

**Note:** Fan drive belts must be replaced as a set. Do not replace individual belts.

## Removal of the Fan Drive Belts

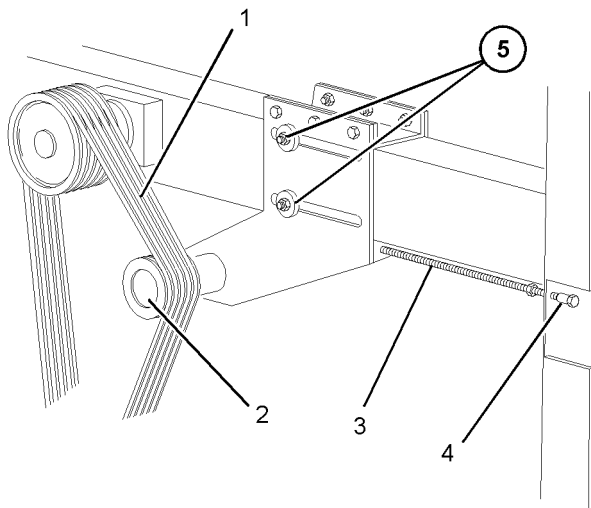

Illustration 60

g06021378

Typical example

1. Ensure that the electrical supply to the engine is isolated. As required, remove the guards.
2. Loosen bolts (5) and loosen the locknut (4).
3. Rotate the rod (3) until the pulley (2) is toward the center of the engine.
4. Remove the belts (1).

## Procedure to Apply the Grease to Fan Drive Assembly and Jockey Pulley

1. Use Shell Alvania RL3 or Shell Gadus S2 V100 3 and apply 8 to 10 grams of grease to the bearings.

**Note:** Each grease gun will be different, so an exercise to determine what the actual gun that is used is delivering will be required. The exercise will ascertain that the correct mass is being used. If a digital delivery system is being used, the grams requirement can be converted to cubic centimeters. For example, 8 to 10 g is equivalent to 40 cc.

2. Use a suitable low-pressure grease gun to pump in the recommended grease.

3. Slowly add the grease to minimize an excessive pressure build-up in the grease cavities.
4. If excessive amounts of grease are pumped into the bearing housing and the old, used grease is not being purged, stop the operation. Check for hardened grease blocking the passages.
5. The grease lines will be visibly full of grease, take care not to overfill. Grease may be seen coming out from the main seals around the shaft, bearing housing as evidence the lines have filled the housing.
6. Rotate the fan drive pulley or the jockey pulley that the grease has been applied to three or four times. Performing this operation ensures that the grease is spread around the internal surfaces of the bearing.
7. If necessary, clean the residual grease from the engine components or the area of the engine or generator set.

## Frequency that the Grease is Applied

Perkins recommends that the grease is applied at the following service intervals:

- For engines in base load and prime power applications - every 500 hours or 1 year
- For engines in standby applications - every 2 years (24 months)

The frequency that the grease is applied may differ depending on the operating ambience. For example, dirty or dusty climates, hot ambient temperatures and prime power applications.

## Installation of the Fan Drive Belts

1. Install new belts (1) over the pulleys.
2. Rotate the rod (3) to achieve an initial tension of 77 N (17 lb). The total deflection should not exceed 16 mm (0.63 inch).
3. Tighten the locknut (4) to a torque of 120 N·m (88.5 lb ft). Tighten bolts (5) securely.
4. Rotate the pulleys for the fan drive belts three to four revolutions to ensure that the fan drive belts are correctly installed. Ensure that the tension is still 77 N (17 lb).
5. Restore the electrical supply to the engine. Install the guards.
6. Operate the engine for 15 to 20 minutes. Refer to Operation and Maintenance Manual, "Starting the Engine" for the correct procedure.

7. Stop the engine. Refer to Operation and Maintenance Manual, "Stopping the Engine" for the correct procedure.
8. Isolate the electrical supply to the engine. Remove the guards.
9. Loosen bolts (5) and loosen the locknut (4).
10. Rotate the rod (3) to achieve a final tension of 62 N (14 lb). The total deflection should not exceed 16 mm (0.63 inch).
11. Tighten the locknut (4) to a torque of 120 N·m (88.5 lb ft). Tighten bolts (5) securely.
12. Restore the electrical supply to the engine. Install the guards.

i10198463

## Belts - Inspect/Adjust/Replace (Alternator Belt)

### Inspection

1. Isolate the electrical supply to the engine.

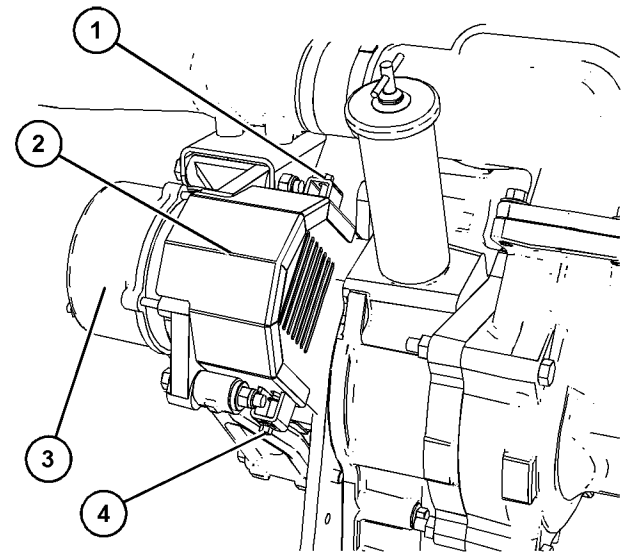

Illustration 61

g06253717

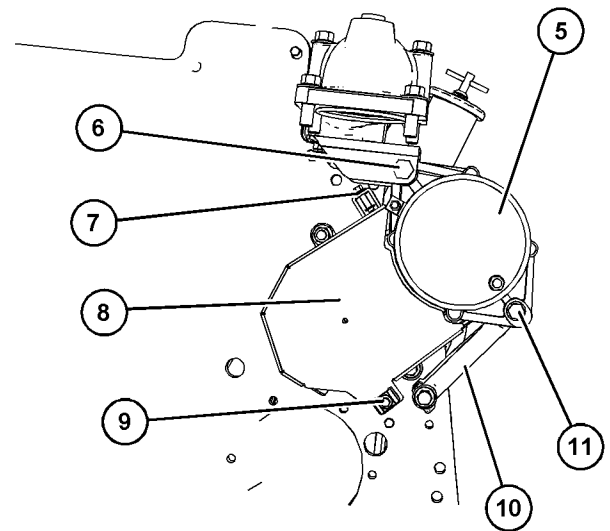

Illustration 62

g06253721

2. Remove bolt (1) and remove bolt (4). Remove top cover (2).
3. Remove bolt (7) and remove bolt (9). Remove lower cover (8).
4. Inspect the belt (13) for cracks. Inspect the belt for contamination. If necessary, replace the belt. Refer to "Replace the Belt" for more information.

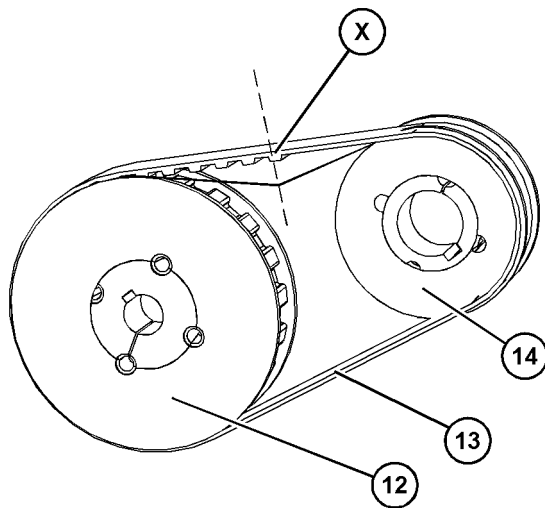

Illustration 63

g06253843

5. Apply 4.3 to 8.7 N (1 to 1.9 lb) of pressure at point (X).

The total deflection should not exceed 2.75 mm (0.10 inch).

Replace the belt if the total deflection exceeds 1.5 mm (0.06 inch). Refer to "Adjustment" for more information.

6. Check that the pulley grub screws are tightened to a torque of 20 N·m (177 lb in).
7. Install lower cover (8) and install top cover (2). Tighten bolt (7) and bolt (9) to a torque of 5 N·m (44.3 lb in). Tighten bolt (4) and bolt (1) to a torque of 5 N·m (44.3 lb in).

## Adjustment

The alternator belt is a toothed belt. The belt tension is not adjustable. The belt does not require a preload. Light tension will ensure that the belt is a snug fit on the pulleys.

## Replace the Belt

Isolate the electrical supply to the engine.

1. Refer to "Inspection" for removing the belt guard covers.
2. Loosen bolt (6) and loosen bolt (11). Push alternator (5) towards engine. If necessary, remove bolt (11) from link (10) to allow more moment.

3. Remove belt (13) and discard. Install new belt and ensure that the belt is located over pulley (12) and pulley (14). Ensure that new toothed belt is located into the pulley (12) and pulley (14).
4. If necessary, install bolt (11) and tension the new belt. Refer to "Inspection" for more information.
5. When required tension is correct, securely tighten bolt (11) and bolt (6). Then, install the cover guards, refer to "Inspection" for more information.

When all checking of the belt or tensioning of the belt are completed and the all guards cover are installed, restore the electrical power.

i10202052

## Cooling System Coolant (ELC) - Change

### NOTICE

Care must be taken to ensure that fluids are contained during performance of inspection, maintenance, testing, adjusting and repair of the product. Be prepared to collect the fluid with suitable containers before opening any compartment or disassembling any component containing fluids.

Dispose of all fluids according to Local regulations and mandates.

### NOTICE

Keep all parts clean from contaminants.

Contaminants may cause rapid wear and shortened component life.

Clean the cooling system and flush the cooling system before the recommended maintenance interval if the following conditions exist:

- The engine overheats frequently.
- Foaming of the coolant is observed.
- The oil has entered the cooling system and the coolant is contaminated.
- The fuel has entered the cooling system and the coolant is contaminated.

**Note:** Refer to Perkins Diesel Engines Fluids Recommendations, Coolant Recommendations (General Maintenance) for more information on the service life of the recommended coolants.

**Note:** When the cooling system is cleaned, only clean water is needed when the Extended Life Coolant (ELC) is drained and replaced.

**Note:** Inspect the water pump and the water temperature regulator after the cooling system has been drained. This inspection is a good opportunity to replace the water pump, the water temperature regulator, and the hoses, if necessary.

## Drain

### WARNING

**Pressurized System:** Hot coolant can cause serious burns. To open the cooling system filler cap, stop the engine and wait until the cooling system components are cool. Loosen the cooling system pressure cap slowly in order to relieve the pressure.

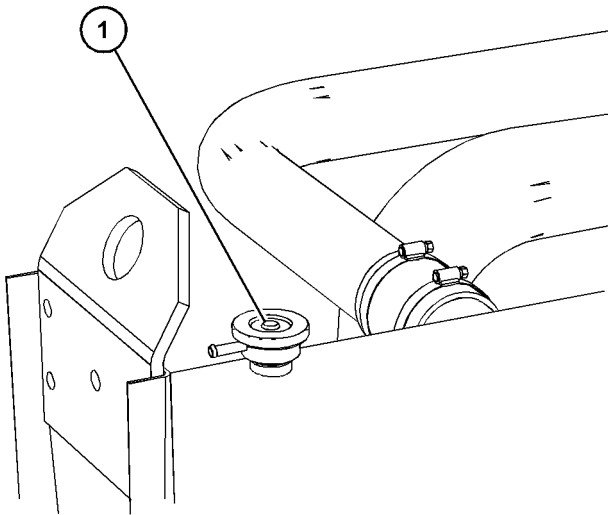

Illustration 64

g06258066

Typical example of an earlier Radiator

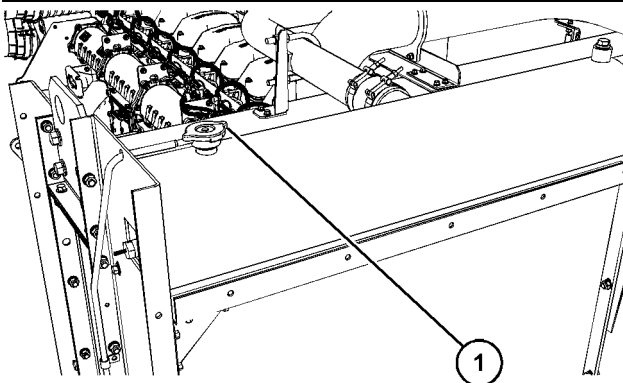

Illustration 65

g07587717

Typical example of a later Radiator

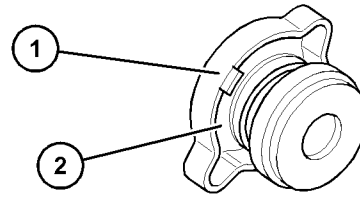

Illustration 66

g06258129

Typical example

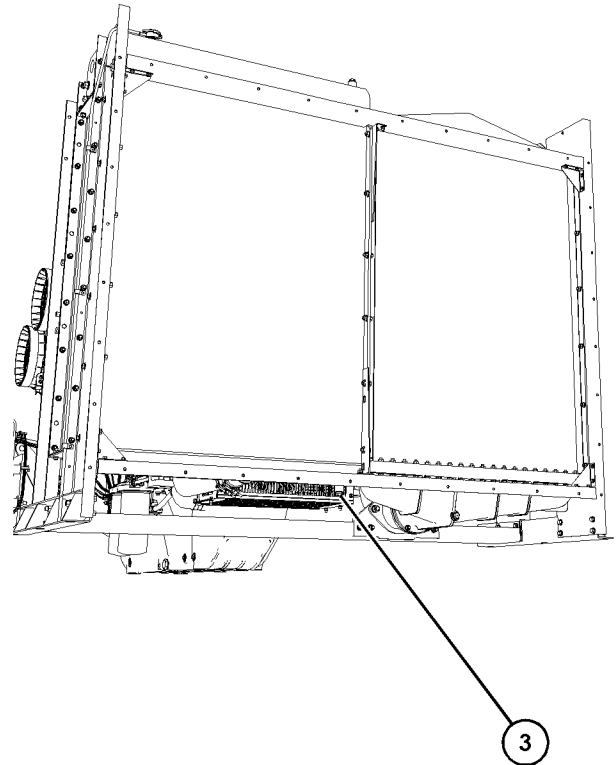

Illustration 67

g07587724

Typical example

1. Stop the engine and allow the engine to cool. Isolate the electrical supply to the engine. Loosen the cooling system filler cap (1) slowly to relieve any pressure. Remove the cooling system filler cap.
2. Clean the cooling system filler cap (1) and inspect the seal (2). If the seal is damaged, discard the old filler cap and install a new filler cap. If the seal is not damaged, use a suitable pressurizing pump to pressure test the filler cap. The correct pressure is stamped on the face of the filler cap. If the filler cap does not retain the correct pressure, replace the filler cap.
3. Open the drain cock or remove the drain plug (3) on the radiator .



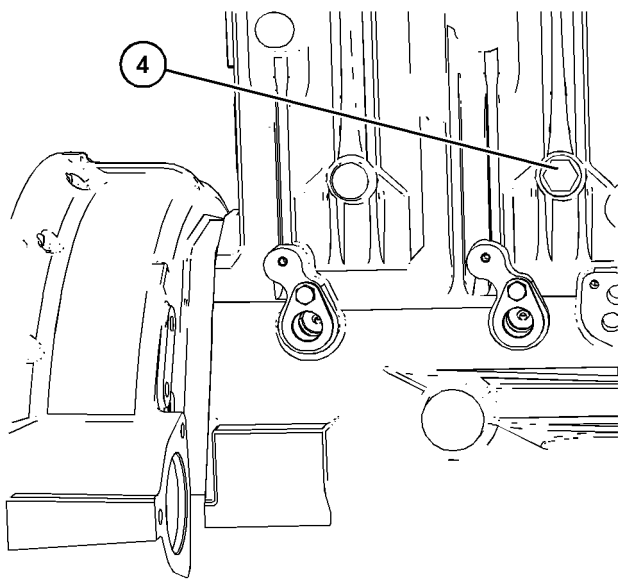

Illustration 68

g06258109

#### 4. Remove the cylinder block drain plug (4).

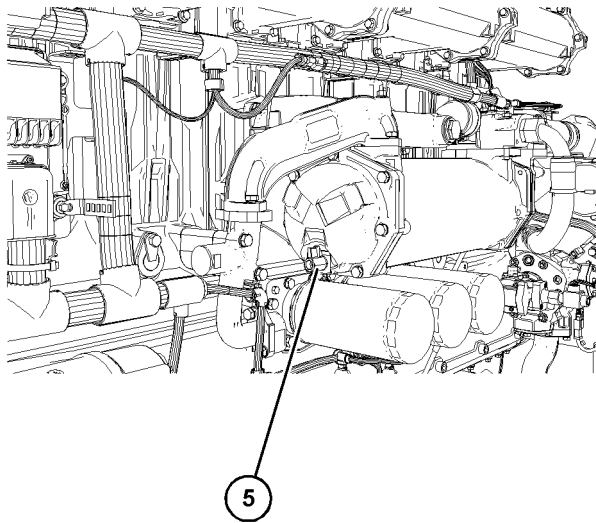

Illustration 69

g06648965

#### Typical example of an earlier engine

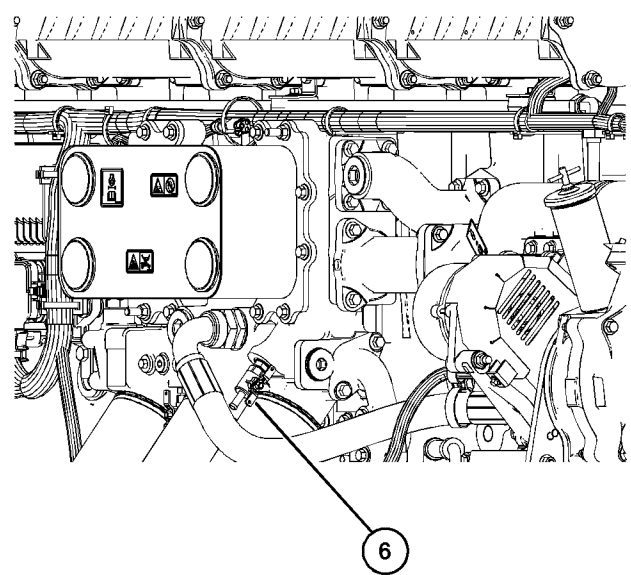

Illustration 70

g07792690

#### Typical example of a later engine

5. Open the drain cock or remove the drain plug (5) in the oil cooler.
6. On later engines, connect a hose to the drain valve (6) on the oil cooler and open the drain cock.
7. Allow the coolant to drain into a suitable container.

#### NOTICE

Dispose of used engine coolant or recycle. Various methods have been proposed to reclaim used coolant for reuse in engine cooling systems. The full distillation procedure is the only method acceptable by Perkins to reclaim the coolant.

For information regarding the disposal and the recycling of used coolant, consult your Perkins distributor.

## Flush

1. Flush the cooling system with clean water to remove any debris.
2. Close the drain cock or install the drain plug (3) on the radiator. Close the drain cock or install the drain plug (4) in the cylinder block. Close the drain cocks or install the drain plug (5) or (6) on the oil cooler. Tighten the plugs securely.

Maintenance Section  
Cooling System Coolant (ELC) - Change

**NOTICE**

Do not fill the cooling system faster than 5 L (1.3 US gal) per minute to avoid air locks.

Cooling system air locks may result in engine damage.

**3. Fill the cooling system with clean water.**

Install the cooling system filler cap (1).

**4. Install power to the engine. Start the engine.**

Operate the engine until the temperature reaches 49 °C to 66 °C (120 °F to 150 °F).

**5. Stop the engine and allow the engine to cool.**

Isolate the electrical supply to the engine. Loosen the cooling system filler cap (1) slowly to relieve any pressure. Remove the cooling system filler cap. Open the drain cock or remove the drain plug (3) on the radiator. Open the drain cock or remove the drain plug (4) in the cylinder block. Open the drain cock or remove the drain plug (5) or (6) on the oil cooler. Allow the water to drain. Flush the cooling system with clean water.

## Filling from top of the Radiator

**1. Close the drain cock or install the drain plug (3) on the radiator. Close the drain cock or install the drain plug (4) in the cylinder block.**

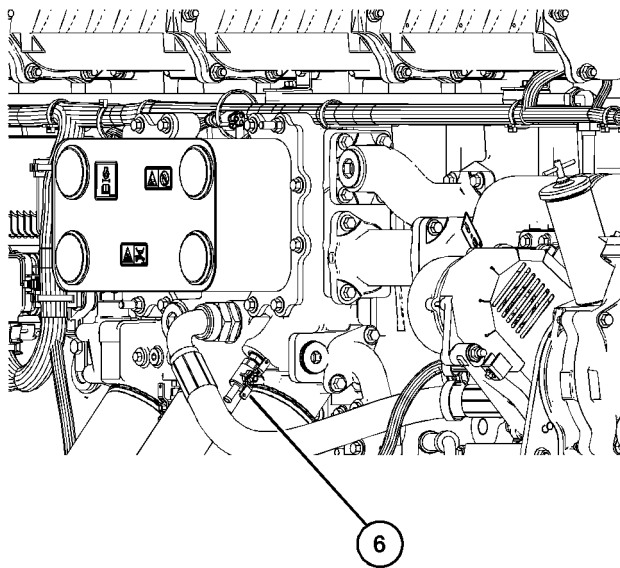

Illustration 71

g07792690

Typical example of a later engine

**2. Open the drain cock (6) on the engine oil cooler to allow air in the cooling system to vent to avoid air locks during filling.**

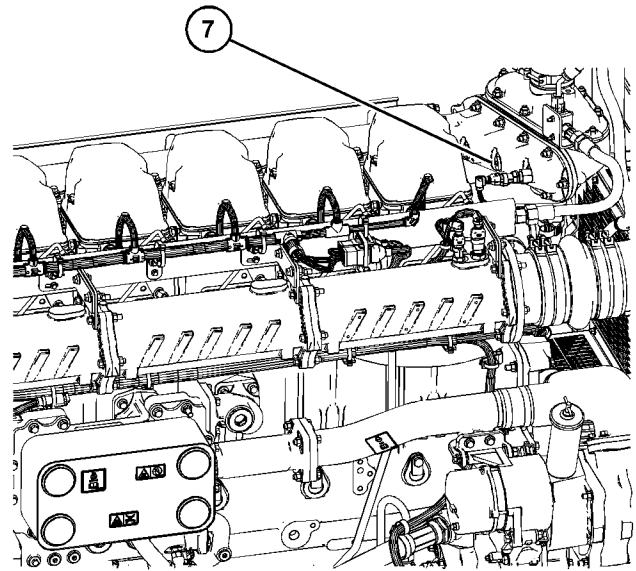

Illustration 72

g07792418

Typical example of a later engine

**3. Loosen the plug (7) on the water temperature regulator to allow air in the cooling system to vent to avoid air locks during filling.**

**NOTICE**

Do not fill the cooling system faster than 5 L (1.3 US gal) per minute to avoid air locks.

Cooling system air locks may result in engine damage.

**4. Fill the cooling system with Perkins ELC. Refer to the Operation and Maintenance Manual, "Fluid Recommendations" topic (Maintenance Section) for more information on cooling system specifications.**

**5. When coolant starts leaking from the cock (6), close the cock and continue to fill the cooling system.**

**6. When coolant starts leaking from the plug (7), securely tighten the plug and continue to fill until the cooling system is full.**

**Note:** Ensure that the filler cap is installed before operating the engine.

**7. Install power to the engine. Start the engine. Operate the engine to purge the air from the cavities of the engine block. Use the normal shutdown procedure to stop the engine.**

**8. Isolate the electrical supply to the engine. Remove the filler cap. Check that the coolant level is within 25 mm (1.0 inch) of the bottom of the filler pipe.**

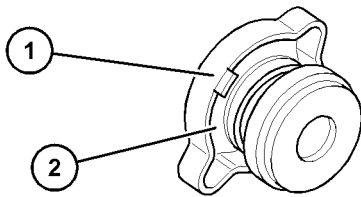

Illustration 73

g06258129

9. Clean the cooling system filler cap (1) and inspect the seal (2). If the seal is damaged, discard the old filler cap and install a new filler cap. If the seal is not damaged, use a suitable pressurizing pump to pressure test the filler cap. The correct pressure is stamped on the face of the filler cap. If the filler cap does not retain the correct pressure, replace the filler cap.

Install the cooling system filler cap.

10. Install power to the engine. Start the engine. Operate the engine. Inspect the cooling system for leaks. Ensure that the cooling system operates at the correct temperature.

## Fill using a pump

1. Close the drain cock or install the drain plug (4) in the cylinder block.
2. On the radiator drain point, install a suitable adaptor / pipe / tap to connect a pump "(1/4 BSP)".

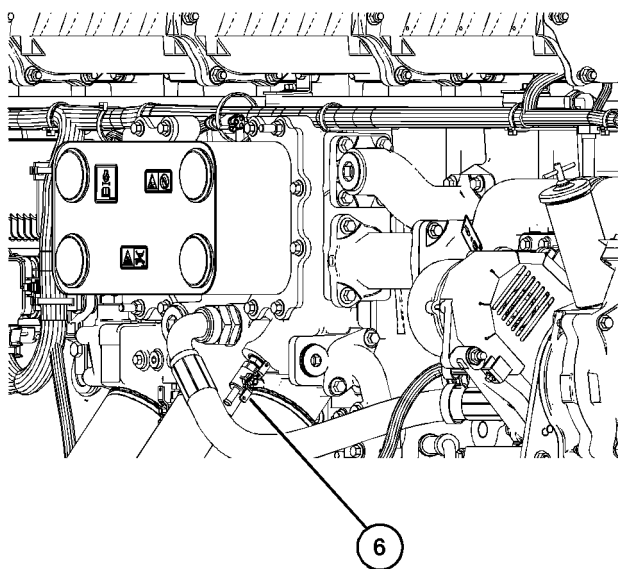

Illustration 74

g07792690

Typical example of a later engine

3. Open the drain cock (6) on the engine oil cooler to allow air in the cooling system to vent to avoid air locks during filling.

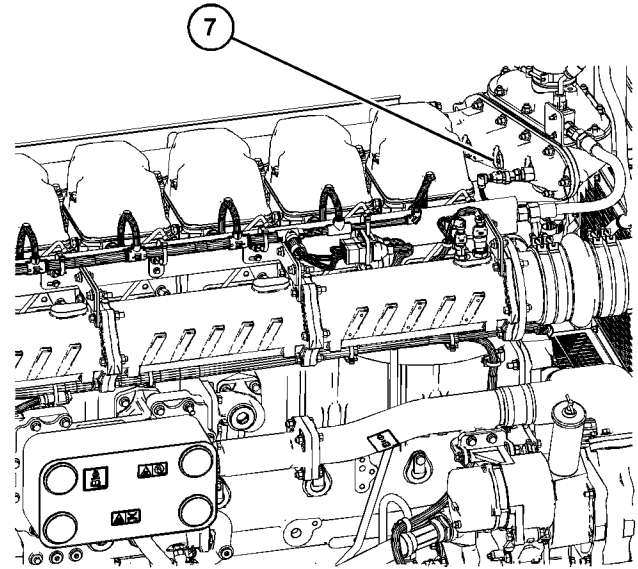

Illustration 75

g07792418

Typical example of a later engine

4. Loosen the plug (7) on the water temperature regulator to allow air in the cooling system to vent to avoid air locks during filling.

### NOTICE

Do not fill the cooling system faster than 5 L (1.3 US gal) per minute to avoid air locks.

Cooling system air locks may result in engine damage.

5. Using a pump, fill the cooling system with Perkins ELC. Refer to the Operation and Maintenance Manual, "Fluid Recommendations" topic (Maintenance Section) for more information on cooling system specifications.
6. When coolant starts leaking from the cock (6), close the cock and continue to fill the cooling system.
7. When coolant starts leaking from the plug (7) securely tighten the plug and continue to fill until the cooling system is full.

**Note:** Ensure that the filler cap is installed before operating the engine.

8. Install power to the engine. Start the engine. Operate the engine to purge the air from the cavities of the engine block. Use the normal shutdown procedure to stop the engine.

Maintenance Section  
Cooling System Coolant - Change

9. Isolate the electrical supply to the engine. Remove the filler cap. Check that the coolant level is within 25 mm (1.0 inch) of the bottom of the filler pipe.

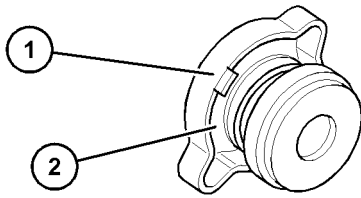

Illustration 76

g06258129

10. Clean the cooling system filler cap (1) and inspect the seal (2). If the seal is damaged, discard the old filler cap and install a new filler cap. If the seal is not damaged, use a suitable pressurizing pump to pressure test the filler cap. The correct pressure is stamped on the face of the filler cap. If the filler cap does not retain the correct pressure, replace the filler cap.

Install the cooling system filler cap.

11. Install power to the engine. Start the engine. Operate the engine. Inspect the cooling system for leaks. Ensure that the cooling system operates at the correct temperature.

i10202029

## Cooling System Coolant - Change

### NOTICE

Care must be taken to ensure that fluids are contained during performance of inspection, maintenance, testing, adjusting and repair of the product. Be prepared to collect the fluid with suitable containers before opening any compartment or disassembling any component containing fluids.

Dispose of all fluids according to Local regulations and mandates.

### NOTICE

Keep all parts clean from contaminants.

Contaminants may cause rapid wear and shortened component life.

Clean the cooling system and flush the cooling system before the recommended maintenance interval if the following conditions exist:

- The engine overheats frequently.

- Foaming of the coolant is observed.
- The oil has entered the cooling system and the coolant is contaminated.
- The fuel has entered the cooling system and the coolant is contaminated.

**Note:** Refer to Perkins Diesel Engines Fluids Recommendations, Coolant Recommendations (General Maintenance) for more information on the service life of the recommended coolants.

**Note:** When the cooling system is cleaned, only clean water is needed when the coolant is drained and replaced.

**Note:** Inspect the water pumps and the water temperature regulators after the cooling system has been drained. This is a good opportunity to replace the water pumps, the water temperature regulators and the hoses, if necessary.

## Drain

### WARNING

**Pressurized System: Hot coolant can cause serious burns. To open the cooling system filler cap, stop the engine and wait until the cooling system components are cool. Loosen the cooling system pressure cap slowly in order to relieve the pressure.**

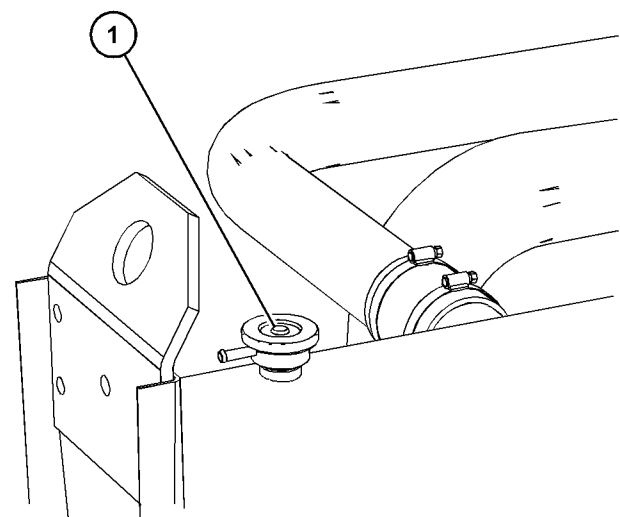

Illustration 77

g06258066

Typical example of an earlier Radiator

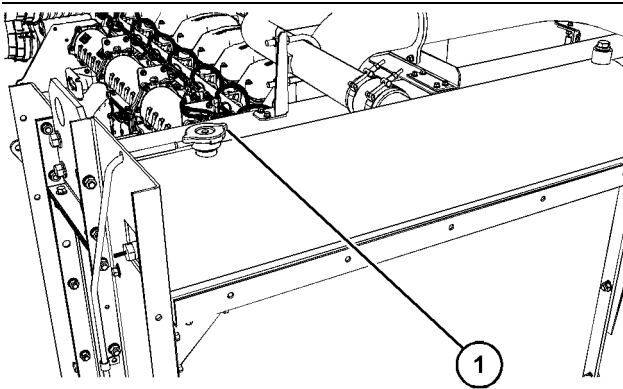

Illustration 78

g07587717

Typical example of a later Radiator

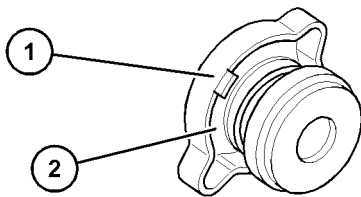

Illustration 79

g06258129

Typical example

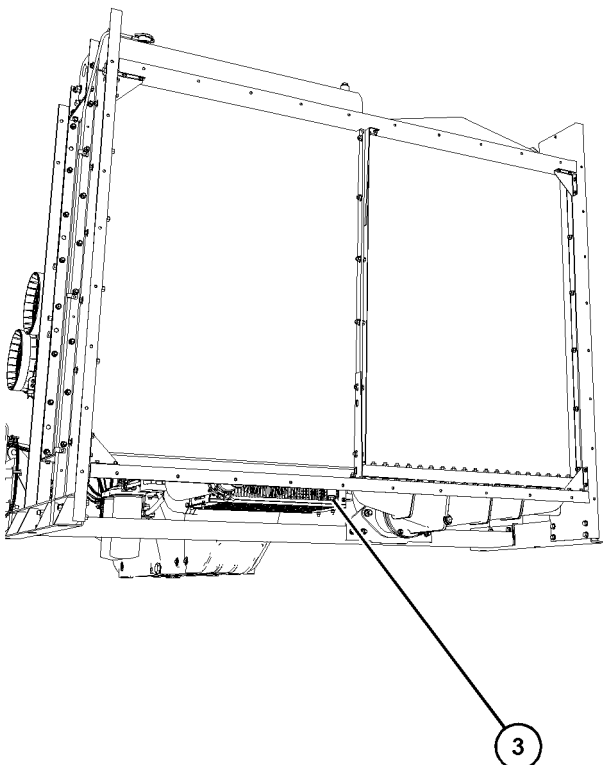

Illustration 80

g07587724

Typical example

1. Stop the engine and allow the engine to cool. Isolate the electrical supply to the engine. Loosen the cooling system filler cap (1) slowly to relieve any pressure. Remove the cooling system filler cap.
2. Clean the cooling system filler cap (1) and inspect the seal (2). If the seal is damaged, discard the old filler cap and install a new filler cap. If the seal is not damaged, use a suitable pressurizing pump to pressure test the filler cap. The correct pressure is stamped on the face of the filler cap. If the filler cap does not retain the correct pressure, replace the filler cap.
3. Open the drain cock or remove the drain plug (3) on the radiator.

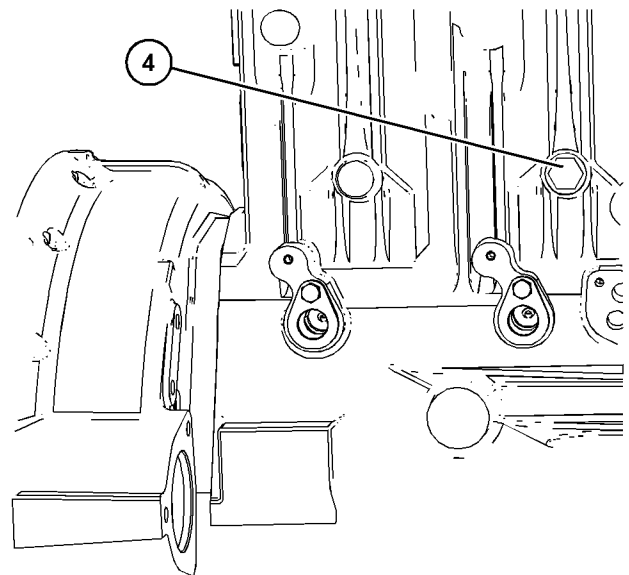

Illustration 81

g06258109

4. Remove the cylinder block drain plug (4).

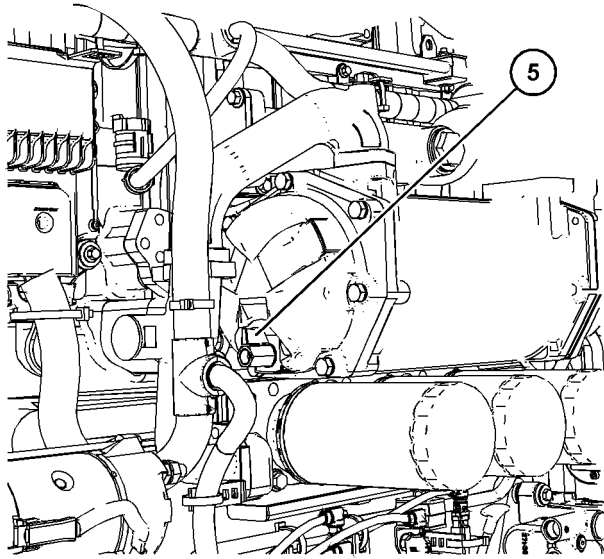

Illustration 82

g06258120

Typical example of an earlier engine

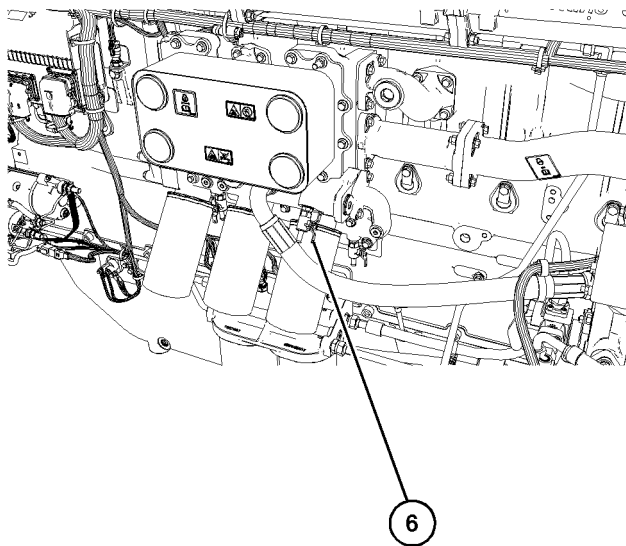

Illustration 83

g07587758

Typical example of a later engine

5. Open the drain cock or remove the drain plug (5) in the oil cooler.
6. On later engines, connect a hose to the drain valve (6) on the oil cooler and open the drain cock.
7. Allow the coolant to drain into a suitable container.

#### NOTICE

Dispose of all fluids according to local regulations and mandates. When you recycle used engine coolant for reuse in engine cooling systems, the full distillation procedure is the only method acceptable by Perkins Engines Company LTD to reclaim the coolant.

For information regarding the disposal and the recycling of used coolant, consult your Perkins distributor.

### Flush

1. Flush the cooling system with clean water to remove any debris.
2. Close the drain cock or install the drain plug (3) on the radiator. Close the drain cock or install the drain plug (4) in the cylinder block. Close the drain cocks or install the drain plug (5) or (6) on the oil cooler. Tighten the plugs securely.

#### NOTICE

Do not fill the cooling system faster than 5 L (1.3 US gal) per minute to avoid air locks.

Cooling system air locks may result in engine damage.

3. Fill the cooling system with clean water.
  - Install the cooling system filler cap (1)
4. Install power to the engine. Start the engine. Operate the engine until the temperature reaches 49 °C to 66 °C (120 °F to 150 °F).
5. Stop the engine and allow the engine to cool. Isolate the electrical supply to the engine. Loosen the cooling system filler cap (1) slowly to relieve any pressure. Remove the cooling system filler cap. Open the drain cock or remove the drain plug (3) on the radiator. Open the drain cock or remove the drain plug (4) in the cylinder block. Open the drain cock or remove the drain plug (5) or (6) on the oil cooler. Allow the water to drain. Flush the cooling system with clean water.

### Filling from top of the Radiator

1. Close the drain cock or install the drain plug (3) on the radiator. Close the drain cock or install the drain plug (4) in the cylinder block.

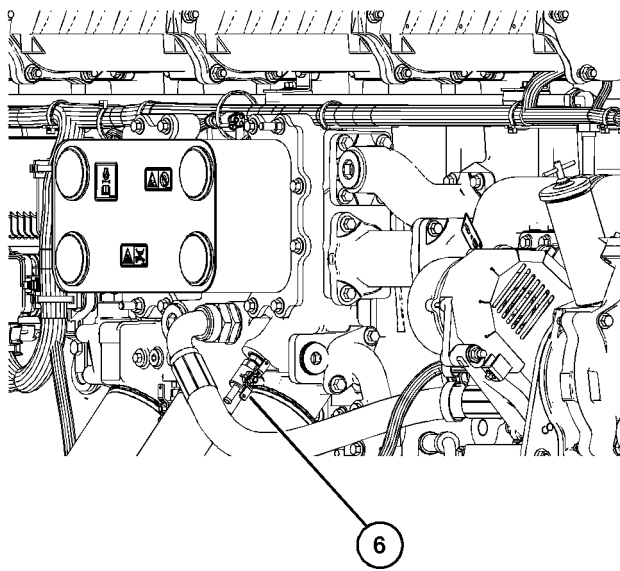

Illustration 84

g07792690

Typical example of a later engine

- Open the drain cock (6) on the engine oil cooler to allow air in the cooling system to vent to avoid air locks during filling.

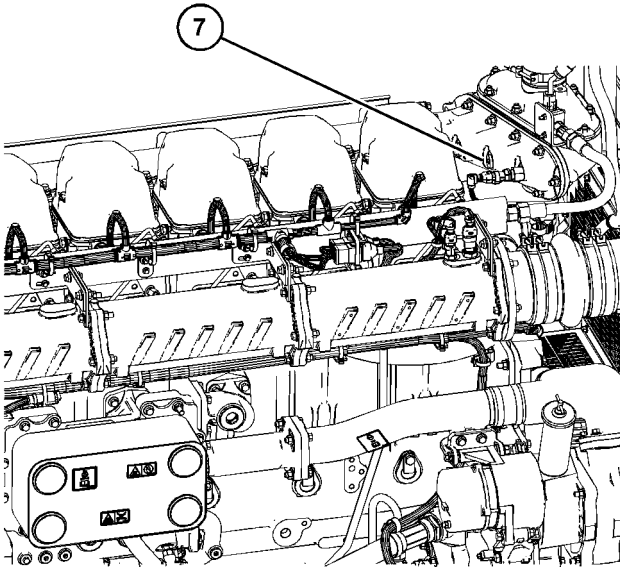

Illustration 85

g07792418

Typical example of a later engine

- Loosen the plug (7) on the water temperature regulator to allow air in the cooling system to vent to avoid air locks during filling.

**NOTICE**

Do not fill the cooling system faster than 5 L (1.3 US gal) per minute to avoid air locks.

Cooling system air locks may result in engine damage.

- Fill the cooling system with coolant. Refer to the Operation and Maintenance Manual, "Fluid Recommendations" topic (Maintenance Section) for more information on cooling system specifications.
- When coolant starts leaking from the cock (6), close the cock and continue to fill the cooling system.
- When coolant starts leaking from the plug (7), securely tighten the plug and continue to fill until the cooling system is full.

**Note:** Ensure that the filler cap is installed before operating the engine.

- Install power to the engine. Start the engine. Operate the engine to purge the air from the cavities of the engine block. Use the normal shutdown procedure to stop the engine.
- Isolate the electrical supply to the engine. Remove the filler cap. Check that the coolant level is within 25 mm (1.0 inch) of the bottom of the filler pipe.

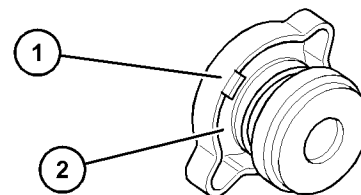

Illustration 86

g06258129

- Clean the cooling system filler cap (1) and inspect the seal (2). If the seal is damaged, discard the old filler cap and install a new filler cap. If the seal is not damaged, use a suitable pressurizing pump to pressure test the filler cap. The correct pressure is stamped on the face of the filler cap. If the filler cap does not retain the correct pressure, replace the filler cap.

Install the cooling system filler cap.

10. Install power to the engine. Start the engine.  
Operate the engine. Inspect the cooling system for leaks. Ensure that the cooling system operates at the correct temperature.

## Fill using a pump

1. Close the drain cock or install the drain plug (4) in the cylinder block.
2. To the radiator drain point, install a suitable adaptor / pipe / tap to connect a pump "(1/4 BSP)"

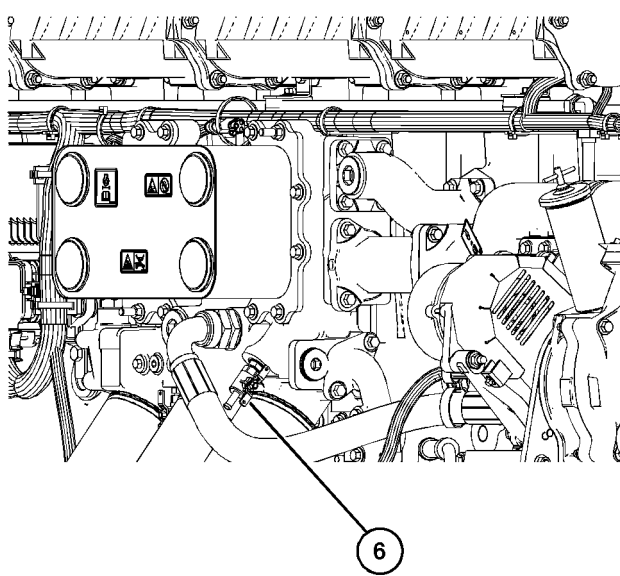

Illustration 87

g07792690

Typical example of a later engine

3. Open the drain cock (6) on the engine oil cooler to allow air in the cooling system to vent to avoid air locks during filling.

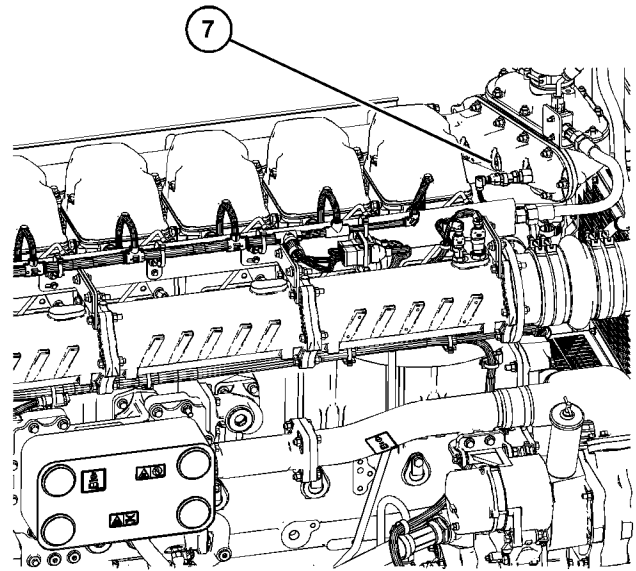

Illustration 88

g07792418

Typical example of a later engine

4. Loosen the plug (7) on the water temperature regulator to allow air in the cooling system to vent to avoid air locks during filling.

### NOTICE

Do not fill the cooling system faster than 5 L (1.3 US gal) per minute to avoid air locks.

Cooling system air locks may result in engine damage.

5. Using a pump, fill the cooling system with coolant. Refer to the Operation and Maintenance Manual, "Fluid Recommendations" topic (Maintenance Section) for more information on cooling system specifications.
6. When coolant starts leaking from the cock (6), close the cock and continue to fill the cooling system.
7. When coolant starts leaking from the plug (7) securely tighten the plug and continue to fill until the cooling system is full.

**Note:** Ensure that the filler cap is installed before operating the engine.

8. Install power to the engine. Start the engine. Operate the engine to purge the air from the cavities of the engine block. Use the normal shutdown procedure to stop the engine.
9. Isolate the electrical supply to the engine. Remove the filler cap. Check that the coolant level is within 25 mm (1.0 inch) of the bottom of the filler pipe.



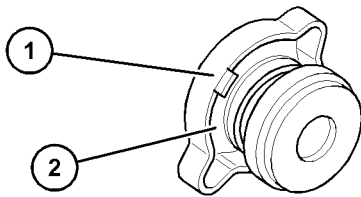

Illustration 89

g06258129

- 10.** Clean the cooling system filler cap (1) and inspect the seal (2). If the seal is damaged, discard the old filler cap and install a new filler cap. If the seal is not damaged, use a suitable pressurizing pump to pressure test the filler cap. The correct pressure is stamped on the face of the filler cap. If the filler cap does not retain the correct pressure, replace the filler cap.

Install the cooling system filler cap.

- 11.** Install power to the engine. Start the engine. Operate the engine. Inspect the cooling system for leaks. Ensure that the cooling system operates at the correct temperature.

i02415245

## Cooling System Coolant Level - Check

### WARNING

**Pressurized System: Hot coolant can cause serious burns. To open the cooling system filler cap, stop the engine and wait until the cooling system components are cool. Loosen the cooling system pressure cap slowly in order to relieve the pressure.**

Check the coolant level when the engine is stopped and cool.

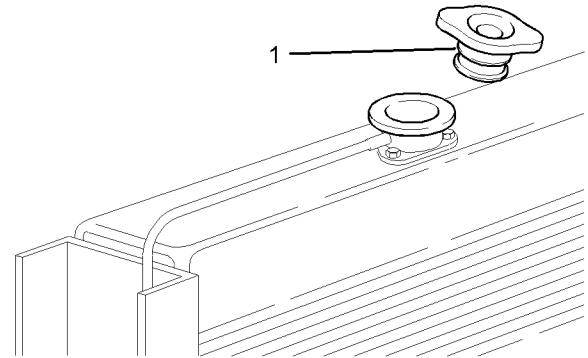

Illustration 90

g01211179

1. Remove the cooling system filler cap (1) slowly in order to relieve pressure.
2. Maintain the coolant level within 25 mm (1.0 inch) of the bottom of the filler pipe.

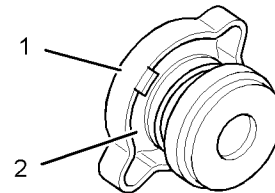

Illustration 91

g01239656

3. Clean the cooling system filler cap (1) and inspect the seal (2). If the seal is damaged, discard the old filler cap and install a new filler cap. If the seal is not damaged, use a suitable pressurizing pump in order to pressure test the filler cap. The correct pressure is stamped on the face of the filler cap. If the filler cap does not retain the correct pressure, replace the filler cap.

Install the cooling system filler cap.

4. Inspect the cooling system for leaks.

i10199808

## Crankshaft Vibration Damper - Inspect

Depending on the engine variant the engine can be equipped with one or two crankshaft vibration dampers. The crankshaft vibration damper limits the torsional vibration of the crankshaft. Damage to the crankshaft vibration damper can increase torsional vibrations. A damaged vibration damper can result in damage to the crankshaft and to other engine components.

The viscous damper has a weight that is located inside a fluid filled case. Inspect the damper for evidence of fluid leaks. If a fluid leak is found, determine the type of fluid.

Also inspect the dampers for signs of damage, or heat discoloration.

Inspect and replace the damper for any of the following reasons:

- The damper is dented, cracked, or leaking
- The paint on the damper is discolored from heat
- Analysis of the oil shows wear metals and particles
- The temperature of the damper fluid is 100 degrees Celsius and above

For more information on inspection the vibration dampers, refer to Systems Operation Testing and Adjusting, Vibration Damper.

i02151646

## Driven Equipment - Check

Refer to the OEM specifications for more information on the following maintenance recommendations for the driven equipment:

- Inspection
- Adjustment
- Lubrication
- Other maintenance recommendations

Perform any maintenance for the driven equipment which is recommended by the OEM.

i06683210

## Engine - Clean

### **WARNING**

**Personal injury or death can result from high voltage.**

**Moisture can create paths of electrical conductivity.**

**Make sure that the electrical system is OFF. Lock out the starting controls and tag the controls "DO NOT OPERATE" .**

---



---

### NOTICE

Accumulated grease and oil on an engine is a fire hazard. Keep the engine clean. Remove debris and fluid spills whenever a significant quantity accumulates on the engine.

---



---

### NOTICE

Water or condensation can cause damage to generator components. Protect all electrical components from exposure to water.

---



---

### NOTICE

Failure to protect some engine components from washing may make your engine warranty invalid. Allow the engine to cool for 1 hour before washing the engine.

---

Periodic cleaning of the engine is recommended. A clean engine provides the following benefits:

- Easy detection of fluid leaks
- Maximum heat transfer characteristics
- Ease of maintenance

**Note:** Caution must be used to prevent electrical components from being damaged by excessive water when the engine is cleaned. Pressure washers and steam cleaners should not be directed at any electrical connectors or the junction of cables into the rear of the connectors. Avoid electrical components such as the alternator, the starting motors, and the ECU.

Ensure that care is taken that the safety labels, emission label, and any information labels are not removed during engine cleaning.

i07214345

## Engine Air Cleaner Element - Replace

---

### NOTICE

Never run the engine without an air cleaner element installed. Never run the engine with a damaged air cleaner element. Do not use air cleaner elements with damaged pleats, gaskets or seals. Dirt entering the engine causes premature wear and damage to engine components. Air cleaner elements help to prevent airborne debris from entering the air inlet.

---



---

### NOTICE

Never service the air cleaner element with the engine running since this will allow dirt to enter the engine.

---

i02415251

Renew the air filter elements if the service indicators are triggered. Refer to Operation and Maintenance Manual, "Engine Air cleaner Service Indicator - Inspect" for more information.

Some engines are equipped with air intake precleaners. Clean the precleaners before maintenance is performed on the air filters. When performing maintenance, ensure that dirt does not enter the housing of the air cleaner.

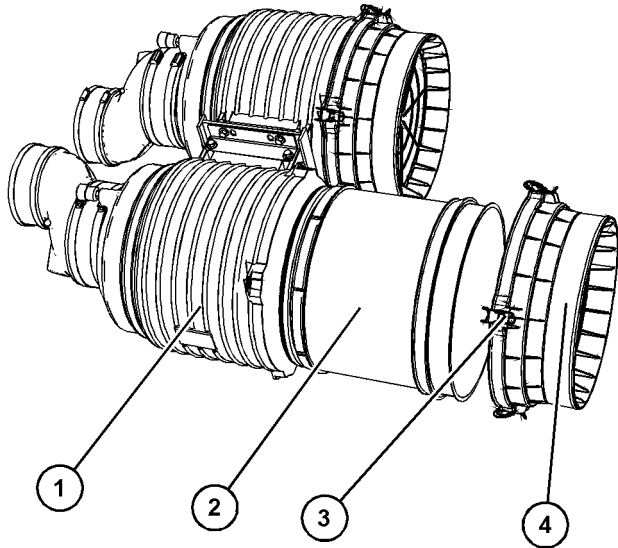

Illustration 92

g06254673

1. Isolate the electrical supply to the engine.
2. Ensure that the air cleaner body is clean and free from dirt. Remove clips (3) and remove end cover (4) from filter body (1).
3. Remove old element (2) and discard. Note the orientation of the filter element for installation.
4. Check the new filter element for damage before installing new filter element into filter body (1).
5. Ensure that end cover (4) is clean and free from dirt before installing end cover (4). Then, secure clips (3). The engine is equipped with 2 filter elements, when performing maintenance both filter elements must be changed.
6. Connect the electrical power to the engine.

## Engine Air Cleaner Service Indicator - Inspect

### Service Indicator Check

Check the service indicators. Replace the air filter elements if one of service indicators has been triggered.

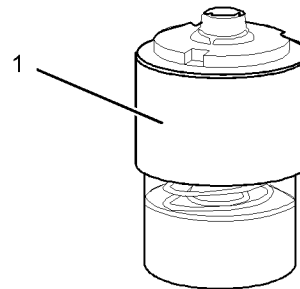

Illustration 93

g01242320

When the air filter element is in a serviceable condition, the center section of the service indicator (1) is clear.

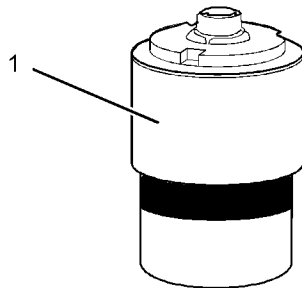

Illustration 94

g01242332

When the air filter element requires replacement, the center section of the service indicator (1) is red.

## Service Indicator Reset

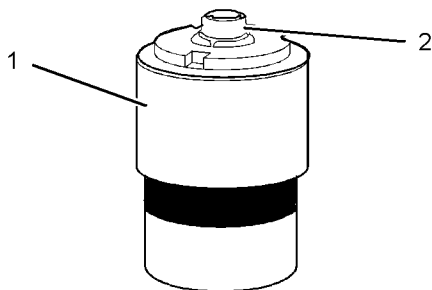

Illustration 95

g01242328

Once the service indicator has been triggered and when the air filter element has been replaced, the service indicator must be reset. In order to reset the service indicator (1), press the button (2).

If the service indicator does not reset easily, the service indicator should be replaced.

**Note:** The service indicator may need to be replaced frequently in environments that are severely dusty.

i08399384

## Engine Crankcase Breather - Clean

The breather has no filter element that needs to be replaced. The breather will only require cleaning.

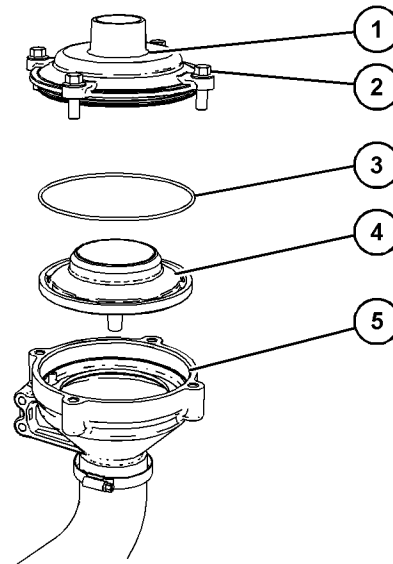

Illustration 96

g06009120

Typical example

1. Isolate the electrical supply to the engine.
2. Ensure that the outer casing of the breather is clean and free from dirt. A suitable degreaser can be used to clean the outer casing. Remove the bolts (2) and remove cover (1) from breather body (5).
3. Remove O ring seal (3) and discard.
4. Remove breather baffle (4) and clean the breather baffle, cover, and breather body. A suitable degreaser can be used to clean these items.
5. Install cleaned breather baffle (4) into clean breather body (5). Install new O ring seal (3) onto cover (1) and install cover to breather body (5).
6. Install bolts (1) and tighten bolts to a torque of 50 N·m (36 lb ft). Install power to the engine.

i10198897

## Engine Crankcase Breather - Clean/Replace

### Closed Breather System

Ensure that the power supply is disconnected from the engine.

Some applications may be equipped with a cold climate kit for the engine crankcase breather. If equipped, remove the cold climate kit before cleaning/ replacing the filter.

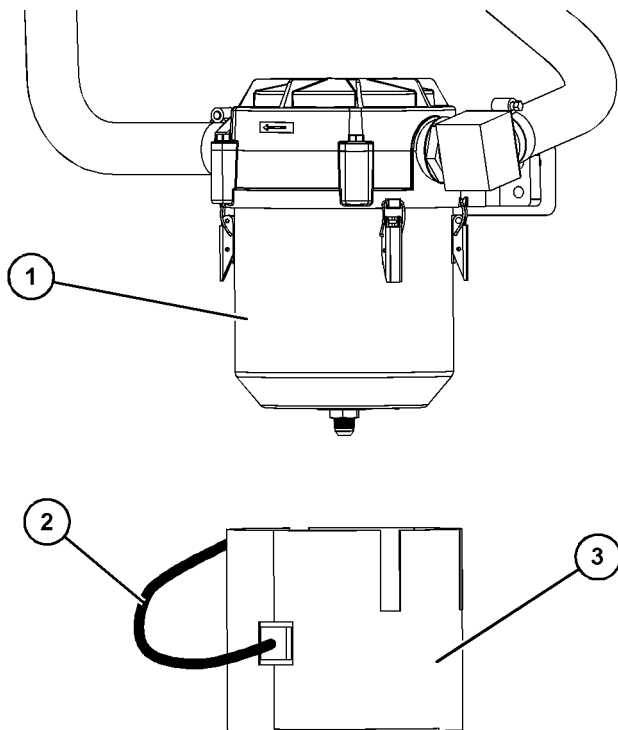

Illustration 97

g07790143

1. Disconnect the cable (2) from the wiring harness.
2. Slide the cold climate kit (3) downwards from the bowl (1).

After the cold climate kit has been removed, continue to clean/replace the filter.

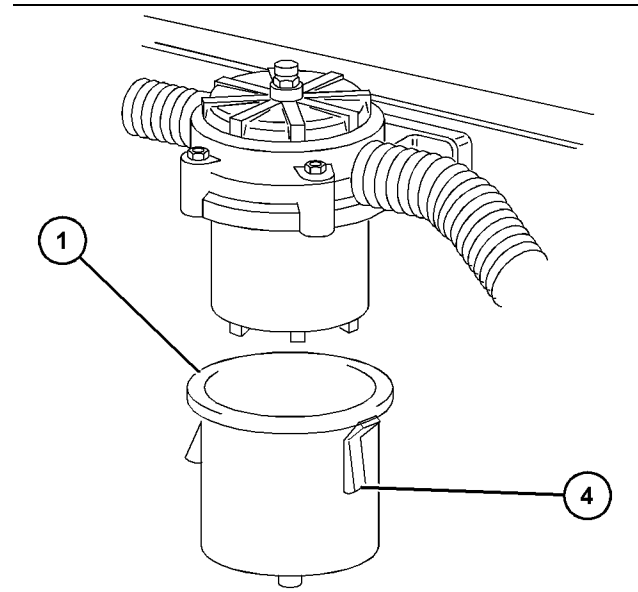

Illustration 98

g07790162

Typical example

1. Release the four clips (4). Remove the bowl (1) and remove the old filter element. Discard the old filter element in accordance with local regulations.

**Note:** The filter element is removed by pulling down on the filter element.

2. Ensure that the seal (5) is installed onto the new filter element (6).

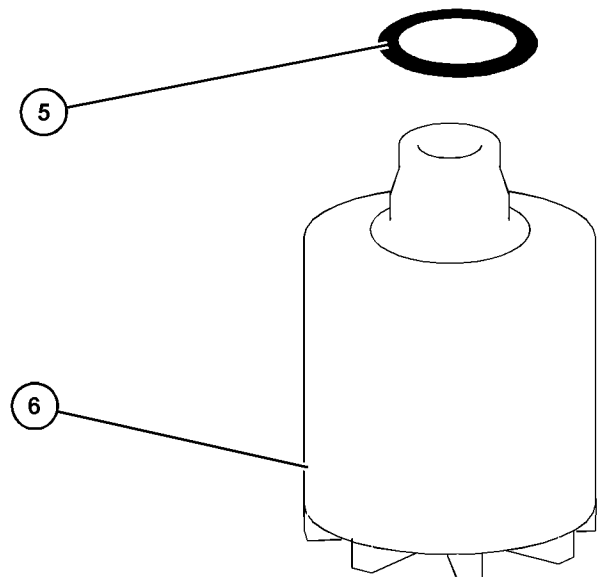

Illustration 99

g07790187

Typical example

3. Install the new filter element. Align the clips (4).  
 Install the bowl (1).

Connect the power supply to the engine. Operate the engine and check for leaks.

i10198507

## Engine Mounts - Inspect

Misalignment of the engine and the driven equipment will cause extensive damage. Excessive misalignment can lead to vibration. Excessive vibration can lead to misalignment. Excessive vibration of the engine and the driven equipment can be caused by the following conditions:

- Improper mounting
- Loose bolts
- Deterioration of the isolators

Ensure that the mounting bolts are tightened to the correct torque.

Ensure that the isolators are free of oil and contamination. Inspect the isolators for deterioration. Ensure that the bolts for the isolators are tightened to the correct torque.

Replace any isolator that shows deterioration. For more information, see the literature that is provided by the OEM of the isolators.

i09771490

## Engine Oil Level - Check

### **WARNING**

**Hot oil and hot components can cause personal injury. Do not allow hot oil or hot components to contact the skin.**

---

### NOTICE

Perform this maintenance with the engine stopped.

---

**Note:** After the engine has been switched OFF, wait for 10 minutes to allow the engine oil to drain to the oil pan. Then check the oil level.

---

### NOTICE

Operating your engine when the oil level is above the "Max" mark could cause your crankshaft to dip into the oil. The air bubbles created from the crankshaft dipping into the oil reduces the oils lubricating characteristics and could result in the loss of power.

---

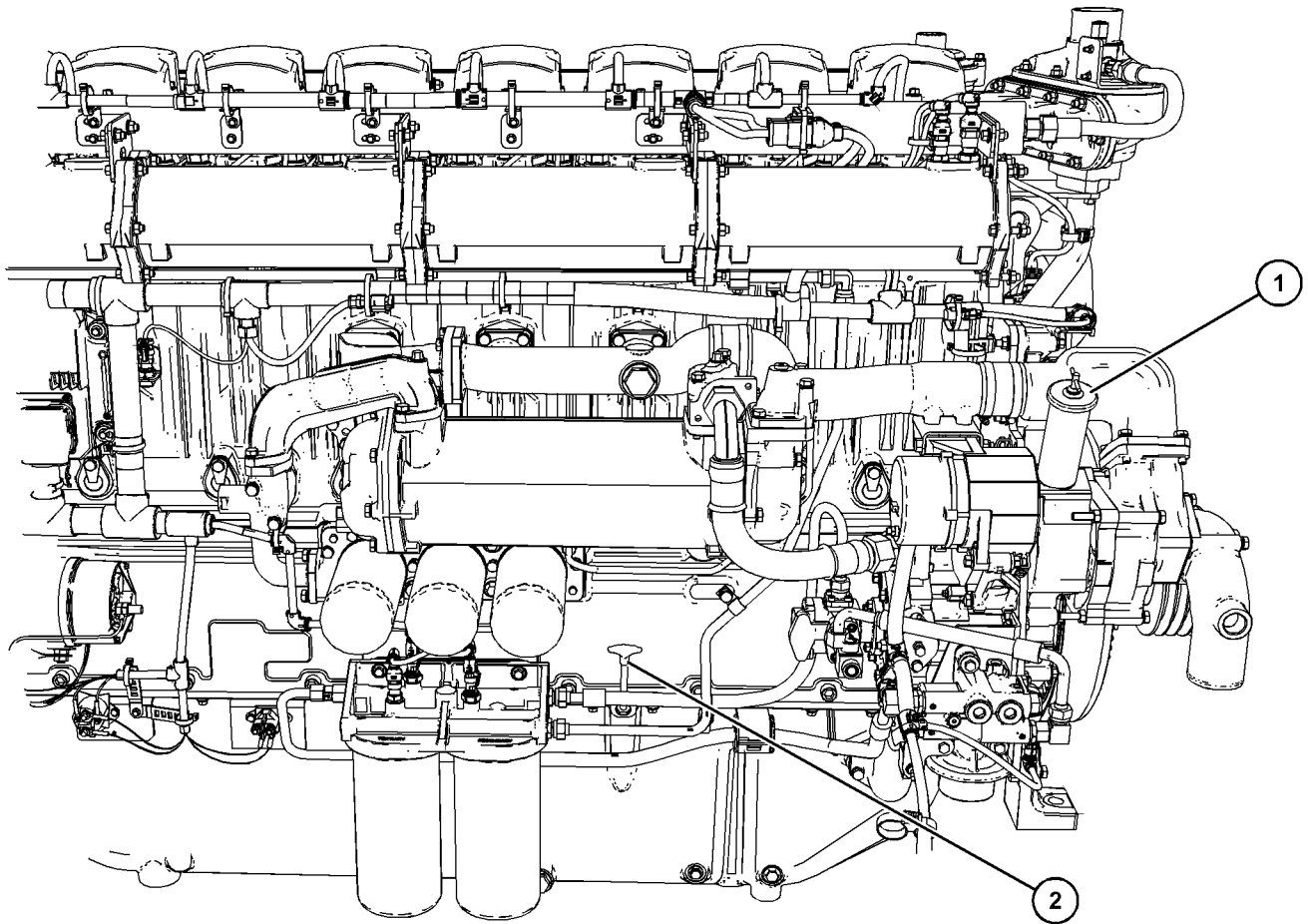

Illustration 100

Typical example of an earlier engine

g06597046

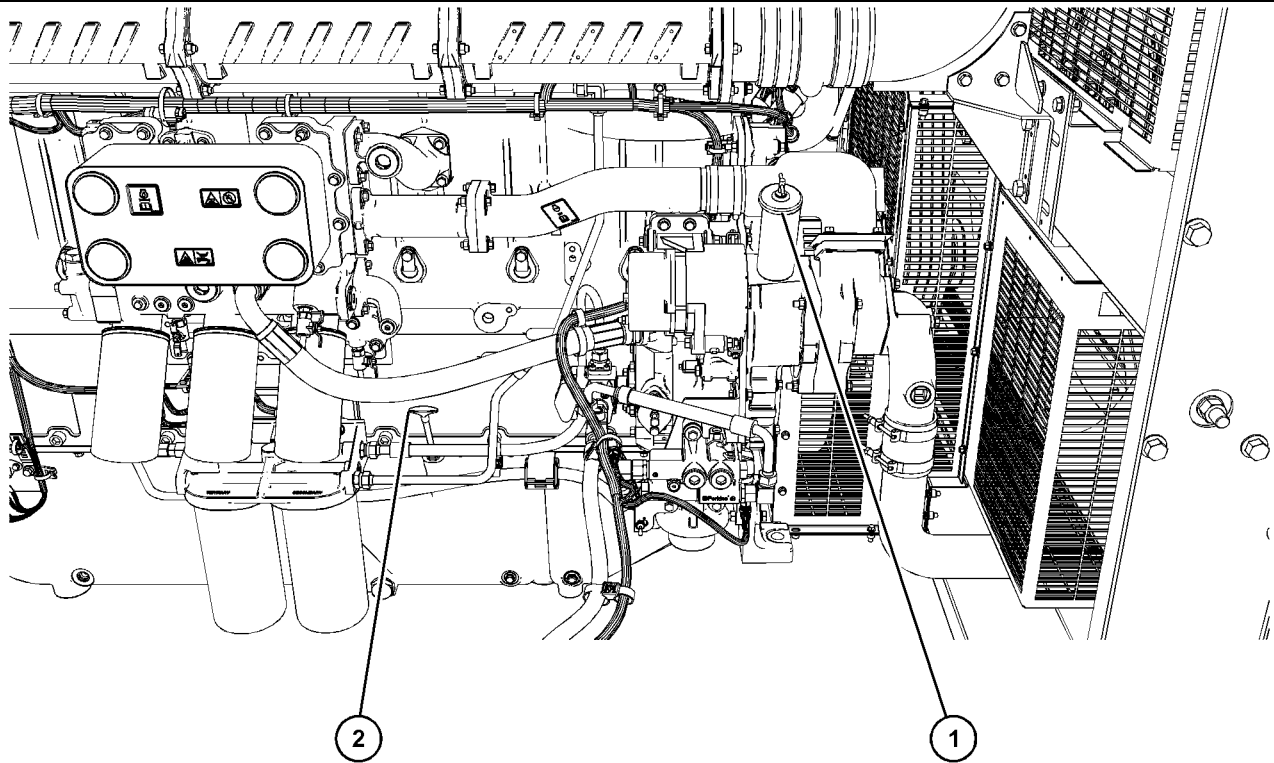

Illustration 101

g07587560

Typical example of a later engine

i08397579

## Engine Oil Pump - Inspect

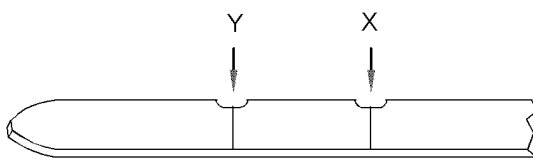

Illustration 102

g01165836

(Y) "Min" mark. (X) "Max" mark.

1. Maintain the oil level between the "Min" mark (Y) and the "Max" mark (X) on the engine oil level gauge (2), refer to Illustration 102 . Do not fill the oil pan above the "Max" mark (X).
2. If necessary, remove the oil filler cap (1) and add oil. Clean the oil filler cap. Install the oil filler cap.

A failed engine oil pump may result in a seizure of the crankshaft. A failed engine oil pump may result in contaminating the engine lubricating system.

Visually inspect the oil pump for leaks or damage. If abnormal noise is observed in the oil pump area with the engine running, there may be a problem with the engine oil pump.

Check oil pressure using an Electronic Service Tool (EST) to determine if the oil pump is failing. For more information consult your Perkins distributor.

Remove the engine oil pump and disassemble the engine oil pump. Replace any components that are worn or damaged. Alternatively, replace the engine oil pump. For more information consult your Perkins distributor.



i08304132

## Engine Oil Sample - Obtain

The condition of the engine lubricating oil should be checked at regular intervals as part of the preventive maintenance program.

### Initiating an Oil analysis Program

#### Initial Oil Sample

An initial Oil analysis will show higher levels of iron and copper than acceptable parameters. As the engine continues to operate, the levels will drop within the specified parameters.

#### Subsequent Oil Samples

A trend can be established by analyzing the results of the oil sampling. Each individual operator can develop a service program for the engine.

**Note:** Perkins Engines Stafford must agree to the maintenance schedule.

### Obtain the Sample and the Analysis

#### WARNING

**Hot oil and hot components can cause personal injury. Do not allow hot oil or hot components to contact the skin.**

The oil sample must be taken from the mean level in the engine oil pan. Do not take an oil sample from the drain plug.

To help obtain the most accurate analysis, record the following information before an oil sample is taken:

- The date of the sample
- Engine model
- Engine number
- Service hours on the engine
- The number of hours that have accumulated since the last oil change
- The amount of oil that has been added since the last oil change

Ensure that the container for the sample is clean and dry. Also ensure that the container for the sample is clearly labeled.

To ensure that the sample is representative of the oil in the crankcase, obtain a warm, well-mixed oil sample.

To avoid contamination of the oil samples, the tools and the supplies that are used for obtaining oil samples must be clean.

The sample can be checked for the following: the quality of the oil, the existence of any coolant in the oil, the existence of any ferrous metal particles in the oil and the existence of any nonferrous metal particles in the oil.

i10198641

## Engine Oil and Filter - Change

#### WARNING

**Hot oil and hot components can cause personal injury. Do not allow hot oil or hot components to contact the skin.**

#### NOTICE

Care must be taken to ensure that fluids are contained during performance of inspection, maintenance, testing, adjusting and repair of the product. Be prepared to collect the fluid with suitable containers before opening any compartment or disassembling any component containing fluids.

Dispose of all fluids according to local regulations and mandates.

#### NOTICE

Keep all parts clean from contaminants.

Contaminants may cause rapid wear and shortened component life.

Do not drain the engine lubricating oil when the engine is cold. As the engine lubricating oil cools, suspended waste particles settle on the bottom of the oil pan. The waste particles are not removed with draining cold oil. Drain the oil pan with the engine stopped. Drain the oil pan with the oil warm. This draining method allows the waste particles that are suspended in the oil to be drained properly.

Failure to follow this recommended procedure will cause the waste particles to be recirculated through the engine lubrication system with the new oil.

### Oil and Filter Change Intervals

There are several other factors that can alter the engine oil and filter change interval.

Maintenance Section  
 Engine Oil and Filter - Change

- If the engine is using engine oil analysis to determine oil and filter change period.
- The engine is working in a severe service environment/Load Factor
- Infrequent operation of the engine

Refer to this Operation and Maintenance Manual, "Severe Service Application" for more information on reducing the engine oil and filter change period.

If the engine is operated in severe service conditions, Perkins recommends the use of engine oil sampling. Refer to this Operation and Maintenance Manual, Engine Oil sample - Obtain for more information.

The engine oil analysis will provide more information on wear metals, oil viscosity, and other properties of the engine oil. Refer to Specifications, Engine Oil Filter (Extended Oil Service) for more information.

### Drain the Engine Lubricating Oil

Operate the engine so that the lubricating oil is warm, then stop the engine. Isolate the electrical power to the stater.

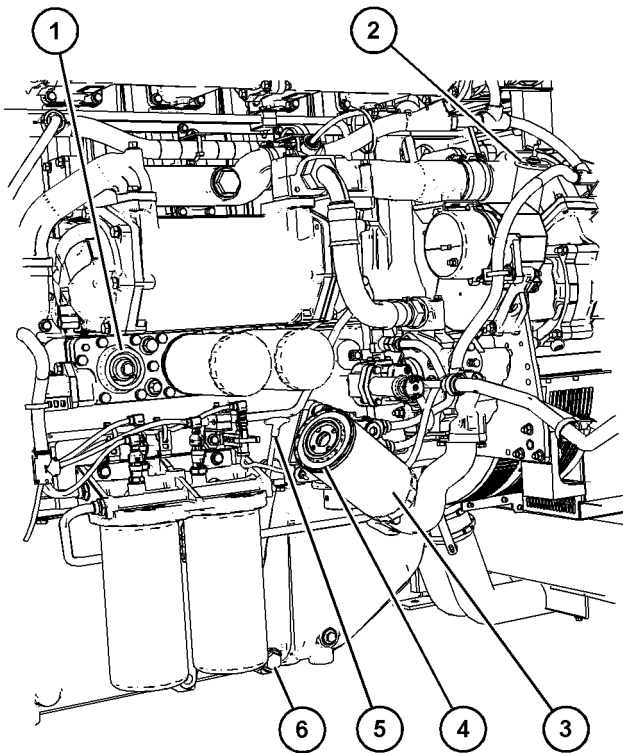

Illustration 103 g06327798  
 Typical example of an earlier engine

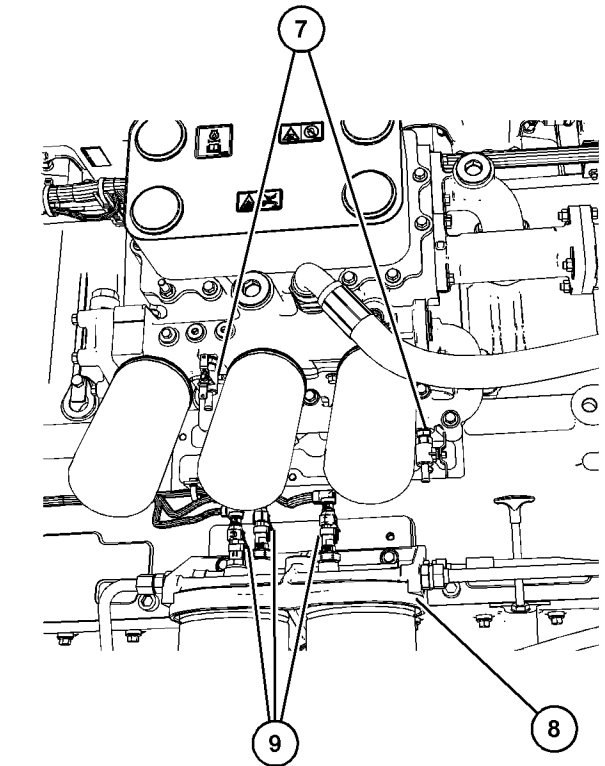

Illustration 104 g07610552  
 Typical example of a later engine

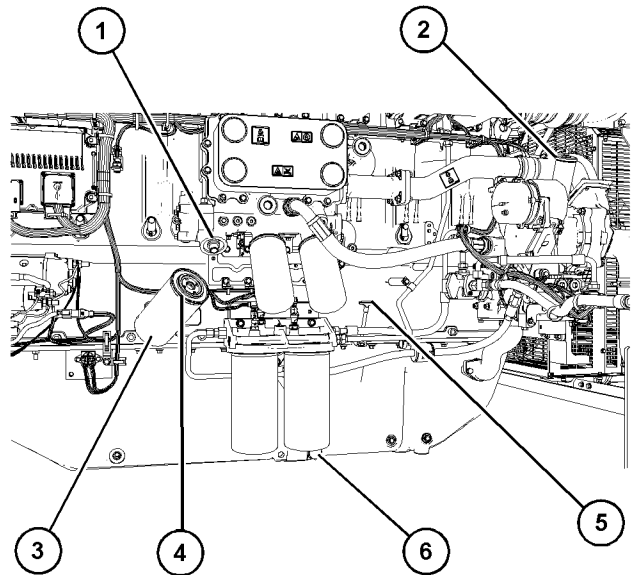

Illustration 105 g07588204  
 Typical example of a later engine

1. Place a suitable container below the engine oil pan. Remove the drain plug (6). Allow the engine oil to drain.

**Note:** Ensure that the vessel that will be used is large enough to collect the waste oil.

- Remove the sealing washer from the drain plug (6). Discard the sealing washer.
- On later engines install one end of suitable tubing to the drain valves (7) on the engine oil cooler. Place the other end of the tubing in the drain container below the engine oil pan and open the drain valves.

**Note:** When removing the drain tubing and removing the oil filters, ensure the electrical connections and sensors (9) on the fuel filter base (8) are adequately protected from oil drips and spillage.

- Close the drain valves (7) and remove the drain tubing.
- Install a new sealing washer to the drain plug (6). Install the drain plug to the engine oil pan. Tighten the plug to a torque of 68 N·m (50 lb ft).

## Replace the Oil Filter

Table 11

Required Tools			
Tool	Part Number	Part Name	Qty
A	-	Strap Wrench	1

**Note:** Ensure that all 3 oil filters are changed as a set.

- Use Tooling (A) to remove the oil filters (3)
- Ensure that the sealing face of the filter base (1) is clean and free from dirt.
- Lubricate the O rings (4) with clean engine oil. Install the new oil filter (3).
- Spin on the oil filter until the O ring (4) contacts the sealing surface (1). Then rotate the oil filter  $\frac{3}{4}$  of a full turn or tighten to a torque of 34 N·m (25 lb ft). After all the oil filters have been replaced, fill the oil pan.

## Fill the Oil Pan

Refer to Operation and Maintenance Manual, "Fluid Recommendations" for information on suitable oils.

- Remove the oil filler cap (2).
- Fill the oil pan with the correct amount of new engine lubricating oil and install the filler cap. Refer to Operation and Maintenance Manual, "Refill Capacities" for more information. Restore electrical power to the starter.

### NOTICE

If equipped with an auxiliary oil filter system or a remote filter system, follow the OEM or the filter manufacturer's recommendations. Under-filling or over filling the crankcase with oil can cause engine damage.

**Note:** Before starting the engine, the engine oil system must be primed. Refer to Operation and Maintenance Manual, "Before Starting Engine" for the procedure to prime the engine oil system.

- Start the engine and run the engine for 2 minutes. Perform this procedure to ensure that the lubrication system has oil and that the oil filters are filled. Inspect the oil filters for oil leaks.
- Stop the engine and allow the oil to drain back to the oil pan for a minimum of 10 minutes.

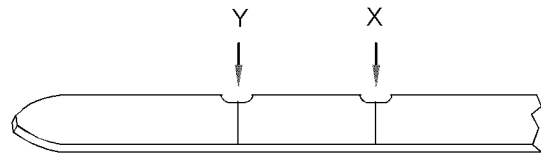

Illustration 106

g01165836

(Y) "Min" mark. (X) "Max" mark.

- Remove the engine oil level gauge (5) to check the oil level. Maintain the oil level between the "MIN" and "MAX" marks on the engine oil level gauge.

i10199815

## Engine Protective Devices - Check (Including Sensor Pack)

Alarms and shutoffs must function properly. Alarms provide timely warning to the operator. Shutoffs help to prevent damage to the engine. It is impossible to determine if the engine protective devices are in good working order during normal operation. Malfunctions must be simulated to test the engine protective devices.

A calibration check of the engine protective devices will ensure that the alarms and shutoffs activate at the setpoints. Ensure that the engine protective devices are functioning properly.

#### NOTICE

During testing, abnormal operating conditions must be simulated.

The tests must be performed correctly in order to prevent possible damage to the engine.

To prevent damage to the engine, only authorized service personnel or your Perkins dealer should perform the tests.

## Visual Inspection

Visually check the condition of all gauges, sensors, and wiring. Look for wiring and components that are loose, broken, or damaged. Damaged wiring or components should be repaired or replaced immediately.

i09415387

## Engine Valve Lash - Inspect/Adjust (Valves and Valve Bridges)

### WARNING

Ensure that the engine cannot be started while this maintenance is being performed. To help prevent possible injury, do not use the starting motor to turn the flywheel.

Hot engine components can cause burns. Allow additional time for the engine to cool before measuring/adjusting valve lash clearance.

#### NOTICE

Only qualified service personnel should perform this maintenance. Refer to the Service Manual or your authorized Perkins dealer or your Perkins distributor for the complete valve lash adjustment procedure.

Operation of Perkins engines with incorrect valve lash can reduce engine efficiency, and also reduce engine component life.

**Note: The valve bridges must be equalized before the valve lash is adjusted.**

Record the valve clearance. Refer to Systems Operation, Testing and Adjusting, "Valve Lash - Adjust" for the correct procedure.

**Note:** The valve depth is to be measured at every service. The valve recession can then be calculated. A valve recession tool has been designed to give service personnel a good indication of the cylinder head valve recession or cylinder head valve seat wear without the need to remove the cylinder heads. Refer to Operation and Maintenance Manual, Overhaul (Top End) or contact your Perkins distributor for more information.

i09812568

## Fan Drive Pulley - Check (5008A-E30TA, 5008C-E30TA, and 5008AC-E30TA Engines Only)

1. Isolate the electrical supply to the engine.

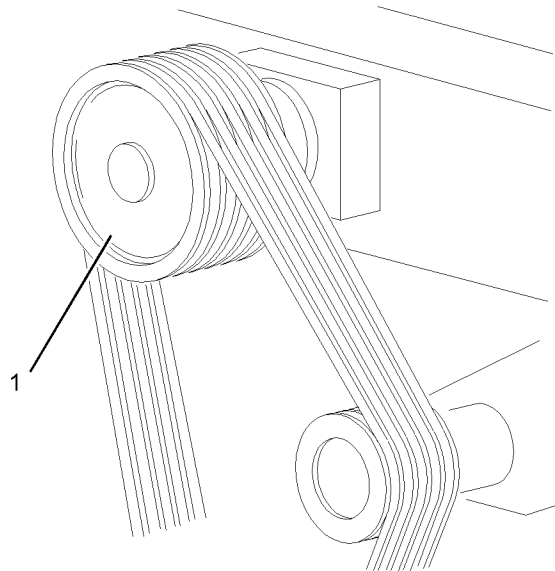

Illustration 107

g01238304

Typical example

2. Remove the guards (not shown) to gain access to the fan drive pulley (1).

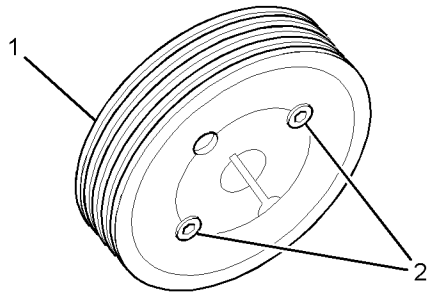

Illustration 108

g01238305

3. Tighten the grub screws (2) to a torque of 90 N·m (66 lb ft).
4. Install the guards (not shown).
5. Restore the electrical supply to the engine.

i08456754

## Fuel Injector - Inspect/Adjust

### NOTICE

Only qualified service personnel should perform this maintenance. Refer to the Service Manual or your authorized Perkins distributor for the complete procedure to inspect or adjust the fuel injectors.

Operation of Perkins engines with fuel injectors that have not been inspected or adjusted can reduce engine efficiency, and also reduce engine component life.

Refer to Systems Operation, Testing and Adjusting, "Electronic Unit Injector - Test" and "Electronic Unit Injector - Adjust" for the correct procedures to inspect and adjust the fuel injectors.

i07398052

## Fuel Injector - Replace

### WARNING

Fuel leaked or spilled onto hot surfaces or electrical components can cause a fire.

### NOTICE

Do not allow dirt to enter the fuel system. Thoroughly clean the area around a fuel system component that will be disconnected. Fit a suitable cover over any disconnected fuel system components.

### NOTICE

If a fuel injector is suspected of operating outside of normal parameters it should be removed by a qualified technician. The suspect fuel injector should be taken to an authorised agent for inspection.

Refer to the appropriate Disassembly and Assembly manual for the removal and installation procedure.

i08238504

## Fuel System - Prime

If air enters the fuel system, the air must be purged from the fuel system before the engine can be started. Air can enter the fuel system when the following events occur:

- The fuel day tank is empty or partially drained
- The low-pressure fuel lines are disconnected
- A leak exists in the low-pressure fuel system
- The fuel filter has been replaced

Use the following procedures to remove air from the fuel system.

### NOTICE

Do not crank the engine continuously for more than 30 seconds. Allow the starting motor to cool for two minutes before cranking the engine again.

i08246229

## Fuel System Primary Filter - Replace

### **⚠ WARNING**

Fuel leaked or spilled onto hot surfaces or electrical components can cause a fire. To help prevent possible injury, turn the start switch off when changing fuel filters or water separator elements. Clean up fuel spills immediately.

### **NOTICE**

Ensure that the engine is stopped and the battery is isolated, before any servicing or repair is performed.

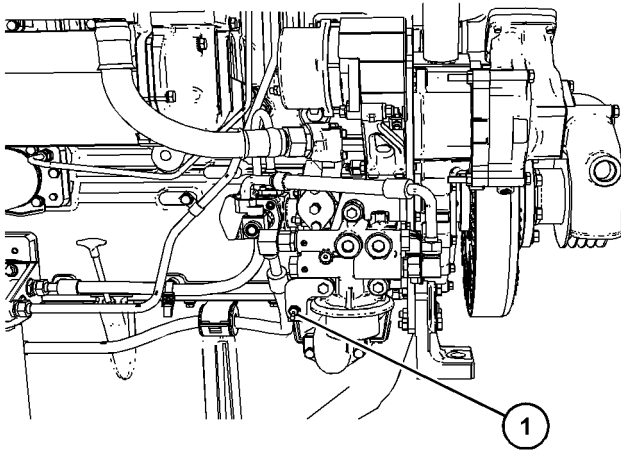

Illustration 109

g06597104

(1) Fuel priming switch

1. The fuel system can be primed from the key switch or from a remote mounted switch (1).
2. Ensure that any fuel isolation switches to the engine are in the open position to allow the correct fuel flow.
3. Turn the fuel priming switch (1) to the ON position. Hold the fuel priming switch in the ON position for 2 minutes.
4. Attempt to start the engine.
5. If the engine cannot be started, or if the engine runs rough, or if the engine misfires, or if the engine smoke, stop the engine. Repeat Step 3 through Step 5.

The fuel system can also be primed by using the key switch. Turn the key to the ON position for 2 minutes. After 2 minutes the fuel system should be primed. If necessary, by cycling the key switch the system will prime again for 2 minutes.

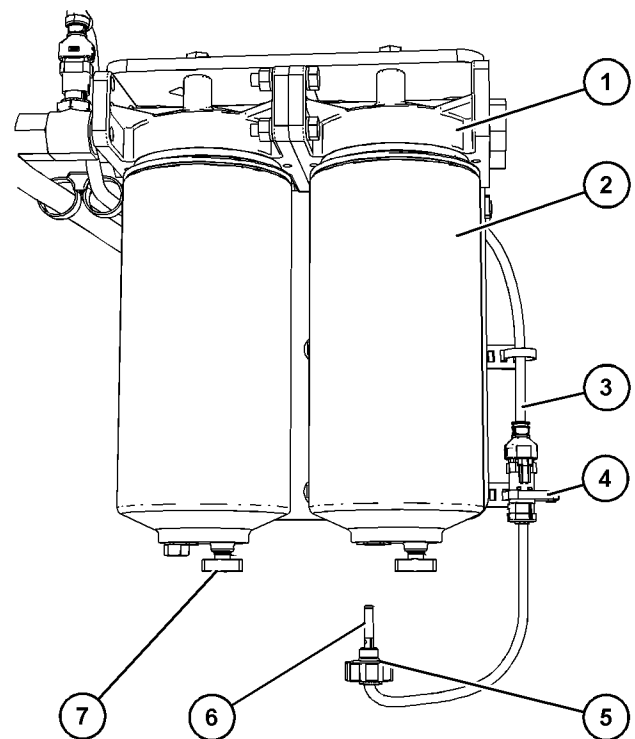

Illustration 110

g06597507

Typical example

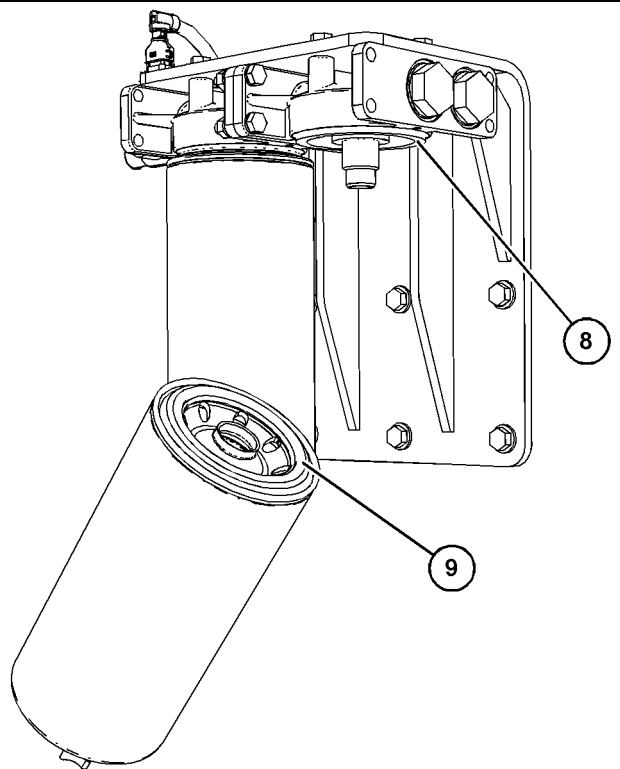

Illustration 111

g06597518

1. Isolate the fuel supply to the engine.
2. Place a suitable container under the fuel filter to catch any fuel that might spill. Clean up any spilled fuel immediately. The engine is equipped with two primary fuel filters all the primary filter must be replaced.
3. Clean the outside of the fuel filters. Open the drain valve (7) on both primary fuel filters and allow the fuel to drain.
4. Remove Water In Fuel (WIF) sensor (6).
5. If necessary, cut cable strap (4) and disconnect the WIF sensor from harness assembly (3).
6. Use a suitable strap wrench to remove the primary fuel filter (2) from fuel filter head (.). Discard the fuel filter.
7. Ensure that the sealing surface (8) is clean the free from dirt. Lubricate O ring seal (9) on the new primary fuel filters with clean fuel oil.
8. Install the new primary fuel filter to the fuel filter head using hand pressure only. When the O ring seal (9) contacts the sealing surface (8), rotate the primary fuel filter 3/4 of a turn.
9. Repeat Step 6 through Step 8 for the remaining fuel filter.

10. Install new O ring seal (5) to the WIF sensor.
11. Install the WIF sensor.
12. If necessary, connect the WIF sensor to harness assembly (3) and install new cable strap (4).
13. When the primary fuel filters have been replaced, the secondary fuel filters must be replaced. Refer to "Operation and Maintenance Manual" Secondary Fuel Filter- Replace for more information.

i08383275

## Fuel System Primary Filter/ Water Separator - Drain

### **⚠ WARNING**

Fuel leaked or spilled onto hot surfaces or electrical components can cause a fire. To help prevent possible injury, turn the start switch off when changing fuel filters or water separator elements. Clean up fuel spills immediately.

### NOTICE

Ensure that the engine is stopped before any servicing or repair is performed.

1. Place a suitable container under the fuel filters (1) to catch any fuel that might spill. Clean up any spilled fuel.

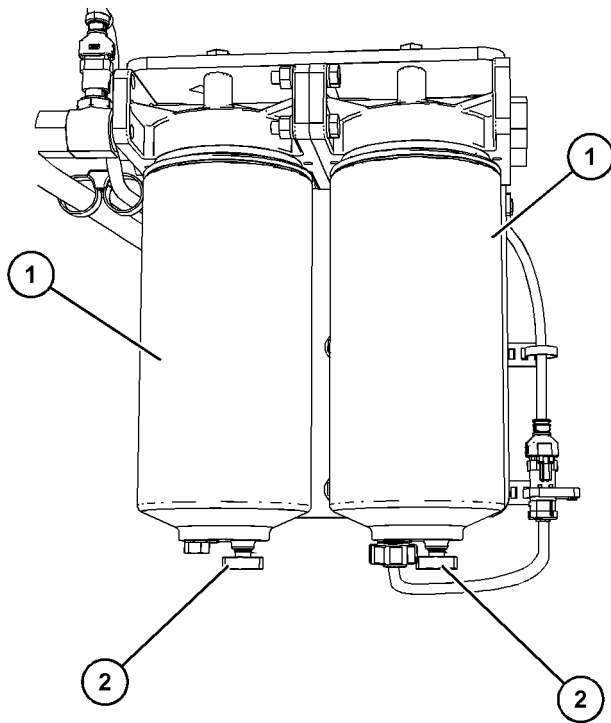

Illustration 112

g06650982

### Typical example

2. Install a suitable tube onto the drain (2). Open the drain (2). Allow the fluid to drain into the container.
3. When only fuel free of water is draining, tighten the drain (2) by hand pressure only. Remove the tube and dispose of the drained fluid in accordance with local regulations and mandates.

i08391556

## Fuel System Secondary Filter - Replace

### WARNING

Fuel leaked or spilled onto hot surfaces or electrical components can cause a fire. To help prevent possible injury, turn the start switch off when changing fuel filters or water separator elements. Clean up fuel spills immediately.

### NOTICE

Ensure that the engine is stopped and the battery is isolated, before any servicing or repair is performed.

A fuel temperature sensor and two fuel pressure sensors are mounted in the fuel filter base. The Engine Control Module (ECM) uses the sensors to monitor the temperature and pressure of the fuel that is entering the engine.

The electronic service tool (EST) can be used to monitor the fuel pressure. Contact Perkins distributor for more information.

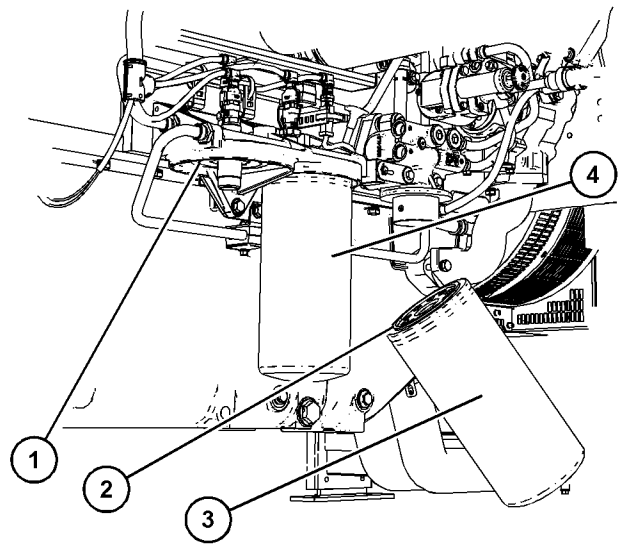

Illustration 113

g06309402

### Typical example

1. Ensure that the fuel supply valve is in the OFF position.
2. Clean the outside of the secondary and tertiary fuel filters.
3. Use a suitable strap wrench to remove the tertiary fuel filter (3) and discard the old tertiary fuel filter.
4. Lubricate the O ring seal (2) on the new tertiary fuel filter with clean engine oil. Ensure that the sealing surface (1) is clean and free from dirt.
5. Installed the new fuel filter by hand only. When the O ring seal (2) contacts the sealing surface (1), rotate the tertiary fuel filter 1 full turn.
6. Repeat Step 3 through Step 5 for the secondary filter (4).
7. Remove the container and dispose of the fuel in accordance with local regulations.
8. Restore the fuel supply to the engine.
9. Prime the fuel system. Refer to the Operation and Maintenance Manual, "Fuel System - Prime" for more information.



10. Start the engine and run the engine. Check the fuel system for leaks.

i02335436

## Fuel Tank Water and Sediment - Drain

### NOTICE

Care must be taken to ensure that fluids are contained during performance of inspection, maintenance, testing, adjusting and repair of the product. Be prepared to collect the fluid with suitable containers before opening any compartment or disassembling any component containing fluids.

Dispose of all fluids according to local regulations and mandates.

### Fuel Tank

Fuel quality is critical to the performance and to the service life of the engine. Water in the fuel can cause excessive wear to the fuel system.

Water can be introduced into the fuel tank when the fuel tank is being filled.

Condensation occurs during the heating and cooling of fuel. The condensation occurs as the fuel passes through the fuel system and the fuel returns to the fuel tank. This causes water to accumulate in fuel tanks. Draining the fuel tank regularly and obtaining fuel from reliable sources can help to eliminate water in the fuel.

### Drain the Water and the Sediment

Fuel tanks should contain some provision for draining water and draining sediment from the bottom of the fuel tanks.

Open the drain valve on the bottom of the fuel tank in order to drain the water and the sediment. Close the drain valve.

Check the fuel daily. Allow five minutes after the fuel tank has been filled before draining water and sediment from the fuel tank.

Fill the fuel tank after operating the engine in order to drive out moist air. This will help prevent condensation. Do not fill the tank to the top. The fuel expands as the fuel gets warm. The tank may overflow.

Some fuel tanks use supply pipes that allow water and sediment to settle below the end of the fuel supply pipe. Some fuel tanks use supply lines that take fuel directly from the bottom of the tank. If the engine is equipped with this system, regular maintenance of the fuel system filter is important.

### Fuel Storage Tanks

Drain the water and the sediment from the fuel storage tank at the following intervals:

- Weekly
- Service intervals
- Refill of the tank

This will help prevent water or sediment from being pumped from the storage tank into the engine fuel tank.

If a bulk storage tank has been refilled or moved recently, allow adequate time for the sediment to settle before filling the engine fuel tank. Internal baffles in the bulk storage tank will also help trap sediment. Filtering fuel that is pumped from the storage tank helps to ensure the quality of the fuel. When possible, water separators should be used.

i07426322

### Fuel Transfer Pump (Lift Pump) - Inspect

Visually inspect the lift pump for leaks. The lift pump is not a serviceable item. Replace a lift pump that is faulty. Replace a lift pump that leaks.

i10199197

### Hoses and Clamps - Inspect/Replace

#### WARNING

**Contact with high pressure fuel may cause fluid penetration and burn hazards. High pressure fuel spray may cause a fire hazard. Failure to follow these inspection, maintenance and service instructions may cause personal injury or death.**

If you inspect the engine in operation, always use the proper inspection procedure to avoid a fluid penetration hazard. Refer to Operation and Maintenance Manual, "General hazard Information".

Inspect all hoses for leaks that are caused by the following conditions:

- Cracking
- Softness
- Loose clamps

Replace hoses that are cracked or soft. Tighten any loose clamps.

Check for the following conditions:

- End fittings that are damaged or leaking
- Outer covering that is chafed or cut
- Exposed wire that is used for reinforcement
- Outer covering that is ballooning locally
- Flexible part of the hose that is kinked or crushed
- Armoring that is embedded in the outer covering

A constant torque hose clamp can be used in place of any standard hose clamp. Ensure that the constant torque hose clamp is the same size as the standard clamp.

Due to extreme temperature changes, the hose will harden. Hardening of the hoses will cause hose clamps to loosen. This action can result in leaks. A constant torque hose clamp will help to prevent loose hose clamps.

Each installation application can be different. The differences depend on the following factors:

- Type of hose
- Type of fitting material
- Anticipated expansion and contraction of the hose
- Anticipated expansion and contraction of the fittings

## Replace the Hoses and the Clamps

Refer to the OEM information for further information on removing and replacing fuel hoses (if equipped).

The coolant system and the hoses for the coolant system are not always supplied by Perkins. The following text describes a typical method of replacing coolant hoses. Refer to the OEM information for further information on the coolant system and the hoses for the coolant system.

### **WARNING**

**Pressurized System: Hot coolant can cause serious burns. To open the cooling system filler cap, stop the engine and wait until the cooling system components are cool. Loosen the cooling system pressure cap slowly in order to relieve the pressure.**

---

1. Stop the engine. Allow the engine to cool.
2. Loosen the cooling system filler cap slowly to relieve any pressure. Remove the cooling system filler cap.

**Note:** Drain the coolant into a suitable, clean container. The coolant can be reused.

3. Drain the coolant from the cooling system to a level that is below the hose that is being replaced.
4. Remove the hose clamps.
5. Disconnect the old hose.
6. Replace the old hose with a new hose.
7. Install the hose clamps with a torque wrench.

**Note:** For the correct coolant, see this Operation and Maintenance Manual, "Fluid Recommendations".

8. Refill the cooling system. Refer to the OEM information for further information on refilling the cooling system.
9. Clean the cooling system filler cap. Inspect the cooling system filler cap seals. Replace the cooling system filler cap if the seals are damaged. Install the cooling system filler cap.

10. Start the engine. Inspect the cooling system for leaks.

## Clamps and V-Band Locations For 6 Cylinder Engines

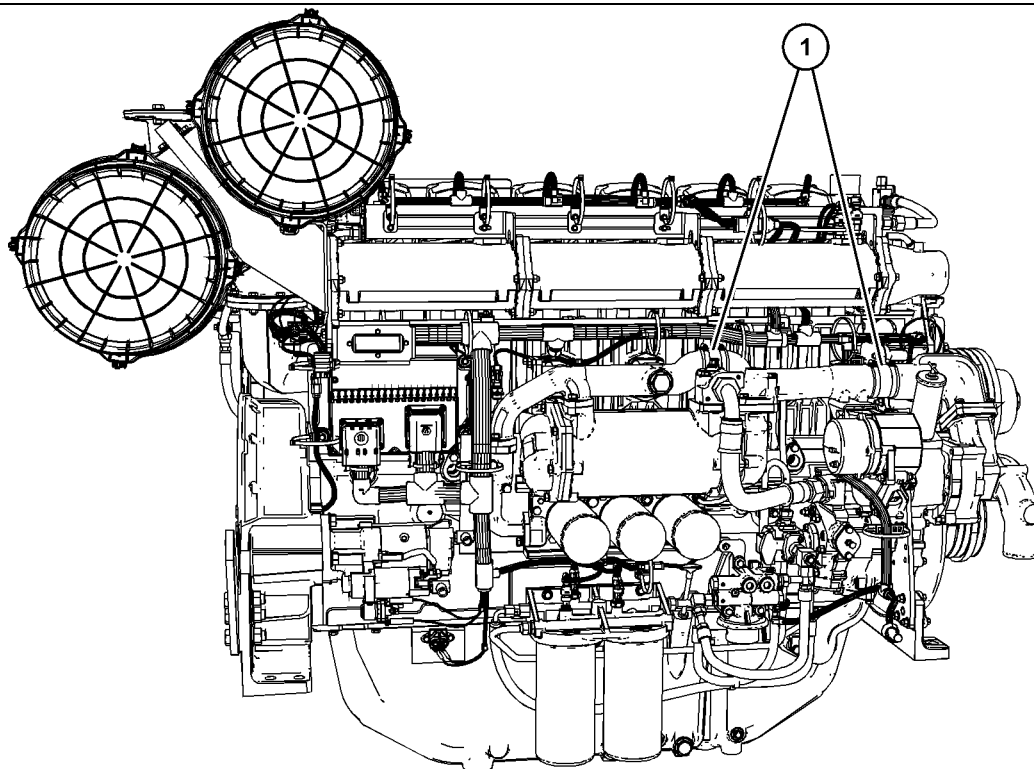

Illustration 114

g06642391

Typical example of an earlier engine

(1) Clamp torque 7 N·m (62 lb in)

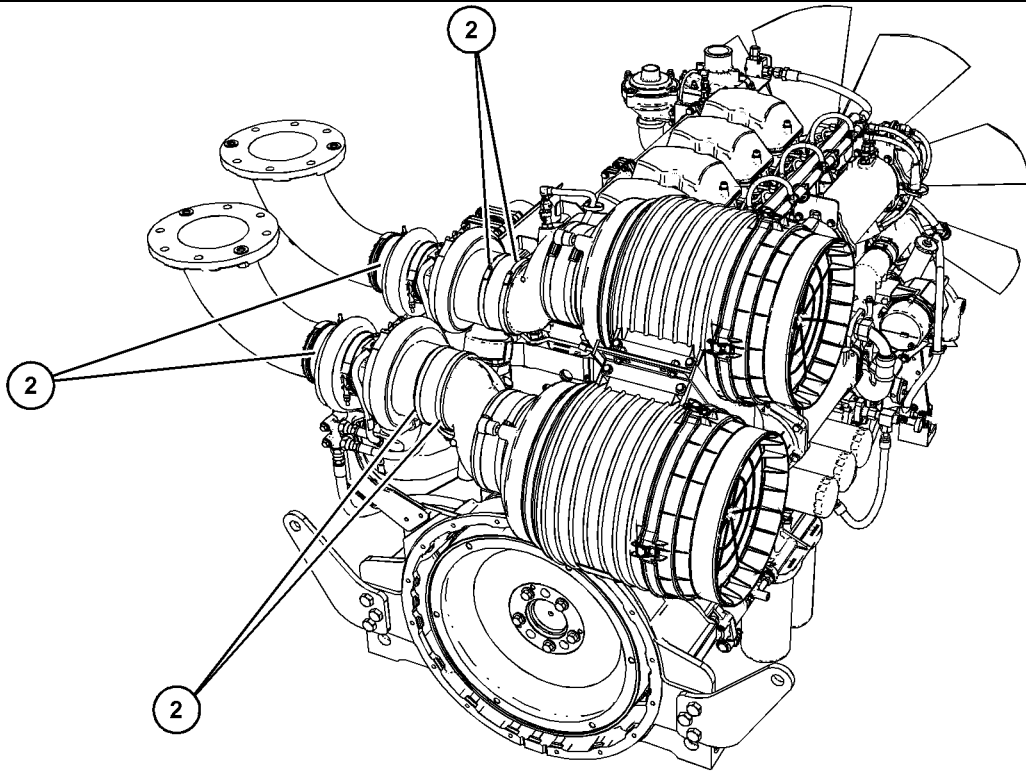
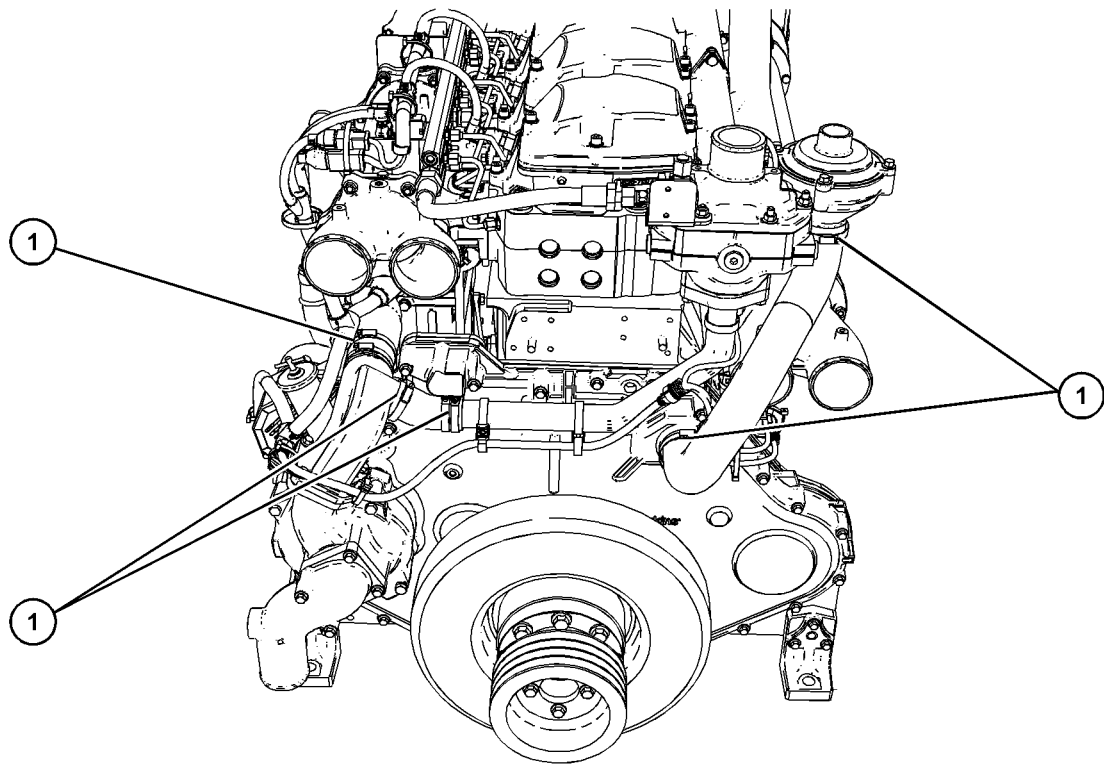

Illustration 115

g07603376

Typical example of an earlier engine

(2) Clamp torque 10 N·m (88.5 lb in)



---

Illustration 116

g06329596

Typical example of an earlier engine

(1) Clamp torque 7 N·m (62 lb in)

## Clamps and V-Band Locations For 8 Cylinder Engines

---

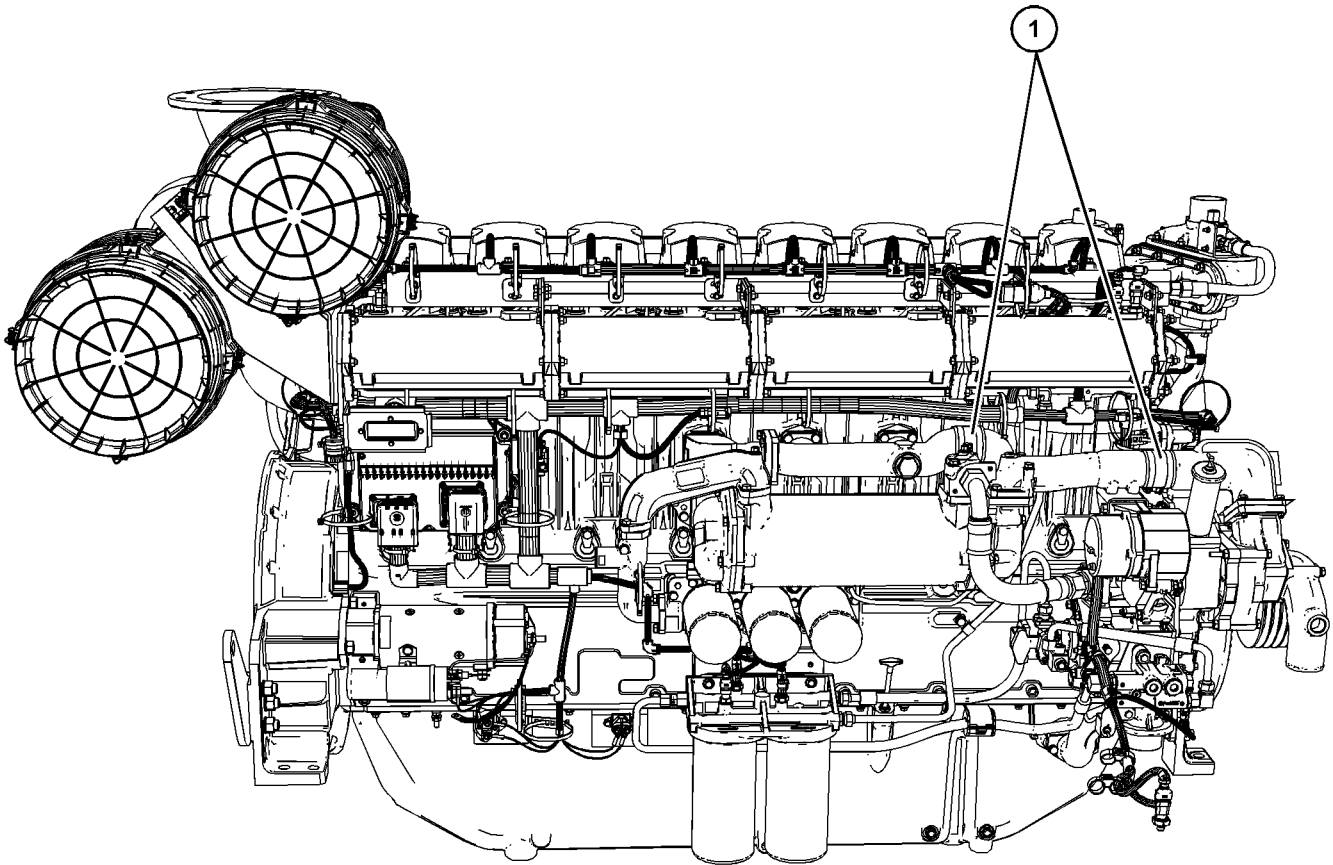

---

Illustration 117

Typical example of an earlier engine

(1) Clamp torque 10 N·m (88.5 lb in)

g06620523

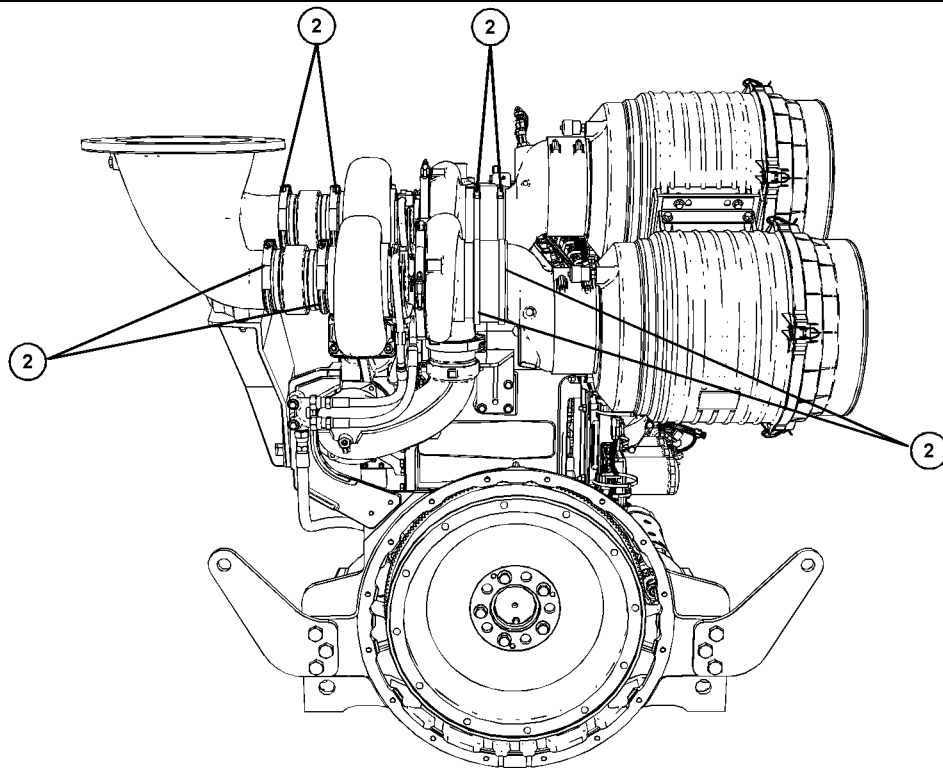

---

Illustration 118

g07603438

Typical example of an earlier engine

(2) Clamp torque 10 N·m (88.5 lb in)

Maintenance Section  
Hoses and Clamps - Inspect/Replace

---

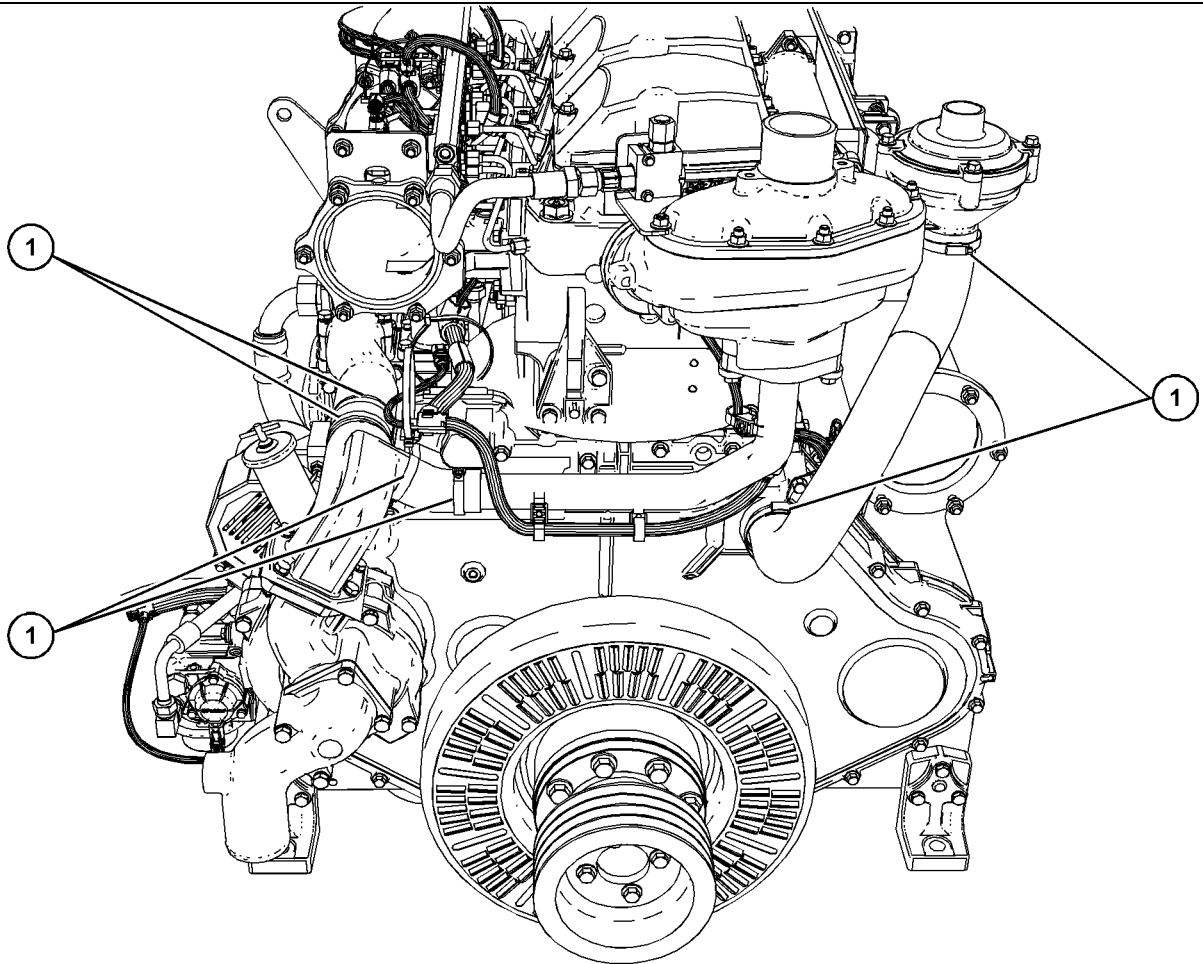

Illustration 119

g06621529

Typical example of an earlier engine

(1) Clamp torque 10 N·m (88.5 lb in)



## Clamps and V-Band Locations for Later Engines

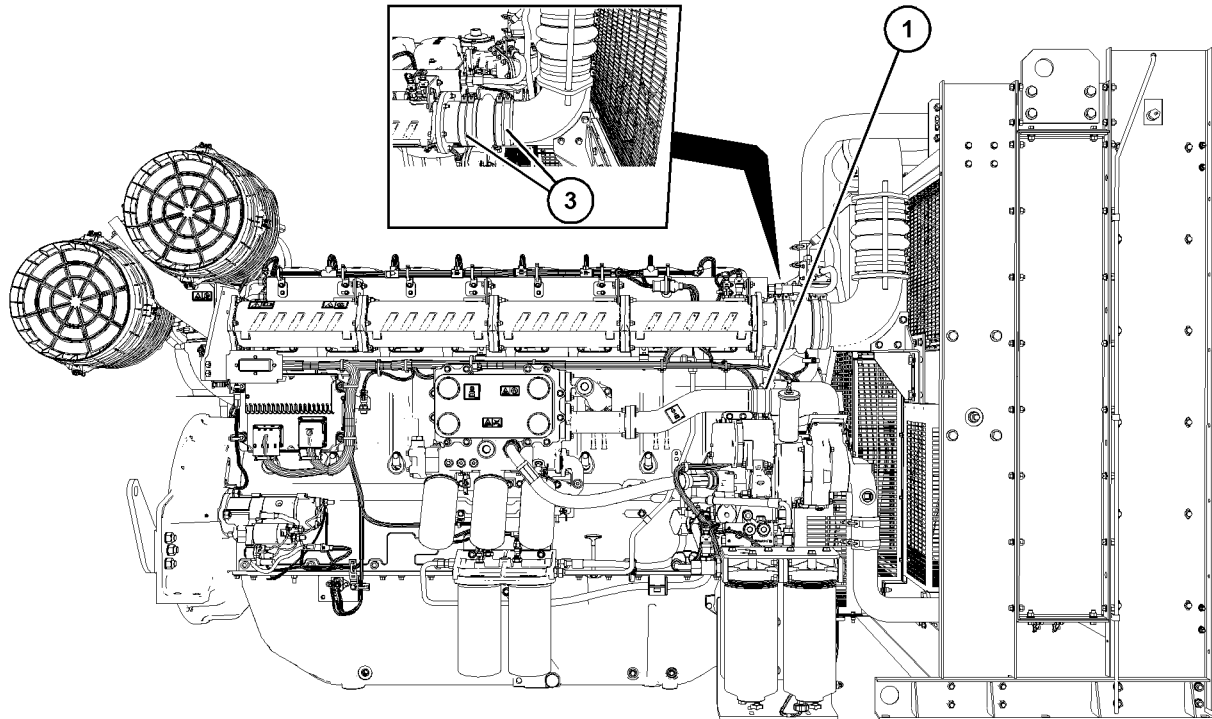

Illustration 120

g07591701

Typical example of a later engine

(1) Clamp torque 10 N·m (88.5 lb in)

(3) Clamp torque 7.5 N·m (66.4 lb in)

Maintenance Section  
Hoses and Clamps - Inspect/Replace

---

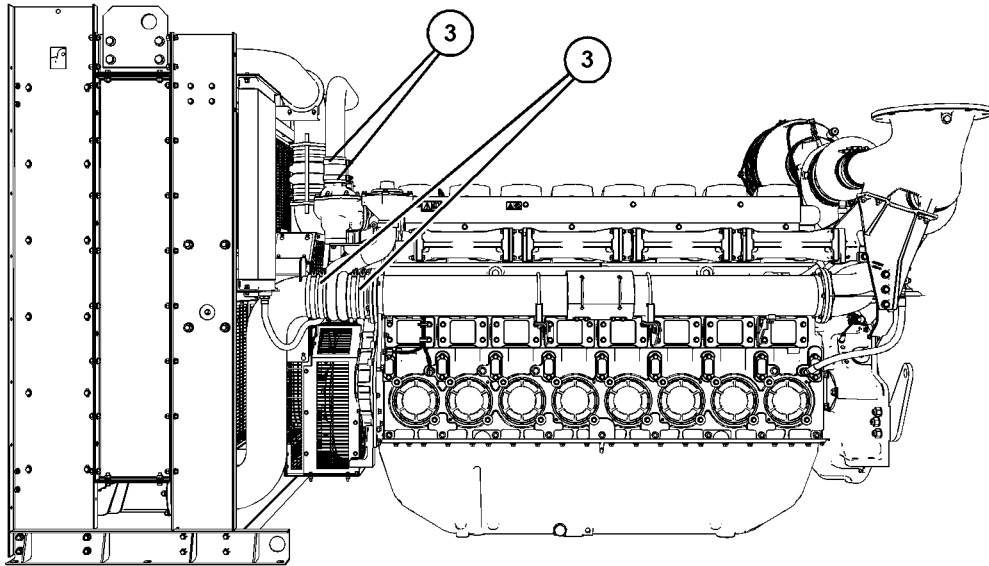

Illustration 121

g07591715

Typical example of a later engine

(3) Clamp torque 7.5 N·m (66.4 lb in)

---

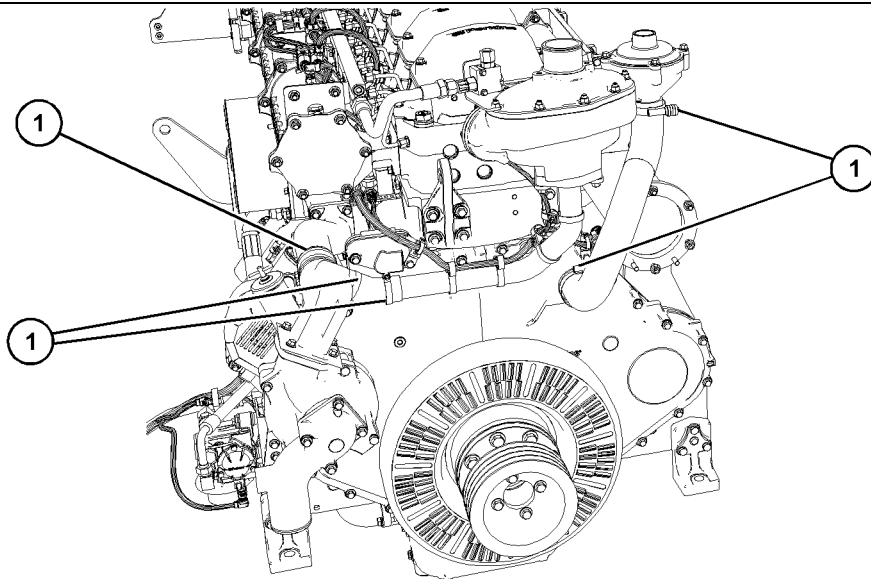

Illustration 122

g07591789

Typical example of a later engine

(1) Clamp torque 7 N·m (62 lb in)

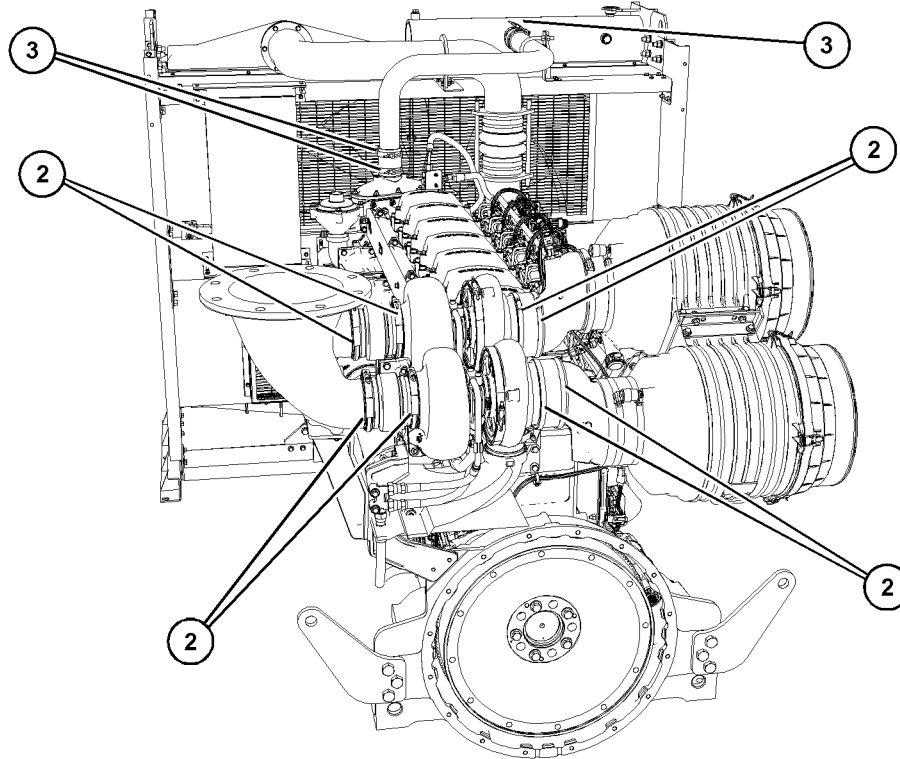

Illustration 123

g07591726

Typical example of a later engine

(2) Clamp torque 10 N·m (88.5 lb in)

(3) Clamp torque 7.5 N·m (66.4 lb in)

## Clamps and V-Band Clamp Torques

Table 12

Clamps and V-band Clamp Torques	
Clamp	Torque
1	7 N·m (62 lb in)
2	10 N·m (88.5 lb in)
3	7.5 N·m (66.4 lb in)

i10002193

## Jacket Water Heater - Check (If Equipped)

Jacket water heaters help to improve starting in ambient temperatures that are below 10 °C (50 °F). All installations that require automatic starting should have jacket water heaters.

Check the operation of the jacket water heater. Check the operation of the circulation pump, if equipped. For ambient temperatures of 10 °C (50 °F) and below, maintain the heater should maintain the jacket water heater temperature at approximately 60 °C (140 °F).

i06530584

## Overhaul (Major)

### Scheduling a Major Overhaul

The need for a major overhaul is determined by several factors:

- An increase of oil consumption
- An increase of crankcase blowby
- A decrease and variation of cylinder compression

Other factors must also be considered for determining a major overhaul:

- The service hours of the engine
- The wear metal analysis of the lube oil

- An increase in the levels of noise and vibration

An increase of wear metals in the lube oil indicates that the bearings and the surfaces that wear may need to be serviced. An increase in the levels of noise and vibration indicates that rotating parts require service.

**Note:** Oil analysis can indicate a decrease of wear metals in the lube oil. The cylinder liners may be worn so that polishing of the bore occurs. Also, the increased use of lube oil will dilute the wear metals.

Monitor the engine as the engine accumulates service hours. Consult Perkins Engines Stafford about scheduling a major overhaul.

**Note:** The driven equipment may also require service when the engine is overhauled. Refer to the literature that is provided by the OEM of the driven equipment.

## Major Overhaul Information

During a major overhaul, all the bearings, seals, joints, and components that wear should be disassembled. The parts should be cleaned. The parts should then be inspected. If necessary, the parts should be replaced. The crankshaft should be inspected and measured for wear. The crankshaft may require regrinding. Alternatively, the crankshaft may be replaced.

## Inspecting Components

Inspect the following components during a major overhaul.

- Radiator and system
- Camshaft
- Camshaft followers
- Connecting rods and bearings
- Crankshaft and bearings
- Gear train
- Inlet air piping
- Oil cooler
- Pistons and rings
- Cylinder liners
- Cylinder heads
- Inlet and exhaust valves

Replace the crankshaft vibration dampers.

i09811855

## Overhaul (Top End)

### Scheduling a Top End Overhaul

Top end overhauls should be scheduled according to the recession of the valve stems. This measurement provides an accurate indication of the rate of valve wear. This measurement can be used to predict when a cylinder head requires replacement.

**Note:** Generally, cylinder heads wear out at different rates. Sometimes, servicing the cylinder heads at different times may be the most economic decision. This action depends on the valve stem projection of the individual cylinders. However, this decision must include the costs of additional downtime that is caused by this procedure. Perform an economic analysis to determine if cylinder heads should be serviced as a group or divided into smaller groups.

### Top End Overhaul Information

A top end overhaul involves servicing the cylinder heads. During a top end overhaul, one piston should be removed. Inspect the piston, piston rings, and the cylinder liner. The condition of these components will determine the period of the major overhaul. Refer to Service Manual for more information.

### Monitoring Valve Seat Wear

Record the engine valve lash, for more information refer to the Operation and Maintenance Manual, "Maintenance Interval Schedule". The monitoring of the valve seat wear should be carried out before any adjustment of the valve lash.

1. Remove the rocker covers.
2. Refer to Systems Operation, Testing and Adjusting, "Valve Lash - Adjust".
3. On all engine cylinders, record the clearance before any adjustments are made.
4. Set the valve bridges.
5. Adjust the valve lash to 0.4 mm (0.016 inch).

The recorded values can be used to identify any excessive valve seat wear on individual valves. The recorded values can be used to schedule a top end overhaul.

An example of recorded valve lash

Table 13

Hours	Recorded clearances on A1 cylinder		Total valve wear	
	Inlet	Exhaust	Inlet	Exhaust
1500	0.35	0.35	0.05	0.05
3000	0.25	0.3	0.35	0.3
4500	0.25	0.3	0.65	0.45

After 4500 hours running, the total wear on the inlet is 0.65 mm (0.026 inch) and the exhaust is 0.45 mm (0.018 inch).

**Note:** Maximum permitted total wear is 3 mm (0.11811 inch).

In this example, the valves are still serviceable after 4500 hours running.

When the valves approach the maximum wear limit, the rockers can be removed and a measurement from the cylinder head face to the top of the valve stems can be taken. When a new valve is installed, the protrusion of the valve stem would be 29.75 mm (1.171 inch). Therefore, a maximum wear limit would be 31.75 mm (1.25 inch).

The valve recession tool has been designed to give service personnel a good indication of the cylinder head valve recession or cylinder head valve seat wear without the need to remove the cylinder heads. For more information contact Perkins distributor.

i09909128

## Radiator - Clean

**Note:** Adjust the frequency of cleaning according to the effects of the operating environment. The radiator and the aftercooler are a combined unit ensure that the aftercooler is also cleaned and inspected.

Inspect the radiator and aftercooler for these items: Damaged fins, corrosion, dirt, grease, insects, leaves, oil, and other debris. Clean the radiator and aftercooler, if necessary.

### WARNING

**Personal injury can result from air pressure.**

**Personal injury can result without following proper procedure. When using pressure air, wear a protective face shield and protective clothing.**

**Maximum air pressure at the nozzle must be less than 205 kPa (30 psi) for cleaning purposes.**

Pressurized air is the preferred method for removing loose debris. Direct the air in the opposite direction to the fans air flow. Hold the nozzle approximately 6 mm (0.25 inch) away from the radiator fins. Slowly move the air nozzle in a direction that is parallel with the radiator tube assembly. This action will remove debris that is between the tubes.

Pressurized water may also be used for cleaning. The maximum water pressure for cleaning purposes must be less than 275 kPa (40 psi). Use pressurized water to soften mud. Clean the core from the front and rear.

Use a degreaser and steam for removal of oil and grease. Clean the front and rear of the core. Wash the core with detergent and hot water. Thoroughly rinse the core with clean water.

After cleaning the radiator and aftercooler, start the engine. Run the engine. This action helps remove debris and the drying of the core. Stop the engine. Use a light bulb behind the core to inspect the core for cleanliness. Repeat the cleaning, if necessary.

Inspect the fins for damage. Bent fins may be opened with a "comb". Inspect these items for good condition: Welds, mounting brackets, air lines, connections, clamps, and seals. Make repairs, if necessary.

i10330334

## Severe Service Application - Check

Severe service is the application of an engine that exceeds the current published standards for that engine. Perkins maintains standards for the following engine parameters:

- Performance such as power range, speed range, and fuel consumption
- Fuel quality
- Operational Altitude
- Maintenance intervals
- Oil selection and maintenance
- Coolant type and maintenance
- Environmental qualities
- Installation
- The temperature of the fluid in the engine
- Cold Starting and Operation

Refer to the standards for the engine or consult your Perkins distributor to determine if the engine is operating within the defined parameters.

Severe service operation can accelerate component wear. Engines that operate under severe conditions may need more frequent maintenance intervals to ensure maximum reliability and retention of full service life.

Perkins engines are unable to identify all the factors which can contribute to severe service operation, due to individual applications. Consult your Perkins distributor or your Perkins distributor for the unique maintenance that is necessary for the engine.

The operating environment, incorrect operating procedures, and incorrect maintenance procedures can be factors which contribute to a severe service application.

Fuel with cleanliness levels from ISO 18 to ISO 21 will require the optional CFM (Clean Fuel Module) equipment to achieve 500hr filter change interval.

For fuel cleanliness of ISO 21 and above a customer supplied fuel pre-cleaner or scrubber will be required to condition the fuel to below the ISO 18 or ISO 21 depending upon the fuel filter option selected.

## Environmental Factors

**Ambient temperatures** – The engine may be exposed to extended operation in extremely cold environments or hot environments. Valve components can be damaged by carbon buildup if the engine is frequently started and stopped in very cold temperatures. Extremely hot intake air reduces engine performance.

**Cold Starting and Operation** – A jacket water heater set at 60 °C (140 °F) should be fitted on applications that are operated in North America (USA and Canada) or the heater should be set at 45 °C (113 °F) for all other regions. The use of a jacket water heater will help with starting in temperatures at the air cleaner inlet of 10 °C (50 °F) down to –18 °C (–0 °F) for North America (USA and Canada) and –30 °C (–22 °F) for all other regions. Additional application starting aids such as ‘room or space heaters’ are required for starting and operation below this temperature. Perkins recommends that site load is applied when the engine reaches rated speed. Refer to “Engine Operation” low load running table of this Operations and Maintenance Manual for more information on low load running. Refer to your Perkins distributor for more information in starting and operation in cold temperatures.

**Quality of the air** – The engine may be exposed to extended operation in an environment that is dirty or dusty, unless the equipment is cleaned regularly. Mud, dirt, and dust can encase components. Maintenance can become very difficult. The buildup can contain corrosive chemicals.

**Buildup** – Compounds, elements, corrosive chemicals, and salt can damage some components.

**Altitude** – Problems can arise when the engine is operated at altitudes that are higher than the intended settings for that application. Necessary adjustments should be made.

## Incorrect Operating Procedures

- Frequent hot shutdowns
- Operating at excessive loads
- Operating at excessive speeds
- Operating outside the intended application

## Incorrect Maintenance Procedures

- Extending the maintenance intervals
- Failure to use recommended fuel, lubricants, and coolant/antifreeze

i07395731

## Starting Motor - Inspect

Perkins recommends a scheduled inspection of the starting motor. If the starting motor fails, the engine may not start in an emergency situation.

Check the starting motor for proper operation. Check the electrical connections and clean the electrical connections. Refer to the Service Manual for more information on the checking procedure and for specifications or consult your Perkins distributors for assistance.

i06532154

## Turbocharger - Inspect

Periodic inspection and cleaning are recommended for the turbochargers. Fouling of the turbine wheels can contribute to loss of engine power and overall loss of engine efficiency.

If a turbocharger fails during engine operation, damage to the turbocharger compressor wheel and/or to the engine may occur. Damage to a turbocharger compressor wheel could allow parts from the compressor wheel to enter an engine cylinder. This debris can damage the pistons, the valves, and the cylinder head.

For information on inspection of the turbocharger, refer to “Systems Operation Testing and Adjusting” Turbocharger.

i08381124

## Walk-Around Inspection

A walk-around inspection should only take a few minutes. When the time is taken to perform these checks, costly repairs and accidents can be avoided.

For maximum engine service life, make a thorough inspection of the engine compartment before starting the engine. Look for items such as oil leaks or coolant leaks, loose bolts, worn belts, loose connections, and trash buildup. Make repairs, as needed:

- The guards must be in the correct place. Repair damaged guards or replace missing guards.
- Wipe all caps and plugs before the engine is serviced to reduce the chance of system contamination.
- Inspect the engine crankcase breather pipe and oil filler tube for damage. Ensure that the tube is clean and free from any obstructions. Ice can cause obstructions in adverse weather conditions.

---

### NOTICE

For any type of leak (coolant, lube, or fuel) clean up the fluid. If leaking is observed, find the source and correct the leak. If leaking is suspected, check the fluid levels more often than recommended until the leak is found or fixed, or until the suspicion of a leak is proved to be unwarranted.

---



---

### NOTICE

Accumulated grease and/or oil on an engine is a fire hazard. Remove the accumulated grease and oil. Refer to Operation and Maintenance Manual, "Engine - Clean" for more information.

---

- Ensure that the cooling system hoses are correctly clamped and that the cooling system hoses are tight. Check for leaks. Check the condition of all pipes.
- Inspect the water pumps for coolant leaks.

**Note:** The water pump seal is lubricated by the coolant in the cooling system. It is normal for a small amount of leakage to occur as the engine cools down and the parts contract.

Excessive coolant leakage may indicate the need to replace a water pump. Refer to Operation and Maintenance Manual, "Water Pump - Inspect" for more information. If necessary, consult your Perkins distributor.

- Inspect the lubrication system for leaks at the front crankshaft seal, the rear crankshaft seal, the oil pan, the oil filters, and the rocker cover.
- Inspect the piping for the air intake system and the elbows for cracks and for loose clamps. Ensure that hoses and tubes are not contacting other hoses, tubes, wiring harnesses, and so forth.
- Ensure that the areas around the rotating parts are clear.
- Inspect the alternator belt and fan drive belts for cracks, breaks, or other damage.
- Check that the fan and belts safety inspection guards are secured in place and not damaged. Replace if necessary. Refer to the OEM information for any procedures that are required to install the inspection guards.
- Inspect the fan blades for damage. Refer to the OEM information for any procedures that are required to install the fan.
- Inspect the wiring harness for damage.

Belts for multiple groove pulleys must be replaced as matched sets. If only one belt is replaced, the belt will carry more load than the belts that are not replaced. The older belts are stretched. The additional load on the new belt could cause the belt to break.

Inspect the exhaust system for leaks or damage. If the exhaust system is equipped with a drain tap, drain any residual liquid into a suitable container. Dispose of the waste liquid in accordance with local regulations and mandates. Refer to the OEM information for any procedures that are required to drain the exhaust system.

i04326852

## Water Pump - Inspect

A failed water pump may cause severe engine overheating problems that could result in the following conditions:

- Cracks in the cylinder head
- A piston seizure
- Other potential damage to the engine

**Note:** The water pump seal is lubricated by the coolant in the cooling system. A normal condition is that a small amount of leakage to occur as the engine cools down and parts contract.

Maintenance Section  
Water Pump - Inspect

---

Visually inspect the water pumps for leaks. The water pumps are not serviceable items. Replace a leaking water pump. Refer to Disassembly and Assembly for more information.



## Warranty Section

## Warranty Information

i06590874

### Emissions Warranty Information

This engine may be certified to comply with exhaust emission and gaseous emission standards that are prescribed by the law at the time of manufacture.

This engine may be covered by an Emissions Warranty. Consult your authorized Perkins dealer or distributor to determine if your engine is emissions certified and if your engine is subject to an Emissions Warranty.

# Index

## A

Additional Messages .....	12
After Stopping Engine .....	53
Aftercooler Core - Clean/Test.....	71
Aftercooler Core - Inspect .....	71
Alternator - Inspect .....	71
Alternator Pulley - Check.....	72

## B

Battery - Replace.....	72
Battery Electrolyte Level - Check .....	73
Battery or Battery Cable - Disconnect.....	73
Before Starting Engine .....	19, 49
Belts - Inspect/Adjust/Replace .....	73
Adjust.....	74
Inspect.....	73
Replace.....	75
Belts - Inspect/Adjust/Replace (5008A- E30TA, 5008C-E30TA, and 5008AC- E30TA Engines Only) .....	75
Adjustment.....	76
Inspection .....	75
Replacement.....	77
Belts - Inspect/Adjust/Replace (Alternator Belt) .....	78
Adjustment.....	79
Inspection .....	78
Replace the Belt .....	79
Burn Prevention.....	16
Batteries.....	17
Coolant .....	16
Diesel Fuel.....	17
Oils.....	16
Viton Seals.....	16

## C

Cold Weather Operation .....	54
Cold Weather Starting.....	50
Configuration Parameters .....	48
System Configuration Parameters .....	48
Cooling System Coolant - Change .....	84
Drain .....	84
Fill using a pump.....	88
Filling from top of the Radiator.....	86
Flush .....	86
Cooling System Coolant (ELC) - Change .....	79
Drain .....	80

Fill using a pump.....	83
Filling from top of the Radiator.....	82
Flush .....	81
Cooling System Coolant Level - Check.....	89
Crankshaft Vibration Damper - Inspect.....	89
Crushing Prevention and Cutting Prevention..	19

## D

Driven Equipment - Check .....	90
--------------------------------	----

## E

Electrical System.....	20
Grounding Practices .....	20
Emergency Stopping.....	53
Emissions Warranty Information .....	121
Engine - Clean.....	90
Engine Air Cleaner Element - Replace .....	90
Engine Air Cleaner Service Indicator - Inspect .....	91
Service Indicator Check.....	91
Service Indicator Reset .....	92
Engine Crankcase Breather - Clean .....	92
Engine Crankcase Breather - Clean/ Replace .....	92
Closed Breather System.....	92
Engine Description .....	28
Aftermarket Products and Perkins Engines .....	30
Electronic Engine Features .....	29
Engine Service Life.....	30
Engine Specifications .....	28
Engine Diagnostics .....	48
Engine Electronics.....	21
Engine Mounts - Inspect.....	94
Engine Oil and Filter - Change .....	97
Drain the Engine Lubricating Oil.....	98
Fill the Oil Pan.....	99
Oil and Filter Change Intervals .....	97
Replace the Oil Filter .....	99
Engine Oil Level - Check.....	94
Engine Oil Pump - Inspect.....	96
Engine Oil Sample - Obtain.....	97
Initiating an Oil analysis Program .....	97
Obtain the Sample and the Analysis .....	97
Engine Operation .....	52
Engine Operation with Intermittent Diagnostic Codes .....	48

Engine Protective Devices - Check (Including Sensor Pack) .....	99	Fuel Storage Tanks.....	105
Visual Inspection.....	100	Fuel Tank .....	105
Engine Starting.....	20, 49	Fuel Transfer Pump (Lift Pump) - Inspect .....	105
Engine Stopping .....	20, 53	<b>G</b>	
Engine Valve Lash - Inspect/Adjust (Valves and Valve Bridges) .....	100	General Hazard Information.....	12
<b>F</b>		Containing Fluid Spillage.....	14
Fan Drive Pulley - Check (5008A-E30TA, 5008C-E30TA, and 5008AC-E30TA Engines Only) .....	100	Dispose of Waste Properly .....	16
Fault Logging.....	48	Fluid Penetration .....	14
Features and Controls.....	38	Inhalation .....	15
Fire Prevention and Explosion Prevention.....	17	Pressurized Air and Water.....	14
Ether .....	18	Static Electricity Hazard when Fueling with Ultra-low Sulfur Diesel Fuel .....	14
Fire Extinguisher.....	18	<b>H</b>	
Lines, Tubes, and Hoses .....	19	Hoses and Clamps - Inspect/Replace.....	105
Fluid Recommendations (Engine Oil Specification).....	59	Clamps and V-Band Clamp Torques .....	115
Engine Oil .....	59	Clamps and V-Band Locations For 6 Cylinder Engines .....	107
General Lubricant Information.....	59	Clamps and V-Band Locations For 8 Cylinder Engines .....	110
Fluid Recommendations (General Coolant Information) .....	56	Clamps and V-Band Locations for Later Engines .....	113
General Coolant Information .....	56	Replace the Hoses and the Clamps .....	106
Fluid Recommendations (General Fuel Information) .....	59	<b>I</b>	
Refill Capacities for the Fuel System.....	59	Important Safety Information.....	2
Foreword .....	4	<b>J</b>	
California Proposition 65 Warning.....	4	Jacket Water Heater - Check (If Equipped) ...	115
Literature Information .....	4	<b>L</b>	
Maintenance .....	4	Lifting and Storage .....	33
Maintenance Intervals .....	5	<b>M</b>	
Operation .....	4	Maintenance Interval Schedule.....	63, 65, 67, 69
Overhaul .....	5	Maintenance Interval Schedule (50Hz Engines in Standby Applications)	
Safety.....	4	Daily or Prior to Starting Stand-by Unit.....	63
Fuel and the Effect from Cold Weather.....	54	Every 1500 Service Hours.....	63
Fuel Conservation Practices .....	52	Every 2000 Service Hours.....	64
Fuel Injector - Inspect/Adjust.....	101	Every 3000 Service Hours.....	64
Fuel Injector - Replace .....	101	Every 4000 Service Hours.....	64
Fuel Related Components in Cold Weather ...	54	Every 6000 Service Hours or 3 Years .....	64
Fuel Heaters .....	54	Every 750 Service Hours or 2 Years or Prior to Functional Load Test.....	63
Fuel Tanks .....	54	Every 7500 Service Hours.....	64
Fuel System - Prime .....	101		
Fuel System Primary Filter - Replace .....	102		
Fuel System Primary Filter/Water Separator - Drain .....	103		
Fuel System Secondary Filter - Replace .....	104		
Fuel Tank Water and Sediment - Drain .....	105		
Drain the Water and the Sediment .....	105		

Initial 750 Service Hours or 2 Years .....	63	Warning Alarm .....	38
When Required.....	63	Mounting and Dismounting .....	19
Maintenance Interval Schedule (60Hz Engines in Standby Applications)		<b>O</b>	
Daily or Prior to Starting Stand-by Unit.....	69	Operation Section.....	33
Every 1500 Service Hours.....	69	Overhaul (Major) .....	115
Every 2000 Service Hours.....	70	Major Overhaul Information.....	116
Every 3000 Service Hours.....	70	Scheduling a Major Overhaul .....	115
Every 4000 Service Hours.....	70	Overhaul (Top End) .....	116
Every 500 Service Hours or 2 Years or Prior to Functional Load Test.....	69	Scheduling a Top End Overhaul.....	116
Every 6000 Service Hours or 3 Years .....	70	Top End Overhaul Information.....	116
Every 7500 Service Hours.....	70	<b>P</b>	
Initial 250 Service Hours or 1 Year .....	69	Plate Locations and Film Locations .....	31
When Required.....	69	Emission Label .....	32
Maintenance Interval Schedule (Engines in Base Load Applications)		Product Identification Information .....	31
Daily .....	67	Product Information Section.....	22
Every 1500 Service Hours.....	67	Product Lifting .....	33
Every 20 000 Service Hours .....	68	Engine Only - Earlier Engines .....	33
Every 3000 Service Hours.....	67	Later engines.....	34
Every 40 000 Service Hours.....	68	Radiator Only.....	34
Every 6000 Service Hours.....	67	Product Storage .....	35
Every 750 Service Hours.....	67	Condition for Storage.....	35
Every 7500 Service Hours.....	67	Engine.....	36
Initial 750 Service Hours.....	67	<b>R</b>	
When Required.....	67	Radiator - Clean .....	117
Maintenance Interval Schedule (Engines in Prime Power Applications)		Refill Capacities.....	56
Daily .....	65	<b>Cooling System</b> .....	56
Every 15 000 Service Hours .....	66	<b>Fuel System</b> .....	56
Every 1500 Service Hours.....	65	<b>Lubrication System</b> .....	56
Every 30 000 Service Hours .....	66	<b>S</b>	
Every 3000 Service Hours.....	65	Safety Messages.....	6
Every 6000 Service Hours.....	65	1 Universal Warning .....	9
Every 750 Service Hours.....	65	2 Do Not Step .....	9
Every 7500 Service Hours.....	65	3 Electrocution.....	10
Initial 750 Service Hours.....	65	4 Hot Fluid Under Pressure .....	10
When Required.....	65	5 Hot Surface.....	11
Maintenance Recommendations .....	62	6 Ether Warning.....	11
Maintenance Section.....	56	7 Rotating Shaft Hand Crush Hazard .....	11
Model View Illustrations .....	22	Safety Section .....	6
Engine Views .....	22	Self-Diagnostics .....	48
Radiator View .....	24	Sensors and Electrical Components (Electrical Components).....	45
Model Views .....	22	Sensors and Electrical Components (Sensors Only).....	39
Monitoring System.....	38	Earlier Engine Sensor Views.....	40
Critical Protection Override.....	38		
Diagnostic.....	39		
Shutdown.....	38		
Shutdown Reset .....	39		
Standard Warning Outputs .....	39		

Later Engine Sensor Views .....	43
Severe Service Application .....	62
Environmental Factors.....	62
Incorrect Maintenance Procedures .....	62
Incorrect Operating Procedures .....	62
Severe Service Application - Check.....	117
Environmental Factors.....	118
Incorrect Maintenance Procedures .....	118
Incorrect Operating Procedures .....	118
Starting Motor - Inspect .....	118
Starting the Engine.....	49
Alternative Engine Starting Procedure .....	50
Normal Engine Starting Procedure.....	49
Stopping the Engine .....	53

**T**

Table of Contents .....	3
Turbocharger - Inspect.....	118

**W**

Walk-Around Inspection .....	119
Warranty Information.....	121
Warranty Section .....	121
Water Pump - Inspect.....	119



# Product and Dealer Information

Note: For product identification plate locations, see the section "Product Identification Information" in the Operation and Maintenance Manual.

Delivery Date: \_\_\_\_\_

## Product Information

Model: \_\_\_\_\_

Product Identification Number: \_\_\_\_\_

Engine Serial Number: \_\_\_\_\_

Transmission Serial Number: \_\_\_\_\_

Generator Serial Number: \_\_\_\_\_

Attachment Serial Numbers: \_\_\_\_\_

Attachment Information: \_\_\_\_\_

Customer Equipment Number: \_\_\_\_\_

Dealer Equipment Number: \_\_\_\_\_

## Dealer Information

Name: \_\_\_\_\_ Branch: \_\_\_\_\_

Address: \_\_\_\_\_

\_\_\_\_\_

\_\_\_\_\_

Dealer Contact

Phone Number

Hours

Sales: \_\_\_\_\_

Parts: \_\_\_\_\_

Service: \_\_\_\_\_

