



# 330

## Hydraulic Excavator

# Technical Specifications

Configurations and features may vary by region. Please consult your Cat® dealer for availability in your area.

## Table of Contents

<b>Specifications</b> .....	<b>2</b>
Engine .....	2
Swing Mechanism .....	2
Weights .....	2
Track .....	2
Drive .....	2
Hydraulic System .....	2
Service Refill Capacities .....	2
Standards .....	3
Sound Performance .....	3
Operating Weights and Ground Pressures .....	3
Major Component Weights .....	4
Dimensions .....	5
Working Ranges and Forces .....	7
Reach Boom Lift Capacities .....	9
Super Long Reach (SLR) Boom Lift Capacities .....	19
Bucket Specifications and Compatibility .....	21
Attachments Offering Guide .....	24
Thumb Specifications .....	31
<b>Standard and Optional Equipment</b> .....	<b>32</b>
<b>Cab Options</b> .....	<b>34</b>
<b>Dealer Installed Kits and Attachments</b> .....	<b>35</b>
<b>330 Environmental Declaration</b> .....	<b>36</b>

# 330 Hydraulic Excavator Specifications

## Engine

Engine Model	Cat® C7.1	
Net Power		
ISO 9249	203.7 kW	273 hp
ISO 9249 (DIN)	277 hp (metric)	
Engine Power		
ISO 14396	205 kW	275 hp
ISO 14396 (DIN)	279 hp (metric)	
Bore	105 mm	4 in
Stroke	135 mm	5 in
Displacement	7.01 L	428 in <sup>3</sup>
Biodiesel capability	Up to B20 <sup>(1)</sup>	

- Meets U.S. EPA Tier 4 Final, EU Stage V, Korea Stage V, and Japan 2014 emission standards.
- Recommended for use up to 4500 m (14,760 ft) altitude with engine power derate above 3000 m (9,840 ft).
- Advertised power is tested per the specified standard in effect at the time of manufacture.
- Net power advertised is the power available at the flywheel when the engine is equipped with fan, air intake system, exhaust system and alternator.
- Engine speed at 2,200 rpm.

<sup>(1)</sup>Cat diesel engines are required to use ULSD (ultra-low sulfur diesel fuel with 15 ppm of sulfur or less) or ULSD blended with the following lower-carbon intensity fuels\*\* up to:

- ✓ 20% biodiesel FAME (fatty acid methyl ester)\*
- ✓ 100% renewable diesel, HVO (hydrogenated vegetable oil) and GTL (gas-to-liquid) fuels

Refer to guidelines for successful application. Please consult your Cat dealer or “Caterpillar Machine Fluids Recommendations” (SEBU6250) for details.

*\*Engines with no aftertreatment devices can use higher blends, up to 100% biodiesel (for use of blends higher than 20% biodiesel, consult your Cat dealer).*

*\*\*Tailpipe greenhouse gas emissions from lower-carbon intensity fuels are essentially the same as traditional fuels.*

## Swing Mechanism

Swing Speed	11.5 rpm	
Maximum Swing Torque	110 kN·m	81,132 lbf·ft

## Weights

Operating Weight	31 400 kg	69,200 lb
------------------	-----------	-----------

- Long undercarriage, Reach boom, R3.2 m (10'6") stick, Heavy Duty (HD) 1.76 m<sup>3</sup> (2.30 yd<sup>3</sup>) bucket, 800 mm (31") triple grouser shoes and 6700 kg (14,770 lb) counterweight.

Operating Weight	31 400 kg	69,200 lb
------------------	-----------	-----------

- Long undercarriage, Straight boom, R3.75 m (12'4") stick + HD 1.54 m<sup>3</sup> (2.01 yd<sup>3</sup>) bucket, 800 mm (31") triple grouser shoes and 6700 kg (14,770 lb) counterweight.

## Track

Standard Track Shoes Width	800 mm	31 in
Optional Track Shoes Width	600 mm	24 in
Optional Track Shoes Width	700 mm	28 in
Number of Shoes (each side)	50	
Number of Track Rollers (each side)	9	
Number of Carrier Rollers (each side)	2	

## Drive

Gradeability	35°/70%	
Maximum Travel Speed	5.3 km/h	3.3 mph
Maximum Drawbar Pull	248 kN	55,753 lbf

## Hydraulic System

Main System – Maximum Flow – Implement	560 L/min (280 × 2 pumps)	148 gal/min (74 × 2 pumps)
Maximum Pressure – Equipment – Normal	35 000 kPa	5,075 psi
Maximum Pressure – Equipment – Heavy Lift Mode/Auto Dig Boost	38 000 kPa	5,510 psi
Maximum Pressure – Travel	35 000 kPa	5,075 psi
Maximum Pressure – Swing	29 800 kPa	4,320 psi
Boom Cylinder – Bore	140 mm	6 in
Boom Cylinder – Stroke	1407 mm	55 in
Stick Cylinder – Bore	150 mm	6 in
Stick Cylinder – Stroke	1646 mm	65 in
Bucket Cylinder – Bore	135 mm	5 in
Bucket Cylinder – Stroke	1156 mm	46 in

## Service Refill Capacities

Fuel Tank Capacity	474 L	125.2 gal
Cooling System	25 L	6.6 gal
Engine Oil	25 L	6.6 gal
Swing Drive	10 L	2.6 gal
Final Drive (each)	5.5 L	1.5 gal
Hydraulic System (including tank)	310 L	81.9 gal
Hydraulic Tank	147 L	38.8 gal
Diesel Exhaust Fluid (DEF) Tank	41 L	10.8 gal

# 330 Hydraulic Excavator Specifications

## Standards

Brakes	ISO 10265:2008
Cab/Rollover Protective Structure (ROPS)	ISO 12117-2:2008
Operator Protective Guards (OPG)* (optional)	ISO 10262:1998 Level II

\*Mandatory for Straight boom configuration.

## Sound Performance

ISO 6395:2008 (external)	103 dB(A)
ISO 6396:2008 (inside cab)	70 dB(A)

- Hearing protection may be needed when operating with an open operator station and cab (when not properly maintained or doors/windows open) for extended periods or in a noisy environment.

## Operating Weights and Ground Pressures

	800 mm (31") Triple Grouser Shoes		700 mm (28") HD Triple Grouser Shoes		600 mm (24") Single Grouser Shoes	
	Weight	Ground Pressure	Weight	Ground Pressure	Weight	Ground Pressure
	kg (lb)	kPa (psi)	kg (lb)	kPa (psi)	kg (lb)	kPa (psi)
<b>Base Machine Configurations</b>						
<b>Base Frame with Track Rollers and Carrier Rollers</b>						
<b>6700 kg (14,770 lb) Counterweight and Long Undercarriage Base Machine</b>						
Reach Boom + R3.2CB2 (10'6") Stick + 1.76 m <sup>3</sup> (2.30 yd <sup>3</sup> ) HD Bucket	31 400 (69,200)	45 (6.5)	31 000 (68,400)	51 (7.3)	30 700 (67,700)	58 (8.5)
Reach Boom + R3.75CB2 (12'4") Stick + 1.76 m <sup>3</sup> (2.30 yd <sup>3</sup> ) HD Bucket	31 600 (69,700)	45 (6.5)	31,200 (68,800)	51 (7.4)	30 900 (68,100)	59 (8.5)
Straight Boom + R3.75CB2 (12'4") Stick + 1.54 m <sup>3</sup> (2.01 yd <sup>3</sup> ) HD Bucket	31 400 (69,200)	45 (6.5)	31 100 (68,600)	51 (7.4)	30 700 (67,700)	58 (8.5)
Super Long Reach (SLR) Boom + SLR 7.85A (25'9") Stick + 0.57 m <sup>3</sup> (0.75 yd <sup>3</sup> ) Ditch Cleaning (DC) Bucket	31 400 (69,200)	45 (6.5)	31 000 (68,400)	51 (7.3)	30 700 (67,700)	58 (8.5)

All operating weights include a 90% fuel tank with 75 kg (165 lb) operator.

# 330 Hydraulic Excavator Specifications

## Major Component Weights

	kg	lb
Base Machine Weight (with 6700 kg [14,770 lb] counterweight, upper frame, long undercarriage with HD track rollers and two boom cylinders) – does not include weight of 90% fuel tank and 75 kg (165 lb) operator.	21 200	46,700
Track Shoes:		
800 mm (31") Width, 13 mm (0.51") Thick, Triple Grouser Track Shoes with Step Extension	4590	10,120
700 mm (28") Width, 13 mm (0.51") Thick, HD Triple Grouser Track Shoes	4200	9,260
600 mm (24") Width, 15 mm (0.59") Thick, Single Grouser Track Shoes	3890	8,580
Two Boom Cylinders	490	1,080
Weight of 90% Fuel Tank and 75 kg (165 lb) Operator	460	1,010
Counterweight:		
6700 kg (14,770 lb) Counterweight	6700	14,770
Undercarriage (without track shoes):		
Long Undercarriage with HD Rollers	6700	14,800
Booms (including lines, pins, stick cylinder):		
Reach Boom 6.15 m (20'2")	2310	5,090
Straight Boom 6.5 m (21'4")	2390	5,300
Super Long Reach Boom 10.2 m (33'6")	3200	7,050
Sticks (including lines, pins, bucket cylinder, bucket linkage):		
Reach Stick R3.2CB2 (10'6")	1470	3,240
Reach Stick R3.75CB2 (12'4")	1660	3,660
Super Long Reach Stick 7.85A (25'9")	1560	3,440
Bucket Cylinder Guard for Reach Stick	190	400
Buckets (without linkage, with tips and sidecutters):		
0.91 m <sup>3</sup> (1.19 yd <sup>3</sup> ) HD, CB Linkage	950	2,100
1.12 m <sup>3</sup> (1.46 yd <sup>3</sup> ) HD, CB Linkage	1040	2,300
1.33 m <sup>3</sup> (1.74 yd <sup>3</sup> ) HD, CB Linkage	1160	2,560
1.54 m <sup>3</sup> (2.01 yd <sup>3</sup> ) HD, CB Linkage	1130	2,500
1.76 m <sup>3</sup> (2.30 yd <sup>3</sup> ) HD, CB Linkage	1350	2,980
0.57 m <sup>3</sup> (0.75 yd <sup>3</sup> ) Ditch Cleaning (DC), A Linkage	390	900
Quick Couplers (QC):		
Pin Grabber QC CB with Pins	530	1,170
Pin Grabber QC CB without Pins	500	1,100
Dedicated QC	430	950

# 330 Hydraulic Excavator Specifications

## Dimensions

All dimensions are approximate and may vary depending on bucket selection.

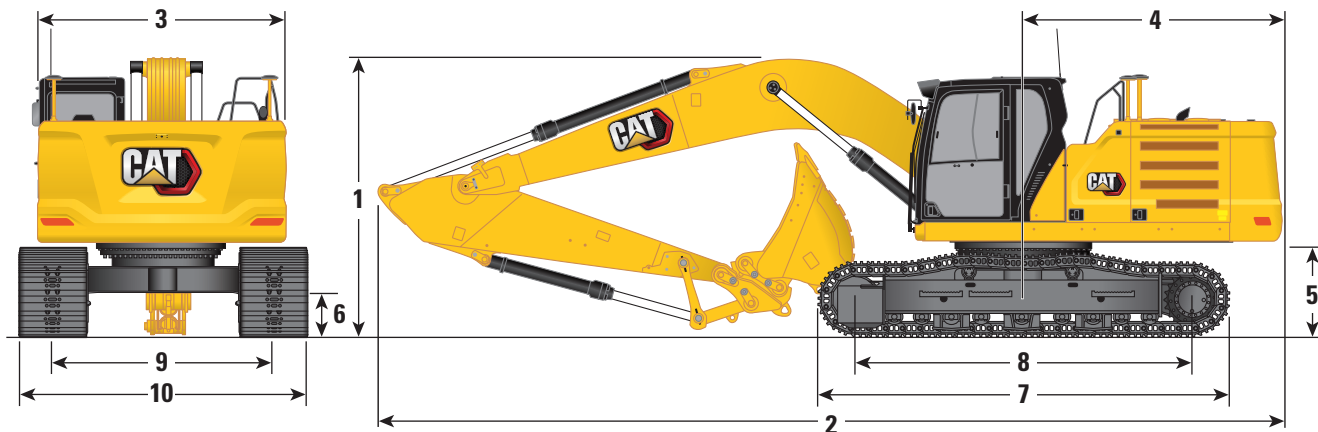

### Boom Options

Reach Boom  
6.15 m (20'2")

### Stick Options

Reach Stick

R3.2CB2 (10'6")

R3.75CB2 (12'4")

#### 1 Machine Height:

	R3.2CB2 (10'6")		R3.75CB2 (12'4")	
Cab Height	3060 mm	10'0"	3060 mm	10'0"
Top of Global Navigation Satellite System (GNSS) Antenna Height (if installed)	3080 mm	10'1"	3080 mm	10'1"
OPG Height	3200 mm	10'6"	3200 mm	10'6"
Handrail Height	3060 mm	10'0"	3060 mm	10'0"
With Boom/Stick/Bucket Installed	3400 mm	11'2"	3700 mm	12'2"
With Boom/Stick Installed	3380 mm	11'1"	3700 mm	12'2"
With Boom Installed	3060 mm	10'0"	3060 mm	10'0"

#### 2 Machine Length:

With Boom/Stick/Bucket Installed	10 420 mm	34'2"	10 420 mm	34'2"
With Boom/Stick Installed	10 420 mm	34'2"	10 420 mm	34'2"
With Boom Installed	9230 mm	30'3"	9230 mm	30'3"

#### 3 Upperframe Width

	2940 mm	9'8"	2940 mm	9'8"
--	---------	------	---------	------

#### 4 Tail Swing Radius

	3130 mm	10'3"	3130 mm	10'3"
--	---------	-------	---------	-------

#### 5 Counterweight Clearance

	1120 mm	3'8"	1120 mm	3'8"
--	---------	------	---------	------

#### 6 Ground Clearance

	490 mm	1'7"	490 mm	1'7"
--	--------	------	--------	------

#### 7 Track Length

	4860 mm	15'11"	4860 mm	15'11"
--	---------	--------	---------	--------

#### 8 Length to Center of Rollers

	3990 mm	13'1"	3990 mm	13'1"
--	---------	-------	---------	-------

#### 9 Track Gauge

	2590 mm	8'6"	2590 mm	8'6"
--	---------	------	---------	------

#### 10 Undercarriage Width:

600 mm (24") Shoes	3190 mm	10'6"	3190 mm	10'6"
700 mm (28") Shoes	3290 mm	10'10"	3290 mm	10'10"
800 mm (31") Shoes	3390 mm	11'1"	3390 mm	11'1"

#### Bucket Type

HD

HD

Bucket Capacity	1.76 m <sup>3</sup>	2.30 yd <sup>3</sup>	1.76 m <sup>3</sup>	2.30 yd <sup>3</sup>
Bucket Tip Radius	1660 mm	5'5"	1660 mm	5'5"

# 330 Hydraulic Excavator Specifications

## Dimensions

All dimensions are approximate and may vary depending on bucket selection.

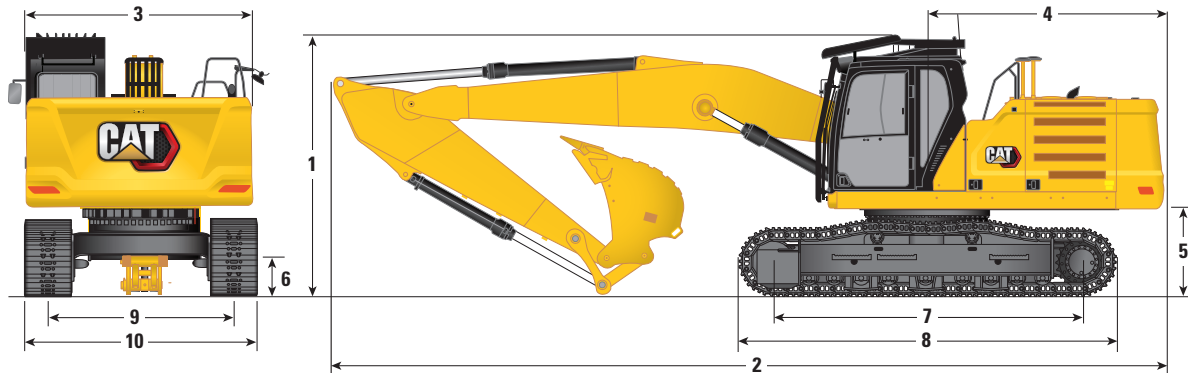

Boom Option	Straight Boom 6.5 m (21'4")				SLR Boom 10.2 m (33'6")	
	Reach Stick				SLR Stick 7.85A (25'9")	
Stick Options	R3.2CB2 (10'6")		R3.75CB2 (12'4")		7.85A (25'9")	
<b>1 Machine Height:</b>						
Cab Height (demolition OPG installed)	3370 mm	11'1"	3370 mm	11'1"	3060 mm	10'0"
Cab Height (demolition OPG removed)	3060 mm	10'0"	3060 mm	10'0"	3080 mm	10'1"
Top of GNSS Antenna Height (if installed)	3080 mm	10'1"	3080 mm	10'1"	3200 mm	10'6"
Handrail Height	3060 mm	10'0"	3060 mm	10'0"	3060 mm	10'0"
With Boom/Stick/Bucket Installed	3370 mm	11'1"	3640 mm	11'11"	3230 mm	10'7"
With Boom/Stick Installed	3370 mm	11'1"	3370 mm	11'1"	3230 mm	10'7"
With Boom Installed	3370 mm	11'1"	3370 mm	11'1"	3060 mm	10'0"
<b>2 Machine Length:</b>						
With Boom/Stick/Bucket Installed	10 675 mm	35'0"	10 580 mm	34'9"	14 480 mm	47'6"
With Boom/Stick Installed	10 720 mm	35'2"	10 690 mm	35'1"	14 480 mm	47'6"
With Boom Installed	9550 mm	31'4"	9550 mm	31'4"	13 390 mm	43'11"
<b>3 Upperframe Width</b>	2940 mm	9'8"	2940 mm	9'8"	2940 mm	9'8"
<b>4 Tail Swing Radius</b>	3130 mm	10'3"	3130 mm	10'3"	3130 mm	10'3"
<b>5 Counterweight Clearance</b>	1120 mm	3'8"	1120 mm	3'8"	1120 mm	3'8"
<b>6 Ground Clearance</b>	490 mm	1'7"	490 mm	1'7"	490 mm	1'7"
<b>7 Length to Center of Rollers</b>	3990 mm	13'1"	3990 mm	13'1"	4860 mm	15'11"
<b>8 Track Length</b>	4860 mm	15'11"	4860 mm	15'11"	3990 mm	13'1"
<b>9 Track Gauge</b>	2590 mm	8'6"	2590 mm	8'6"	2590 mm	8'6"
<b>10 Undercarriage Width</b>						
600 mm (24") Shoes	3190 mm	10'6"	3190 mm	10'6"	3190 mm	10'6"
700 mm (28") Shoes	3290 mm	10'10"	3290 mm	10'10"	3290 mm	10'10"
800 mm (31") Shoes	3390 mm	11'1"	3390 mm	11'1"	3390 mm	11'1"
Bucket Type	HD		HD		DC	
Bucket Capacity	1.54 m <sup>3</sup>	2.01 yd <sup>3</sup>	1.54 m <sup>3</sup>	2.01 yd <sup>3</sup>	0.57 m <sup>3</sup>	0.75 yd <sup>3</sup>
Bucket Tip Radius	1658 mm	5'5"	1658 mm	5'5"	1090 mm	3'7"

# 330 Hydraulic Excavator Specifications

## Working Ranges and Forces

All dimensions are approximate and may vary depending on bucket selection.

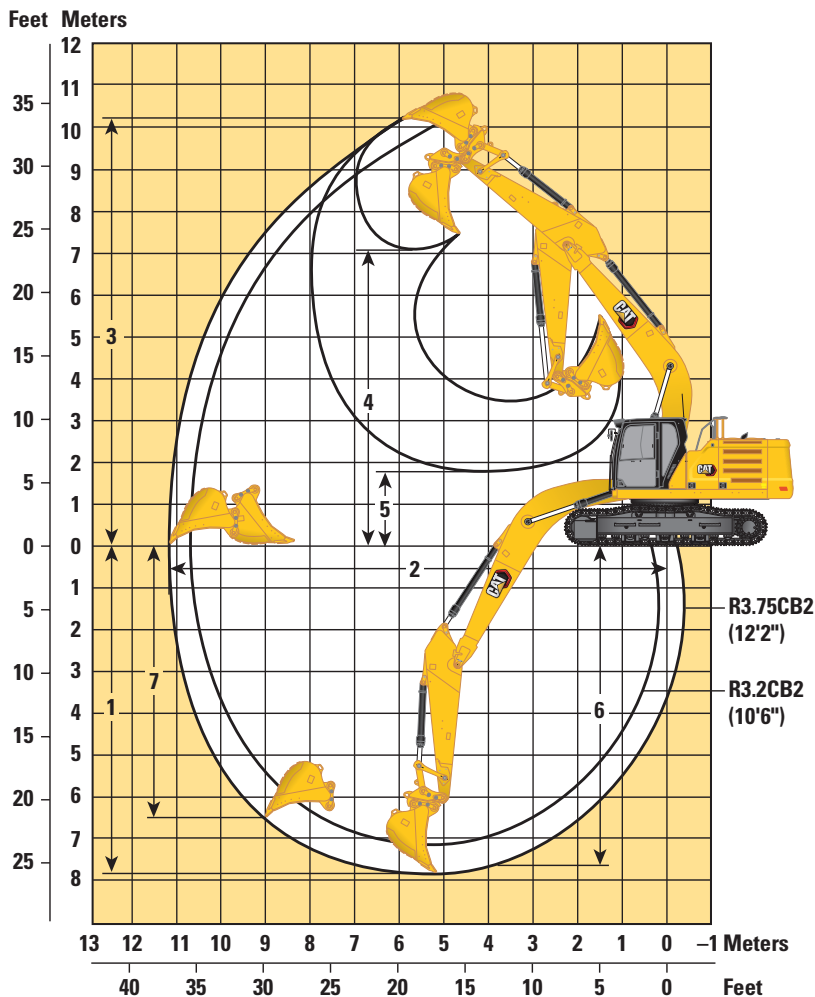

### Boom Options

Reach Boom  
6.15 m (20'2")

### Stick Options

Reach Stick

R3.2CB2 (10'6")

R3.75CB2 (12'4")

	R3.2CB2 (10'6")		R3.75CB2 (12'4")	
<b>1</b> Maximum Digging Depth	7240 mm	23'9"	7790 mm	25'7"
<b>2</b> Maximum Reach at Ground Line	10 680 mm	35'0"	11 190 mm	36'9"
<b>3</b> Maximum Cutting Height	10 030 mm	32'11"	10 210 mm	33'6"
<b>4</b> Maximum Loading Height	6950 mm	22'10"	7140 mm	23'5"
<b>5</b> Minimum Loading Height	2300 mm	7'7"	1750 mm	5'9"
<b>6</b> Maximum Depth Cut for 2440 mm (8 ft) Level Bottom	7090 mm	23'3"	7650 mm	25'1"
<b>7</b> Maximum Vertical Wall Digging Depth	6010 mm	19'9"	6450 mm	21'2"
Bucket Digging Force (ISO)	179 kN	40,240 lbf	179 kN	40,240 lbf
Stick Digging Force (ISO)	126 kN	28,330 lbf	114 kN	25,630 lbf
Bucket Digging Force (ISO) – Auto Dig Boost	189 kN	42,480 lbf	189 kN	42,480 lbf
Stick Digging Force (ISO) – Auto Dig Boost	133 kN	29,900 lbf	120 kN	27,050 lbf
Bucket Type	HD		HD	
Bucket Capacity	1.76 m <sup>3</sup>	2.30 yd <sup>3</sup>	1.76 m <sup>3</sup>	2.30 yd <sup>3</sup>
Bucket Tip Radius	1660 mm	5'5"	1660 mm	5'5"

# 330 Hydraulic Excavator Specifications

## Working Ranges and Forces

All dimensions are approximate and may vary depending on bucket selection.

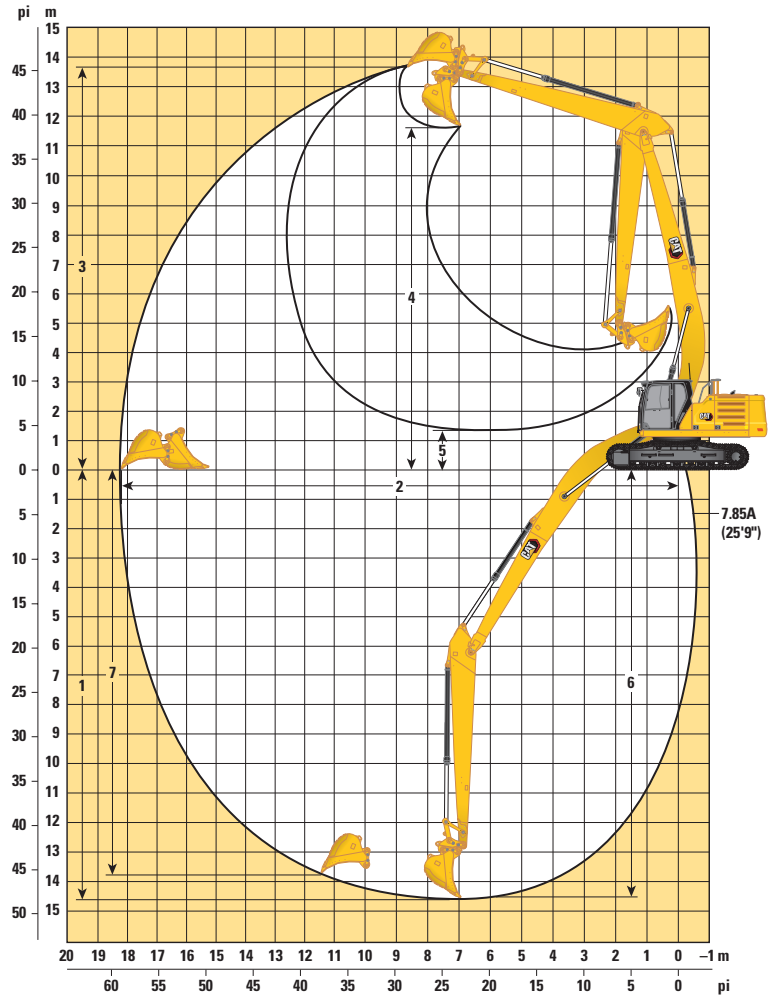
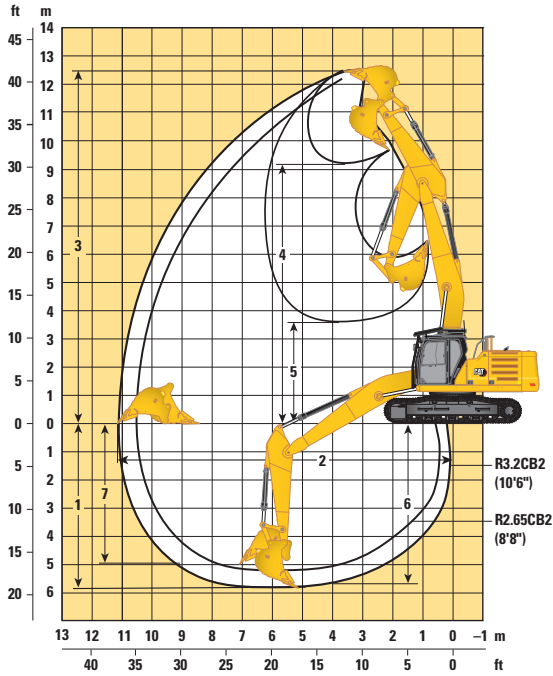

### Boom Options

Straight Boom 6.5 m (21'3")

SLR Boom  
10.2 m (33'6")

### Stick Options

Reach Stick

SLR Stick  
7.85A (25'9")

R3.2CB2 (10'6")

R3.75CB2 (12'4")

	R3.2CB2 (10'6")		R3.75CB2 (12'4")		7.85A (25'9")	
1 Maximum Digging Depth	5810 mm	19'1"	6360 mm	20'10"	14 610 mm	47'11"
2 Maximum Reach at Ground Line	11 190 mm	36'9"	11 710 mm	38'5"	18 290 mm	60'0"
3 Maximum Cutting Height	12 480 mm	40'11"	12 890 mm	42'3"	13 590 mm	44'7"
4 Maximum Loading Height	9160 mm	30'1"	9570 mm	31'5"	11 560 mm	37'11"
5 Minimum Loading Height	3570 mm	11'9"	3080 mm	10'1"	1310 mm	4'4"
6 Maximum Depth Cut for 2440 mm (8'0") Level Bottom	5650 mm	18'6"	5790 mm	19'0"	14 500 mm	47'7"
7 Maximum Vertical Wall Digging Depth	4940 mm	16'2"	5520 mm	18'1"	13 830 mm	45'4"
Bucket Digging Force (ISO)	179 kN	40,240 lbf	179 kN	40,240 lbf	60 kN	13,490 lbf
Stick Digging Force (ISO)	126 kN	28,325 lbf	114 kN	25,628 lbf	45 kN	10,120 lbf
Bucket Digging Force (ISO) – Auto Dig Boost	189 kN	42,480 lbf	189 kN	42,480 lbf	—	—
Stick Digging Force (ISO) – Auto Dig Boost	133 kN	29,899 lbf	120 kN	26,977 lbf	—	—
Bucket Type	HD		HD		DC	
Bucket Capacity	1.54 m <sup>3</sup>	2.01 yd <sup>3</sup>	1.54 m <sup>3</sup>	2.01 yd <sup>3</sup>	0.57 m <sup>3</sup>	0.75 yd <sup>3</sup>
Bucket Tip Radius	1658 mm	5'5"	1658 mm	5'5"	1090 mm	3'7"



# 330 Hydraulic Excavator Specifications

## Reach Boom Lift Capacities – Counterweight: 6700 kg (14,770 lb) – without Bucket, Heavy Lift: On

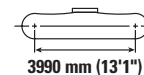
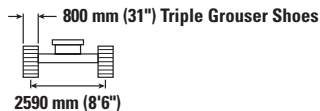
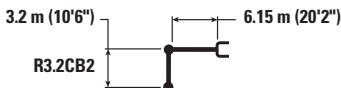

		1.5 m/5.0 ft		3.0 m/10.0 ft		4.5 m/15.0 ft		6.0 m/20.0 ft		7.5 m/25.0 ft		9.0 m/30.0 ft		m ft		
7.5 m 25.0 ft	kg lb													*5600 *12,350	*5600 *12,350	7.28 24.17
6.0 m 20.0 ft	kg lb								*7900 *16,700	6450 13,800				*5350 *11,750	*5350 *11,750	8.24 27.50
4.5 m 15.0 ft	kg lb							*9250 *20,050	8800 19,000	*8400 *18,300	6300 13,550			*5300 *11,650	4900 10,800	8.83 29.17
3.0 m 10.0 ft	kg lb					*14 250 *30,650	12 850 27,700	*10 800 *23,400	8450 18,200	*9150 *19,900	6150 13,200	*6500 4700		*5450 *11,950	4550 10,050	9.14 30.00
1.5 m 5.0 ft	kg lb					*17 000 *36,700	12 150 26,150	*12 300 *26,550	8100 17,450	9200 19,750	5950 12,800	7050 *13,650	4600 9,850	*5800 *12,700	4450 9,800	9.19 30.83
0 m 0 ft	kg lb					*18 300 *39,550	11 800 25,400	12 600 27,100	7850 16,950	9050 19,450	5800 12,500			*6350 *14,000	4550 10,000	8.99 30.00
-1.5 m -5.0 ft	kg lb	*6950 *15,550	*6950 *15,550	*10 950 *24,800	*10 950 *24,800	*18 250 *39,600	11 700 25,200	12 500 26,850	7750 16,700	8950 19,300	5750 12,350			*7350 *16,250	4850 10,700	8.52 28.33
-3.0 m -10.0 ft	kg lb	*12 500 *28,000	*12 500 *28,000	*17 650 *40,050	*17 650 *40,050	*17 150 *37,100	11 800 25,350	12 500 26,900	7750 16,750	9000 19,400	5800 12,500			8650 19,150	5550 12,300	7.73 25.83
-4.5 m -15.0 ft	kg lb			*19 900 *42,750	*19 900 *42,750	*14 600 *31,300	12 000 25,850	*10 800 *22,850	7950 17,150					*9500 *20,850	7150 16,000	6.51 21.67

## Reach Boom Lift Capacities – Counterweight: 6700 kg (14,770 lb) – without Bucket, Heavy Lift: On

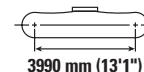
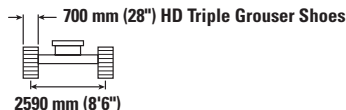
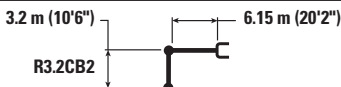

		1.5 m/5.0 ft		3.0 m/10.0 ft		4.5 m/15.0 ft		6.0 m/20.0 ft		7.5 m/25.0 ft		9.0 m/30.0 ft		m ft		
7.5 m 25.0 ft	kg lb													*5600 *12,350	*5600 *12,350	7.28 24.17
6.0 m 20.0 ft	kg lb									*7900 *16,700	6350 13,650			*5350 *11,750	*5350 *11,750	8.24 27.50
4.5 m 15.0 ft	kg lb							*9250 *20,050	8750 18,800	*8400 *18,300	6250 13,400			*5300 *11,650	4850 10,700	8.83 29.17
3.0 m 10.0 ft	kg lb					*14 250 *30,650	12 700 27,400	*10 800 *23,400	8350 18,000	*9150 *19,900	6050 13,050	*6500 4600		*5450 *11,950	4500 9,950	9.14 30.00
1.5 m 5.0 ft	kg lb					*17 000 *36,700	12 000 25,900	*12 300 *26,550	8000 17,250	9100 19,550	5900 12,650	6950 *13,650	4550 9,750	*5800 *12,700	4400 9,700	9.19 30.83
0 m 0 ft	kg lb					*18 300 *39,550	11 700 25,100	12 450 26,800	7750 16,750	8950 19,200	5750 12,350			*6350 *14,000	4500 9,850	8.99 30.00
-1.5 m -5.0 ft	kg lb	*6950 *15,550	*6950 *15,550	*10 950 *24,800	*10 950 *24,800	*18 250 *39,600	11 600 24,900	12 350 26,550	7650 16,500	8850 19,050	5650 12,200			*7350 *16,250	4800 10,600	8.52 28.33
-3.0 m -10.0 ft	kg lb	*12 500 *28,000	*12 500 *28,000	*17 650 *40,050	*17 650 *40,050	*17 150 *37,100	11 650 25,050	12 350 26,600	7700 16,550	8900 19,200	5700 12,350			8550 18,900	5500 12,200	7.73 25.83
-4.5 m -15.0 ft	kg lb			*19 900 *42,750	*19 900 *42,750	*14 600 *31,300	11 850 25,550	*10 800 *22,850	7850 16,950					*9500 *20,850	7050 15,850	6.51 21.67



ISO 10567:2007



\* Indicates that the load is limited by hydraulic lifting capacity rather than tipping load. The above loads are in compliance with hydraulic excavator lift capacity standard ISO 10567:2007. They do not exceed 87% of hydraulic lifting capacity or 75% of tipping load. Weight of all lifting accessories must be deducted from the above lifting capacities. Lifting capacities are based on the machine standing on a firm, uniform supporting surface. The use of a work tool attachment point to handle/lift objects, could affect the machine lift performance.

Lift capacity stays with ±5% for all available track shoes.

Always refer to the appropriate Operation and Maintenance Manual for specific product information.

# 330 Hydraulic Excavator Specifications

## Reach Boom Lift Capacities – Counterweight: 6700 kg (14,770 lb) – without Bucket, Heavy Lift: On

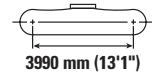
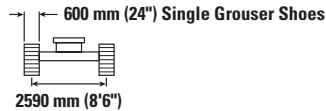
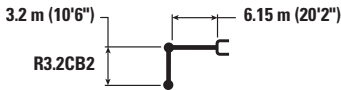

Reach Boom Configuration	1.5 m/5.0 ft		3.0 m/10.0 ft		4.5 m/15.0 ft		6.0 m/20.0 ft		7.5 m/25.0 ft		9.0 m/30.0 ft		m ft		
	kg	lb	kg	lb	kg	lb	kg	lb	kg	lb	kg	lb	kg	lb	
7.5 m 25.0 ft													*5600 *12,350	*5600 *12,350	7.28 24.17
6.0 m 20.0 ft									*7900 *16,700	6300 13,550			*5350 *11,750	*5350 *11,750	8.24 27.50
4.5 m 15.0 ft							*9250 *20,050	8650 18,650	*8400 *18,300	6200 13,300			*5300 *11,650	4800 10,600	8.83 29.17
3.0 m 10.0 ft					*14 250 *30,650	12 600 27,200	*10 800 *23,400	8300 17,850	*9150 *19,800	6000 12,950	*6500 4600		*5450 *11,950	4500 9,850	9.14 30.00
1.5 m 5.0 ft					*17 000 *36,700	11 900 25,650	*12 300 *26,550	7950 17,100	9000 19,350	5800 12,550	6900 *13,650	4500 9,650	*5800 *12,700	4350 9,600	9.19 30.83
0 m 0 ft					*18 300 *39,550	11 600 24,900	12 350 26,550	7700 16,600	8850 19,050	5700 12,250			*6350 *14,000	4450 9,800	8.99 30.00
-1.5 m -5.0 ft	kg lb	*6950 *15,550	*6950 *15,550	*10 950 *24,800	*10 950 *24,800	*18 250 *39,600	11 500 24,700	12 250 26,300	7600 16,350	8800 18,900	5600 12,100		7350 16,200	4750 10,500	8.52 28.33
-3.0 m -10.0 ft	kg lb	*12 500 *28,000	*12 500 *28,000	*17 650 *40,050	*17 650 *40,050	*17 150 *37,100	11 550 24,850	12 250 26,350	7600 16,400	8800 19,000	5650 12,200		8450 18,750	5450 12,050	7.73 25.83
-4.5 m -15.0 ft	kg lb			*19 900 *42,750	*19 900 *42,750	*14 600 *31,300	11 750 25,350	*10 800 *22,850	7800 16,800				*9500 *20,850	7000 15,700	6.51 21.67

## Reach Boom Lift Capacities – Counterweight: 6700 kg (14,770 lb) – without Bucket, Heavy Lift: On

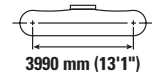
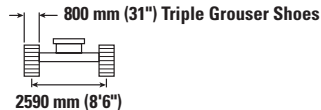
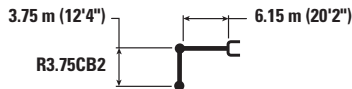

Reach Boom Configuration	1.5 m/5.0 ft		3.0 m/10.0 ft		4.5 m/15.0 ft		6.0 m/20.0 ft		7.5 m/25.0 ft		9.0 m/30.0 ft		m ft		
	kg	lb	kg	lb	kg	lb	kg	lb	kg	lb	kg	lb	kg	lb	
7.5 m 25.0 ft									*6000 *12,100	*6000 *12,100			*4800 *10,600	*4800 *10,600	7.90 25.83
6.0 m 20.0 ft									*7200 *15,650	6500 13,900			*4600 *10,100	*4600 *10,100	8.79 29.17
4.5 m 15.0 ft							*8400 *18,250	*8400 *18,250	*7750 *16,900	6350 13,600	*6050 *11,950	4750 10,150	*4550 *10,050	4450 9,850	9.34 30.83
3.0 m 10.0 ft					*12 850 *27,600	*12 850 *27,600	*10 000 *21,650	8500 18,250	*8600 *18,650	6100 13,150	7100 *15,200	4650 10,000	*4700 *10,300	4200 9,200	9.64 31.67
1.5 m 5.0 ft					*15 900 *34,300	12 150 26,200	*11 600 *25,100	8050 17,400	9150 19,700	5900 12,700	7000 15,000	4550 9,750	*4950 *10,900	4050 8,950	9.69 32.50
0 m 0 ft			*6750 *15,450	*6750 *15,450	*17 700 *38,250	11 700 25,150	12 550 26,950	7750 16,750	8950 19,250	5700 12,300	6900 14,800	4450 9,550	*5400 *11,900	4150 9,100	9.50 31.67
-1.5 m -5.0 ft	kg lb	*6650 *14,850	*6650 *14,850	*10 600 *24,000	*10 600 *24,000	*18 150 *39,350	11 500 24,700	12 350 26,550	7600 16,400	8850 19,050	5600 12,100	*6700 4400	*6200 *13,650	4400 9,650	9.06 30.00
-3.0 m -10.0 ft	kg lb	*11 000 *24,700	*11 000 *24,700	*15 850 *35,900	*15 850 *35,900	*17 500 *37,900	11 500 24,750	12 300 26,450	7600 16,350	8850 19,050	5600 12,100		*7550 *16,700	4950 10,900	8.32 27.50
-4.5 m -15.0 ft	kg lb	*16 400 *36,150	*16 400 *36,150	*21 850 *47,100	*21 850 *47,100	*15 600 *33,550	11 700 25,150	*11 650 *24,950	7700 16,600				*9050 *19,950	6050 13,550	7.20 23.33
-6.0 m -20.0 ft	kg lb					*11 350 *23,650	*11 350 *23,650						*8850 *22,000	*8850 *22,000	5.44 16.67



ISO 10567:2007



\* Indicates that the load is limited by hydraulic lifting capacity rather than tipping load. The above loads are in compliance with hydraulic excavator lift capacity standard ISO 10567:2007. They do not exceed 87% of hydraulic lifting capacity or 75% of tipping load. Weight of all lifting accessories must be deducted from the above lifting capacities. Lifting capacities are based on the machine standing on a firm, uniform supporting surface. The use of a work tool attachment point to handle/lift objects, could affect the machine lift performance.

Lift capacity stays with ±5% for all available track shoes.

Always refer to the appropriate Operation and Maintenance Manual for specific product information.

# 330 Hydraulic Excavator Specifications

## Reach Boom Lift Capacities – Counterweight: 6700 kg (14,770 lb) – without Bucket, Heavy Lift: On

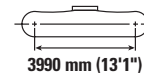
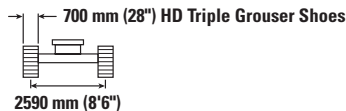
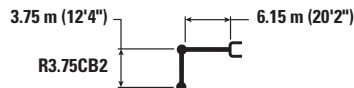

Reach m ft	kg lb	1.5 m/5.0 ft		3.0 m/10.0 ft		4.5 m/15.0 ft		6.0 m/20.0 ft		7.5 m/25.0 ft		9.0 m/30.0 ft		m ft				
7.5 m 25.0 ft										*6000 *12,100	*6000 *12,100			*4800 *10,600	*4800 *10,600	7.90 25.83		
6.0 m 20.0 ft										*7200 *15,650	6400 13,750			*4600 *10,100	*4600 *10,100	8.79 29.17		
4.5 m 15.0 ft								*8400 *18,250	*8400 *18,250	*7750 *16,900	6250 13,450	*6050 *11,950	4700 10,050	*4550 *10,050	4400 9,750	9.34 30.83		
3.0 m 10.0 ft						*12 850 *27,600	*12 850 *27,600	*10 000 *21,650	8400 18,050	*8600 *18,650	6050 13,000	7000 15,050	4600 9,850	*4700 *10,300	4150 9,100	9.64 31.67		
1.5 m 5.0 ft						*15 900 *34,300	12 050 25,950	*11 600 *25,100	8000 17,200	9050 19,450	5850 12,550	6900 14,800	4500 9,650	*4950 *10,900	4000 8,850	9.69 32.50		
0 m 0 ft						*6750 *15,450	*6750 *15,450	*17 700 *38,250	11 550 24,850	12 400 26,600	7700 16,550	8850 19,050	5650 12,150	6800 14,600	4400 9,450	*5400 *11,900	4100 8,950	9.50 31.67
-1.5 m -5.0 ft		*6650 *14,850	*6650 *14,850	*10 600 *24,000	*10 600 *24,000	*18 150 *39,350	11 350 24,450	12 200 26,200	7500 16,200	8750 18,800	5550 11,950	*6700 *14,600	4350 9,550	*6200 *13,650	4350 9,550	9.06 30.00		
-3.0 m -10.0 ft		*11 000 *24,700	*11 000 *24,700	*15 850 *35,900	*15 850 *35,900	*17 500 *37,900	11 350 24,450	12 150 26,150	7500 16,150	8750 18,800	5550 11,950			*7550 *16,700	4850 10,750	8.32 27.50		
-4.5 m -15.0 ft		*16 400 *36,300	*16 400 *36,300	*21 850 *47,100	*21 850 *47,100	*15 600 *33,550	11 550 24,850	*11 650 *24,950	7600 16,400					*9050 *19,950	6000 13,400	7.20 23.33		
-6.0 m -20.0 ft						*11 350 *23,650	*11 350 *23,650							*8850 *19,500	*8850 *19,500	5.44 16.67		



ISO 10567:2007



\* Indicates that the load is limited by hydraulic lifting capacity rather than tipping load. The above loads are in compliance with hydraulic excavator lift capacity standard ISO 10567:2007. They do not exceed 87% of hydraulic lifting capacity or 75% of tipping load. Weight of all lifting accessories must be deducted from the above lifting capacities. Lifting capacities are based on the machine standing on a firm, uniform supporting surface. The use of a work tool attachment point to handle/lift objects, could affect the machine lift performance.

Lift capacity stays with ±5% for all available track shoes.

Always refer to the appropriate Operation and Maintenance Manual for specific product information.

# 330 Hydraulic Excavator Specifications

## Reach Boom Lift Capacities – Counterweight: 6700 kg (14,770 lb) – without Bucket, Heavy Lift: On

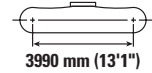
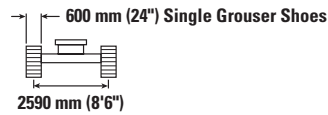
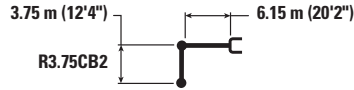

Reach	Unit	1.5 m/5.0 ft		3.0 m/10.0 ft		4.5 m/15.0 ft		6.0 m/20.0 ft		7.5 m/25.0 ft		9.0 m/30.0 ft		m ft		
		kg	lb	kg	lb	kg	lb	kg	lb	kg	lb	kg	lb	kg	lb	
7.5 m 25.0 ft	kg lb									*6000 *12,100	*6000 *12,100			*4800 *10,600	*4800 *10,600	7.90 25.83
6.0 m 20.0 ft	kg lb									*7200 *15,650	6350 13,650			*4600 *10,100	*4600 *10,100	8.79 29.17
4.5 m 15.0 ft	kg lb							*8400 *18,250	*8400 *18,250	*7750 *16,900	6200 13,350	*6050 *11,950	4650 9,950	*4550 *10,050	4350 9,650	9.34 30.83
3.0 m 10.0 ft	kg lb					*12 850 *27,600	12 750 27,500	*10 000 *21,650	8300 17,900	*8600 *18,650	6000 12,900	6950 14,950	4550 9,750	*4700 *10,300	4100 9,000	9.64 31.67
1.5 m 5.0 ft	kg lb					*15 900 *34,300	11 950 25,700	*11 600 *25,100	7900 17,050	8950 19,250	5800 12,450	6850 14,700	4450 9,550	*4950 *10,900	4000 8,750	9.69 32.50
0 m 0 ft	kg lb			*6750 *15,450	*6750 *15,450	*17 700 *38,250	11 450 24,650	12 250 26,350	7600 16,400	8750 18,850	5600 12,050	6750 14,500	4350 9,350	*5400 *11,900	4050 8,900	9.50 31.67
-1.5 m -5.0 ft	kg lb	*6650 *14,850	*6650 *14,850	*10 600 *24,000	*10 600 *24,000	*18 150 *39,350	11 250 24,200	12 100 25,950	7450 16,050	8650 18,650	5500 11,850	*6700 *13,650	4300 9,450	*6200 *13,650	4300 9,450	9.06 30.00
-3.0 m -10.0 ft	kg lb	*11 000 *24,700	*11 000 *24,700	*15 850 *35,900	*15 850 *35,900	*17 500 *37,900	11 250 24,250	12 050 25,900	7450 16,000	8650 18,650	5500 11,850			7500 16,600	4800 10,650	8.32 27.50
-4.5 m -15.0 ft	kg lb	*16 400 *36,400	*16 400 *36,400	*21 850 *47,100	*21 850 *47,100	*15 600 *33,550	11 450 24,650	*11 650 *24,950	7550 16,250					*9050 *19,950	5950 13,250	7.20 23.33
-6.0 m -20.0 ft	kg lb					*11 350 *23,650	*11 350 *23,650							*8850 *22,000	*8850 *22,000	5.44 16.67



ISO 10567:2007



\* Indicates that the load is limited by hydraulic lifting capacity rather than tipping load. The above loads are in compliance with hydraulic excavator lift capacity standard ISO 10567:2007. They do not exceed 87% of hydraulic lifting capacity or 75% of tipping load. Weight of all lifting accessories must be deducted from the above lifting capacities. Lifting capacities are based on the machine standing on a firm, uniform supporting surface. The use of a work tool attachment point to handle/lift objects, could affect the machine lift performance.

Lift capacity stays with ±5% for all available track shoes.

Always refer to the appropriate Operation and Maintenance Manual for specific product information.

# 330 Hydraulic Excavator Specifications

## Straight Boom Lift Capacities – Counterweight: 6700 kg (14,770 lb) – without Bucket, Heavy Lift: On

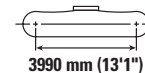
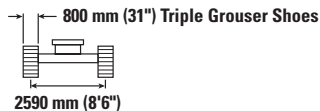
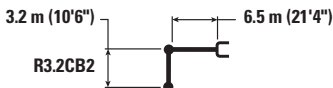

		3.0 m/10.0 ft		4.5 m/15.0 ft		6.0 m/20.0 ft		7.5 m/25.0 ft		9.0 m/30.0 ft		m ft		
10.5 m 35.0 ft	kg lb											*8500 *19,700	*8500 *19,700	4.34 13.00
9.0 m 30.0 ft	kg lb					*8200 *17,150	*8200 *17,150					*6450 *14,500	*6450 *14,500	6.56 20.91
7.5 m 25.0 ft	kg lb					*8400 *18,600	*8400 *18,600	*7500 *15,050	6350 13,550			*5750 *12,700	*5750 *12,700	7.90 25.58
6.0 m 20.0 ft	kg lb			*8050 *17,650	*8050 *17,650	*8850 *19,400	*8850 *19,200	*8750 *18,900	6300 13,550			*5400 *11,900	4850 10,800	8.78 28.58
4.5 m 15.0 ft	kg lb			*14,200 *29,050	13,300 28,650	*11,400 *24,500	8600 18,500	9450 20,350	6150 13,250	7100 *14,600	4650 9,950	*5300 *11,650	4350 9,650	9.34 30.50
3.0 m 10.0 ft	kg lb			*17,350 *37,350	12,400 26,700	*12,800 *27,650	8200 17,650	9250 19,850	5950 12,800	7000 15,100	4550 9,800	*5350 *11,750	4100 9,050	9.63 31.50
1.5 m 5.0 ft	kg lb			*12,250 *30,100	11,750 25,250	12,650 27,200	7850 16,900	9050 19,450	5750 12,450	6950 14,900	4500 9,650	*5550 *12,200	4050 8,900	9.68 31.75
0 m 0 ft	kg lb			*12,350 *29,200	11,500 24,700	12,400 26,650	7650 16,450	8900 19,150	5650 12,150	6850 14,800	4400 9,500	*5950 *13,050	4150 9,100	9.50 31.08
-1.5 m -5.0 ft	kg lb	*7050 *16,150	*7050 *16,150	*15,500 *33,700	11,450 24,650	*12,200 *26,450	7550 16,300	8850 19,050	5600 12,050	*6900 4450		*6600 *14,550	4400 9,700	9.05 29.58
-3.0 m -10.0 ft	kg lb			*12,500 *27,050	11,600 24,950	*10,150 *21,800	7600 16,400	*7650 *16,200	5650 12,200			*5750 *12,600	5000 11,050	8.32 27.16



ISO 10567:2007



\* Indicates that the load is limited by hydraulic lifting capacity rather than tipping load. The above loads are in compliance with hydraulic excavator lift capacity standard ISO 10567:2007. They do not exceed 87% of hydraulic lifting capacity or 75% of tipping load. Weight of all lifting accessories must be deducted from the above lifting capacities. Lifting capacities are based on the machine standing on a firm, uniform supporting surface. The use of a work tool attachment point to handle/lift objects, could affect the machine lift performance.

Lift capacity stays with ±5% for all available track shoes.

Always refer to the appropriate Operation and Maintenance Manual for specific product information.

# 330 Hydraulic Excavator Specifications

## Straight Boom Lift Capacities – Counterweight: 6700 kg (14,770 lb) – without Bucket, Heavy Lift: On

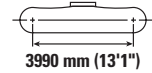
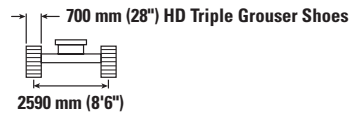
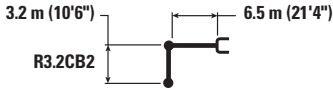

		3.0 m/10.0 ft		4.5 m/15.0 ft		6.0 m/20.0 ft		7.5 m/25.0 ft		9.0 m/30.0 ft		m ft		
10.5 m 35.0 ft	kg lb											*8500 *19,700	*8500 *19,700	4.34 13.00
9.0 m 30.0 ft	kg lb				*8200 *17,150	*8200 *17,150						*6450 *14,500	*6450 *14,500	6.56 20.91
7.5 m 25.0 ft	kg lb				*8400 *18,600	*8400 *18,600	*7500 *15,050	6300 13,400				*5750 *12,700	5750 *12,700	7.90 25.58
6.0 m 20.0 ft	kg lb			*8050 *17,650	*8050 *17,650	*8850 *19,400	8850 19,000	*8750 *18,900	6250 13,400			*5400 *11,900	4800 10,650	8.78 28.58
4.5 m 15.0 ft	kg lb			*14,200 *29,050	13,150 28,350	*11,400 *24,500	8500 18,300	9350 20,100	6100 13,100	7050 *14,600	4600 9,850	*5300 *11,650	4300 9,550	9.34 30.50
3.0 m 10.0 ft	kg lb			*17,350 *37,350	12,250 26,400	*12,800 *27,650	8100 17,450	9150 19,650	5900 12,700	6950 14,900	4500 9,700	*5350 *11,750	4050 8,950	9.63 31.50
1.5 m 5.0 ft	kg lb			*12,250 *30,100	11,600 25,000	12,500 26,850	7750 16,700	8950 19,200	5700 12,300	6850 14,750	4450 9,500	*5550 *12,200	4000 8,750	9.68 31.75
0 m 0 ft	kg lb			*12,350 *29,200	11,350 24,400	12,250 26,350	7550 16,250	8800 18,900	5600 12,000	6800 14,600	4350 9,400	*5950 *13,050	4100 8,950	9.50 31.08
-1.5 m -5.0 ft	kg lb	*7050 *16,150	*7050 *16,150	*15,500 *33,700	11,350 24,400	12,200 26,150	7500 16,100	8750 18,800	5550 11,900	6800 14,900	4400 9,400	*6600 *14,550	4350 9,600	9.05 29.58
-3.0 m -10.0 ft	kg lb			*12,500 *27,050	11,450 24,650	*10,150 *21,800	7550 16,250	*7650 *16,200	5600 12,050			*5750 *12,600	4950 10,900	8.32 27.16



ISO 10567:2007



\* Indicates that the load is limited by hydraulic lifting capacity rather than tipping load. The above loads are in compliance with hydraulic excavator lift capacity standard ISO 10567:2007. They do not exceed 87% of hydraulic lifting capacity or 75% of tipping load. Weight of all lifting accessories must be deducted from the above lifting capacities. Lifting capacities are based on the machine standing on a firm, uniform supporting surface. The use of a work tool attachment point to handle/lift objects, could affect the machine lift performance.

Lift capacity stays with ±5% for all available track shoes.

Always refer to the appropriate Operation and Maintenance Manual for specific product information.

# 330 Hydraulic Excavator Specifications

## Straight Boom Lift Capacities – Counterweight: 6700 kg (14,770 lb) – without Bucket, Heavy Lift: On

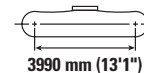
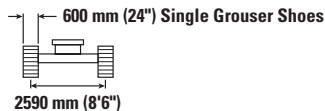
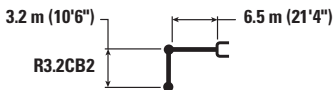

		3.0 m/10.0 ft		4.5 m/15.0 ft		6.0 m/20.0 ft		7.5 m/25.0 ft		9.0 m/30.0 ft		m ft		
10.5 m 35.0 ft	kg lb											*8500 *19,700	*8500 *19,700	4.34 13.00
9.0 m 30.0 ft	kg lb					*8200 *17,150	*8200 *17,150					*6450 *14,500	*6450 *14,500	6.56 20.91
7.5 m 25.0 ft	kg lb					*8400 *18,600	*8400 *18,600	*7500 *15,050	6250 13,300			*5750 *12,700	5700 *12,700	7.90 25.58
6.0 m 20.0 ft	kg lb			*8050 *17,650	*8050 *17,650	*8850 *19,400	8750 18,850	*8750 *18,900	6200 13,300			*5400 *11,900	4750 10,600	8.78 28.58
4.5 m 15.0 ft	kg lb			*14 200 *29,050	13 050 28,150	*11 400 *24,500	8450 18,150	9300 19,950	6050 13,000	6950 *14,600	4550 9,750	*5300 *11,650	4300 9,450	9.34 30.50
3.0 m 10.0 ft	kg lb			*17 350 *37,350	12 150 26,200	*12 800 27,500	8050 17,300	9050 19,500	5850 12,600	6900 14,800	4450 9,600	*5350 *11,750	4050 8,850	9.63 31.50
1.5 m 5.0 ft	kg lb			*12 250 *30,100	11 500 24,800	12 400 26,650	7700 16,550	8850 19,050	5650 12,200	6800 14,600	4400 9,450	*5550 *12,200	3950 8,700	9.68 31.75
0 m 0 ft	kg lb			*12 350 *29,200	11 250 24,200	12 150 26,100	7500 16,100	8700 18,750	5550 11,900	6750 14,500	4350 9,300	*5950 *13,050	4050 8,900	9.50 31.08
-1.5 m -5.0 ft	kg lb	*7050 *16,150	*7050 *16,150	*15 500 *33,700	11 250 24,150	12 050 25,950	7400 15,950	8650 18,650	5500 11,800	6750 14,500	4350 9,300	*6600 *14,550	4300 9,500	9.05 29.58
-3.0 m -10.0 ft	kg lb			*12 500 *27,050	11 400 24,450	*10 150 *21,800	7450 16,100	*7650 *16,200	5550 11,950			*5750 *12,600	4900 10,850	8.32 27.16



ISO 10567:2007



\* Indicates that the load is limited by hydraulic lifting capacity rather than tipping load. The above loads are in compliance with hydraulic excavator lift capacity standard ISO 10567:2007. They do not exceed 87% of hydraulic lifting capacity or 75% of tipping load. Weight of all lifting accessories must be deducted from the above lifting capacities. Lifting capacities are based on the machine standing on a firm, uniform supporting surface. The use of a work tool attachment point to handle/lift objects, could affect the machine lift performance.

Lift capacity stays with ±5% for all available track shoes.

Always refer to the appropriate Operation and Maintenance Manual for specific product information.

# 330 Hydraulic Excavator Specifications

## Straight Boom Lift Capacities – Counterweight: 6700 kg (14,770 lb) – without Bucket, Heavy Lift: On

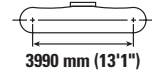
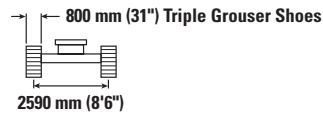
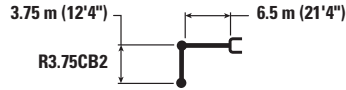

		3.0 m/10.0 ft		4.5 m/15.0 ft		6.0 m/20.0 ft		7.5 m/25.0 ft		9.0 m/30.0 ft		m ft		
10.5 m 35.0 ft	kg lb			<b>*17,700</b>	<b>*17,700</b>							*6600 <b>*15,050</b>	*6600 <b>*15,050</b>	5.41 <b>16.75</b>
9.0 m 30.0 ft	kg lb					*7300 <b>*16,000</b>	*7300 <b>*16,000</b>					*5400 <b>*12,000</b>	*5400 <b>*12,000</b>	7.31 <b>23.41</b>
7.5 m 25.0 ft	kg lb					*7000 <b>*15,500</b>	*7000 <b>*15,500</b>	*7000 <b>*15,100</b>	6400 <b>13,750</b>			*4850 <b>*10,750</b>	*4850 <b>*10,750</b>	8.53 <b>27.66</b>
6.0 m 20.0 ft	kg lb					*7150 <b>*15,800</b>	*7150 <b>*15,800</b>	*7450 <b>*16,300</b>	6350 <b>13,650</b>	*6100 <b>*12,050</b>	4700 <b>10,050</b>	*4600 <b>*10,150</b>	4400 <b>9,700</b>	9.35 <b>30.50</b>
4.5 m 15.0 ft	kg lb			*8900 <b>*19,000</b>	*8900 <b>*19,000</b>	*8800 <b>*19,100</b>	8650 <b>18,650</b>	*8500 <b>*18,450</b>	6150 <b>13,250</b>	7100 <b>15,300</b>	4650 <b>9,950</b>	*4550 <b>*9,950</b>	3950 <b>8,750</b>	9.88 <b>32.25</b>
3.0 m 10.0 ft	kg lb			*16 400 <b>*35,350</b>	12 550 <b>27,100</b>	*12 250 <b>*26,550</b>	8250 <b>17,700</b>	9250 <b>19,850</b>	5950 <b>12,800</b>	7000 <b>15,050</b>	4550 <b>9,750</b>	*4600 <b>*10,050</b>	3750 <b>8,250</b>	10.15 <b>33.25</b>
1.5 m 5.0 ft	kg lb			*17 600 <b>*38,850</b>	11 750 <b>25,350</b>	12 650 <b>27,150</b>	7850 <b>16,850</b>	9000 <b>19,350</b>	5750 <b>12,350</b>	6850 <b>14,800</b>	4400 <b>9,500</b>	*4750 <b>*10,400</b>	3700 <b>8,100</b>	10.20 <b>33.41</b>
0 m 0 ft	kg lb			*13 850 <b>*32,650</b>	11 350 <b>24,450</b>	12 350 <b>26,500</b>	7550 <b>16,250</b>	8800 <b>18,950</b>	5550 <b>12,000</b>	6800 <b>14,600</b>	4350 <b>9,300</b>	*5050 <b>*11,100</b>	3750 <b>8,250</b>	10.00 <b>32.83</b>
-1.5 m -5.0 ft	kg lb	*7150 <b>*16,200</b>	*7150 <b>*16,200</b>	*16 350 <b>*35,550</b>	11 250 <b>24,250</b>	12 200 <b>26,200</b>	7450 <b>16,000</b>	8750 <b>18,800</b>	5500 <b>11,800</b>	6750 <b>14,550</b>	4300 <b>9,250</b>	*5550 <b>*12,300</b>	4000 <b>8,750</b>	9.61 <b>31.41</b>
-3.0 m -10.0 ft	kg lb	*12 050 <b>*27,400</b>	*12 050 <b>*27,400</b>	*13 800 <b>*29,800</b>	11 350 <b>24,400</b>	*10 900 <b>*23,450</b>	7450 <b>16,050</b>	*8450 <b>*18,000</b>	5500 <b>11,850</b>			*5700 <b>*12,450</b>	4450 <b>9,800</b>	8.92 <b>29.08</b>
-4.5 m -15.0 ft	kg lb					*7950 <b>*16,800</b>	7600 <b>16,350</b>					*6200 <b>*14,300</b>	6050 <b>14,000</b>	7.11 <b>22.41</b>



ISO 10567:2007



\* Indicates that the load is limited by hydraulic lifting capacity rather than tipping load. The above loads are in compliance with hydraulic excavator lift capacity standard ISO 10567:2007. They do not exceed 87% of hydraulic lifting capacity or 75% of tipping load. Weight of all lifting accessories must be deducted from the above lifting capacities. Lifting capacities are based on the machine standing on a firm, uniform supporting surface. The use of a work tool attachment point to handle/lift objects, could affect the machine lift performance.

Lift capacity stays with ±5% for all available track shoes.

Always refer to the appropriate Operation and Maintenance Manual for specific product information.



# 330 Hydraulic Excavator Specifications

## Straight Boom Lift Capacities – Counterweight: 6700 kg (14,770 lb) – without Bucket, Heavy Lift: On

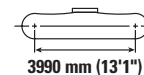
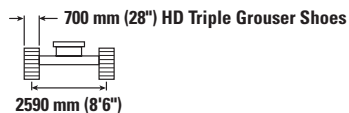
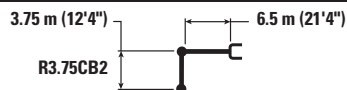

		3.0 m/10.0 ft		4.5 m/15.0 ft		6.0 m/20.0 ft		7.5 m/25.0 ft		9.0 m/30.0 ft		m ft		
10.5 m 35.0 ft	kg lb			<b>*17,700</b>	<b>*17,700</b>							*6600 <b>*15,050</b>	*6600 <b>*15,050</b>	5.41 <b>16.75</b>
9.0 m 30.0 ft	kg lb					*7300 <b>*16,000</b>	*7300 <b>*16,000</b>					*5400 <b>*12,000</b>	*5400 <b>*12,000</b>	7.31 <b>23.41</b>
7.5 m 25.0 ft	kg lb					*7000 <b>*15,500</b>	*7000 <b>*15,500</b>	*7000 <b>*15,100</b>	6350 <b>13,600</b>			*4850 <b>*10,750</b>	*4850 <b>*10,750</b>	8.53 <b>27.66</b>
6.0 m 20.0 ft	kg lb					*7150 <b>*15,800</b>	*7150 <b>*15,800</b>	*7450 <b>*16,300</b>	6300 <b>13,500</b>	*6100 <b>*12,050</b>	4650 <b>9,950</b>	*4600 <b>*10,150</b>	4350 <b>9,600</b>	9.35 <b>30.50</b>
4.5 m 15.0 ft	kg lb			*8900 <b>*19,000</b>	*8900 <b>*19,000</b>	*8800 <b>*19,100</b>	8550 <b>18,450</b>	*8500 <b>*18,450</b>	6100 <b>13,100</b>	7050 <b>15,100</b>	4600 <b>9,850</b>	*4550 <b>*9,950</b>	3900 <b>8,650</b>	9.88 <b>32.25</b>
3.0 m 10.0 ft	kg lb			*16 400 <b>*35,350</b>	12 450 <b>26,800</b>	*12 250 <b>*26,550</b>	8150 <b>17,550</b>	9150 <b>19,650</b>	5900 <b>12,650</b>	6900 <b>14,850</b>	4500 <b>9,600</b>	*4600 <b>*10,050</b>	3700 <b>8,150</b>	10.15 <b>33.25</b>
1.5 m 5.0 ft	kg lb			*17 600 <b>*38,850</b>	11 650 <b>25,050</b>	12 500 <b>26,850</b>	7750 <b>16,650</b>	8900 <b>19,150</b>	5650 <b>12,200</b>	6800 <b>14,600</b>	4350 <b>9,400</b>	*4750 <b>*10,400</b>	3650 <b>8,000</b>	10.20 <b>33.41</b>
0 m 0 ft	kg lb			*13 850 <b>*32,650</b>	11 250 <b>24,200</b>	12 200 <b>26,200</b>	7450 <b>16,100</b>	8700 <b>18,750</b>	5500 <b>11,850</b>	6700 <b>14,400</b>	4300 <b>9,200</b>	*5050 <b>*11,100</b>	3700 <b>8,150</b>	10.00 <b>32.83</b>
-1.5 m -5.0 ft	kg lb	*7150 <b>*16,200</b>	*7150 <b>*16,200</b>	*16 350 <b>*35,550</b>	11 150 <b>23,950</b>	12 050 <b>25,900</b>	7350 <b>15,800</b>	8600 <b>18,550</b>	5400 <b>11,650</b>	6650 <b>14,350</b>	4250 <b>9,150</b>	*5550 <b>*12,300</b>	3950 <b>8,650</b>	9.61 <b>31.41</b>
-3.0 m -10.0 ft	kg lb	*12 050 <b>*27,400</b>	*12 050 <b>*27,400</b>	*13 800 <b>*29,800</b>	11 200 <b>24,100</b>	*10 900 <b>*23,450</b>	7350 <b>15,850</b>	*8450 <b>*18,000</b>	5450 <b>11,700</b>			*5700 <b>*12,450</b>	4400 <b>9,700</b>	8.92 <b>29.08</b>
-4.5 m -15.0 ft	kg lb					*7950 <b>*16,800</b>	7500 <b>16,200</b>					*6200 <b>*14,300</b>	6000 <b>13,850</b>	7.11 <b>22.41</b>



ISO 10567:2007



\* Indicates that the load is limited by hydraulic lifting capacity rather than tipping load. The above loads are in compliance with hydraulic excavator lift capacity standard ISO 10567:2007. They do not exceed 87% of hydraulic lifting capacity or 75% of tipping load. Weight of all lifting accessories must be deducted from the above lifting capacities. Lifting capacities are based on the machine standing on a firm, uniform supporting surface. The use of a work tool attachment point to handle/lift objects, could affect the machine lift performance.

Lift capacity stays with ±5% for all available track shoes.

Always refer to the appropriate Operation and Maintenance Manual for specific product information.

# 330 Hydraulic Excavator Specifications

## Straight Boom Lift Capacities – Counterweight: 6700 kg (14,770 lb) – without Bucket, Heavy Lift: On

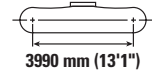
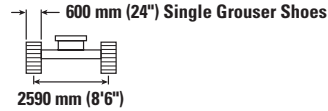
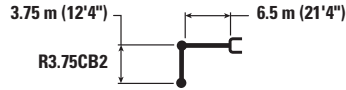

		3.0 m/10.0 ft		4.5 m/15.0 ft		6.0 m/20.0 ft		7.5 m/25.0 ft		9.0 m/30.0 ft		m ft		
10.5 m 35.0 ft	kg lb			<b>*17,700</b>	<b>*17,700</b>							*6600 <b>*15,050</b>	*6600 <b>*15,050</b>	5.41 <b>16.75</b>
9.0 m 30.0 ft	kg lb					*7300 <b>*16,000</b>	*7300 <b>*16,000</b>					*5400 <b>*12,000</b>	*5400 <b>*12,000</b>	7.31 <b>23.41</b>
7.5 m 25.0 ft	kg lb					*7000 <b>*15,500</b>	*7000 <b>*15,500</b>	*7000 <b>*15,100</b>	6300 <b>13,500</b>			*4850 <b>*10,750</b>	*4850 <b>*10,750</b>	8.53 <b>27.66</b>
6.0 m 20.0 ft	kg lb					*7150 <b>*15,800</b>	*7150 <b>*15,800</b>	*7450 <b>*16,300</b>	6250 <b>13,400</b>	*6100 <b>*12,050</b>	4600 <b>9,850</b>	*4600 <b>*10,150</b>	4300 <b>9,550</b>	9.35 <b>30.50</b>
4.5 m 15.0 ft	kg lb			*8900 <b>*19,000</b>	*8900 <b>*19,000</b>	*8800 <b>*19,100</b>	8500 <b>18,350</b>	*8500 <b>*18,450</b>	6050 <b>13,000</b>	6950 <b>14,950</b>	4550 <b>9,750</b>	*4550 <b>*9,950</b>	3900 <b>8,600</b>	9.88 <b>32.25</b>
3.0 m 10.0 ft	kg lb			*16 400 <b>*35,350</b>	12 350 <b>26,600</b>	*12 250 <b>*26,550</b>	8100 <b>17,400</b>	9050 <b>19,500</b>	5850 <b>12,550</b>	6850 <b>14,750</b>	4450 <b>9,550</b>	*4600 <b>*10,050</b>	3650 <b>8,100</b>	10.15 <b>33.25</b>
1.5 m 5.0 ft	kg lb			*17 600 <b>*38,850</b>	11 550 <b>24,850</b>	12 400 <b>26,650</b>	7700 <b>16,550</b>	8800 <b>18,950</b>	5600 <b>12,100</b>	6750 <b>14,450</b>	4350 <b>9,300</b>	*4750 <b>*10,400</b>	3600 <b>7,900</b>	10.20 <b>33.41</b>
0 m 0 ft	kg lb			*13 850 <b>*32,650</b>	11 150 <b>24,000</b>	12 100 <b>25,950</b>	7400 <b>15,950</b>	8650 <b>18,600</b>	5450 <b>11,750</b>	6650 <b>14,300</b>	4250 <b>9,100</b>	*5050 <b>*11,100</b>	3650 <b>8,050</b>	10.00 <b>32.83</b>
-1.5 m -5.0 ft	kg lb	*7150 <b>*16,200</b>	*7150 <b>*16,200</b>	*16 350 <b>*35,550</b>	11 050 <b>23,750</b>	11 950 <b>25,650</b>	7300 <b>15,700</b>	8550 <b>18,400</b>	5350 <b>11,550</b>	6600 <b>14,250</b>	4200 <b>9,100</b>	*5550 <b>*12,300</b>	3900 <b>8,550</b>	9.61 <b>31.41</b>
-3.0 m -10.0 ft	kg lb	*12 050 <b>*27,400</b>	*12 050 <b>*27,400</b>	*13 800 <b>*29,800</b>	11 150 <b>23,900</b>	*10 900 <b>*23,450</b>	7300 <b>15,700</b>	*8450 <b>*18,000</b>	5400 <b>11,600</b>			*5700 <b>*12,450</b>	4350 <b>9,600</b>	8.92 <b>29.08</b>
-4.5 m -15.0 ft	kg lb					*7950 <b>*16,800</b>	7450 <b>16,050</b>					*6200 <b>*14,300</b>	5950 <b>13,750</b>	7.11 <b>22.41</b>



ISO 10567:2007



\* Indicates that the load is limited by hydraulic lifting capacity rather than tipping load. The above loads are in compliance with hydraulic excavator lift capacity standard ISO 10567:2007. They do not exceed 87% of hydraulic lifting capacity or 75% of tipping load. Weight of all lifting accessories must be deducted from the above lifting capacities. Lifting capacities are based on the machine standing on a firm, uniform supporting surface. The use of a work tool attachment point to handle/lift objects, could affect the machine lift performance.

Lift capacity stays with ±5% for all available track shoes.

Always refer to the appropriate Operation and Maintenance Manual for specific product information.

# 330 Hydraulic Excavator Specifications

## SLR Boom Lift Capacities – Counterweight: 6700 kg (14,770 lb) – without Bucket

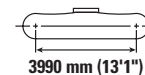
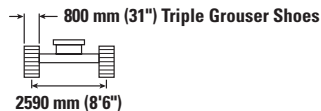
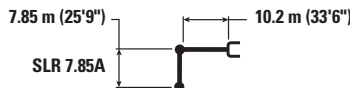

Reach m ft	kg lb	1.5 m/5.0 ft		3.0 m/10.0 ft		4.5 m/15.0 ft		6.0 m/20.0 ft		7.5 m/25.0 ft		9.0 m/30.0 ft		m ft		
		kg lb	kg lb	kg lb	kg lb	kg lb	kg lb	kg lb	kg lb	kg lb	kg lb	kg lb	kg lb	kg lb	kg lb	kg lb
12.0 m 40.0 ft														*1350 *2,950	*1350 *2,950	14.03 45.83
10.5 m 35.0 ft														*1300 *2,800	*1300 *2,800	15.01 49.17
9.0 m 30.0 ft														*1250 *2,750	*1250 *2,750	15.78 51.67
7.5 m 25.0 ft														*1250 *2,750	*1250 *2,750	16.37 54.17
6.0 m 20.0 ft														*1250 *2,750	*1250 *2,750	16.81 55.00
4.5 m 15.0 ft														*1300 *2,800	*1300 *2,800	17.11 56.67
3.0 m 10.0 ft				*4050	*4050							*4150 *9,000	*4150 *9,000	*1350 *2,900	*1350 *2,900	17.27 56.67
1.5 m 5.0 ft				*1550 *3,550	*1550 *3,550	*5200 *12,150	*5200 *12,150	*7400 *15,950	7350 15,850	*5750 *12,350	5450 11,800	*4750 *10,300	4250 9,200	*1400 *3,000	*1400 *3,000	17.30 56.67
0 m 0 ft				*1650 *3,750	*1650 *3,750	*3600 *8,250	*3600 *8,250	*8250 *18,500	6600 14,250	*6550 *14,100	5000 10,750	*5350 *11,550	3950 8,500	*1450 *3,150	1450 3,150	17.19 56.67
-1.5 m -5.0 ft		*1650 *3,600	*1650 *3,600	*2150 *4,800	*2150 *4,800	*3550 *8,000	*3550 *8,000	*6500 *14,900	6150 13,250	*7200 *15,500	4650 10,000	*5800 *12,550	3700 7,950	*1550 *3,400	1450 3,150	16.96 55.83
-3.0 m -10.0 ft		*2250 *4,950	*2250 *4,950	*2750 *6,100	*2750 *6,100	*3900 *8,750	*3900 *8,750	*6250 *14,250	5900 12,650	*7600 *16,300	4400 9,500	*5900 *12,700	3500 7,500	*1650 *3,650	1500 3,250	16.58 55.00
-4.5 m -15.0 ft		*2850 *6,300	*2850 *6,300	*3350 *7,500	*3350 *7,500	*4450 *10,050	*4450 *10,050	*6600 *14,950	5750 12,400	*7450 *16,000	4300 9,200	*5800 *12,450	3400 7,250	*1850 *4,050	1550 3,350	16.05 52.50
-6.0 m -20.0 ft		*3450 *7,750	*3450 *7,750	*4050 *9,050	*4050 *9,050	*5150 *11,650	*5150 *11,650	*7250 *16,500	5750 12,400	*7400 *15,900	4250 9,100	*5700 *12,300	3350 7,150	*2100 *4,600	1650 3,600	15.36 50.83
-7.5 m -25.0 ft		*4150 *9,250	*4150 *9,250	*4800 *10,800	*4800 *10,800	*6050 *13,600	*6050 *13,600	*8250 *18,850	5800 12,550	*7400 *15,950	4250 9,150	*5700 *12,300	3350 7,150	*2400 *5,350	1800 4,000	14.47 47.50
-9.0 m -30.0 ft		*4900 *10,900	*4900 *10,900	*5650 *12,750	*5650 *12,750	*7050 *16,000	*7050 *16,000	*9550 *20,650	5950 12,850	*7500 *16,150	4350 9,350	*5800 *12,450	3400 7,300	*2950 *6,600	2050 4,600	13.36 44.17
-10.5 m -35.0 ft		*5700 *12,750	*5700 *12,750	*6650 *15,000	*6650 *15,000	*8350 *19,050	*8350 *19,050	*8850 *18,950	6150 13,350	*7150 *15,350	4500 9,700	*5900 *12,700	3500 7,600	*3900 *8,950	2450 5,550	11.96 39.17
-12.0 m -40.0 ft				*7850 *17,700	*7850 *17,700	*9800 *20,750	*9800 *20,750	*7700 *16,300	6500 14,050	*6250 *13,200	4750 10,250	*5100 *10,700	3700 8,100	*4350 *9,600	3200 7,400	10.14 32.50



ISO 10567:2007



\* Indicates that the load is limited by hydraulic lifting capacity rather than tipping load. The above loads are in compliance with hydraulic excavator lift capacity standard ISO 10567:2007. They do not exceed 87% of hydraulic lifting capacity or 75% of tipping load. Weight of all lifting accessories must be deducted from the above lifting capacities. Lifting capacities are based on the machine standing on a firm, uniform supporting surface. The use of a work tool attachment point to handle/lift objects, could affect the machine lift performance.

Lift capacity stays with ±5% for all available track shoes.



Always refer to the appropriate Operation and Maintenance Manual for specific product information.

(continued on next page)

# 330 Hydraulic Excavator Specifications

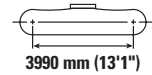
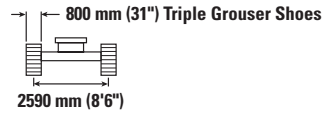
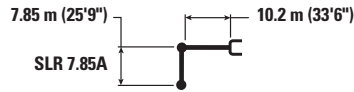
## SLR Boom Lift Capacities – Counterweight: 6700 kg (14,770 lb) – without Bucket (continued)



	10.5 m/35.0 ft		12.0 m/40.0 ft		13.5 m/45.0 ft		15.0 m/50.0 ft		16.5 m/55.0 ft						
	kg	lb	kg	lb	kg	lb	kg	lb	kg	lb	kg	lb	m	ft	
12.0 m 40.0 ft													*1350	*1350	14.03
	kg												*2,950	*2,950	45.83
	lb														
10.5 m 35.0 ft								*1300	*1300				*1300	*1300	15.01
	kg							*2100	*2100				*1250	*1250	15.78
	lb							*3,950	*3,950				*2,750	*2,750	51.67
9.0 m 30.0 ft															
	kg														
	lb														
7.5 m 25.0 ft															
	kg					*2650	*2650	*2550	2250				*1250	*1250	16.37
	lb					*5,800	*5,800	*5,200	4,700				*2,750	*2,750	54.17
6.0 m 20.0 ft															
	kg					*2800	2650	*2750	2150	*1700	*1700		*1250	*1250	16.81
	lb					*6,100	5,700	*6,050	4,600	*2,850	*2,850		*2,750	*2,750	55.00
4.5 m 15.0 ft															
	kg														
	lb														
3.0 m 10.0 ft															
	kg	*3700	3650	*3400	2950	*3200	2450	*3050	2000	*2350	1650	*1350	*1350	17.27	
	lb	*8,050	7,900	*7,400	6,350	*6,950	5,200	*6,650	4,300	*4,500	3,550	*2,900	*2,900	56.67	
1.5 m 5.0 ft															
	kg	*4150	3400	*3750	2800	*3450	2300	3150	1950	*2550	1600	*1400	*1400	17.30	
	lb	*9,000	7,350	*8,100	6,000	*7,450	4,950	6,750	4,100	*4,800	3,400	*3,000	*3,000	56.67	
0 m 0 ft															
	kg	*4550	3200	*4050	2650	3600	2200	3050	1850	*2550	1550	*1450	1450	17.19	
	lb	*9,850	6,850	*8,750	5,650	7,700	4,700	6,550	3,950	*4,750	3,300	*3,150	3,150	56.67	
-1.5 m -5.0 ft															
	kg	*4900	3000	4100	2500	3500	2100	3000	1750	*2400	1500	*1550	1450	16.96	
	lb	*10,650	6,450	8,850	5,350	7,500	4,500	6,400	3,800	*4,150	3,200	*3,400	3,150	55.83	
-3.0 m -10.0 ft															
	kg	4800	2850	4000	2400	3400	2000	2950	1700	*1850	1500	*1650	1500	16.58	
	lb	10,300	6,150	8,600	5,100	7,300	4,300	6,300	3,650			*3,650	3,250	55.00	
-4.5 m -15.0 ft															
	kg	4700	2750	3900	2300	3350	1950	2900	1700			*1850	1550	16.05	
	lb	10,100	5,950	8,450	4,950	7,200	4,200	6,250	3,600			*4,050	3,350	52.50	
-6.0 m -20.0 ft															
	kg	4650	2700	3900	2250	3350	1950	2900	1700			*2100	1650	15.36	
	lb	10,000	5,850	8,350	4,900	7,150	4,150	*4,950	3,650			*4,600	3,600	50.83	
-7.5 m -25.0 ft															
	kg	4650	2700	3900	2300	3350	1950						*2400	1800	14.47
	lb	10,000	5,850	8,400	4,900	7,200	4,200						*5,350	4,000	47.50
-9.0 m -30.0 ft															
	kg	4700	2750	3950	2350								*2950	2050	13.36
	lb	10,150	5,950	8,500	5,050								*6,600	4,600	44.17
-10.5 m -35.0 ft															
	kg	4800	2900										*3900	2450	11.96
	lb	10,400	6,250										*8,950	5,550	39.17
-12.0 m -40.0 ft															
	kg												*4350	3200	10.14
	lb												*9,600	7,400	32.50



ISO 10567:2007



\* Indicates that the load is limited by hydraulic lifting capacity rather than tipping load. The above loads are in compliance with hydraulic excavator lift capacity standard ISO 10567:2007. They do not exceed 87% of hydraulic lifting capacity or 75% of tipping load. Weight of all lifting accessories must be deducted from the above lifting capacities. Lifting capacities are based on the machine standing on a firm, uniform supporting surface. The use of a work tool attachment point to handle/lift objects, could affect the machine lift performance.

Lift capacity stays with ±5% for all available track shoes.

Always refer to the appropriate Operation and Maintenance Manual for specific product information.

# 330 Hydraulic Excavator Specifications

## Bucket Specifications and Compatibility

	Linkage	Width		Capacity		Weight		Fill	Reach Boom		Straight Boom		SLR Boom
		mm	in	m <sup>3</sup>	yd <sup>3</sup>	kg	lb		%	R3.2 (10'6")	R3.75 (12'4")	R3.2 (10'6")	R3.75 (12'4")
<b>Pin-On (No Quick Coupler)</b>													
General Duty Capacity	CB	600	24	0.63	0.83	724	1,597	100	●	●	●	●	
	CB	750	30	0.86	1.13	811	1,788	100	●	●	●	●	
	CB	900	36	1.09	1.43	908	2,002	100	●	●	●	●	
	CB	1050	42	1.34	1.75	980	2,161	100	●	●	●	●	
	CB	1200	48	1.58	2.07	1072	2,363	100	●	⊙	⊙	⊙	
	CB	1350	54	1.83	2.40	1166	2,570	100	⊙	⊖	⊖	⊖	
General Duty Capacity – Wide Tip	CB	600	24	0.63	0.83	749	1,652	100	●	●	●	●	
	CB	750	30	0.86	1.13	845	1,863	100	●	●	●	●	
	CB	900	36	1.09	1.43	942	2,077	100	●	●	●	●	
	CB	1050	42	1.34	1.75	1022	2,253	100	●	●	●	●	
	CB	1200	48	1.58	2.07	1123	2,475	100	●	⊙	⊙	⊙	
	CB	1350	54	1.83	2.40	1224	2,698	100	⊙	⊖	⊖	⊖	
Heavy Duty	CB	600	24	0.52	0.68	733	1,616	100	●	●	●	●	
	CB	750	30	0.71	0.93	851	1,876	100	●	●	●	●	
	CB	900	36	0.91	1.19	945	2,084	100	●	●	●	●	
	CB	1050	42	1.12	1.46	1041	2,295	100	●	●	●	●	
	CB	1200	48	1.33	1.74	1112	2,452	100	●	●	●	●	
	CB	1350	54	1.54	2.02	1212	2,672	100	●	⊙	⊙	⊙	
	CB	1500	60	1.76	2.30	1306	2,879	100	⊙	⊖	⊖	⊖	
	CB	1650	66	1.97	2.58	1383	3,048	100	⊖	⊖	⊖	⊖	
Heavy Duty Power	CB	1050	42	1.12	1.47	1070	2,360	100	●	●	●	●	
	CB	1200	48	1.33	1.73	1148	2,532	100	●	●	●	●	
	CB	1350	54	1.53	2.01	1253	2,762	100	●	⊙	⊙	⊙	
Severe Duty	CB	600	24	0.52	0.68	755	1,665	90	●	●	●	●	
	CB	750	30	0.71	0.93	915	2,017	90	●	●	●	●	
	CB	900	36	0.91	1.19	1000	2,204	90	●	●	●	●	
	CB	1050	42	1.12	1.46	1099	2,424	90	●	●	●	●	
	CB	1200	48	1.33	1.74	1177	2,596	90	●	●	●	●	
Ditch Cleaning	A	1150	45	0.60	0.78	292	644	100					○
	A	1200	48	0.57	0.74	388	855	100					○
	A	1500	60	0.74	0.97	455	1,003	100					◇
General Duty	A	900	36	0.53	0.69	394	869	100					○
	Maximum load with pin-on (payload + bucket)								kg	4605	4135	4037	3990
								lb	10,152	9,116	8,900	8,796	2,502

### Maximum Material Density:

- 2100 kg/m<sup>3</sup> (3,500 lb/yd<sup>3</sup>)
- ⊙ 1800 kg/m<sup>3</sup> (3,000 lb/yd<sup>3</sup>)
- ⊖ 1500 kg/m<sup>3</sup> (2,500 lb/yd<sup>3</sup>)
- 1200 kg/m<sup>3</sup> (2,000 lb/yd<sup>3</sup>)
- ◇ 900 kg/m<sup>3</sup> (1,500 lb/yd<sup>3</sup>)

The above loads are in compliance with hydraulic excavator standard EN474-5:2006+A3:2013, they do not exceed 87% of hydraulic lifting capacity or 75% of tipping capacity with front linkage fully extended at ground line with bucket curled.

Capacity based on ISO 7451:2007

Bucket weight with General Duty tips.

Caterpillar recommends using appropriate work tools to maximize the value customers receive from our products. Use of work tools, including buckets, which are outside of Caterpillar's recommendations or specifications for weight, dimensions, flows, pressures, etc. may result in less-than-optimal performance, including but not limited to reductions in production, stability, reliability, and component durability. Improper use of a work tool resulting in sweeping, prying, twisting and/or catching of heavy loads will reduce the life of the boom and stick.

(continued on next page)

# 330 Hydraulic Excavator Specifications

## Bucket Specifications and Compatibility (continued)

	Linkage	Width		Capacity		Weight		Fill	Reach Boom		Straight Boom		SLR Boom
		mm	in	m <sup>3</sup>	yd <sup>3</sup>	kg	lb		%	R3.2 (10'6")	R3.75 (12'4")	R3.2 (10'6")	R3.75 (12'4")
<b>With Pin Grabber Quick Coupler</b>													
General Duty Capacity	CB	600	24	0.63	0.83	724	1,597	100	●	●	●	●	
	CB	750	30	0.86	1.13	811	1,788	100	●	●	●	●	
	CB	900	36	1.09	1.43	908	2,002	100	●	●	●	●	
	CB	1050	42	1.34	1.75	980	2,161	100	●	●	⊙	⊙	
	CB	1200	48	1.58	2.07	1072	2,363	100	●	⊙	⊖	⊖	
	CB	1350	54	1.83	2.40	1166	2,570	100	⊙	⊖	○	○	
General Duty Capacity – Wide Tip	CB	600	24	0.63	0.83	749	1,652	100	●	●	●	●	
	CB	750	30	0.86	1.13	845	1,863	100	●	●	●	●	
	CB	900	36	1.09	1.43	942	2,077	100	●	●	●	●	
	CB	1050	42	1.34	1.75	1022	2,253	100	●	●	⊙	⊙	
	CB	1200	48	1.58	2.07	1123	2,475	100	●	⊙	⊖	⊖	
	CB	1350	54	1.83	2.40	1224	2,698	100	⊙	⊖	○	○	
Heavy Duty	CB	600	24	0.52	0.68	733	1,616	100	●	●	●	●	
	CB	750	30	0.71	0.93	851	1,876	100	●	●	●	●	
	CB	900	36	0.91	1.19	945	2,084	100	●	●	●	●	
	CB	1050	42	1.12	1.46	1041	2,295	100	●	●	●	●	
	CB	1200	48	1.33	1.74	1112	2,452	100	●	●	⊙	⊙	
	CB	1350	54	1.54	2.02	1212	2,672	100	●	⊙	⊖	⊖	
	CB	1500	60	1.76	2.30	1306	2,879	100	⊙	⊖	○	○	
	CB	1650	66	1.97	2.58	1383	3,048	100	⊖	○	◇	◇	
Heavy Duty Power	CB	1050	42	1.12	1.47	1070	2,360	100	●	●	●	●	
	CB	1200	48	1.33	1.73	1148	2,532	100	●	●	⊙	⊙	
	CB	1350	54	1.53	2.01	1253	2,762	100	●	⊙	⊖	⊖	
Heavy Duty – Pin Grabber Performance	CB	750	30	0.70	0.91	879	1,938	100	●	●	●	●	
	CB	1050	42	1.08	1.42	1110	2,448	100	●	●	●	●	
	CB	1200	48	1.28	1.68	1191	2,626	100	●	●	⊙	⊙	
	CB	1350	54	1.49	1.94	1299	2,864	100	●	⊙	⊖	⊖	
	CB	1500	60	1.69	2.21	1406	3,099	100	⊙	⊖	○	○	
Severe Duty	CB	600	24	0.52	0.68	755	1,665	90	●	●	●	●	
	CB	750	30	0.71	0.93	915	2,017	90	●	●	●	●	
	CB	900	36	0.91	1.19	1000	2,204	90	●	●	●	●	
	CB	1050	42	1.12	1.46	1099	2,424	90	●	●	●	●	
	CB	1200	48	1.33	1.74	1177	2,596	90	●	●	⊙	⊙	
Severe Duty – Pin Grabber Performance	CB	600	24	0.51	0.66	832	1,835	90	●	●	●	●	
	CB	900	36	0.88	1.16	1062	2,341	90	●	●	●	●	
	CB	1050	42	1.08	1.42	1170	2,580	90	●	●	●	●	
	CB	1200	48	1.28	1.68	1257	2,772	90	●	●	⊙	⊙	
Ditch Cleaning	312, A	1150	45	0.60	0.78	292	644	100					X
	312, A	1200	48	0.57	0.74	388	855	100					X
	312, A	1500	60	0.74	0.97	455	1,003	100					X
General Duty	312, A	900						kg	4079	3609	3511	3464	609
			lb	8,992	7,956	7,740	7,636	1,342					

**Maximum Material Density:**

- 2100 kg/m<sup>3</sup> (3,500 lb/yd<sup>3</sup>)
- ⊙ 1800 kg/m<sup>3</sup> (3,000 lb/yd<sup>3</sup>)
- ⊖ 1500 kg/m<sup>3</sup> (2,500 lb/yd<sup>3</sup>)
- 1200 kg/m<sup>3</sup> (2,000 lb/yd<sup>3</sup>)
- ◇ 900 kg/m<sup>3</sup> (1,500 lb/yd<sup>3</sup>)
- X Not Recommended

The above loads are in compliance with hydraulic excavator standard EN474-5:2006+A3:2013, they do not exceed 87% of hydraulic lifting capacity or 75% of tipping capacity with front linkage fully extended at ground line with bucket curled.

Capacity based on ISO 7451:2007.

Bucket weight with General Duty tips.

Caterpillar recommends using appropriate work tools to maximize the value customers receive from our products. Use of work tools, including buckets, which are outside of Caterpillar's recommendations or specifications for weight, dimensions, flows, pressures, etc. may result in less-than-optimal performance, including but not limited to reductions in production, stability, reliability, and component durability. Improper use of a work tool resulting in sweeping, prying, twisting and/or catching of heavy loads will reduce the life of the boom and stick.

(continued on next page)

# 330 Hydraulic Excavator Specifications

## Bucket Specifications and Compatibility (continued)

		Linkage	Width		Capacity		Weight		Fill	Reach Boom		Straight Boom	
			mm	in	m <sup>3</sup>	yd <sup>3</sup>	kg	lb		%	R3.2 (10'6")	R3.75 (12'4")	R3.2 (10'6")
<b>PIN-ON TRS23 S70</b>													
General Duty	Grading	CB	2000	79	1.60	2.09	1004	2,213	100	⊖	○	○	○
	Digging	CB	1500	59	1.50	1.96	1289	2,842	100	⊖	○	○	○
	Digging	CB	1580	62	1.60	2.09	1339	2,952	100	⊖	○	○	◇
Maximum load with pin-on (payload + bucket)									kg	3738	3268	3170	3123
									lb	8,241	7,205	6,989	6,885
<b>WITH S70 TRS23 S70</b>													
General Duty	Grading	CB	2000	79	1.60	2.09	1004	2,213	100	⊖	○	○	○
	Digging	CB	1500	59	1.50	1.96	1289	2,842	100	⊖	○	◇	◇
	Digging	CB	1580	62	1.60	2.09	1339	2,952	100	○	◇	◇	◇
Maximum load with pin-on (payload + bucket)									kg	3514	3044	2946	2899
									lb	7,747	6,711	6,495	6,391
<b>PIN-ON TRS23 S80</b>													
General Duty	Grading	CB	2000	79	1.60	2.09	1004	2,213	100	⊖	○	○	○
	Digging	CB	1500	59	1.50	1.96	1289	2,842	100	⊖	○	○	◇
	Digging	CB	1580	62	1.60	2.09	1339	2,952	100	○	◇	◇	◇
Maximum load with pin-on (payload + bucket)									kg	3655	3185	3087	3040
									lb	8,058	7,022	6,806	6,702
<b>WITH S80 TRS23 S80</b>													
General Duty	Grading	CB	2000	79	1.60	2.09	1004	2,213	100	○	◇	◇	◇
	Digging	CB	1500	59	1.50	1.96	1289	2,842	100	○	◇	◇	X
	Digging	CB	1580	62	1.60	2.09	1339	2,952	100	○	◇	X	X
Maximum load with pin-on (payload + bucket)									kg	3237	2767	2669	2622
									lb	7,136	6,100	5,884	5,781

### Maximum Material Density:

- 2100 kg/m<sup>3</sup> (3,500 lb/yd<sup>3</sup>)
- ◎ 1800 kg/m<sup>3</sup> (3,000 lb/yd<sup>3</sup>)
- ⊖ 1500 kg/m<sup>3</sup> (2,500 lb/yd<sup>3</sup>)
- 1200 kg/m<sup>3</sup> (2,000 lb/yd<sup>3</sup>)
- ◇ 900 kg/m<sup>3</sup> (1,500 lb/yd<sup>3</sup>)
- X Not Recommended

The above loads are in compliance with hydraulic excavator standard EN474-5:2006+A3:2013, they do not exceed 87% of hydraulic lifting capacity or 75% of tipping capacity with front linkage fully extended at ground line with bucket curled.

Capacity based on ISO 7451:2007.

Bucket weight with General Duty tips.

Caterpillar recommends using appropriate work tools to maximize the value customers receive from our products. Use of work tools, including buckets, which are outside of Caterpillar's recommendations or specifications for weight, dimensions, flows, pressures, etc. may result in less-than-optimal performance, including but not limited to reductions in production, stability, reliability, and component durability. Improper use of a work tool resulting in sweeping, prying, twisting and/or catching of heavy loads will reduce the life of the boom and stick.

# 330 Hydraulic Excavator Specifications

## Attachments Offering Guide

Not all Attachments are available in all regions. Consult your Cat dealer for configurations available in your region.

Match

\* Working range front only

No Match

### PIN-ON ATTACHMENTS

Boom Type	Stick Length	Reach		Straight	
		R3.2 (10'6")	R3.75 (12'4")	R3.2 (10'6")	R3.75 (12'4")
Hydraulic Hammers	H120 S	✓	✓	✓	✓
	H130 GC	✓	✓		
	H130 GC S	✓	✓	✓	✓
	H130 S	✓	✓	✓	✓
	H140 GC	✓	✓		
	H140 GC S	✓	✓	✓	✓
	H140 S	✓	✓	✓	✓
	H160 GC	✓	✓		
	H160 GC S	✓	✓	✓	✓
	H160 S	✓	✓	✓	✓*
Multi-Processors	MP324 Concrete Cutter Jaw	✓	✓	✓	✓
	MP324 Demolition Jaw	✓	✓	✓	✓
	MP324 Pulverizer Jaw	✓	✓	✓	✓
	MP324 Shear Jaw	✓	✓	✓	✓
	MP324 Tank Shear Jaw	✓	✓	✓	✓
	MP324 Universal Jaw	✓	✓	✓	✓
	MP332 Concrete Cutter Jaw	✓	✓	✓	
	MP332 Demolition Jaw	✓	✓*	✓*	
	MP332 Pulverizer Jaw	✓	✓*	✓*	
	MP332 Shear Jaw	✓	✓	✓	
	MP332 Tank Shear Jaw	✓*			
	MP332 Universal Jaw	✓	✓*	✓*	
Demolition and Sorting Grapples	G324	✓	✓	✓	✓
	G324 WH-1500	✓	✓	✓	✓
	G324 WH-1800	✓	✓	✓	✓*
	G324 WH-2000	✓	✓		
	G332	✓	✓	✓	✓*
Mobile Scrap and Demolition Shears	S3025 Flat Top	✓	✓	✓	✓
	S3035 Flat Top	✓	✓		
Pulverizers	P224 Secondary Pulverizer	✓	✓	✓	✓
	P324 Primary Pulverizer	✓	✓	✓	✓
	P332 Primary Pulverizer	✓	✓*	✓*	
Mulchers	HM5515	✓	✓	✓	✓
	HM6015	✓	✓	✓	✓
Compactors (Vibratory Plate)	CVP110	✓	✓	✓	✓
Rotary Cutters	RC20	✓	✓	✓	✓
	RC30	✓	✓	✓	✓

(continued on next page)



# 330 Hydraulic Excavator Specifications

## Attachments Offering Guide (continued)

Not all Attachments are available in all regions. Consult your Cat dealer for configurations available in your region.

<input checked="" type="checkbox"/> Match	<input type="checkbox"/> * Working range front only	<input type="checkbox"/> † Allowed usage on machine less than 50%	<input type="checkbox"/> No Match	<input checked="" type="checkbox"/> 1800 kg/m <sup>3</sup> (3,000 lb/yd <sup>3</sup> )	<input type="checkbox"/> 1200 kg/m <sup>3</sup> (2,000 lb/yd <sup>3</sup> )	<input type="checkbox"/> ◇ 600 kg/m <sup>3</sup> (1,000 lb/yd <sup>3</sup> )
-------------------------------------------	-----------------------------------------------------	-------------------------------------------------------------------	-----------------------------------	-------------------------------------------------------------------------------------------	--------------------------------------------------------------------------------	---------------------------------------------------------------------------------

### PIN-ON ATTACHMENTS (continued)

Boom Type	Stick Length		Reach		Straight	
			R3.2 (10'6")	R3.75 (12'4")	R3.2 (10'6")	R3.75 (12'4")
Orange Peel Grapples		GSH425-750	●	●	●	●
		GSH425-950	●	●	●	●
		GSH425-1150	●	●	●	○
		GSH440-950	●	●	●	○
		GSH440-1150	●	○	○	○
		GSH440-1550	○			◇
		GSH525-750	●	●	●	●
		GSH525-950	●	●	●	○
		GSH525-1150	●	○	○	○
Clamshell Grapples		CTV15-1900	○			
		CTV20-1500	○	○	○	

### CAT PIN GRABBER COUPLER ATTACHMENTS

Boom Type	Stick Length		Reach		Straight	
			R3.2 (10'6")	R3.75 (12'4")	R3.2 (10'6")	R3.75 (12'4")
Hydraulic Hammers		H120 S	✓	✓	✓	✓
		H130 GC	✓	✓		
		H130 GC S	✓	✓	✓	✓
		H130 S	✓	✓	✓	✓
		H140 GC	✓	✓		
		H140 GC S	✓		✓*	✓*
		H140 S	✓	✓	✓	✓
		H160 GC	✓			
		H160 GC S	✓	✓	✓	✓
		H160 S	✓			
	Multi-Processors		MP324 Concrete Cutter Jaw	✓	✓	✓
		MP324 Demolition Jaw	✓	✓	✓	✓*
		MP324 Pulverizer Jaw	✓	✓	✓*	
		MP324 Shear Jaw	✓	✓	✓	✓*
		MP324 Tank Shear Jaw	✓	✓	✓	
		MP324 Universal Jaw	✓	✓	✓	
		MP332 Concrete Cutter Jaw	✓*			
		MP332 Shear Jaw	✓*			
Demolition and Sorting Grapples		G324	✓†	✓	✓†	✓*
		G324 WH-1500	✓†	✓	✓†	
		G324 WH-1800	✓†			
		G332	✓†		✓*†	
Mobile Scrap and Demolition Shears		S3025 Flat Top	✓	✓	✓	✓
Pulverizers		P224 Secondary Pulverizer	✓		✓*	
		P324 Primary Pulverizer	✓	✓	✓*	
Mulchers		HM5515	✓	✓	✓	✓
		HM6015	✓	✓	✓	✓
Compactors (Vibratory Plate)		CVP110	✓	✓	✓	✓
Rotary Cutters		RC20	✓	✓	✓	✓
		RC30	✓	✓	✓	✓

(continued on next page)

# 330 Hydraulic Excavator Specifications

## Attachments Offering Guide (continued)

Not all Attachments are available in all regions. Consult your Cat dealer for configurations available in your region.

Match     
  \* Working range front only     
  † Allowed usage on machine less than 50%     
  No Match

### S70 DEDICATED COUPLER ATTACHMENTS

Boom Type	Stick Length	Reach		Straight	
		R3.2 (10'6")	R3.75 (12'4")	R3.2 (10'6")	R3.75 (12'4")
Hydraulic Hammers	H120 S	✓	✓	✓	✓
	H130 S	✓	✓	✓	✓
	H140 S	✓	✓	✓	✓
Multi-Processors	MP324 Concrete Cutter Jaw	✓	✓	✓	✓
	MP324 Demolition Jaw	✓	✓	✓	✓
	MP324 Pulverizer Jaw	✓	✓	✓	✓*
	MP324 Shear Jaw	✓	✓	✓	✓
	MP324 Tank Shear Jaw	✓	✓	✓	✓*
	MP324 Universal Jaw	✓	✓	✓	✓
Demolition and Sorting Grapples	G324	✓†	✓	✓†	✓
	G324 WH-1500	✓†	✓	✓†	✓*
	G324 WH-1800	✓†	✓	✓*†	
	G324 WH-2000	✓†			
	G332	✓†	✓	✓†	
Mobile Scrap and Demolition Shears	S3025 Flat Top	✓	✓	✓	✓
	S3035 Flat Top	✓		✓*	
Pulverizers	P224 Secondary Pulverizer	✓	✓	✓	✓*
	P324 Primary Pulverizer	✓	✓	✓	✓*
Compactors (Vibratory Plate)	CVP110	✓	✓	✓	✓
Rotary Cutters	RC20	✓	✓	✓	✓
	RC30	✓	✓	✓	✓

### S80 DEDICATED COUPLER ATTACHMENTS

Boom Type	Stick Length	Reach		Straight	
		R3.2 (10'6")	R3.75 (12'4")	R3.2 (10'6")	R3.75 (12'4")
Hydraulic Hammers	H120 S	✓	✓	✓	✓
	H130 GC S	✓	✓	✓	✓
	H130 S	✓	✓	✓	✓
	H140 GC S	✓			✓*
	H140 S	✓	✓	✓	✓
	H160 GC	✓			
	H160 GC S	✓	✓	✓	✓*
	H160 S	✓†			
Multi-Processors	MP324 Concrete Cutter Jaw	✓	✓	✓	✓*
	MP324 Demolition Jaw	✓	✓	✓	✓*
	MP324 Pulverizer Jaw	✓	✓	✓	
	MP324 Shear Jaw	✓	✓	✓	✓*
	MP324 Tank Shear Jaw	✓	✓	✓	✓*
	MP324 Universal Jaw	✓	✓	✓	✓*
Demolition and Sorting Grapples	G324	✓†	✓	✓†	✓*
	G324 WH-1500	✓†	✓	✓†	
	G324 WH-1800	✓†		✓*†	
	G324 WH-2000	✓*†			
	G332	✓†	✓*	✓*†	
Mobile Scrap and Demolition Shears	S3025 Flat Top	✓	✓	✓	✓
Pulverizers	P224 Secondary Pulverizer	✓	✓	✓	
	P324 Primary Pulverizer	✓	✓	✓	
Compactors (Vibratory Plate)	CVP110	✓	✓	✓	✓
Rotary Cutters	RC20	✓	✓	✓	✓
	RC30	✓	✓	✓	✓

(continued on next page)

# 330 Hydraulic Excavator Specifications

## Attachments Offering Guide (continued)

Not all Attachments are available in all regions. Consult your Cat dealer for configurations available in your region.

Match     
  \* Working range front only     
  † Allowed usage on machine less than 50%     
  No Match

### HCS70 DEDICATED COUPLER ATTACHMENTS

Boom Type	Stick Length	Reach		Straight	
		R3.2 (10'6")	R3.75 (12'4")	R3.2 (10'6")	R3.75 (12'4")
Hydraulic Hammers	H120 S	✓	✓	✓	✓
	H130 S	✓	✓	✓	✓
	H140 S	✓	✓	✓	✓
Multi-Processors	MP324 Concrete Cutter Jaw	✓	✓	✓	✓*
	MP324 Demolition Jaw	✓	✓	✓	✓*
	MP324 Pulverizer Jaw	✓	✓	✓	
	MP324 Shear Jaw	✓	✓	✓	✓
	MP324 Tank Shear Jaw	✓	✓	✓	✓*
	MP324 Universal Jaw	✓	✓	✓	✓*
Demolition and Sorting Grapples	G324	✓†	✓	✓†	✓*
	G324 WH-1500	✓†	✓	✓†	✓*
	G324 WH-1800	✓†		✓*†	
	G324 WH-2000	✓†			
	G332	✓†	✓*	✓*†	
Mobile Scrap and Demolition Shears	S3025 Flat Top	✓	✓	✓	✓
	S3035 Flat Top	✓			
Pulverizers	P224 Secondary Pulverizer	✓	✓	✓	✓*
	P324 Primary Pulverizer	✓	✓	✓	✓*
Compactors (Vibratory Plate)	CVP110	✓	✓	✓	✓
Rotary Cutters	RC20	✓	✓	✓	✓
	RC30	✓	✓	✓	✓

### HCS70/55 DEDICATED COUPLER ATTACHMENTS

Boom Type	Stick Length	Reach		Straight	
		R3.2 (10'6")	R3.75 (12'4")	R3.2 (10'6")	R3.75 (12'4")
Hydraulic Hammers	H120 S	✓	✓	✓	✓
	H130 S	✓	✓	✓	✓
	H140 S	✓	✓	✓	✓
Multi-Processors	MP324 Concrete Cutter Jaw	✓	✓	✓	✓*
	MP324 Demolition Jaw	✓	✓	✓	✓*
	MP324 Pulverizer Jaw	✓	✓	✓	
	MP324 Shear Jaw	✓	✓	✓	✓
	MP324 Tank Shear Jaw	✓	✓	✓	✓*
	MP324 Universal Jaw	✓	✓	✓	✓*
Demolition and Sorting Grapples	G324	✓†	✓	✓†	✓*
	G324 WH-1500	✓†	✓	✓†	
	G324 WH-1800	✓†		✓*†	
	G324 WH-2000	✓*†			
	G332	✓†	✓*	✓*†	
Mobile Scrap and Demolition Shears	S3025 Flat Top	✓	✓	✓	✓
Pulverizers	P224 Secondary Pulverizer	✓	✓	✓	
	P324 Primary Pulverizer	✓	✓	✓	
Compactors (Vibratory Plate)	CVP110	✓	✓	✓	✓
Rotary Cutters	RC20	✓	✓	✓	✓
	RC30	✓	✓	✓	✓

(continued on next page)

# 330 Hydraulic Excavator Specifications

## Attachments Offering Guide (continued)

Not all Attachments are available in all regions. Consult your Cat dealer for configurations available in your region.

Match     
  \* Working range front only     
  † Allowed usage on machine less than 50%     
  No Match

### HCS80 DEDICATED COUPLER ATTACHMENTS

Boom Type	Stick Length	Reach		Straight	
		R3.2 (10'6")	R3.75 (12'4")	R3.2 (10'6")	R3.75 (12'4")
Hydraulic Hammers	H120 S	✓	✓	✓	✓
	H130 S	✓	✓	✓	✓
	H140 S	✓	✓	✓	✓
	H160 S	✓†			
Multi-Processors	MP324 Concrete Cutter Jaw	✓	✓	✓	
	MP324 Demolition Jaw	✓	✓	✓	
	MP324 Pulverizer Jaw	✓	✓*	✓*	
	MP324 Shear Jaw	✓	✓	✓	✓*
	MP324 Tank Shear Jaw	✓	✓	✓*	
	MP324 Universal Jaw	✓	✓	✓	
Demolition and Sorting Grapples	G324	✓†	✓	✓†	
	G324 WH-1500	✓†	✓	✓*†	
	G324 WH-1800	✓†			
	G332	✓†			
Mobile Scrap and Demolition Shears	S3025 Flat Top	✓	✓	✓	✓
Pulverizers	P224 Secondary Pulverizer	✓		✓*	
	P324 Primary Pulverizer	✓	✓*	✓*	
Compactors (Vibratory Plate)	CVP110	✓	✓	✓	✓
Rotary Cutters	RC20	✓	✓	✓	✓
	RC30	✓	✓	✓	✓

### TRS23 (PIN-ON TOP/S70 BOTTOM) ATTACHMENTS

Some attachments require more hydraulic flow and are best suited with a machine that has HP2 circuits and a tiltrotator with a high flow swivel. Check the hydraulic capability of your machine and tiltrotator and the requirements of your attachment to ensure a proper match.

Boom Type	Stick Length	Reach		Straight	
		R3.2 (10'6")	R3.75 (12'4")	R3.2 (10'6")	R3.75 (12'4")
Hydraulic Hammers	H120 S	✓	✓	✓	✓
	H130 S	✓	✓	✓	✓
Compactors (Vibratory Plate)	CVP110	✓	✓	✓	✓

**NOTE:** Use hammers on tiltrotators less than 10% of working hours per year or maximum 200 hours per year. Refer to your Operation and Maintenance Manual for recommended hydraulic flow requirements.

### TRS23 (S70 TOP/S70 BOTTOM) ATTACHMENTS

Some attachments require more hydraulic flow and are best suited with a machine that has HP2 circuits and a tiltrotator with a high flow swivel. Check the hydraulic capability of your machine and tiltrotator and the requirements of your attachment to ensure a proper match.

Boom Type	Stick Length	Reach		Straight	
		R3.2 (10'6")	R3.75 (12'4")	R3.2 (10'6")	R3.75 (12'4")
Hydraulic Hammers	H120 S	✓	✓	✓	✓
	H130 S	✓	✓	✓	✓
Compactors (Vibratory Plate)	CVP110	✓	✓	✓	✓

**NOTE:** Use hammers on tiltrotators less than 10% of working hours per year or maximum 200 hours per year. Refer to your Operation and Maintenance Manual for recommended hydraulic flow requirements.

(continued on next page)

# 330 Hydraulic Excavator Specifications

## Attachments Offering Guide (continued)

Not all Attachments are available in all regions. Consult your Cat dealer for configurations available in your region.

Match

\* Working range front only

No Match

### TRS23 (PIN-ON TOP/S80 BOTTOM) ATTACHMENTS

Some attachments require more hydraulic flow and are best suited with a machine that has HP2 circuits and a tiltrotator with a high flow swivel. Check the hydraulic capability of your machine and tiltrotator and the requirements of your attachment to ensure a proper match.

Boom Type	Stick Length		Reach		Straight	
			R3.2 (10'6")	R3.75 (12'4")	R3.2 (10'6")	R3.75 (12'4")
Hydraulic Hammers		H120 S	✓	✓	✓	✓
		H130 GC S	✓	✓	✓	✓*
		H130 S	✓	✓	✓	✓
Compactors (Vibratory Plate)		CVP110	✓	✓	✓	✓

**NOTE:** Use hammers on tiltrotators less than 10% of working hours per year or maximum 200 hours per year. Refer to your Operation and Maintenance Manual for recommended hydraulic flow requirements.

### TRS23 (S80 TOP/S80 BOTTOM) ATTACHMENTS

Some attachments require more hydraulic flow and are best suited with a machine that has HP2 circuits and a tiltrotator with a high flow swivel. Check the hydraulic capability of your machine and tiltrotator and the requirements of your attachment to ensure a proper match.

Boom Type	Stick Length		Reach		Straight	
			R3.2 (10'6")	R3.75 (12'4")	R3.2 (10'6")	R3.75 (12'4")
Hydraulic Hammers		H120 S	✓	✓	✓	✓
		H130 GC S	✓			
		H130 S	✓	✓	✓	✓*
Compactors (Vibratory Plate)		CVP110	✓	✓	✓	✓

**NOTE:** Use hammers on tiltrotators less than 10% of working hours per year or maximum 200 hours per year. Refer to your Operation and Maintenance Manual for recommended hydraulic flow requirements.

### TRS23 (HCS70 TOP/HCS70 BOTTOM) ATTACHMENTS

Some attachments require more hydraulic flow and are best suited with a machine that has HP2 circuits and a tiltrotator with a high flow swivel. Check the hydraulic capability of your machine and tiltrotator and the requirements of your attachment to ensure a proper match.

Boom Type	Stick Length		Reach		Straight	
			R3.2 (10'6")	R3.75 (12'4")	R3.2 (10'6")	R3.75 (12'4")
Hydraulic Hammers		H120 S	✓	✓	✓	✓
		H130 S	✓	✓	✓	✓*
Compactors (Vibratory Plate)		CVP110	✓	✓	✓	✓

**NOTE:** Use hammers on tiltrotators less than 10% of working hours per year or maximum 200 hours per year. Refer to your Operation and Maintenance Manual for recommended hydraulic flow requirements.

### TRS23 (HCS70/55 TOP/HCS70/55 BOTTOM) ATTACHMENTS

Some attachments require more hydraulic flow and are best suited with a machine that has HP2 circuits and a tiltrotator with a high flow swivel. Check the hydraulic capability of your machine and tiltrotator and the requirements of your attachment to ensure a proper match.

Boom Type	Stick Length		Reach		Straight	
			R3.2 (10'6")	R3.75 (12'4")	R3.2 (10'6")	R3.75 (12'4")
Hydraulic Hammers		H120 S	✓	✓	✓	✓
		H130 S	✓	✓	✓	✓*
Compactors (Vibratory Plate)		CVP110	✓	✓	✓	✓

**NOTE:** Use hammers on tiltrotators less than 10% of working hours per year or maximum 200 hours per year. Refer to your Operation and Maintenance Manual for recommended hydraulic flow requirements.

(continued on next page)

# 330 Hydraulic Excavator Specifications

## Attachments Offering Guide *(continued)*

Not all Attachments are available in all regions. Consult your Cat dealer for configurations available in your region.

Match

\* Working range front only

No Match

### TRS23 (HCS80 TOP/HCS80 BOTTOM) ATTACHMENTS

Some attachments require more hydraulic flow and are best suited with a machine that has HP2 circuits and a tiltrotator with a high flow swivel. Check the hydraulic capability of your machine and tiltrotator and the requirements of your attachment to ensure a proper match.

Boom Type	Stick Length	Reach		Straight	
		R3.2 (10'6")	R3.75 (12'4")	R3.2 (10'6")	R3.75 (12'4")
Hydraulic Hammers	H120 S	✓	✓	✓	✓*
	H130 S	✓		✓*	
Compactors (Vibratory Plate)	CVP110	✓	✓	✓	✓

**NOTE:** Use hammers on tiltrotators less than 10% of working hours per year or maximum 200 hours per year. Refer to your Operation and Maintenance Manual for recommended hydraulic flow requirements.

### BOOM-MOUNT ATTACHMENTS

Boom Type		Reach		Straight	
		R3.2 (10'6")	R3.75 (12'4")	R3.2 (10'6")	R3.75 (12'4")
Mobile Scrap and Demolition Shears	S2070	✓		✓	
	S3050	✓		✓	

# 330 Hydraulic Excavator Specifications

## Thumb Specifications

Not all Attachments are available in all regions. Consult your Cat dealer for configurations available in your region.

Match

No Match

Bucket Type	Tooth Quantity	Width		Pro Plus		Pro		Still Link		Utility	
		mm	in	Pin-On	Cat Pin Grabber	Pin-On	Cat Pin Grabber	Pin-On	Cat Pin Grabber	Pin-On	Cat Pin Grabber
General Duty	5	902	36	✓	✓	✓	✓	✓	✓	✓	✓
	5	1056	42	✓	✓	✓	✓	✓	✓	✓	✓
	6	1208	48	✓	✓	✓	✓	✓	✓	✓	✓
	7	1350	54	✓	✓	✓	✓	✓	✓	✓	✓
Heavy Duty	4	902	36	✓	✓	✓	✓	✓	✓	✓	✓
	5	1056	42	✓	✓	✓	✓	✓	✓	✓	✓
	5	1208	48	✓	✓	✓	✓	✓	✓	✓	✓
	6	1350	54	✓	✓	✓	✓	✓	✓	✓	✓
	7	1500	60	✓	✓	✓	✓	✓	✓	✓	✓
	7	1650	66	✓	✓	✓	✓	✓	✓	✓	✓
Heavy Duty Power	5	1080	42		✓			✓	✓	✓	✓
	5	1232	48	✓	✓	✓	✓	✓	✓	✓	✓
	6	1384	54	✓	✓			✓	✓	✓	✓
Severe Duty	4	902	36	✓	✓	✓	✓	✓	✓	✓	✓
	5	1056	42	✓	✓	✓	✓	✓	✓	✓	✓
	5	1208	48	✓	✓	✓	✓	✓	✓	✓	✓
Pin Grabber Performance (HD)	5	1208	48		✓		✓			✓	✓
	6	1350	54		✓		✓			✓	✓
	7	1500	60							✓	✓
Pin Grabber Performance (SD)	4	902	36							✓	✓
	5	1056	42		✓					✓	✓

# 330 Standard and Optional Equipment

## Standard and Optional Equipment

Standard and optional equipment may vary. Consult your Cat dealer for details.

	Standard	Optional		Standard	Optional
<b>CAT TECHNOLOGY</b>			<b>ENGINE</b>		
Cat Equipment Management:			Cat® C7.1 twin turbo diesel engine	✓	
– VisionLink®	✓ <sup>1</sup>		Three selectable modes: Power, Smart, Eco	✓	
– VisionLink Productivity		✓ <sup>2</sup>	Automatic engine speed control	✓	
– Remote Flash	✓		Automatic engine idle-shutdown	✓	
– Remote Troubleshoot	✓		4500 m (14,760 ft) altitude capability with engine power derate above 3000 m (9,840 ft)	✓	
– Work tool recognition and tracking (PL161)	✓		50° C (122° F) high-ambient cooling capability with derate	✓	
– Operator Coaching		✓ <sup>3</sup>	–18° C (0° F) cold start capability	✓	
Cat Grade:			–32° C (–25° F) cold start capability		✓
– Cat Grade with 2D	✓ <sup>4</sup>		Cold start block heaters		✓
– Cat Grade with 2D with Attachment Ready Option (ARO)		✓	2 × 115 Amp dual alternator	✓	
– Laser catcher		✓	Sealed double element air filter with integrated pre-cleaner	✓	
– Cat Grade with 3D (single or dual GNSS)		✓	Two-stage fuel filtration with water separator and indicator	✓	
– Compatible with 3D grade systems from Trimble, Topcon, and Leica	✓		Electric fuel priming pump	✓	
– Cat Grade 3D Ready		✓	Electric cooling fans with auto-reverse function	✓	
– Cat Grade Connectivity		✓ <sup>2</sup>	<b>HYDRAULIC SYSTEM</b>		
Cat Assist: <sup>5</sup>			Electronic main control valve	✓	
– Grade Assist	✓		Electric boom regeneration circuit	✓	
– Boom Assist	✓		Stick regeneration circuit	✓	
– Bucket Assist	✓		Automatic hydraulic oil warm up	✓	
– Swing Assist	✓		Automatic two-speed travel	✓	
– Lift Assist	✓		Boom and stick drift reduction valve	✓	
Cat Payload: <sup>4</sup>			Boom lowering check valve		✓
– On-the-go weighing	✓		Stick lowering check valve		✓
– Semiautomatic calibration	✓		Auto Dig Boost	✓ <sup>6</sup>	
– Payload/cycle information	✓		Auto heavy lift	✓	
– VisionLink Productivity back office reporting		✓ <sup>2</sup>	High performance hydraulic return filter	✓	
Cat Advanced Payload:			Final drive with bio hydraulic oil capable travel motor	✓	
– Daily totals		✓	Fine swing control	✓	
– Custom lists		✓	Advanced Tool Control (two pump, one/two way high-pressure flow)		✓
– Smart weight target		✓	Hammer return filter		✓
– E-ticket Integration		✓ <sup>2</sup>	Hydraulic efficiency monitoring		✓
Other:			Medium-pressure circuit		✓
Cat Tiltrotator (TRS) integration		✓	Common Quick Coupler Circuit for Cat Pin Grabber and CW Dedicated		✓

Cat technology is not compatible with 6.5 m (21'4") Straight boom and 3.75 m (12'4") Reach stick configuration.

<sup>1</sup>Provides core telematics data to manage health, maintenance insights, and condition monitoring. Other plans available for more comprehensive data reporting. Consult your Cat dealer for details.

<sup>2</sup>VisionLink subscription required. Consult your Cat dealer for details.

<sup>3</sup>VisionLink subscription required for back office reporting. Consult your Cat dealer for details.

<sup>4</sup>Optional on machines equipped with a Super Long Reach boom and stick.

<sup>5</sup>Optional on machines equipped with a Super Long Reach boom and stick; Not available with Straight boom.

<sup>6</sup>Requires heavy lift valve; not available for Super Long Reach or Straight boom.

(continued on next page)



## Standard and Optional Equipment (continued)

Standard and optional equipment may vary. Consult your Cat dealer for details.

	Standard	Optional		Standard	Optional
<b>BOOMS, STICKS AND LINKAGES</b>			<b>SAFETY AND SECURITY</b>		
6.15 m (20'2") Reach boom		✓	Cat Command (remote control)		✓
6.5 m (21'4") Straight boom		✓	2D E-Fence:	✓ <sup>4</sup>	
10.2 m (33'6") Super Long Reach boom		✓	– E-ceiling		
3.2 m (10'6") Reach stick		✓	– E-floor		
3.75 m (12'4") Reach stick		✓	– E-swing		
7.85 m (25'9") Super Long Reach stick		✓	– E-wall		
Bucket linkage, CB2 family with lifting eye, Cat Grade		✓	– E-cab avoidance		
Bucket linkage, A family with lifting eye		✓	Auto hammer stop	✓	
<b>UNDERCARRIAGE AND STRUCTURES</b>			Rearview and right-hand-sideview cameras	✓	
Full-length track guiding guards		✓	360° visibility		✓
Segmented track guiding guards	✓		Secure start with PIN code	✓	
Swivel guard	✓		Caterpillar One Key security system	✓	
HD bottom guards	✓		Lockable external tool/storage box	✓	
HD travel motor guards	✓		Lockable door, fuel, and hydraulic tank locks	✓	
Grease lubricated track	✓		Lockable fuel drain compartment	✓	
Swing drive and motor, and swing bearing for higher swing torque	✓		Service platform with anti-skid plate and recessed bolts	✓	
Base frame with HD rollers	✓		RH handrail and hand hold	✓	
Tie-down points on base frame	✓		Cab mirror for RH track edge	✓	
6700 kg (14,770 lb) counterweight	✓		Signaling/warning horn	✓	
600 mm (24") single grouser track shoes		✓	Swing alarm		✓
700 mm (28") HD triple grouser track shoes		✓	Ground-level secondary engine shutoff switch in cab	✓	
800 mm (31") triple grouser track shoes		✓	Lockable disconnect switch	✓	
<b>ELECTRICAL SYSTEM</b>			Hydraulic lock out lever that neutralizes all controls	✓	
Maintenance-free 1,000 CCA batteries (×2)	✓		Travel alarm	✓	
Programmable time-delay LED working lights	✓		Inspection lighting		✓
Centralized electrical disconnect switch	✓		<sup>4</sup> Optional on machines equipped with a Super Long Reach boom and stick.		
LED chassis light, Left Hand (LH) and Right Hand (RH) boom lights, cab lights	✓				
Premium surround lighting package		✓			
<b>SERVICE AND MAINTENANCE</b>					
Grouped location of engine oil and fuel filters	✓				
Ground-level second dipstick for engine oil	✓				
Side entry to service platform	✓				
Scheduled Oil Sampling (S·O·S <sup>SM</sup> ) ports	✓				
QuickEvac <sup>TM</sup> maintenance ready	✓				
Radiator screen		✓			
Integrated vehicle health management system	✓				

# 330 Cab Options

## Cab Options

	Deluxe	Demolition <sup>1</sup>
ROPS	●	●
OPG	○	○
High-resolution 254 mm (10") LCD touchscreen monitor	●	○ <sup>2</sup>
High-resolution 203 mm (8") LCD touchscreen monitor	X	●
Auto bi-level air conditioner	●	●
Jog dial and shortcut keys for monitor control	●	●
Keyless push-to-start engine control	●	●
Height-adjustable console	●	●
Tilt-up left-side console	●	●
Tilt rocker switch	X	●
Sky wiper switch	X	●
Heated air-suspension seat	●	X
Heated and ventilated air-suspension seat	X	●
51 mm (2") seat belt	●	●
Monitor integrated Bluetooth® radio with USB/Auxiliary ports	●	●
12V DC outlets	●	●
Document storage	●	●
Overhead storage and rear storage with nets	●	●
Beverage holder	●	●
Cup holder	●	●
Openable two-piece front window	●	X
One piece front windshield	X	●
Rear window emergency exit	●	●
Radial wiper with washer	●	X
Parallel wiper	X	●
Intermittent roof wiper with washer	X	●
Openable polycarbonate skylight hatch	●	X
Fixed one-piece P5A glass hatch	X	●
Laminated roof glass	X	●
LED dome light	●	●
Floor welcome light	●	●
Roof sunscreen	●	●
Roller front sunscreen	●	●
Roller rear sunscreen	○	○
Washable floor mat	●	●
Beacon ready	●	●
Cat Stick Steer	○	○
Auxiliary relay	○	○

● Standard

○ Optional

X Not Available

<sup>1</sup> for use with 330 Straight boom configuration

<sup>2</sup> For use with 360° visibility

## Dealer Installed Kits and Attachments

Attachments may vary. Consult your Cat dealer for details.

### CAB

- LH/RH electrical pedal (two-way) for tool control
- Dual exit rear window kit
- Radial lower wiper for two piece (70/30) windshield, with washer
- Rain protector plus cab light cover
- 75 mm (3") retractable seat belt

### SAFETY AND SECURITY

- Cat Detect – People Detection
- Cat Command – Remote control kit
- Seat belt indicator
- Bluetooth receiver
- Bluetooth key fob

### GUARDS

- Side rubber bumper guard
- OPG (not compatible with cab light cover, rain protector)
- Mesh guard full front (not compatible with cab light cover, rain protector)
- Mesh guard lower half front
- Full protecting vandalism guard (not compatible with cab light cover, rain protector)

### ELECTRICAL

- Jump start wiring

### SERVICE AND MAINTENANCE

- Grease gun holder

# 330 Environmental Declaration

The following information applies to the machine at the time of final manufacture as configured for sale in the regions covered in this document. The content of this declaration is valid as of the date issued; however, content related to machine features and specifications are subject to change without notice. For additional information, please see the machine's Operation and Maintenance Manual.

For more information on sustainability in action and our progress, please visit <https://www.caterpillar.com/en/company/sustainability>.

## Engine

- The Cat® C7.1 engine meets U.S. EPA Tier 4 Final, EU Stage V, Korea Stage V, and Japan 2014 emission standards.
- Cat diesel engines are required to use ULSD (ultra-low sulfur diesel fuel with 15 ppm of sulfur or less) or ULSD blended with the following lower-carbon intensity fuels\*\* up to:
  - ✓ 20% biodiesel FAME (fatty acid methyl ester)\*
  - ✓ 100% renewable diesel, HVO (hydrogenated vegetable oil) and GTL (gas-to-liquid) fuels

Refer to guidelines for successful application. Please consult your Cat dealer or "Caterpillar Machine Fluids Recommendations" (SEBU6250) for details.

*\*Engines with no aftertreatment devices can use higher blends, up to 100% biodiesel (for use of blends higher than 20% biodiesel, consult your Cat dealer).*

*\*\*Tailpipe greenhouse gas emissions from lower-carbon intensity fuels are essentially the same as traditional fuels.*

## Air Conditioning System

- The air conditioning system on this machine contains the fluorinated greenhouse gas refrigerant R134a (Global Warming Potential = 1430). The system contains 0.85 kg (1.9 lb) of refrigerant which has a CO<sub>2</sub> equivalent of 1.216 metric tonnes (1.340 tons).

## Paint

- Based on best available knowledge, the maximum allowable concentration, measured in parts per million (PPM), of the following heavy metals in paint are:
  - Barium < 0.01%
  - Cadmium < 0.01%
  - Chromium < 0.01%
  - Lead < 0.01%

## Sound Performance

ISO 6395:2008 (external) – 103 dB(A)

ISO 6396:2008 (inside cab) – 70 dB(A)

- Hearing protection may be needed when operating with an open operator station and cab (when not properly maintained or doors/windows open) for extended periods or in a noisy environment.

## Oils and Fluids

- Caterpillar factory fills with ethylene glycol coolants. Cat Diesel Engine Antifreeze/Coolant (DEAC) and Cat Extended Life Coolant (ELC) can be recycled. Consult your Cat dealer for more information.
- Cat Bio HYDO™ Advanced is an EU Ecolabel approved biodegradable hydraulic oil.
- Additional fluids are likely to be present, please consult the Operations and Maintenance Manual or the Application and Installation guide for complete fluid recommendations and maintenance intervals.

## Features and Technology

- The following features and technology may contribute to fuel savings and/or carbon reduction. Features may vary. Consult your Cat dealer for details.
  - Advanced hydraulic systems balance power and efficiency
  - Smart mode matches machine power to digging requirements automatically
  - Eco mode supports reduced fuel consumption for light applications
  - Utilizing Cat technologies can help increase operating efficiencies
  - Extended service intervals help decrease maintenance costs
  - Programmable high-efficiency cooling fans run only when needed
  - The latest hydraulic oil filter provides longer life with a 3,000-hour replacement interval

## Recycling

- The materials included in machines are categorized as below with approximate weight percentage. Because of variations of product configurations, the following values in the table may vary.

Material Type	Weight Percentage
Steel	86.85%
Iron	4.63%
Nonferrous Metal	1.55%
Mixed Metal	0.07%
Mixed-Metal and Nonmetal	0.63%
Plastic	1.79%
Rubber	0.16%
Mixed Nonmetallic	0.23%
Fluid	3.12%
Other	0.96%
Uncategorized	0.00%
Total	100%

- A machine with higher recyclability rate will ensure more efficient usage of valuable natural resources and enhance End-of-Life value of the product. According to ISO 16714:2008 (Earthmoving machinery – Recyclability and recoverability – Terminology and calculation method), recyclability rate is defined as percentage by mass (mass fraction in percent) of the new machine potentially able to be recycled, reused or both.

All parts in the bill of material are first evaluated by component type based on a list of components defined by the ISO 16714:2008 and Japan CEMA (Construction Equipment Manufacturers Association) standards. Remaining parts are further evaluated for recyclability based on material type.

Because of variations of product configurations, the following value in the table may vary.

Recyclability – 97%

For more complete information on Cat products, dealer services, and industry solutions, visit us on the web at [www.cat.com](http://www.cat.com)

© 2024 Caterpillar  
All rights reserved

Materials and specifications are subject to change without notice. Featured machines in photos may include additional equipment. See your Cat dealer for available options.

CAT, CATERPILLAR, LET'S DO THE WORK, their respective logos, "Caterpillar Corporate Yellow," the "Power Edge" and Cat "Modern Hex" trade dress as well as corporate and product identity used herein, are trademarks of Caterpillar and may not be used without permission. VisionLink is a trademark of Caterpillar Inc., registered in the United States and in other countries.

AEXQ4010-00 (10-2024)  
Build Number: 07H  
(N Am)

