



Operation & Maintenance Manual

*Original Instructions
Keep this manual with machine at all times.*

Models TH306D, TH357D, TH408D, TH3510D

SN TD200150 to Present, SN TA200150 to Present
SN TD300150 to Present, SN TA300150 to Present
SN TD600150 to Present, SN TD700150 to Present
SN TH900150 to Present, SN TH400150 to Present
SN TH200150 to Present, SN T7F00150 to Present
SN TH300150 to Present, SN THZ00150 to Present

**31211089
SEBU9961-08**

*Revised
September 28, 2018 - Rev I*

CE

AUS

REVISION LOG

July 7, 2016 - A - Original Issue of Manual.

September 21, 2016 - B - Revised cover and pages c, 2-10 thru 2-12, 3-35, 3-42, 4-17, 5-2, 7-3 thru 7-11, 7-30, 7-31, 7-38, 7-39, 8-1, 9-2, 9-4, 9-6, 9-8.

October 3, 2016 - C - Revised pages 5-1 and 5-26.

December 16, 2016 - D - Revised front cover and pages d, 1-4, 2-4 thru 2-8, 2-11, 3-5, 3-6, 3-9, 3-10, 3-12, 3-31, 4-4, 4-6, 4-18, 5-2 thru 5-4, 5-13, 6-4, 7-7 thru 7-11, 7-13, 7-16 thru 7-18, 7-21, 7-22, 7-24, 7-30, 7-33, 9-5, 9-7, 9-9 thru 9-12 & 9-14 thru 9-18.

February 28, 2017 - E - Revised pages 9-1 thru 9-10.

October 27, 2017 - F - Revised pages b thru d, 1-1, 1-3, 1-14, 1-15, 2-2, 2-4, 2-5, 2-9, 2-14, 2-17, 4-5, 4-18, 5-5, 5-56, 7-27, 7-40 & 9-16 thru 9-19.

November 13, 2017 - G - Revised pages 3-2 thru 3-4, 3-6, 5-66 & 5-67.

January 22, 2018 - H - Revised pages 3-4, 3-6, 3-8, 3-14, 3-15, 3-53 & 3-59.

September 28, 2018 - I - Revised pages 2-4 thru 2-7, 2-9, 2-12, 2-14, 3-2 thru 3-4, 3-8, 3-9, 3-22, 3-23, 3-26, 3-30, 3-35, 3-42, 3-44, 4-8, 4-11, 4-14, 5-2, 5-14 thru 5-19, 5-63, 7-26, 7-37, 7-38, 9-2, 9-4, 9-6, 9-8, 9-16 & 9-17.

Read This First

This manual is a very important tool! Keep it with the machine at all times.

The purpose of this manual is to provide owners, users, operators, lessors, and lessees with the precautions and operating procedures essential for the safe and proper machine operation for its intended purpose.

This machine is a telescopic material handler used to lift and transport materials.

Due to continuous product improvements, the manufacturer reserves the right to make specification changes without prior notification. Contact the local Caterpillar dealer for updated information.

Operator Qualifications

The operator of the machine must not operate the machine until this manual has been read, training is accomplished and operation of the machine has been completed under the supervision of an experienced and qualified operator. Operation within the U.S.A. requires training per OSHA 1910.178.

Operators of this equipment must possess a valid, applicable driver's license, be in good physical and mental condition, have normal reflexes and reaction time, good vision and depth perception and normal hearing. Operator must not be using medication which could impair abilities nor be under the influence of alcohol or any other intoxicant during the work shift.

In addition, the operator must read, understand and comply with instructions contained in the following material furnished with the material handler:

- This Operation & Maintenance Manual
- Telehandler Safety Manual (ANSI only)
- All instructional decals and plates
- Any optional equipment instructions furnished

The operator must also read, understand and comply with all applicable Employer, Industry and Governmental rules, standards and regulations.

Modifications

Modifications to this machine may affect compliance with Industry Standards and/or Governmental Regulations. Any modification must be approved by the manufacturer.

This product must comply with all safety related bulletins. Contact the local Caterpillar dealer representative for information regarding safety-related bulletins which may have been issued for this product.

Other Publications Available

Service ManualUENR6280 (31211253)

Parts Manual

 TH306D M0067954

 TH357D M0078697

 TH408D M0078646

 TH3510D M0067952

Note: The following standards may be referenced in this manual:

ANSI is compliant to ANSI/ITSDF B56.6

AUS is compliant to AS 1418.19

CE is compliant to 2006/42/EC

EAC is compliant to TR CU 010/2011

Refer to the machine Serial Number Plate to identify the applicable compliance standard.

This Page Intentionally Left Blank

TABLE OF CONTENTS

Revision Log

Read This First

Operator Qualifications	b
Modifications.....	b
Other Publications Available	c

Table of Contents

Section 1 - General Safety Practices

1.1 Hazard Classification System	1-1
Safety Alert System and Safety Signal Words.....	1-1
1.2 General Precautions	1-1
1.3 Operation Safety.....	1-2
Electrical Hazards.....	1-2
Tip Over Hazard.....	1-4
Travel Hazard.....	1-7
Load Falling Hazard	1-8
Lifting Personnel.....	1-9
Driving Hazards on Slopes.....	1-10
Pinch Points and Crush Hazards.....	1-11
Fall Hazard.....	1-13
Chemical Hazards	1-14
Battery Hazards.....	1-15

Section 2 - Pre-Operation and Inspection

2.1 Preparation, Inspection and Maintenance.....	2-1
2.2 Pre-Operation Check and Inspection.....	2-2
2.3 Safety Decals	2-4
2.4 Walk-Around Inspection	2-10
2.5 Warm-Up and Operational Checks	2-13
Warm-Up Check	2-13
Operational Check.....	2-13
2.6 Cab.....	2-14
2.7 Enclosed Cab Windows (if equipped)	2-15
Cab Door Window	2-15
Rear Window	2-16
2.8 Engine Hood	2-17

Table of Contents

Section 3 - Controls and Indicators

3.1	General.....	3-1
3.2	Controls	3-2
	Instrument Panel	3-4
	LCD Display.....	3-8
	Left Dash Control Panel.....	3-10
	Right Dash Control Panel.....	3-11
	Agriculture Control Panel (if equipped).....	3-14
	Ignition	3-16
	Park Brake.....	3-17
	Parking Procedure.....	3-17
	Transmission Control Lever (if equipped)	3-18
	Accessory Control Lever (if equipped).....	3-20
	Reversing Fan Switch (if equipped)	3-21
	Load Stability Indicator - LSI	3-22
	Steering Column Adjuster.....	3-24
	Joystick	3-26
3.3	Anti-Theft Functionality (if enabled).....	3-33
	Instrument Panel Input	3-33
	Multifunction Display Input.....	3-33
3.4	Steer Modes	3-34
	Manual Steering Alignment Mode Change	3-34
	All Wheel Assisted Steering Alignment Mode Change.....	3-35
3.5	Operator Seat	3-36
	Operator Presence	3-36
	Adjustments	3-37
	Seat Belt	3-40
3.6	Boom Indicators	3-41
	Boom Extension	3-41
	Boom Angle (if equipped)	3-41
3.7	Reverse Systems (if equipped)	3-42
	Reverse Sensing System.....	3-42
	Reversing Camera (if equipped).....	3-42
3.8	Multifunction Display (if equipped)	3-43
	General Information	3-43
	Multifunction Display and Buttons	3-44
	Home Screen	3-46
	Main Menu	3-49
	Operation and Maintenance	3-58
	Troubleshooting	3-76

Section 4 - Operation

4.1 Engine.....4-1
 Starting the Engine4-1
 Extreme Cold Weather Starting (if equipped)4-2
 Battery Boosted Starting4-3
 Normal Engine Operation.....4-5
 Shut-Down Procedure4-6

4.2 After-Treatment System (ATS) (SN TD200150 to Present,
 SN TA200150 to Present).....4-8
 Stationary Exhaust System Cleaning4-8

4.3 Operating with a Non-Suspended Load 4-10
 Lift Load Safely.....4-10
 Picking Up a Load4-10
 Transporting a Load.....4-11
 Leveling Procedure4-11
 Placing a Load4-12
 Disengaging a Load4-12

4.4 Operating with a Suspended Load 4-13
 Lift Load Safely.....4-13
 Picking Up a Suspended Load.....4-13
 Transporting a Suspended Load4-14
 Leveling Procedure4-14
 Placing a Suspended Load4-15
 Disengaging a Suspended Load4-15

4.5 Road Operation (CE).....4-16

4.6 Loading and Securing for Transport 4-17
 Tie Down4-17
 Lifting4-18

Table of Contents

Section 5 - Attachments and Hitches

5.1	Approved Attachments	5-1
5.2	Unapproved Attachments	5-1
5.3	JLG Supplied Attachments	5-2
5.4	Telehandler/Attachment/Fork Capacity	5-5
5.5	Use of the Capacity Chart	5-6
	Capacity Indicator Locations	5-6
	Sample Capacity Chart (CE)	5-7
	Sample Capacity Chart (AUS)	5-8
	Example	5-10
5.6	Attachment Installation	5-11
	Coupler	5-11
	JD Coupler	5-14
	Manitou Coupler	5-16
	JCB Coupler	5-18
	Hydraulic Operated Attachment	5-20
5.7	Adjusting/Moving Forks	5-21
5.8	Attachment Operation	5-22
	Carriage with Forks	5-23
	Fork Positioning Carriage	5-24
	Side Tilt Carriage and Fork Rotator Carriage	5-26
	Side Shift Carriage	5-28
	Fork Extension	5-30
	Pipe Grapple	5-32
	Dual Tine Bale	5-34
	Bale Handler	5-36
	Bucket	5-38
	Multi-Purpose Bucket	5-40
	Grapple Bucket	5-42
	Manure Grapple	5-44
	Muck Fork	5-46
	Sweeper	5-48
	Auger	5-50
	Concrete Bucket Mixer	5-52
	Truss Boom	5-54
	Coupler Mounted Hook	5-56
	Fork Mounted Hook	5-58
	Trash Hopper - Fork Mounted	5-60

5.9	Hitches and Trailer Brakes	5-62
	Retrieval Hitch	5-63
	Fixed Hitch.....	5-64
	Pin Hitch - CUNA C (Italy)	5-65
	Pin Hitch - CUNA D2 (Italy)	5-66
	EEC Manual Pin Hitch	5-67
	EEC Auto Hitch	5-68
	Piton Frame and EEC Auto Hitch.....	5-69
	Hydraulic Hitch	5-70
	Rear Auxiliary Hydraulics.....	5-71
	Trailer Brakes	5-72

Section 6 - Emergency Procedures

6.1	Towing a Disabled Product.....	6-1
	Moving Short Distances	6-1
	Moving Longer Distance.....	6-1
6.2	Emergency Lowering of Boom	6-2
6.3	Emergency Exit from Enclosed Cab.....	6-3
	Rear Window Inside Cab	6-3
	Rear Window Outside Cab (if equipped).....	6-4
	Right Side Window (Agriculture).....	6-4

Section 7 - Lubrication and Maintenance

7.1	Introduction	7-1
	Clothing and Safety Gear	7-1
7.2	General Maintenance Instructions.....	7-2
7.3	Service and Maintenance Schedules.....	7-3
	10 & 1st 50 Hour Maintenance Schedule - TH306D	7-3
	50, 1st 250 & 250 Hour Maintenance Schedule - TH306D.....	7-4
	500, 750 & 1000 Hour Maintenance Schedule - TH306D.....	7-5
	1500, 2000 & 3000 Hour Maintenance Schedule - TH306D.....	7-6
	10 & 1st 50 Hour Maintenance Schedule - TH357D, TH408D, TH3510D	7-7
	50, 1st 250 & 250 Hour Maintenance Schedule - TH357D, TH408D, TH3510D	7-8
	500, 750 & 1000 Hour Maintenance Schedule - TH357D, TH408D, TH3510D	7-9
	1500, 2000 & 3000 Hour Maintenance Schedule - TH357D, TH408D, TH3510D	7-10
	6000 & 12000 Hour Maintenance Schedule - TH357D, TH408D, TH3510D	7-11
7.4	Lubrication Schedules	7-12
	TH306D	7-12
	TH357D, TH408D, TH3510D	7-13

Table of Contents

7.5	Operator Maintenance Instructions	7-15
	Engine Maintenance Components	7-15
	Fuel System	7-20
	Emission System (SN TD200150 to Present, SN TA200150 to Present, SN TD600150 to Present, SN TH900150 to Present, SN TH200150 to Present, SN T7F00150 to Present)	7-22
	Engine Oil	7-23
	Air Intake System	7-24
	Tires	7-26
	Hydraulic Oil	7-28
	Transmission Oil (TH357D, TH408D, TH3510D)	7-30
	Brake Fluid	7-32
	Engine Cooling System	7-33
	Windshield Washer System (if equipped)	7-34
	Cab Air Filters (if equipped)	7-36
	Load Stability Indicator System	7-38
	Jacking Up Machine	7-40

Section 8 - Additional Checks

8.1	General	8-1
8.2	Reverse Sensing System (if equipped)	8-1

Section 9 - Specifications

9.1	Product Specifications	9-1
	Fluids	9-1
	Capacities	9-9
	Tires	9-11
	Performance	9-12
	Dimensions	9-14
	Declaration of Vibration	9-16
	Noise Emission Level (CE)	9-17
	Machine Towing Capacity	9-18

Index

Inspection, Maintenance and Repair Log

SECTION 1 - GENERAL SAFETY PRACTICES

1.1 HAZARD CLASSIFICATION SYSTEM

Safety Alert System and Safety Signal Words



DANGER indicates an imminently hazardous situation which, if not avoided, will result in death or serious injury.



WARNING indicates a potentially hazardous situation which, if not avoided, could result in death or serious injury.



CAUTION indicates a potentiality hazardous situation which, if not avoided, may result in minor or moderate injury.

1.2 GENERAL PRECAUTIONS



Before operation, read and understand this manual. Failure to comply with the safety precautions listed in this manual could result in machine damage, property damage, personal injury or death.

- Hydraulic cylinders are subject to thermal expansion and contraction. This may result in changes to the boom and/or attachment position while the machine is stationary. Factors affecting thermal movement can include the length of time machine is stationary, hydraulic oil temperature, ambient air temperature and boom and/or attachment position.
- Precautions to avoid all hazards in the work area must be taken by the user before and during operation of the machine.
- Some machine surfaces and components may become hot during operation. Avoid touching hot parts. Allow machine surfaces and components to cool before handling.

Section 1- General Safety Practices

1.3 OPERATION SAFETY

Note: The manufacturer has no direct control over machine application and operation. Therefore, safety issues listed in this manual are non-exhaustive. The user and operator are responsible for conforming with good safety practices.

Electrical Hazards

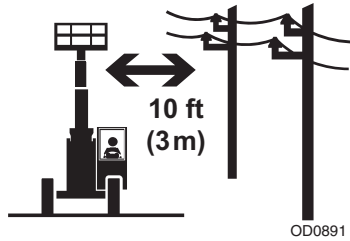
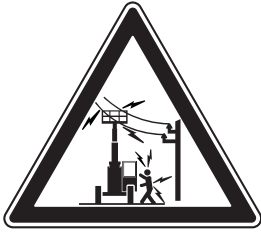

- This machine is not insulated and does not provide protection from contact or being near electrical current.
- Always check for power lines before raising the boom.
- Maintain distance from electrical lines, apparatus, or any energized (exposed or insulated) parts according to the Minimum Approach Distance (MAD).

Voltage Range (Phase to Phase)	Minimum Approach Distance (MAD)
0 to 50 KV	10 ft (3 m)
Over 50KV to 200 KV	15 ft (5 m)
Over 200 KV to 350 KV	20 ft (6 m)
Over 350 KV to 500 KV	25 ft (8 m)
Over 500 KV to 750 KV	35 ft (11 m)
Over 750 KV to 1000 KV	45 ft (14 m)

Note: This requirement shall apply except where employer, local or governmental regulations are more stringent.

- Allow for machine movement and electrical line swaying.
- Maintain a clearance of at least 10 ft (3m) between any part of the machine and its occupants, their tools and their equipment from any electrical line or apparatus carrying up to 50,000 volts. One foot additional clearance is required for every additional 30,000 volts or less.

Section 1- General Safety Practices

- The minimum approach distance may be reduced if insulating barriers are installed to prevent contact, and the barriers are rated for the voltage of the line being guarded. These barriers shall not be part of (or attached to) the machine. The minimum approach distance shall be reduced to a distance within the designed working dimensions of the insulating barrier. This determination shall be made by a qualified person in accordance with the employer, local, or governmental requirements for work practices near energized equipment.



DANGER

Do not maneuver machine or personnel inside prohibited zone (MAD). Assume all electrical parts and wiring are energized unless known otherwise.

- It is not recommended to use the machine during lightning. To prevent injury or machine damage if lightning occurs during operation, lower the boom and shut down the machine in a safe and secure location.

Section 1- General Safety Practices

Tip Over Hazard

General

- For additional load requirements, refer to the appropriate capacity chart.

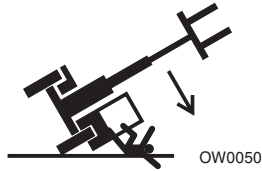

- Never use an attachment without the appropriate original equipment manufacturer (OEM) approved capacity chart installed on the telehandler.
- Understand how to properly use the capacity charts located in cab.
- **DO NOT** exceed rated lift capacity.
- Be sure that the ground conditions are able to support the machine.
- Be aware of wind conditions. Wind may cause load swing and dangerous side loads.

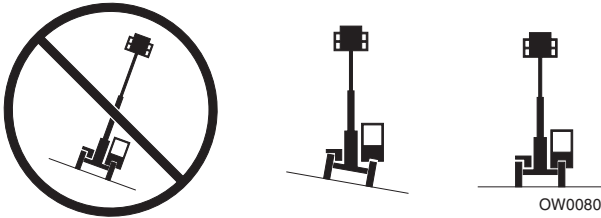

- **DO NOT** raise boom unless frame is level (0 degrees), unless otherwise noted on capacity chart.

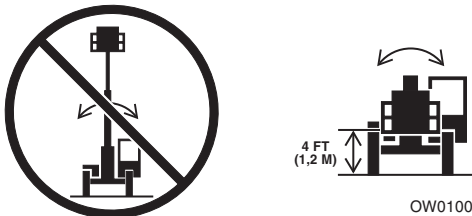

- **DO NOT** level machine with boom/attachment above 4 ft (1,2 m).
(AUS - **DO NOT** level machine with load more than 11.8 in (300 mm) above ground surface.)

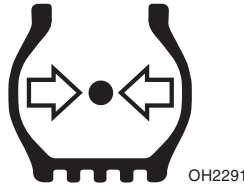

- **MAINTAIN proper tire pressure** at all times. If proper tire pressures are not maintained, this machine could tip over.
- Refer to manufacturer's specifications for proper fill ratio and pressure requirements for tires equipped with ballast.



- Always wear seat belt.
- Keep head, arms, hands, legs and all other body parts inside operator's cab at all times.



If telehandler starts to tip over:

- **DO NOT JUMP**
- **BRACE YOURSELF** and **STAY WITH THE MACHINE**
- **KEEP YOUR SEAT BELT FASTENED**
- **HOLD ON FIRMLY**
- **LEAN AWAY FROM THE POINT OF IMPACT**

Section 1- General Safety Practices

Non-Suspended Load



OD0901

- **DO NOT** drive with boom raised.

Suspended Load

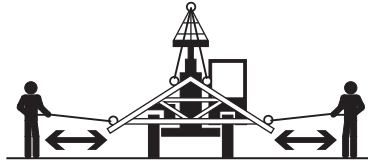
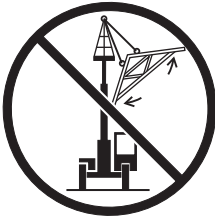

OW0150

- Tether suspended loads to restrict movement.
- Weight of all rigging (slings, etc.) must be included as part of load.
- **DO NOT** attempt to use telehandler frame-leveling to compensate for load swing.
- Keep heavy part of load closest to attachment.
- Never drag the load; lift vertically.

When driving with a suspended load:

- Start, travel, turn and stop slowly to prevent load from swinging.
- **DO NOT** extend boom.
- **DO NOT** raise the load more than 300 mm (11.8 in) above ground surface or the boom more than 45°.
- **DO NOT** exceed walking speed.

Travel Hazard

2-WHEEL FRONT STEER

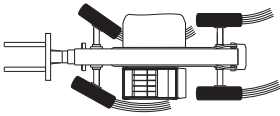

4-WHEEL CIRCLE STEER

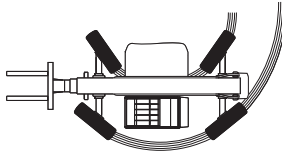

4-WHEEL CRAB STEER

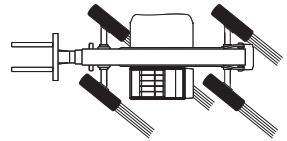

OAL2030

- Steering characteristics differ between steer modes. Identify the steer mode settings of the telehandler being operated.
- **DO NOT** change steer modes while traveling. Steer modes must be changed while telehandler is stationary.
- Visually verify proper wheel alignment after each steer mode change.
- Ensure that adequate clearance is provided for both rear tail swing and front fork swing.
- Look out for and avoid other personnel, machinery and vehicles in the area. Use a spotter if you DO NOT have a clear view.
- Before moving be sure of a clear path and sound horn.
- When driving, retract boom and keep boom/attachment as low as possible while maintaining visibility of mirrors and maximum visibility of path of travel.
- Always look in the direction of travel.
- Always check boom clearances carefully before driving underneath overhead obstructions. Position attachment/load to clear obstacles.
- When driving in high speed, use only front wheel steer (if steering modes are selectable).
- Telehandlers equipped with solid or foam filled tires should not be used in applications requiring excessive roading or driving extended distances. In the event an application requires excessive roading or driving expanded distances, it is recommended to use telehandlers not equipped with solid or foam filled tires.

Section 1- General Safety Practices

Load Falling Hazard

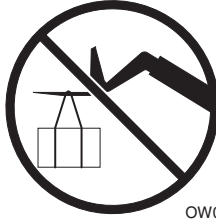

OW0130

- Never suspend load from forks or other parts of carriage weldment. Use only approved lift points.
- **DO NOT** burn or drill holes in fork(s).
- Forks must be centered under load and spaced apart as far as possible.

Lifting Personnel

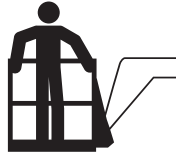

OW0171

- When lifting personnel, **USE ONLY** an approved personnel work platform, with proper capacity chart displayed in the cab.



OD0921

- **DO NOT** drive machine from cab when personnel are in platform.

Section 1- General Safety Practices

Driving Hazards on Slopes

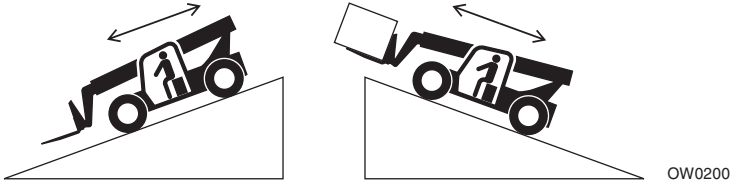

To maintain sufficient traction and braking capabilities, travel on slopes as follows:

- When unloaded, drive with forks pointed downhill.
- When loaded, drive with the forks pointed uphill.
- For additional travel requirements, refer to the appropriate capacity chart.
- To avoid overspeeding the engine and drivetrain when driving down slopes, downshift to a lower gear and use the service brake as necessary to maintain a slow speed. **DO NOT shift into neutral and coast downhill.**
- Avoid excessively steep slopes or unstable surfaces. To avoid tip over **DO NOT** drive across excessively steep slopes under *any* circumstances.
- Avoid turning on a slope. Never engage “inching” or shift to “Neutral” when going downhill.
- **DO NOT** park on a slope.

Pinch Points and Crush Hazards

Stay clear of pinch points and rotating parts on the telehandler.

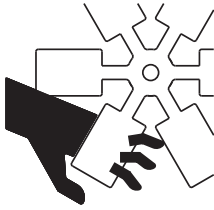

OW0210

- Stay clear of moving parts while engine is running.



OW0220

- Keep clear of steering tires and frame or other objects.



OW0230

- Keep clear from under boom.

Section 1- General Safety Practices



OW0240

- Keep clear of boom holes.



OW0250

- Keep arms and hands clear of attachment tilt cylinder.



OW0260

- Keep hands and fingers clear of carriage and forks.

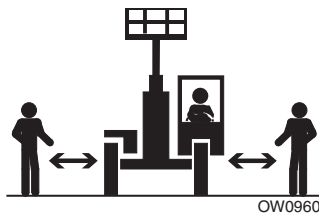

OW0960

- Keep others away while operating.

Fall Hazard



- Enter using the proper hand holds and steps provided. Always maintain 3-point contact when mounting or dismounting. Never grab control levers or steering wheel when mounting or dismounting the machine.
- **DO NOT** get off the machine until the shutdown procedure on page 4-6 has been performed.



- **DO NOT** carry riders. Riders could fall off machine causing death or serious injury.

Section 1- General Safety Practices

Chemical Hazards

Exhaust Fumes

- **DO NOT** operate machine in an enclosed area without proper ventilation.
- **DO NOT** operate the machine in hazardous environments unless approved for that purpose. Sparks from the electrical system and the engine exhaust can cause an explosion.

Flammable Fuel



OW0300

- **DO NOT** fill the fuel tank or service the fuel system near an open flame, sparks or smoking materials. Engine fuel is flammable and can cause a fire and/or explosion.

Hydraulic Fluid



OW0950

- **DO NOT** attempt to repair or tighten any hydraulic hoses or fittings while the engine is running or when the hydraulic system is under pressure.
- Stop engine and relieve trapped pressure. Fluid in the hydraulic system is under enough pressure that it can penetrate the skin.
- **DO NOT** use your hand to check for leaks. Use a piece of cardboard or paper to search for leaks. Wear gloves to protect hands from spraying fluid.

Battery Hazards

- Always disconnect batteries when servicing electrical components or when performing welding on the machine.
- Do not allow smoking, open flame or sparks near battery during charging or servicing.
- Do not contact tools or other metal objects across the battery terminals.
- Always wear hand, eye and face protection when servicing batteries. Ensure that battery acid does not come in contact with skin or clothing.



CAUTION

Battery fluid is highly corrosive. Avoid contact with skin and clothing at all times. Immediately rinse any contacted area with clean water and seek medical attention.

- Charge batteries only in a well ventilated area.

This Page Intentionally Left Blank

SECTION 2 - PRE-OPERATION AND INSPECTION

2.1 PREPARATION, INSPECTION AND MAINTENANCE

The following table covers the periodic machine inspections and maintenance required. Consult local regulations for further requirements for telehandlers. The frequency of inspections and maintenance must be increased as necessary when the machine is used in a harsh or hostile environment, if the machine is used with increased frequency, or if the machine is used in a sever manner.

Inspection and Maintenance				
Type	Frequency	Primary Responsibility	Service Qualification	Reference
Pre-Operation Inspection	Beginning of each work shift or at each change of operator.	User or Operator	User or Operator	Operation & Maintenance Manual
Pre-Delivery Inspection (see note)	Before each sale, lease or rental delivery.	Owner, Dealer or User	Qualified Mechanic	Service Manual and applicable Inspection form.
Preventative Maintenance	At intervals as specified in the Service Manual and/ or the Maintenance Charts located on the machine.	Owner, Dealer or User	Qualified Mechanic	Service Manual and Maintenance Charts

Note: *Inspection forms are available.*

Section 2- Pre-Operation and Inspection

2.2 PRE-OPERATION CHECK AND INSPECTION

Note: Complete all required maintenance before operating unit.



WARNING

FALL HAZARD. Use extreme caution when checking items beyond your normal reach. Use an approved ladder.

The pre-operation check and inspection, performed at beginning of each work shift or at each change of operator, should include the following:

1. **Cleanliness** - Check all surfaces for leakage (oil, fuel or battery fluid) or foreign objects. Report any leakage to the proper maintenance personnel.
2. **Structure** - Inspect the machine structure for dents, damage, weld or parent metal cracks or other discrepancies.

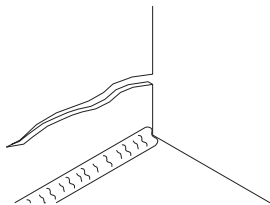

PARENT METAL CRACK

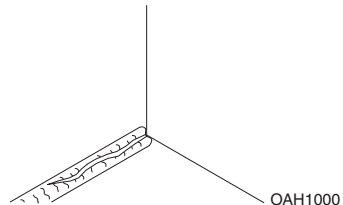

WELD CRACK

OAH1000

3. **Safety Decals** - Ensure all safety decals are legible and in place. Clean or replace as required. See page 2-4 for details.
4. **Operation and Safety Manuals** - Operation & Maintenance Manual and AEM Safety Manual (ANSI only) located in cab manual holder.
5. **Walk-Around Inspection** - See page 2-10 for details.
6. **Fluid Levels** - Check fluids, including fuel, diesel exhaust fluid (DEF), hydraulic oil, engine oil and coolant. When adding fluids, refer to Section 7- Lubrication and Maintenance and Section 9- Specifications to determine proper type and intervals. Before removing filler caps or fill plugs, wipe all dirt and grease away from the ports. If dirt enters these ports, it can severely reduce component life.
7. **Attachments/Accessories** - Ensure correct capacity charts are installed on telehandler. If provided, reference Operation & Maintenance Manual of each attachment or accessory installed for specific inspection, operation and maintenance instructions.

Section 2- Pre-Operation and Inspection

- Operational Check** - Once the walk-around inspection is complete, perform a warm-up and operational check (see page 2-13) of all systems in an area free of overhead and ground level obstructions. See Section 3- Controls and Indicators for more specific operating instructions.



WARNING

If telehandler does not operate properly, immediately bring machine to a stop, lower boom and attachment to ground and stop the engine. Determine cause and correct before continued use.

Section 2- Pre-Operation and Inspection

2.3 SAFETY DECALS

Ensure all **DANGER, WARNING, CAUTION** and instructional decals and proper capacity charts are legible and in place. Clean and replace as required.

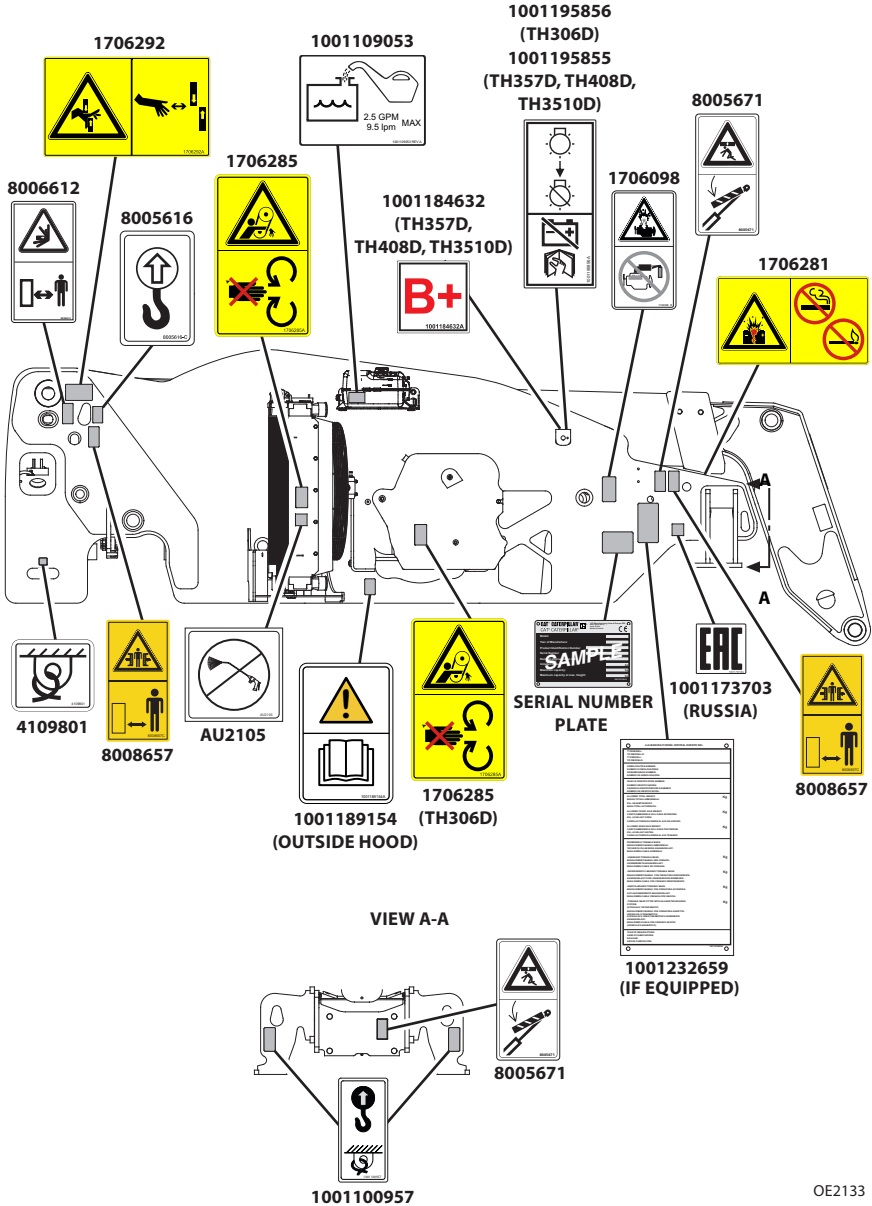

OE2133

Section 2- Pre-Operation and Inspection

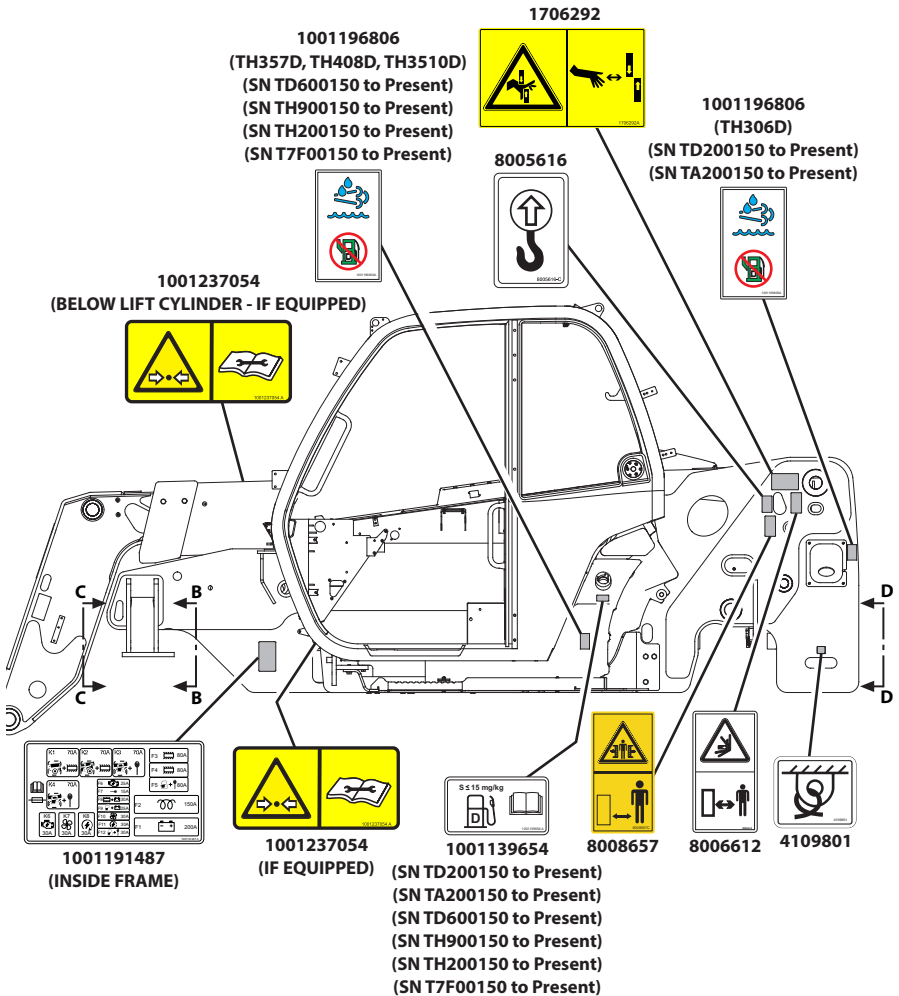

VIEW B-B

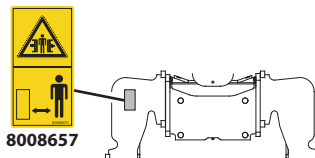

OE2143

Section 2- Pre-Operation and Inspection

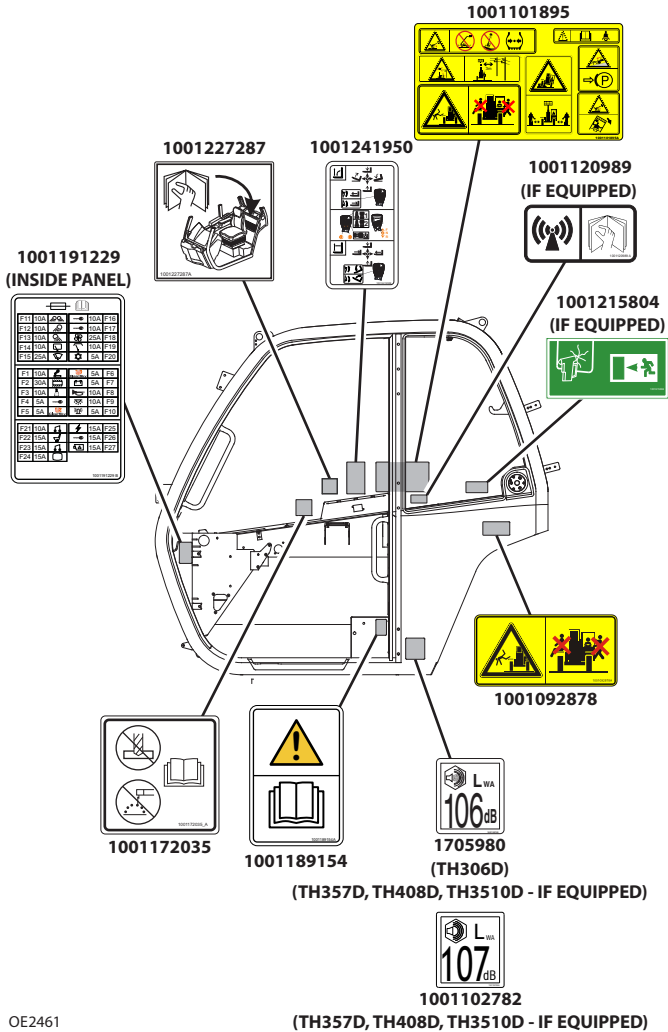

Section 2- Pre-Operation and Inspection

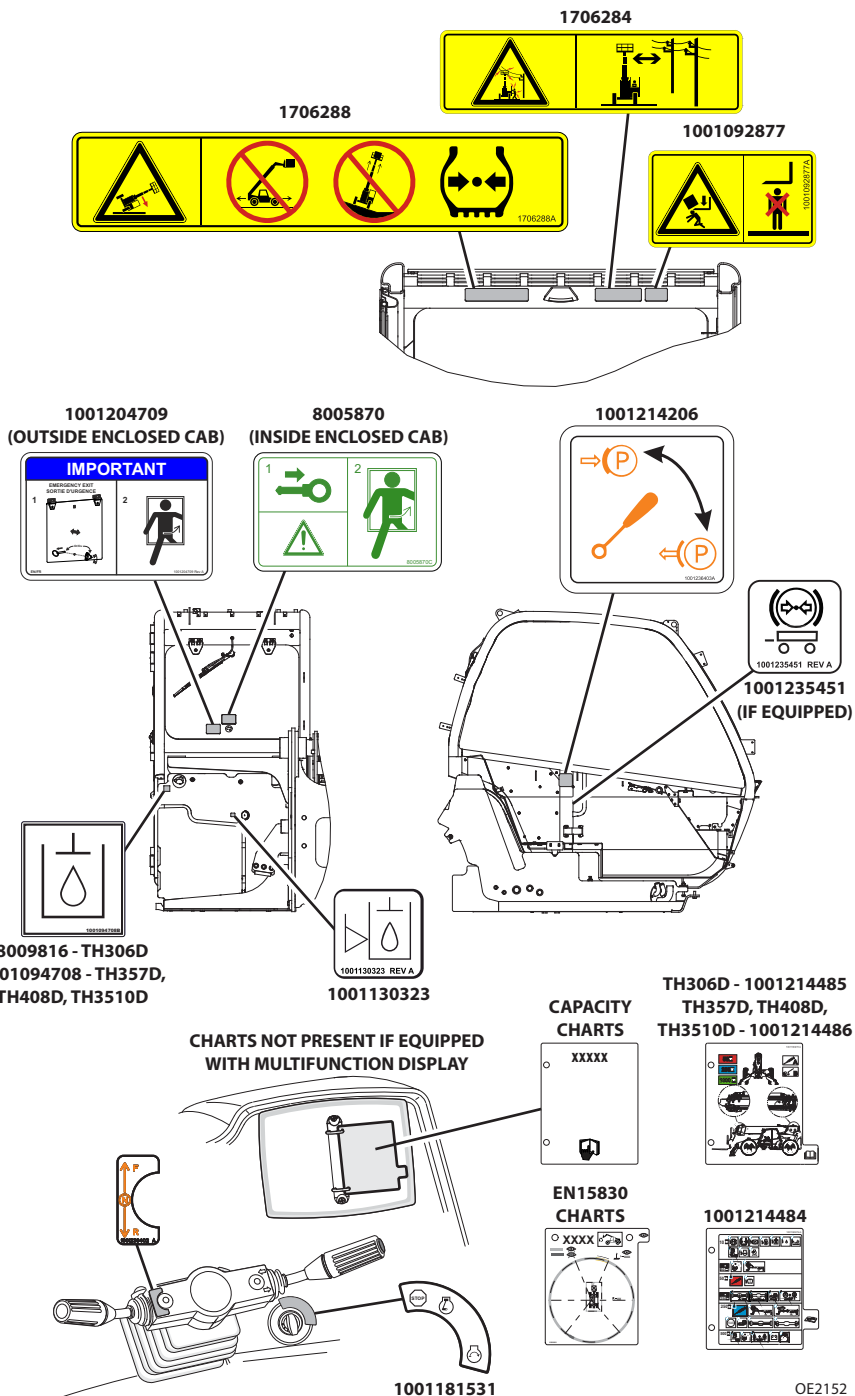

Section 2- Pre-Operation and Inspection

1001216578 (TH306D)

A B C D

1001217423 (TH357D, TH408D, TH3510D)

A B C D E F G H

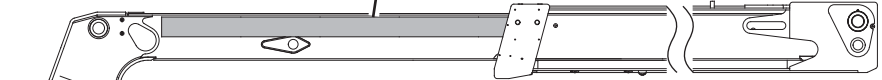

8005675

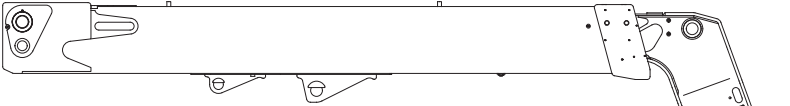

8005675

1001223875

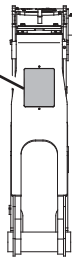

OE2371

VIEW C-C

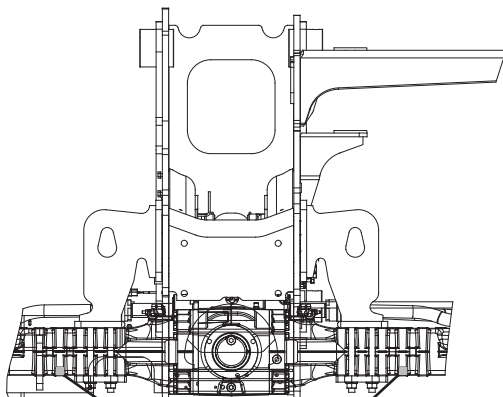

1001230296 REV A

1001230296

VIEW D-D

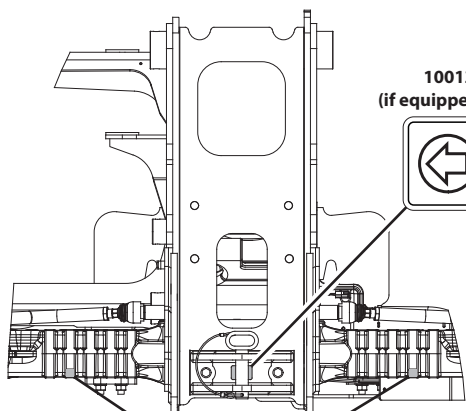

1001241674
(if equipped with hitch)



1001230296 REV A

1001230296

OE2801

Section 2- Pre-Operation and Inspection

2.4 WALK-AROUND INSPECTION

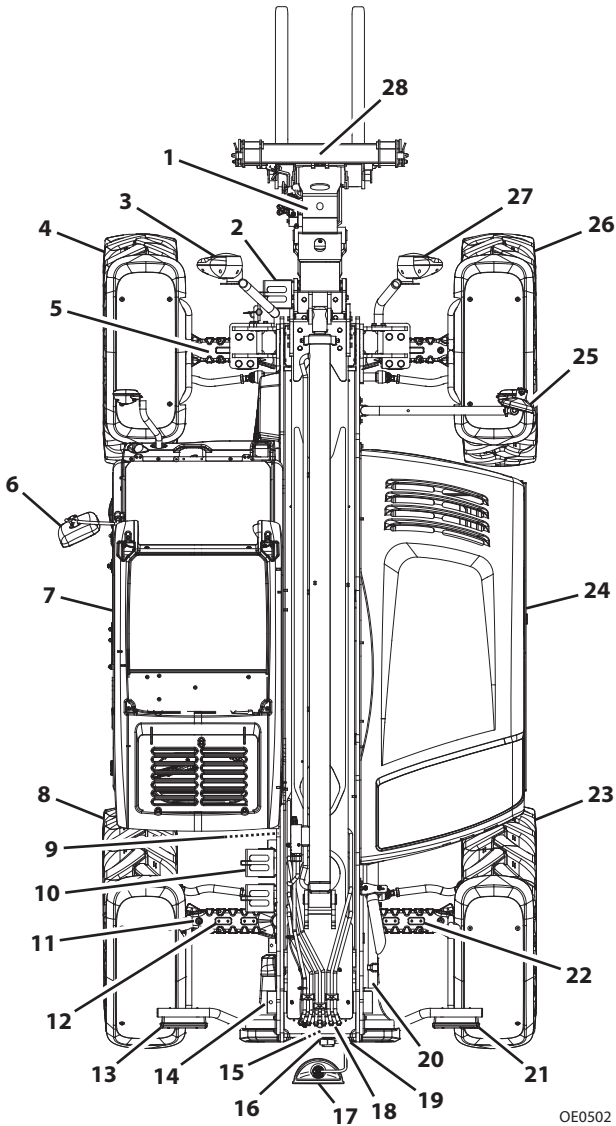

Begin your walk-around inspection at item 1, as noted below. Continue to your right (counterclockwise when viewed from top) checking each item in sequence.

INSPECTION NOTE: On all components, make sure there are no loose or missing parts, that they are securely fastened and no visible leaks or excessive wear exists in addition to any other criteria mentioned. Inspect all structural members including attachment for cracks, excessive corrosion and other damage.

Section 2- Pre-Operation and Inspection

1. **Boom Sections and Lift, Tilt, Extend/Retract, Compensating Cylinders** -
 - Check front, top, side and rear wear pads for presence of grease.
 - Pivot pins secure; hydraulic hoses undamaged, not leaking.
2. **Wheel Chock (TH306D - if equipped)** - See inspection note.
3. **Front Lights (if equipped)** - Clean and undamaged.
4. **Wheel/Tire Assembly** - Properly inflated and secured; no loose or missing lug nuts. Inspect for worn tread, cuts, tears or other discrepancies.
5. **Front Axle** - Steer cylinders undamaged, not leaking; pivot pins secure; hydraulic hoses undamaged, not leaking.
6. **Mirror** - Clean and undamaged.
7. **Cab and Electrical** -
 - General appearance; no visible damage.
 - Frame level indicator(s) and window glass undamaged and clean.
 - Gauges, switches, joystick, foot controls and horn operational.
 - Check seat belt for damage, replace belt if frayed or cut webbing, damaged buckles or loose mounting hardware.
8. **Wheel/Tire Assembly** - Properly inflated and secured; no loose or missing lug nuts. Inspect for worn tread, cuts, tears or other discrepancies.
9. **Main Control Valve (TH306D)** - See inspection note.
10. **Wheel Chock (TH357D, TH408D, TH3510D - if equipped)** - See inspection note.
11. **Rear Axle** - Steer cylinders undamaged, not leaking; pivot pins secure; hydraulic hoses undamaged, not leaking.
12. **LSI Sensor (TH306D)** - See inspection note.
13. **Rear Lights (if equipped)** - Clean and undamaged. See "Road Operation (CE)" on page 4-16.
14. **Boom Angle Sensor** - See inspection note.
15. **Main Control Valve (TH357D, TH408D, TH3510D)** - See inspection note.
16. **Reversing Camera (if equipped)** - See inspection note.
17. **Mirror (if equipped)** - Clean and undamaged.
18. **Boom Retract Sensor** - See inspection note.
19. **Reverse Sensing Sensor (if equipped)** - See inspection note.
20. **Boom Prop (if equipped)** - See inspection note.
21. **Rear Lights (if equipped)** - Clean and undamaged. See "Road Operation (CE)" on page 4-16.
22. **LSI Sensor (TH357D, TH408D, TH3510D)** - See inspection note.

Section 2- Pre-Operation and Inspection

23. Wheel/Tire Assembly - Properly inflated and secured; no loose or missing lug nuts. Inspect for worn tread, cuts, tears or other discrepancies.

24. Engine Compartment -

- Drive belts, check condition and replace as required.
- Engine mounts - See inspection note.
- Power Distribution Plate - No damage or corrosion on connections or wiring.
- Engine cover properly secured.

25. Mirrors - Clean and undamaged.

26. Wheel/Tire Assembly - Properly inflated and secured; no loose or missing lug nuts. Inspect for worn tread, cuts, tears or other discrepancies.

27. Front Lights (if equipped) - Clean and undamaged.

28. Attachment - Properly installed, see See "Attachment Installation" on page 5-11.

2.5 WARM-UP AND OPERATIONAL CHECKS

Warm-Up Check

During warm-up period, check:

1. Heater, air conditioning and wipers (if equipped).
2. Check all lighting systems (if equipped) for proper operation.
3. Adjust mirrors for maximum visibility.



WARNING

CUT/CRUSH/BURN HAZARD. Keep engine cover closed while engine is running except when checking transmission oil level.

Operational Check

When engine warms, perform an operational check:

1. Service brake and parking brake operation.
2. Forward and reverse travel.
3. Each gear.
4. Steering in both directions with engine at low idle (steering lock to lock will not be reached). Check in each steering mode.
5. Horn and back-up alarm. Must be audible from inside operators cab with engine running.
6. All joystick functions operate smoothly and correctly.
7. Perform any additional checks described in Section 8.

Section 2- Pre-Operation and Inspection

2.6 CAB

The telehandler is equipped with an enclosed ROPS/FOPS cab.

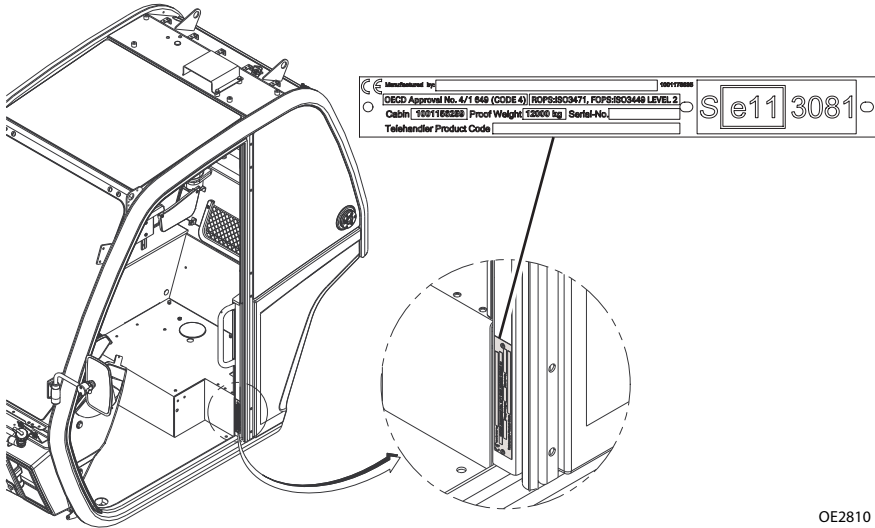

OE2810



WARNING

Never operate telehandler unless the overhead guard, cab structure and right side glass or screen are in good condition. Any modification to this machine must be approved by the manufacturer to assure compliance with ROPS/FOPS certification for this cab/machine configuration. If the overhead guard or cab structure is damaged, the **CAB CANNOT BE REPAIRED**. It must be **REPLACED**.



WARNING

Never drill, cut, and/or weld to cab. Any modification to this machine must be approved by the manufacturer to assure compliance with machine configuration. If unauthorized drilling, cutting and/or welding is present, the cab must be **REPLACED**.

2.7 ENCLOSED CAB WINDOWS (IF EQUIPPED)

Keep all windows clean and unobstructed.

Cab Door Window

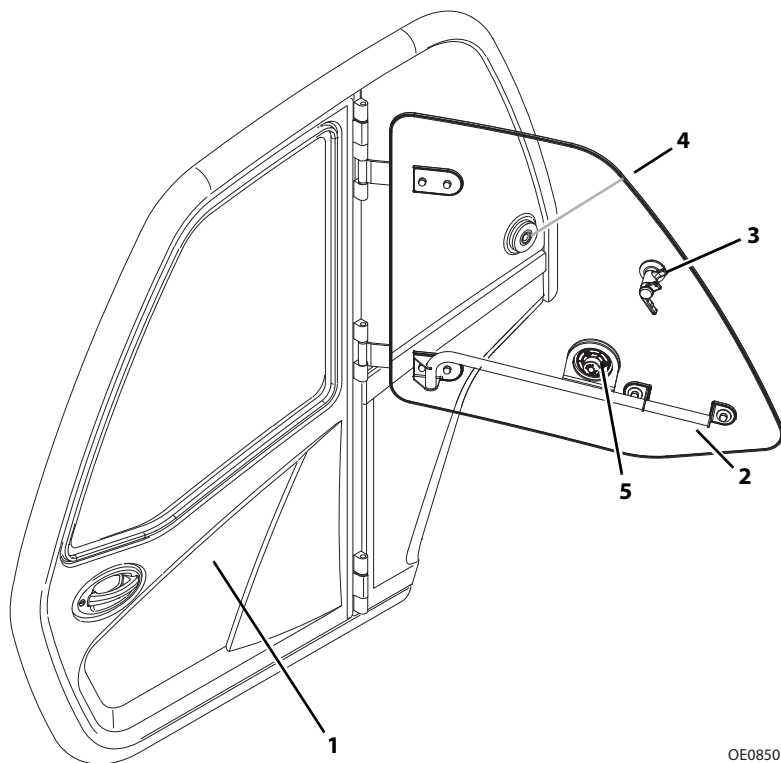

OE0850

- During operation the cab door window (2) must either be latched open or closed.
- Open the cab door window using lever (3) and secure it in the latch (4).
- Press release (4) inside cab or (5) outside cab to unlatch window.

NOTICE

EQUIPMENT DAMAGE. Cab door (1) must be closed during operation. Failure to do so may result in machine damage.

Section 2- Pre-Operation and Inspection

Rear Window

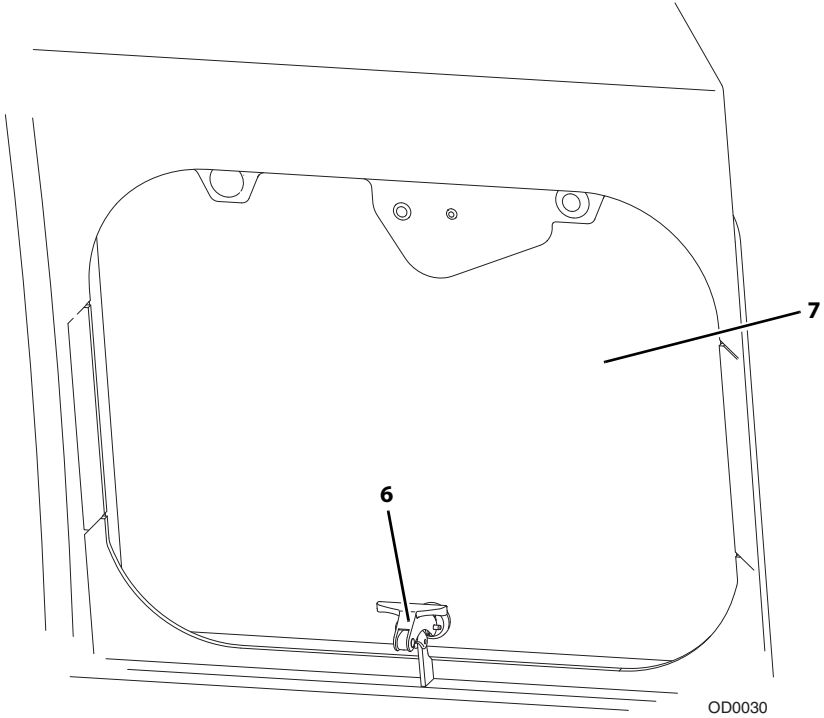

- Lift lever (6) and push to open the rear window (7).
- Lift lever and pull to close.

2.8 ENGINE HOOD

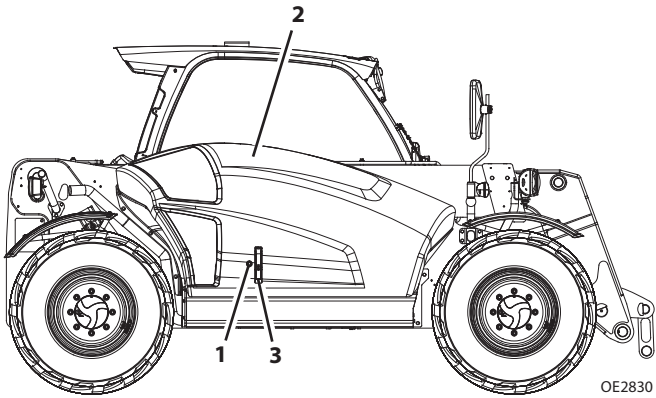

- Engine hood must be closed during operation.
- Insert key into key barrel (1) to unlock hood (2). Raise hood latch (3) and lift hood to open.
- Push hood down and secure hood latch to close. Lock hood using key in key barrel.

This Page Intentionally Left Blank

SECTION 3 - CONTROLS AND INDICATORS

3.1 GENERAL

This section provides the necessary information needed to understand control functions.

Section 3- Controls and Indicators

3.2 CONTROLS

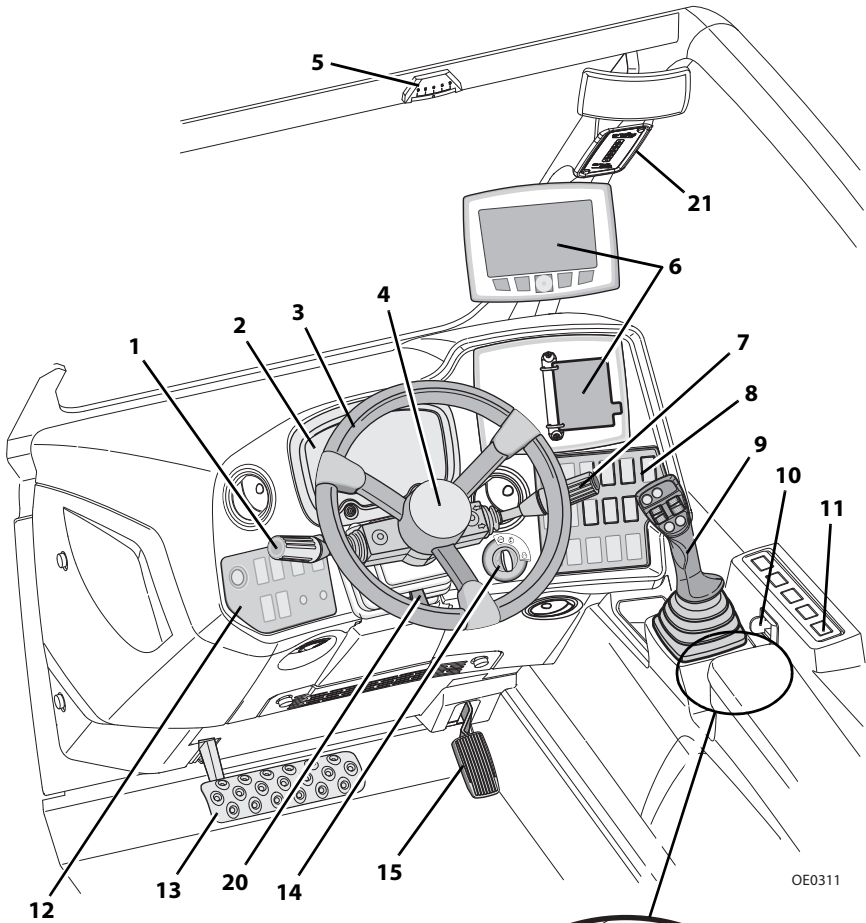

OE0311

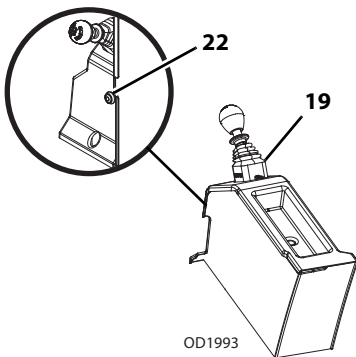

OD1993

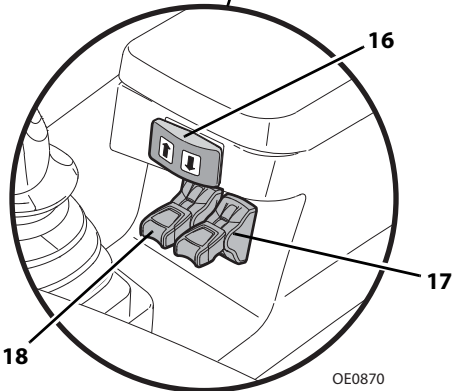

OE0870

Section 3- Controls and Indicators

1. **Transmission Control Lever (if equipped):** See page 3-18.
2. **Instrument Panel:** See page 3-4.
3. **Steering Wheel:** Turning the steering wheel to the left or right steers the machine in the corresponding direction. Three steering modes are available. See "Steer Modes" on page 3-34.
4. **Horn:** Press to sound horn.
5. **Frame Level Indicator:** Enables operator to determine the left to right level condition of the telehandler.
6. **Charts/Display:**
 - a. Capacity and Maintenance Charts (if equipped): See Section 5- Attachments and Hitches or Section 7- Lubrication and Maintenance.
 - b. Multifunction Display (if equipped): See page 3-29.
7. **Accessory Control lever (if equipped):** See page 3-20.
8. **Right Dash Control Panel:** See page 3-11.
9. **Joystick:** See page 3-22.
10. **Adjustable Armrest Lever (Agriculture):** Activate lever to release armrest position lock.
11. **Control Panel (Agriculture):** See page 3-13.
12. **Left Dash Control Panel:** See page 3-10.
13. **Service Brake Pedal:** Further pedal is pressed, the slower the travel speed.
14. **Ignition Switch:** Key activated. See page 3-4.
15. **Accelerator Pedal:** Pressing down the pedal increases engine and hydraulic speed.
16. **Hitch Up/Down Switch (if equipped):** Controls position of hydraulic hitch. Press and hold right side of switch to raise hitch. Press and hold left side of switch to lower hitch.
17. **Rear Auxiliary 1 Hydraulic Lever (if equipped):** Controls the rear auxiliary hydraulic.
18. **Rear Auxiliary 2 Hydraulic Lever (if equipped):** Controls the rear auxiliary hydraulic.
19. **Park Brake:** See page 3-17.
20. **Steering Column Adjuster:** See page 3-24.
21. **LSI Indicator:** See page 3-22.
22. **Agricultural Trailer Brake Switch (if equipped):** Push button switch to release the trailer park brake when pressed.

Section 3- Controls and Indicators

Instrument Panel

The instrument panel uses different colors to alert the operator to different types of operational situations that could arise.

- When an indicator illuminates RED (except park brake) or if a gauge enters a red zone, immediately bring machine to a stop, lower boom and attachment to the ground and stop the engine. Determine cause and correct before continued use.
- When an indicator illuminates YELLOW an abnormal operating condition is present. If not corrected, machine interruption or damage may result.
- When an indicator illuminates GREEN or BLUE or if a gauge is in the green zone, important information regarding safe operation is being displayed.

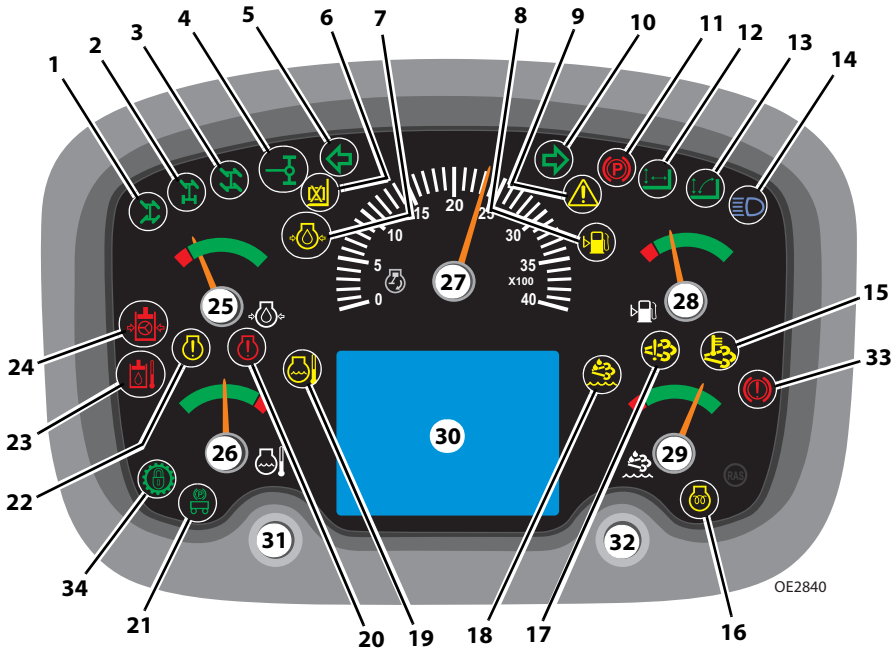

NOTICE

EQUIPMENT DAMAGE. When a red indicator illuminates (except park brake), immediately bring machine to a stop, lower boom and attachment to ground and stop the engine. Determine cause and correct before continued use.

1. **4-Wheel Circle Steer:** Illuminates when all wheel steer is active. See page 3-34.
2. **2-Wheel Front Steer:** Illuminates when two wheel steer is active. See page 3-34.
3. **4-Wheel Crab Steer:** Illuminates when crab steer is active. See page 3-34.

Section 3- Controls and Indicators

4. **Rear Axle Center:** Illuminates when rear axle is aligned (centered).
5. **Left Turn (if equipped):** Illuminates and flashes when left turn signal or hazard lights are active.
6. **LSI Passive Mode:** Illuminates when LSI passive mode is active. See page 3-22.
7. **Low Engine Oil Pressure:** Illuminates when oil pressure is low.
8. **Low Fuel Level:** Illuminates when fuel level is low.
9. **System Distress:** Illuminates when critical machine and engine faults exist.
10. **Right Turn (if equipped):** Illuminates and flashes when right turn signal or hazard lights are active.
11. **Park Brake:** Illuminates when park brake is applied. See page 3-17.
12. **Lift Mode:** Illuminates when lift joystick pattern is active. See page 3-10.
13. **Loader Mode:** Illuminates when loader joystick pattern is active. See page 3-10.
14. **High Beam (if equipped):** Illuminates when high beam lights are active.
15. **High Exhaust System Temperature (HEST) (SN TD200150 to Present, SN TA200150 to Present, SN TD600150 to Present, SN TH900150 to Present, SN TH200150 to Present, SN T7F00150 to Present):** May illuminate during exhaust system cleaning. See page 4-8.
16. **Engine Preheat:** Illuminates with ignition key in position 1. Indicator goes out when start temperature is reached.
17. **Selective Catalytic Reduction (SCR) (SN TD200150 to Present, SN TA200150 to Present):** Illuminates when stationary cleaning is required. Flashes during cleaning process. See page 4-8 for details.
Emissions System (SN TD600150 to Present, SN TH900150 to Present, SN TH200150 to Present, SN T7F00150 to Present): Illuminates when an issue exists with the emissions system.
18. **Low Diesel Emission Fluid (DEF) (SN TD200150 to Present, SN TA200150 to Present, SN TD600150 to Present, SN TH900150 to Present, SN TH200150 to Present, SN T7F00150 to Present):** Illuminates when DEF is low.
19. **High Engine Temperature:** Illuminates when engine temperature is high.
20. **Engine Fault Critical:** Illuminates when critical engine fault exists.
21. **Trailer Park Brake:** Illuminates when trailer park brake is activated.
22. **Engine Fault Warning:** Illuminates when engine is operating outside normal range.
23. **High Hydraulic Oil Temperature:** Illuminates when hydraulic oil temperature is high.
24. **Low Steering Pressure:** Illuminates when steering pressure is low.
25. **Engine Oil Pressure Gauge:** Indicates engine oil pressure.
26. **Engine Coolant Temperature Gauge:** Indicates engine coolant temperature.

Section 3- Controls and Indicators

- 27. Engine Speed:** Indicates engine speed in revolutions per minute (rpm). When maximum engine speed is exceeded, overspeed alarm will sound, a fault code will appear in the LCD display and machine speed will flash. See "LCD Display" on page 3-8.

NOTICE

EQUIPMENT DAMAGE. Operating machine with overspeed alarm sounding could result in engine or driveline damage.

- 28. Fuel Level Gauge:** Indicates fuel level.
- 29. Diesel Emission Fluid (DEF) Level Gauge (SN TD200150 to Present, SN TA200150 to Present, SN TD600150 to Present, SN TH900150 to Present, SN TH200150 to Present, SN T7F00150 to Present):** Indicates fluid level.
- 30. LCD Display:** See page 3-8.
- 31. Left Control Button:** Press to decrease display brightness. Increases digits in anti-theft function. See page 3-33.
- 32. Right Control Button:** Press to increase display brightness. Confirms digits in anti-theft function. See page 3-33.
- 33. Service Brake Fault:** Illuminates when service brake oil level or pressure is low.
- 34. Lock Up Clutch (if equipped):** Illuminates when lock up clutch feature is engaged. See page 3-14.

This Page Intentionally Left Blank

Section 3- Controls and Indicators

LCD Display

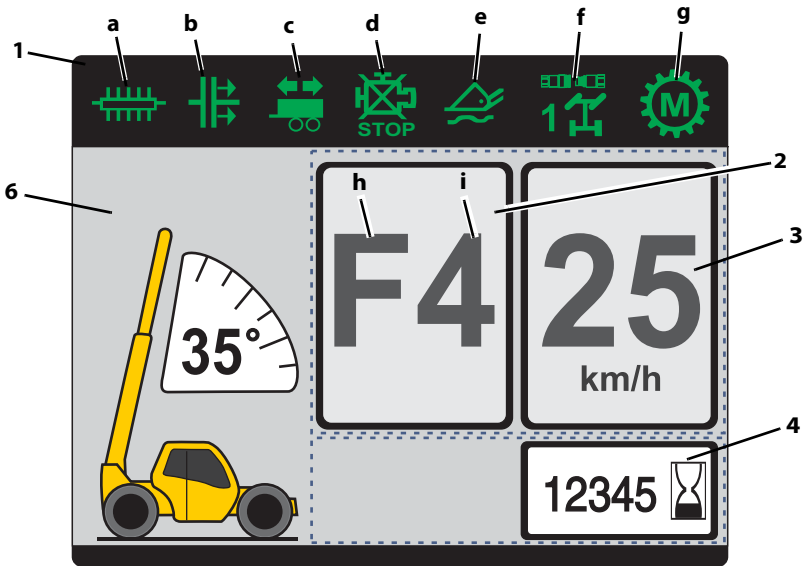

OE0431

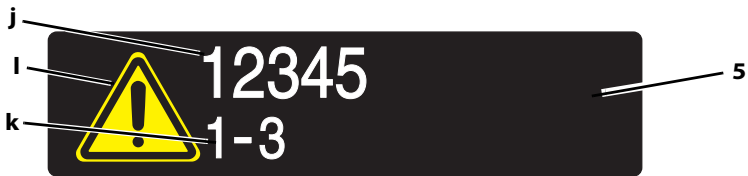

OD1480

VIEW WITH ACTIVE DIAGNOSTICS SHOWN

1. **Indicators:** Indicator will display when active.

- Continuous Auxiliary Hydraulics - Illuminates when continuous auxiliary hydraulics are active.
- Transmission Declutch - Illuminates when transmission declutch function is enabled. See page 3-13.
- Trailer Turn - Illuminates when trailer turn signal is activated.
- Do Not Shut Off Engine - Illuminates when stationary exhaust system cleaning is required. See page 4-8.
- Boom Float - Illuminates when boom float function is activated. See page 3-22.
- Auxiliary Hydraulic Selection - Illuminates when auxiliary hydraulics are activated. Indicator will show 1 or 2 depending on operator's selection. See page 3-31.
- Transmission Mode - Illuminates to display either Automatic or Manual mode. See page 3-14.

- 2. Driving Direction and Gear:** Displays current driving condition.
- h. Direction - Forward (F), Neutral (N) or Reverse (R).
 - i. Gear - First (1), Second (2), Third (3), Fourth (4), Fifth (5) or Sixth (6).
- 3. Speed (if equipped):** Displays machine speed km/h (mph). When maximum travel speed is exceeded, speed will flash and buzzer will sound.
- 4. Operating Hours:** Displays total hours of telehandler operation. Displays when ignition is in ON position and no fault codes exist.
- 5. Active Diagnostics:** Displays icon and applicable diagnostic code. Display cycles through each active warning or diagnostic if multiple are present. See Service Manual for details.
- j. Fault Code - Displays applicable diagnostic code.
 - k. Numeric Code Indicator - Displays number of engine fault codes which are present.



TRANSMISSION OIL TEMPERATURE



AIR CLEANER RESTRICTION INDICATOR



LOW BATTERY INDICATOR



SYSTEM DISTRESS INDICATOR



MAINTENANCE REQUIRED INDICATOR



OD0302
HYDRAULIC FILTER RESTRICTION INDICATOR

- l. Diagnostic Icon - Displays diagnostic symbols.
 - Transmission Oil Temperature Indicator - Illuminates when transmission temperature is high.
 - Air Cleaner Restriction Indicator - Illuminates when air cleaner requires maintenance.
 - Low Battery Indicator - Illuminates when battery is at low charge or charging system is not functioning properly.
 - System Distress Indicator - Illuminates when critical machine and engine faults exist.
 - Maintenance Required Indicator - Illuminates when maintenance is required.
 - Hydraulic Filter Restriction Indicator - Illuminates when hydraulic filter requires maintenance.

- 6. Boom Angle:** Displays boom angle.

Section 3- Controls and Indicators

Left Dash Control Panel

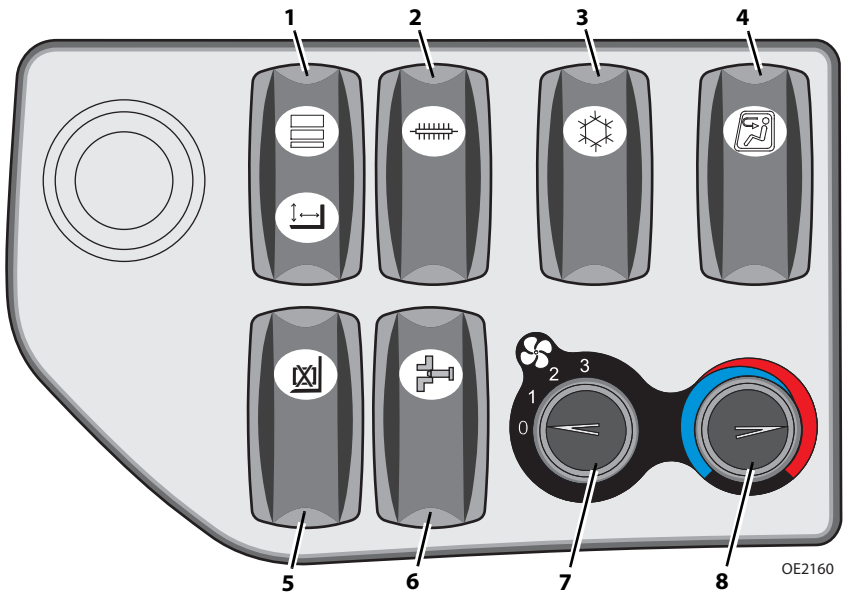

- 1. Lift/Loader Switch (if equipped):** Activates lift or loader pattern on joystick. See page 3-26. Press top of switch to activate loader joystick pattern. Press bottom of switch to activate lift joystick pattern. Lock at top of switch holds switch in its current position. Press and shift bottom of lock down to unlock. Release to lock switch into selected position.
- 2. Continuous Auxiliary Hydraulic Switch (if equipped):** Push for continuous operation of hydraulic powered attachments. To enable, press and hold while simultaneously pressing auxiliary hydraulic roller switch to desired command and speed on joystick. Release both switches to enable continuous operation of attachment. To disable, press continuous auxiliary hydraulics switch again. See Section 5- Attachments and Hitches for approved attachments and control instructions.
- 3. Air Conditioning Switch (if equipped):** On/Off switch.
- 4. HVAC Recirculation Switch (if equipped):** On/Off switch. Push to activate and recirculate air inside the cab. While deactivated, air is circulated from outside the cab.
- 5. LSI Override:** Momentarily disables the automatic function cut-out. Depress and hold up to 30 seconds while operating joystick to momentarily disable the automatic function cut-out.
- 6. Coupler Switch (if equipped):** Used in conjunction with joystick to hydraulically lock or unlock an attachment with boom angle below 20°. See page 5-13 for details.
- 7. HVAC Fan Speed (if equipped):** Adjustable rotary switch.
- 8. HVAC Temperature Control Switch (if equipped):** Adjustable rotary switch.

Right Dash Control Panel

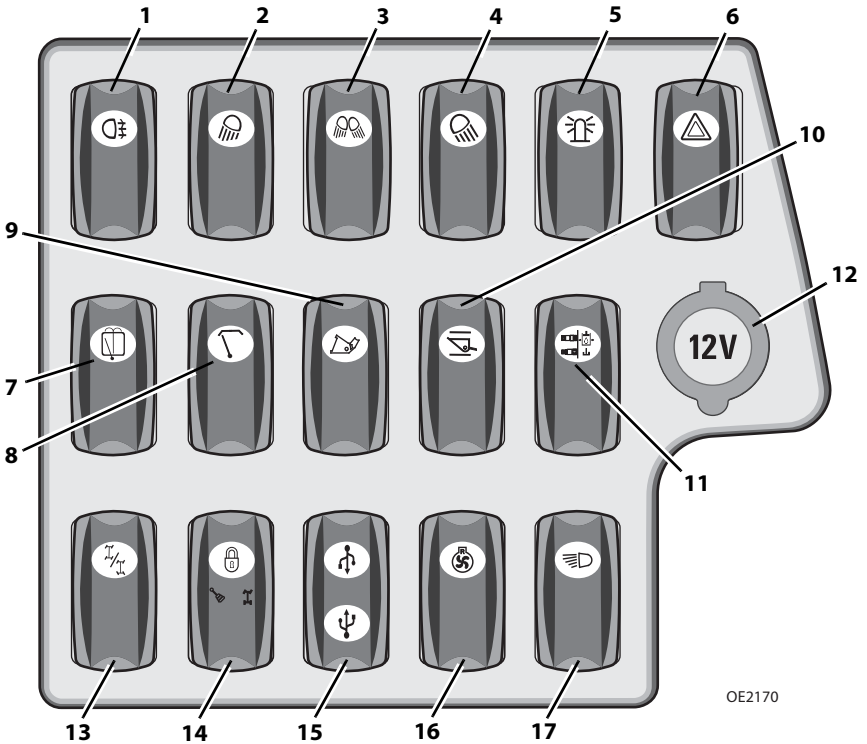

1. **Fog Lights Switch (if equipped):** On/Off switch.
2. **Front Work Lights Switch (if equipped):** On/Off switch.
3. **Boom Work Lights Switch (if equipped):** On/Off switch.
4. **Rear Work Lights Switch (if equipped):** On/Off switch.
5. **Beacon Light Switch (if equipped):** On/Off switch.
6. **Hazard Lights Switch (if equipped):** On/Off switch.
7. **Rear Wiper Switch (if equipped):** On/Off switch.
8. **Roof Wiper Switch (if equipped):** On/Off switch.
9. **Bucket Mode Switch:** On/Off switch. Increases response to boom functions.
10. **Boom Ride Control Switch (if equipped):** On/Off switch. While enabled and travelling 5 kph (3 mph) or faster, the system acts to improve boom control over rough terrain. Depress switch again to disable boom ride control.
11. **Auxiliary Decompression Switch (if equipped):** Press to relieve pressure in auxiliary hydraulic circuit. See page 5-14.

Section 3- Controls and Indicators

- 12. Power Outlet (if equipped):** 12V receptacle.
- 13. Steer Select Switch:** Three positions: circle steer, front steer and crab steer. See page 3-34.
- 14. Road Use (if equipped):** Joystick lock switch. See page 4-16.
- 15. USB Port (if equipped):** USB ports under protective tab.
- 16. Reversing Fan Switch (if equipped):** Three position switch. See page 3-21.
- 17. Master Light and Road Lights Switch:** Three positions: Off, Enable, On. Switch must be in the enable or on position in order to operate work lights. Prior to machine shut-down, ensure switch is in the off position.

This Page Intentionally Left Blank

Section 3- Controls and Indicators

Agriculture Control Panel (if equipped)

HYDROSTATIC TRANSMISSION

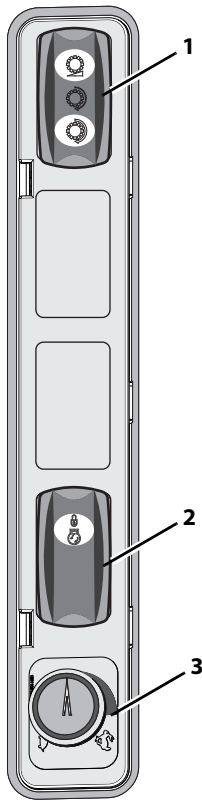

POWERSHIFT TRANSMISSION

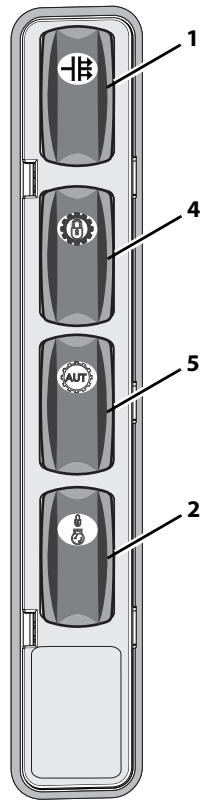

1. Travel Mode Switch (if equipped with hydrostatic transmission): Three positions: Proportional, Standard and Dynamic Travel modes. Adjusts hydrostatic transmission performance based on selected travel mode.

- Proportional: Vehicle ground speed is limited, independent of engine rpm, between 0% and 100% based on position of the proportional speed control switch (3).
- Standard: Vehicle drive system uses progressive ramp rates, giving smooth acceleration and deceleration rates.
- Dynamic: Vehicle drive system uses aggressive ramp rates, giving most responsive acceleration and deceleration rates.

Section 3- Controls and Indicators

Transmission Declutch Switch (if equipped with powershift transmission):

On/Off switch. While applying service brake, depress switch to enable transmission declutch function and disengage transmission. While applying service brake, depress switch to disable transmission declutch function and engage transmission.

- 2. Engine Speed Set Switch (if equipped):** On/Off switch. Once operator has desired engine speed (rpm) using accelerator pedal, press and release to set speed. Press service brake pedal to disable engine speed set.
- 3. Proportional Speed Control Switch (if equipped):** Adjustable rotary switch. Used when Travel Mode Switch (1) is in Proportional Travel mode. Increases or decreases engine speed.
- 4. Lock Up Clutch Switch (if equipped):** On/Off switch. Provides better fuel economy and trailer towing capability.
- 5. Automatic/Manual Shift Switch (if equipped with Lock Up Clutch):** On/Off switch. Press to allow automatic shifting in upper four gears for operator convenience while traveling at high speeds.

Section 3- Controls and Indicators

Ignition

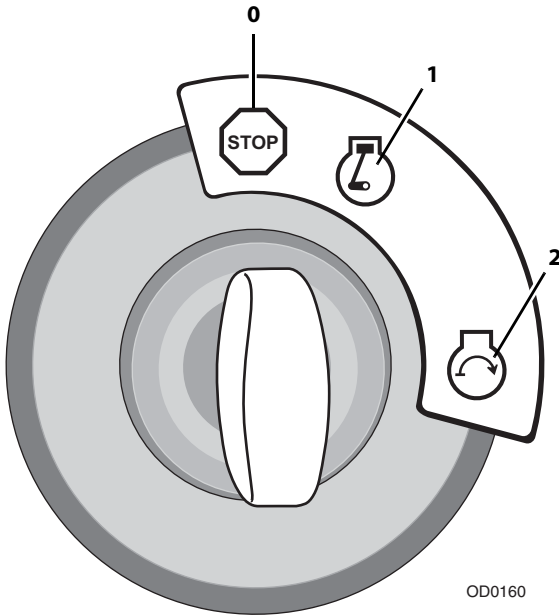

OD0160

- Position **0** - Engine off, no voltage available.
- Position **1** - Voltage available for all electrical functions. Wait to start engine until preheat indicator on instrument panel goes out.
- Position **1** - Engine run.
- Position **2** - Engine start. In the event the engine does not start, rotate key to position 0 then back to position 2 to re-engage the starter.

Park Brake

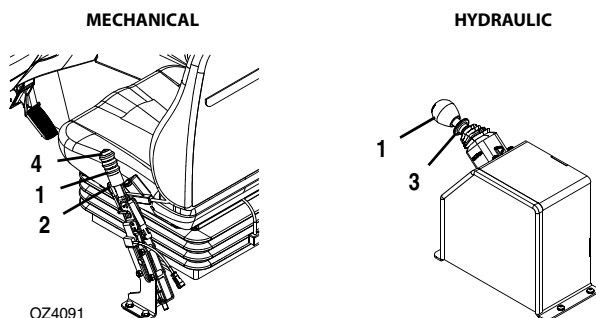

The park brake lever (1) controls the application and release of the park brake.

- Pull lever back to apply park brake.
- **MECHANICAL** - Squeeze release (2) and push lever forward to release park brake.
HYDRAULIC - Lift detent ring (3) and push lever forward to release park brake.
- **MECHANICAL** - The park brake may be adjusted with the knob (4). Turn clockwise to increase park brake force. Turn counterclockwise to decrease park brake force.



WARNING

MACHINE ROLL-AWAY HAZARD. In the event of engine failure, apply constant pressure to service brake pedal while activating the park brake to the ON position.



WARNING

MACHINE ROLL-AWAY HAZARD. Always move park brake switch to ON position, lower boom to ground and stop engine before leaving cab.



WARNING

CRUSH HAZARD. Turning engine off applies the park brake. Applying park brake or turning engine off while traveling will cause unit to stop abruptly and could cause load loss. Either may be used in an emergency situation.

Parking Procedure

1. Using service brake, stop telehandler in an appropriate parking area.
2. Follow "Shut-Down Procedure" on page 4-6.

Section 3- Controls and Indicators

Transmission Control Lever (if equipped)

Note: Transmission control lever takes priority over joystick transmission controls.

Direction of Travel Selection

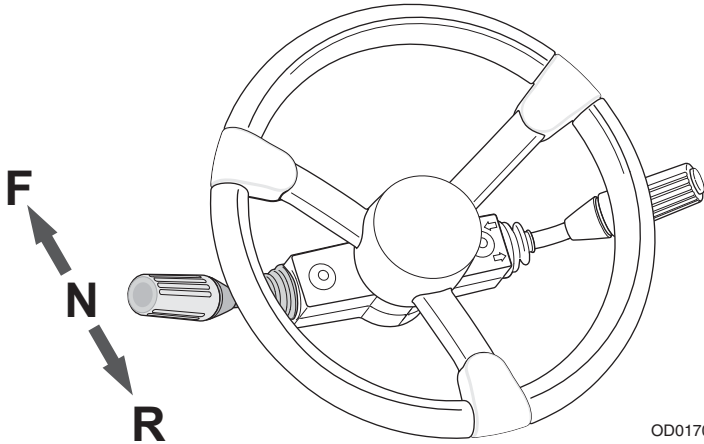

Transmission control lever engages forward or reverse travel.

- Push lever forward for forward travel; pull lever rearward for reverse travel. Move lever to centered position for neutral.
- Forward or reverse travel can be selected while in any gear.
- When traveling in reverse, the back-up alarm will automatically sound.
- Drive in reverse and turn only at slow rates of speed.
- Unless transmission declutch switch is activated, do not increase engine speed with the transmission in forward or reverse and the service brake pressed in an attempt to get quicker hydraulic performances. This could cause unexpected machine movement.



WARNING

TIP OVER/CRUSH HAZARD. Bring telehandler to a complete stop before shifting transmission control lever. A sudden change in direction of travel could reduce stability and/or cause load to shift or fall.

Gear Selection (if equipped)

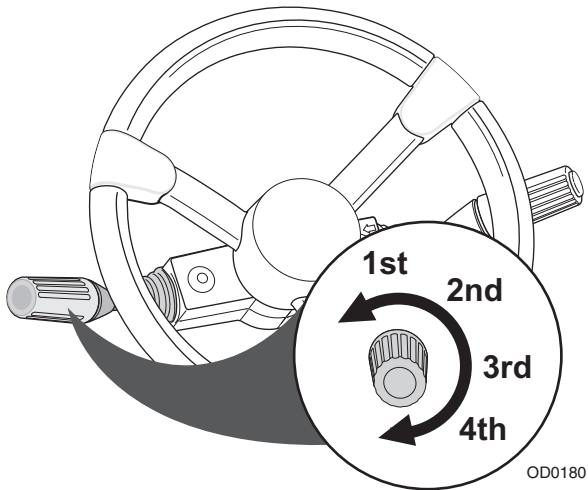

Gear selection is located on the twist grip handle of transmission control lever.

- Twist hand grip to select gear.
- The Transmission is equipped with either six forward and three reverse gears or four forward and three reverse gears
- Select appropriate gear for task being performed. **Use a lower gear for transporting a load.** Use a higher gear only when driving unloaded for longer distances.
- Slow down prior to downshifting. **Do not downshift more than one gear at a time.**

Section 3- Controls and Indicators

Accessory Control Lever (if equipped)

Turn Signals and Low/High Beam Headlights

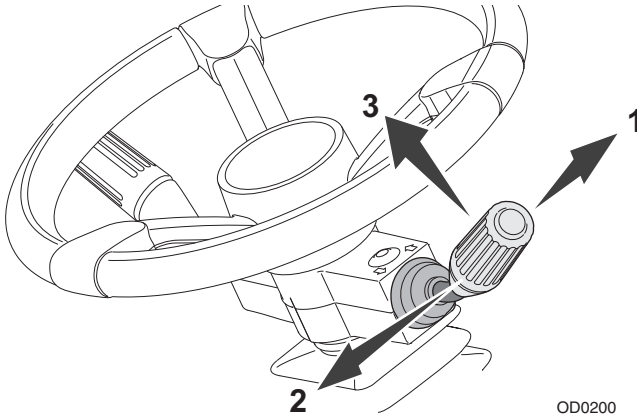

OD0200

- Push accessory control lever forward (1) to activate left turn signal.
- Pull lever backward (2) to activate right turn signal.
- The lever must be manually returned to the center position to deactivate either turn signal. The lever will not cancel automatically after a turn.
- Pull lever up (3) to switch between low and high beam headlights.

Front Windshield Wiper

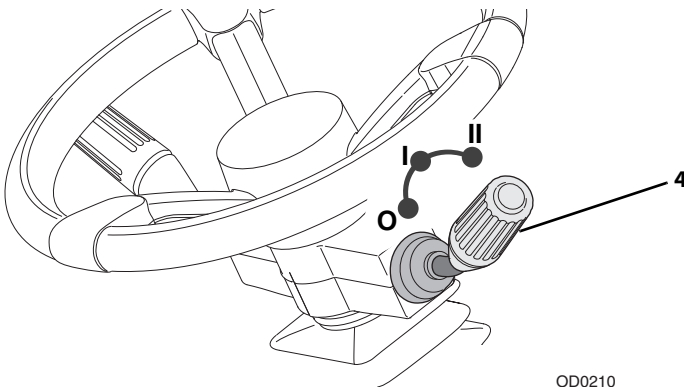

OD0210

- Rotate hand grip (4) to activate front windshield wiper.
O - Off, I - Continuous or II - Fast.
- Push hand grip (4) towards column to activate windshield wiper fluid.

Reversing Fan Switch (if equipped)

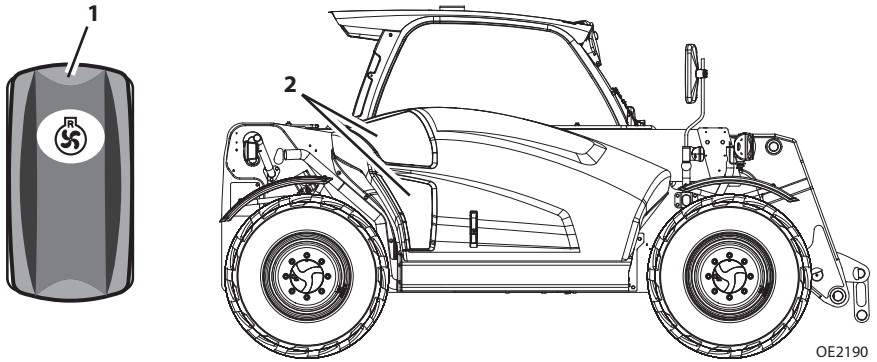

The reversing fan enables the operator to clear debris from the engine cover grill (2). Two modes of operation are available at any engine speed.

1. **Timed** - Fan will reverse automatically at predetermined intervals.
 - a. The fan will reverse every 20 minutes for a duration of 2 seconds.
 - b. The interval and duration can be adjusted using the analyzer.
2. **Manual** - The operator can depress and hold front of switch (1) to reverse the fan rotation.

Note: It is recommended to operate the reversing fan prior to opening the engine cover to remove debris.

Section 3- Controls and Indicators

Load Stability Indicator - LSI



WARNING

TIP OVER HAZARD. The LSI considers only longitudinal stability limitations, observe all operating parameters. Failure to follow operating parameters of the telehandler could damage the equipment and/or cause tip over.

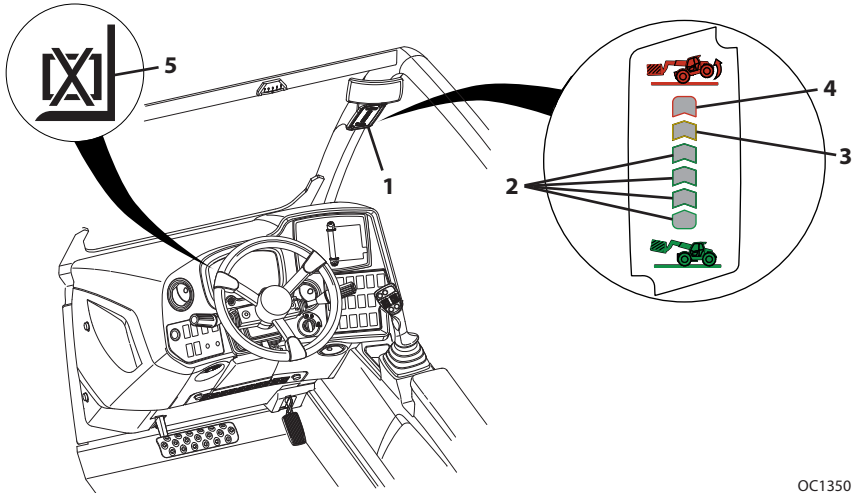

OC1350

The LSI (1) provides visual and audible indication of forward stability limitations when machine is static on firm, level surface.

- When approaching forward stability limitations LEDs progressively illuminate, green (2), then orange (3) and finally red (4).
- If the red LED illuminates the warning buzzer also sounds.

The LSI has two modes:

Active Mode

- As the telehandler reaches forward stability limitations and the red LED (4) illuminates, the automatic function cut-out is activated. All boom functions are disabled except for boom retract and boom lift (CE) and boom retract, boom lift and boom lower (AUS). Retract boom to re-enable functions.

Note: When functions are cut-out, the LSI Override Switch can be used to temporarily re-enable them. See "Left Dash Control Panel" on page 3-10.

- In some instances the LSI system may slow down or stop boom functions if operated close to forward stability limitations.

Passive Mode

- The yellow LED (5) on the instrument panel illuminates when either of the following occurs:

CE

- The boom is fully retracted.
- The park brake is not applied and transmission is in forward or reverse.

AUS

- The boom is fully retracted.
- The boom angle is below 10 degrees.
- When approaching forward stability limitations, visual and audible indication is provided and the automatic function cut-out and/or slow down feature is disabled.
- Travel in accordance with the requirements set forth in Section 1- General Safety Practices.
- When placing a load, ensure axles are not fully steered in either direction.



WARNING

TIP OVER HAZARD. If the green, orange and red LEDs flash and warning buzzer sounds, retract and lower boom immediately. Determine cause and correct before continued use.

Section 3- Controls and Indicators

Steering Column Adjuster

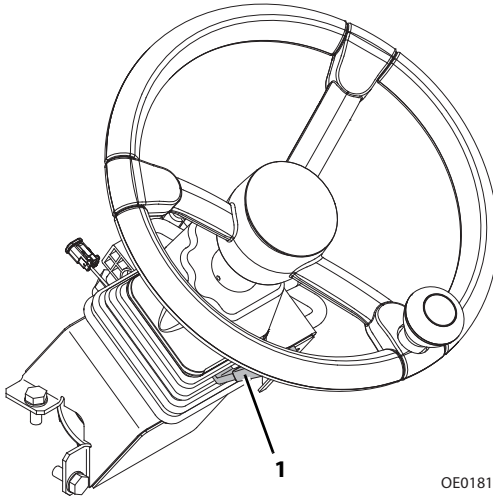

OE0181

- Follow “*Shut-Down Procedure*” on page 4-6.
- Pull and hold lever (1) to unlock.
- Place steering column in desired position.
- Release lever to lock back into place.



WARNING

TIP OVER/CRUSH HAZARD. Bring telehandler to a complete stop and shutdown engine before adjusting steering column. A sudden change in direction of travel could reduce stability and/or cause load to shift or fall.

This Page Intentionally Left Blank

Section 3- Controls and Indicators

Joystick

Lift Joystick Pattern

Verify the lift joystick pattern icon is active on the display.

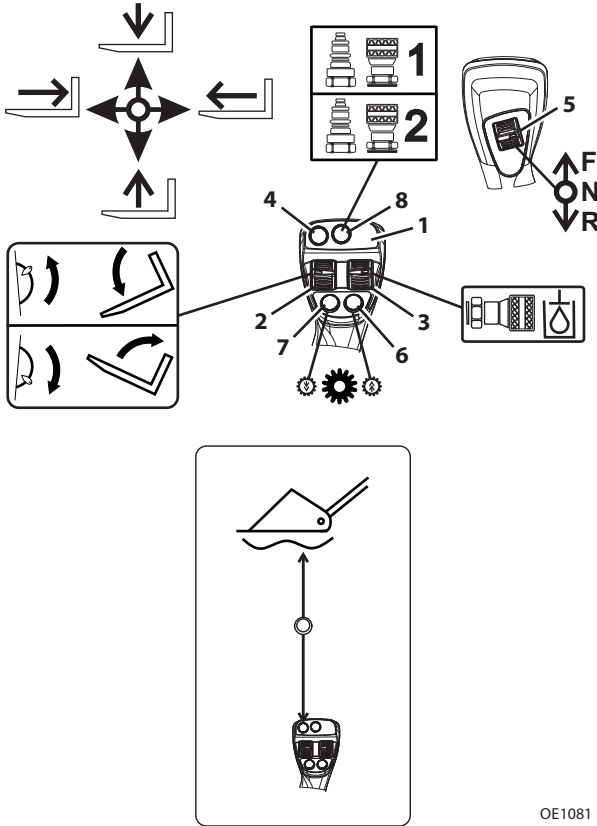

OE1081

The joystick (1) controls the boom, attachment, auxiliary hydraulics and transmission functions.

Boom Functions

- Move the joystick back to lift boom; move joystick forward to lower boom; move joystick right to extend boom; move joystick left to retract boom.
- The speed of boom functions depends upon the amount of joystick travel in corresponding direction. Increasing engine speed will also increase function speed.
- For two simultaneous boom functions, move joystick between quadrants. For example; moving the joystick forward and to the left will lower and retract boom simultaneously.



WARNING

TIP OVER/CRUSH HAZARD. Rapid, jerky operation of controls will cause rapid, jerky movement of the load. Such movements could cause the load to shift or fall or could cause the machine to tip over.

Attachment Tilt Function

Attachment tilt is controlled by the roller switch (2).

- Push the roller switch up to tilt attachment down; press the roller switch down to tilt attachment up.

Auxiliary Hydraulic Functions (if equipped)

The Auxiliary Hydraulics roller switch (3) controls the function of attachments that require the hydraulic supply for operation. See Section 5- Attachments and Hitches for approved attachments and control instructions.

The Auxiliary Hydraulic selection switch (8) allows the desired auxiliary hydraulic function to be selected. Depress button to alternate between functions.

Boom Float Functions (if equipped)

Joystick button (4) controls boom float. Boom float allows free movement of boom (lift/lower) while the attachment follows ground contours.

- With the boom retracted and lowered, press and hold the button; move the joystick forward to activate boom float. Button and joystick position must be held to maintain boom float.
- Release button to deactivate boom float and move joystick to neutral position.

Section 3- Controls and Indicators

Transmission Control (if equipped)

Note: Transmission control lever (see page 3-18) takes priority over joystick transmission controls.

Transmission roller switch (5) engages forward or reverse travel.

- Push the roller switch up for forward travel; push the roller switch down for reverse travel. Move roller switch to centered position for neutral.
- Forward or reverse travel can be selected while in any gear.
- When traveling in reverse, the back-up alarm will automatically sound.
- Travel at slow rates of speed when making turns and driving in reverse.



WARNING

TIP OVER/CRUSH HAZARD. Bring telehandler to a complete stop before shifting transmission. A sudden change in direction of travel could reduce stability and/or cause load to shift or fall.

Gear selection is controlled by buttons (6 & 7).

- Depress upshift button (6) to select a higher gear; Depress downshift button (7) to select a lower gear.
- The transmission is equipped with either six forward and three reverse gears or four forward and three reverse gears. Default gear at start-up is third gear.
- Select the appropriate gear for the task being performed. Use a lower gear when transporting a load. Use a higher gear only when driving unloaded for longer distances.
- Slow down prior to downshifting. Do not downshift more than one gear at a time.

This Page Intentionally Left Blank

Section 3- Controls and Indicators

Loader Joystick Pattern

Verify the loader joystick pattern icon is active on the display.

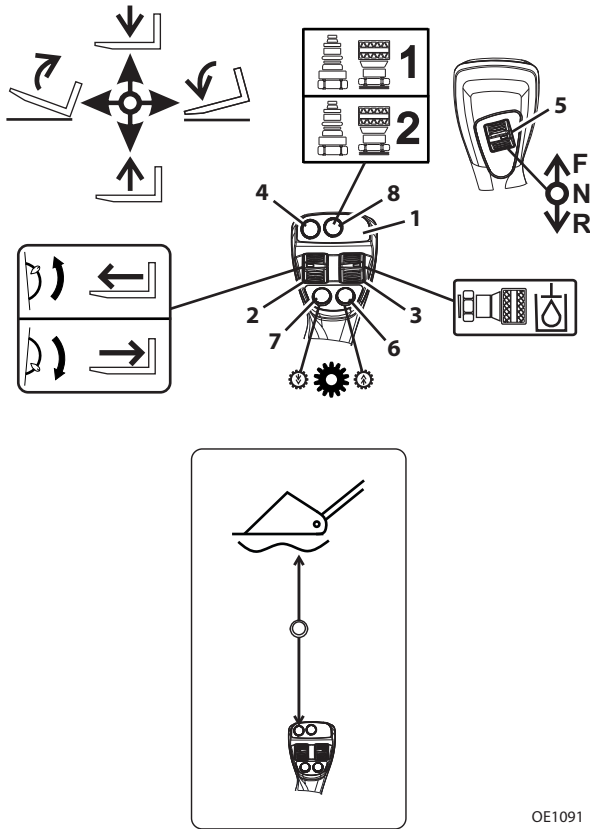

OE1091

The joystick (1) controls the boom, attachment, auxiliary hydraulics and transmission functions.

Boom Functions

- Move the joystick back to lift boom; move joystick forward to lower boom.
- The speed of boom functions depends upon the amount of joystick travel in corresponding direction. Increasing engine speed will also increase function speed.
- For two simultaneous boom functions, move joystick between quadrants. For example; moving the joystick forward and to the left will lower and retract boom simultaneously.



WARNING

TIP OVER/CRUSH HAZARD. Rapid, jerky operation of controls will cause rapid, jerky movement of the load. Such movements could cause the load to shift or fall or could cause the machine to tip over.

Attachment Tilt Function

Attachment tilt is controlled by the joystick.

- Move joystick right to tilt down; move joystick left to tilt up.

Auxiliary Hydraulic Functions (if equipped)

The Auxiliary Hydraulics roller switch (3) controls the function of attachments that require the hydraulic supply for operation. See Section 5- Attachments and Hitches for approved attachments and control instructions.

The Auxiliary Hydraulic selection switch (8) allows the desired auxiliary hydraulic function to be selected. Depress button to alternate between functions.

Boom Float Functions (if equipped)

Joystick button (4) controls boom float. Boom float allows free movement of boom (lift/lower) while the attachment follows ground contours.

- With the boom retracted and lowered, press and hold the button; move the joystick forward to activate boom float. Button and joystick position must be held to maintain boom float.
- Release button to deactivate boom float and move joystick to neutral position.

Section 3- Controls and Indicators

Transmission Control (if equipped)

Note: Transmission control lever (see page 3-18) takes priority over joystick transmission controls.

Transmission roller switch (5) engages forward or reverse travel.

- Push the roller switch up for forward travel; push the roller switch down for reverse travel. Move roller switch to centered position for neutral.
- Forward or reverse travel can be selected while in any gear.
- When traveling in reverse, the back-up alarm will automatically sound.
- Travel at slow rates of speed when making turns and driving in reverse.



WARNING

TIP OVER/CRUSH HAZARD. Bring telehandler to a complete stop before shifting transmission. A sudden change in direction of travel could reduce stability and/or cause load to shift or fall.

Gear selection is controlled by buttons (6 & 7).

- Depress upshift button (6) to select a higher gear; Depress downshift button (7) to select a lower gear.
- The transmission is equipped with either six forward and three reverse gears or four forward and three reverse gears. Default gear at start-up is third gear.
- Select the appropriate gear for the task being performed. Use a lower gear when transporting a load. Use a higher gear only when driving unloaded for longer distances.
- Slow down prior to downshifting. Do not downshift more than one gear at a time.

3.3 ANTI-THEFT FUNCTIONALITY (IF ENABLED)

Machines with anti-theft feature active require entering a numeric code before operation to prevent unauthorized use. If multifunction display is installed, anti-theft feature is accessed from that display only.

Note: If the anti-theft feature is active and the current access code is not known, it may be viewed or changed by the machine owner (level 2 password may be required). See Service Manual for information.

Instrument Panel Input

Code entry is accomplished using information provided in the instrument panel display.

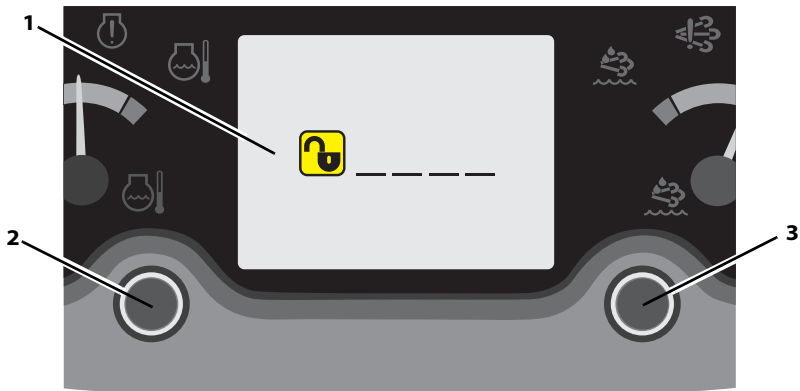

OD1240

1. Turn ignition switch to position 1. If anti-theft is active, the display (1) will prompt the operator for a numeric code.
2. Use the left button (2) to select the first digit. Press button to increase number. Number will increase from 0 thru 9 then roll over to 0.
3. Press the right button (3) to confirm current digit and move to the next digit.
4. Continue until the code is complete.
5. If an incorrect code is entered, the display will prompt the operator again for the numeric code.
6. If the correct code is entered, normal start up can continue.

Multifunction Display Input

If machine is equipped with Multifunction Display, refer to page 3-58 for anti-theft functionality information.

Section 3- Controls and Indicators

3.4 STEER MODES

Three steer modes are available for operator use.

2-Wheel Front Steer

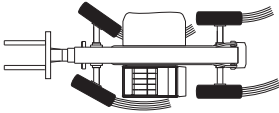

OAL2030

4-Wheel Circle Steer

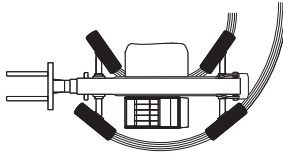

4-Wheel Crab Steer

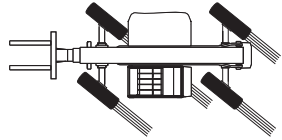

Note: 2-Wheel Front Steer mode is required for travel on public roads.

Manual Steering Alignment Mode Change

Note: Steer mode will change immediately after selection.

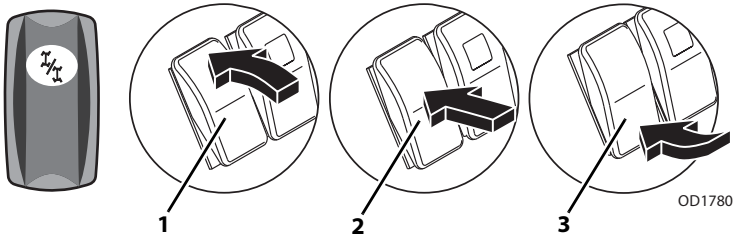

1. Bring machine to a stop using service brake. If front steer mode (2) is active and rear wheels are aligned, go directly to step 4.

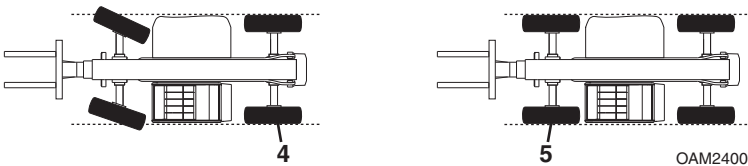

2. With circle steer (1) or crab steer (3) mode active, turn the steering wheel until the left rear wheel (4) is aligned with the side of the machine.
3. Select front steer mode (2).
4. Turn the steering wheel until the left front wheel (5) is aligned with the side of the machine.
5. Wheels are now aligned. Select desired steer mode.

All Wheel Assisted Steering Alignment Mode Change

1. Bring machine to a stop using service brake.

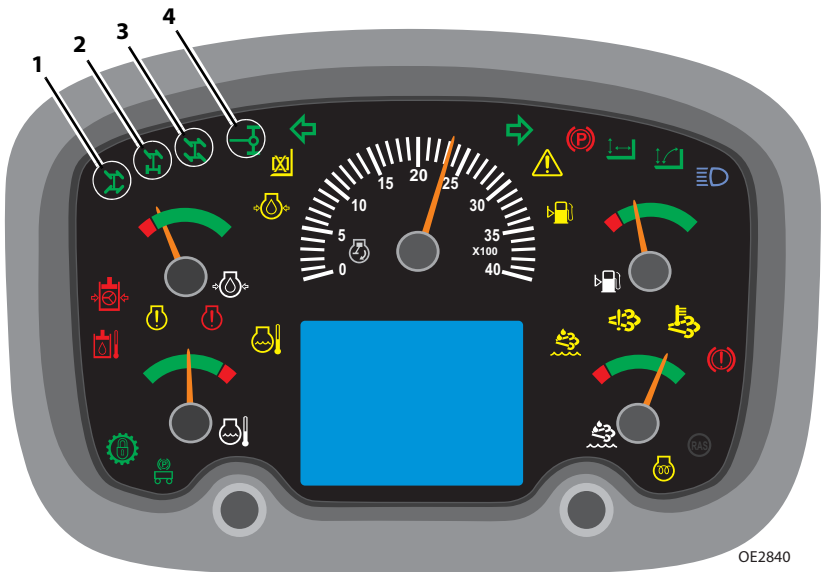
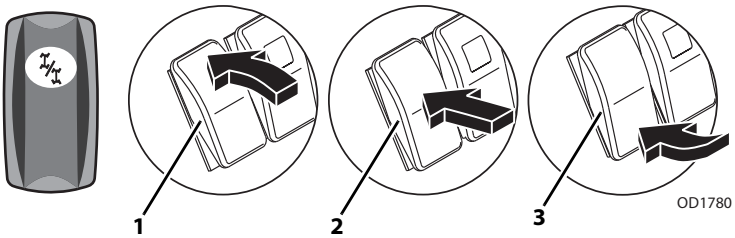

2. Select desired steer mode: circle steer (1), front steer (2) or crab steer (3).

Note: Selected steer mode LED will flash until the change is complete. After steering alignment is complete, steer mode LED will illuminate solid.

3. Turn the steering wheel slowly until the rear wheels are centered (4). This step will be skipped if changing from front steer mode and rear wheels are already centered.
4. Turn the steering wheel slowly until the front wheels are centered. This step will be skipped if changing to front steer mode.
5. Wheels are now aligned and steer mode change is complete.

Note: Avoid turning steering wheel while machine is shut down. If wheels are not correctly aligned, manual adjustment may be required. See page 3-34.

Section 3- Controls and Indicators

3.5 OPERATOR SEAT

Operator Presence

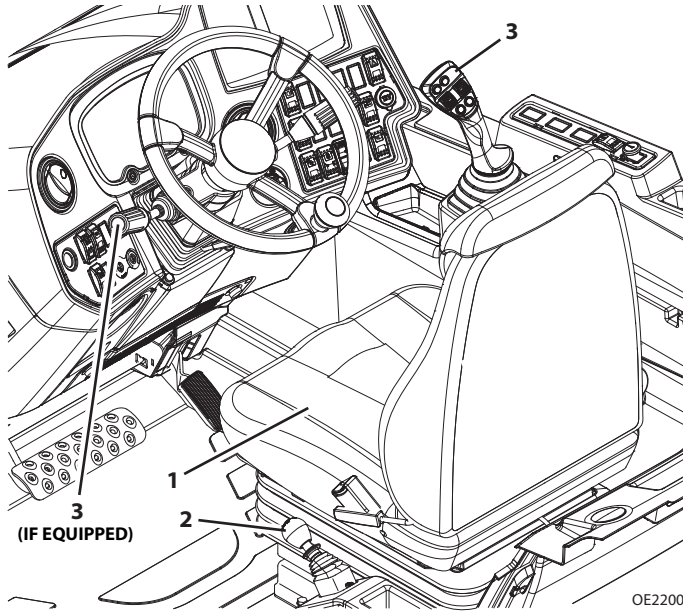

The operator seat (1) is equipped with an operator presence system. Engine start and hydraulic functions are prohibited if operator is not present. If the system detects a loss of pressure during operation, after a two second delay one of the following will occur:

1. With the park brake (2) engaged and transmission in neutral (3):
 - Hydraulic controls are disabled. (Continuous Auxiliary function permitted)
 - Upon returning to seated position, hydraulic controls are enabled.
2. With the park brake (2) disengaged and transmission in neutral (3):
 - Hydraulic controls are disabled and horn sounds continuously. (Continuous Auxiliary function permitted)
 - Upon returning to seated position, hydraulic controls are enabled and horn will cease.
3. With the park brake (2) disengaged and transmission in forward or reverse (3):
 - Hydraulic controls are disabled, horn sounds continuously and transmission shifts to neutral.
 - Upon returning to seated position, hydraulic controls are enabled and horn will cease. Return transmission to neutral to allow system to reset prior to reengaging forward or reverse travel.

Adjustments

Prior to starting the engine adjust seat for position and comfort.

Mechanical Suspension Seat

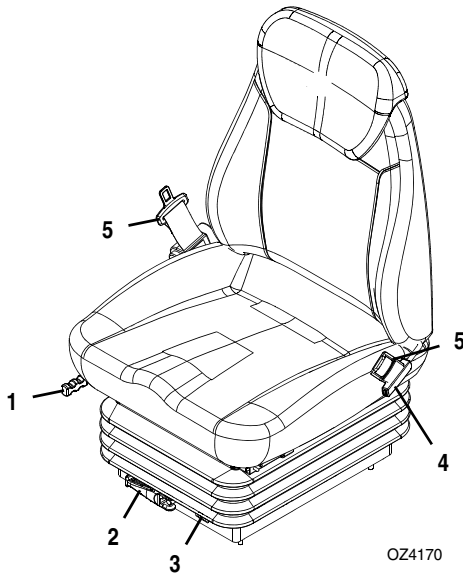

1. **Fore/Aft:** Use handle to move seat fore and aft.
2. **Suspension:** Use handle to adjust the suspension to the appropriate weight setting.
3. **Weight:** Displays current weight setting.
4. **Backrest:** Use lever to adjust backrest angle.
5. **Seat Belt:** Always fasten seat belt during operation. If required, a 76 mm (3 in) seat belt is available.

Section 3- Controls and Indicators

Pneumatic Suspension Seat

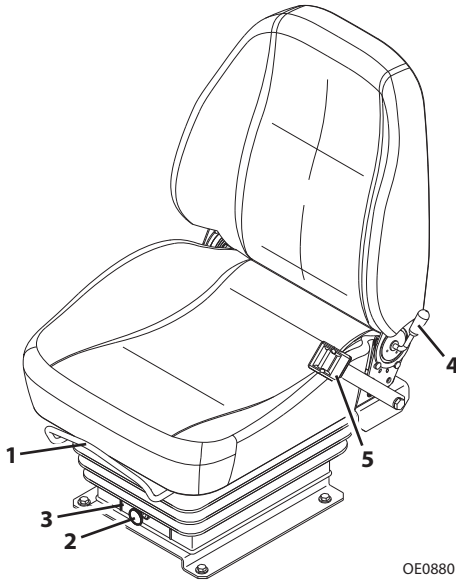

OE0880

1. **Fore/Aft:** Use handle to move seat fore and aft.
2. **Suspension:** Use knob to adjust the suspension to the appropriate weight setting.
3. **Weight:** Displays current weight setting.
4. **Backrest:** Use lever to adjust backrest angle.
5. **Seat Belt:** Always fasten seat belt during operation. If required, a 76 mm (3 in) seat belt is available.

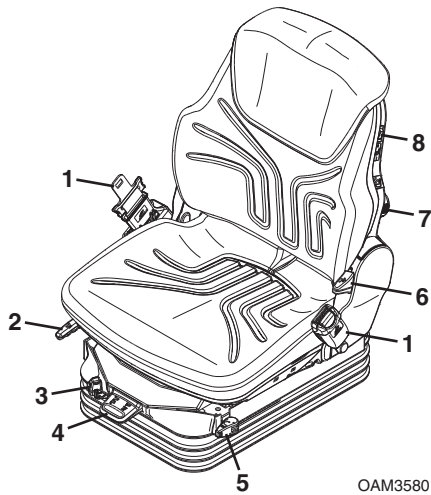

OAM3580

- 1. Seat Belt:** Always fasten seat belt during operation. If required, a 76 mm (3 in) seat belt is available.
- 2. Fore/Aft:** Use handle to move seat fore and aft.
- 3. Absorber:** Use lever to adjust cushioning to soft or hard.
- 4. Suspension:** Use the lever to adjust the suspension to the appropriate weight and height settings.
- 5. Fore/Aft Isolator:** Use lever to activate fore/aft isolator.
- 6. Backrest:** Use lever to adjust backrest angle.
- 7. Lumbar:** Use knob to adjust the height and curvature of the backrest cushion.
- 8. Heater:** Use switch to activate seat heater.

Section 3- Controls and Indicators

Seat Belt



Fasten seat belt as follows:

1. Grasp both free ends of the belt making certain that belt webbing is not twisted or entangled.
2. With back straight in the seat, couple the retractable end (male end) of the belt into the receptacle (buckle) end of the belt.
3. With belt buckle positioned as low on the body as possible, pull the retractable end of the belt away from the buckle until it is tight across the lap.
4. To release belt latch, press red button on the buckle and pull free end from buckle.

3.6 BOOM INDICATORS

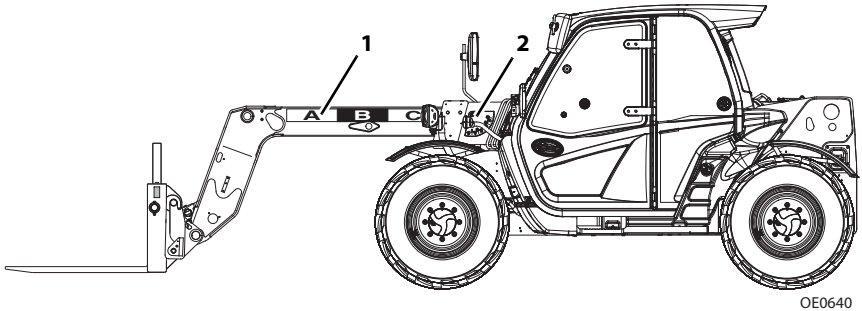

Boom Extension

- The boom extension indicators (1) are located on the left side of the boom. Use these indicators to determine boom extension when using the capacity chart (see *“Use of the Capacity Chart”* on page 5-6).

Boom Angle (if equipped)

- The boom angle indicator (2) is located on the left side of the boom. Use this indicator to determine boom angle when using the capacity chart (see *“Use of the Capacity Chart”* on page 5-6).

3.7 REVERSE SYSTEMS (IF EQUIPPED)



WARNING

CRUSH HAZARD. Running into persons or objects can cause death, serious injury, or damage to property and equipment. Always check mirrors and area behind vehicle before and when backing up. Reverse systems are for supplementary use only.

Reverse Sensing System

The reverse sensing system provides audible indication of objects to rear of unit while in reverse gear.

- Alarm sounds signaling machine is placed in reverse gear.

Note: *Reverse Sensing System detects objects larger than 232.25 square centimeters (36 square inches) area and is functional when machine is moving in reverse direction.*

- No alarm when detection zone is clear of objects.
- Pulsing alarm sounds when an object is in range of Reverse Sensing System. Alarm increases in frequency as object becomes closer.
- If alarm sounds at a frequency of eight pulses per second (8 Hz) an object is detected within 0.9 m (3 feet). Stop reverse direction of machine by applying service brake. Perform “*Shut-Down Procedure*” on page 4-6. Check and clear area behind machine of objects before proceeding in a reverse direction.

Reversing Camera (if equipped)

If machine is equipped with Multifunction Display, refer to page 3-63 for reversing camera information.

3.8 MULTIFUNCTION DISPLAY (IF EQUIPPED)

General Information

This section provides the necessary information needed to understand the multifunction display.

Start of Multifunction Display

The multifunction display will be active when the ignition is in position 1.



OAP0320

After the multifunction display has been powered on, the machine brand logo (1) will be displayed briefly followed by the home screen.

Note: If anti-theft is active, the display will prompt the operator for a numeric code. See page 3-58 for procedure.

Section 3- Controls and Indicators

Multifunction Display and Buttons

Note: Apply park brake to access the Attachment Selection and Main Menu buttons.



OAP0480

1. Display: The display shows the following depending on selection.

- Anti-theft. See page 3-58.
- Home screen. See page 3-46.
- Reversing camera (if equipped). See page 3-63.
- Advanced diagnostics. See page 3-50.
- Maintenance charts. See page 3-64.
- Lubrication charts. See page 3-66.
- Visibility charts. See page 3-74.
- Personalities screen: Personalities menu displays various electrically controlled parameters that drive the hydraulic functions related to outriggers, frame level, boom lift, extend/retract and auxiliary. See Service Manual for more personalities information.
- Operator tools screen. See page 3-55.
- Calibration screen. See page 3-56.

- 2. Previous Screen Button:** The previous screen button returns the display to the previous menu or screen. The screen will not change if already at the home screen.
- 3. Attachment Select Button:** The attachment selection button allows the operator to select a specific attachment in order to display the applicable capacity chart. See page 3-59.
- 4. Navigation Button:** The navigation button has four arrow buttons to navigate up, down, left or right. The center button allows the operator to confirm the selection.
- 5. Main Menu Button:** The main menu button displays the main menu. The operator can navigate the menu using the navigation button. See page 3-49.
- 6. Home Screen Button:** The home screen button returns display to the home screen. The screen will not change if already at the home screen.

Section 3- Controls and Indicators

Home Screen

The home screen displays at the successful startup or when the Home Screen button is selected.

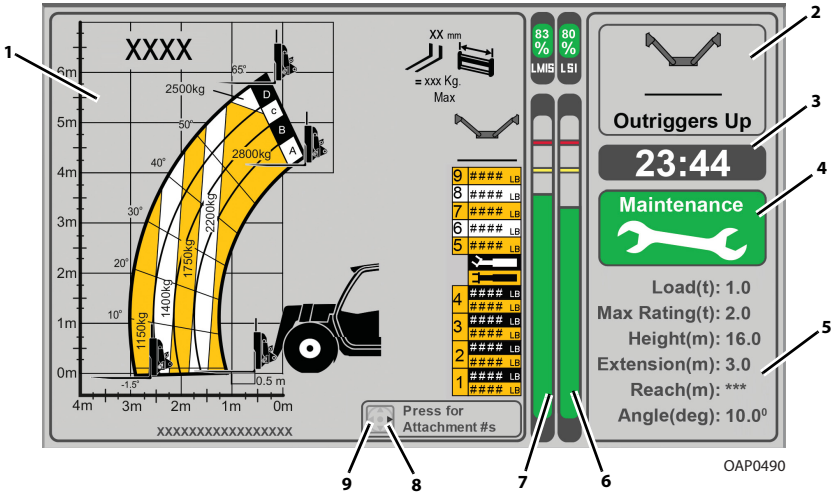

- 1. Capacity Chart:** The capacity chart is displayed based on the selected attachment, and if equipped, selected outriggers position. See page 3-59 for capacity chart selection and page 5-6 for use of the capacity chart.

Note: If the display does not have capacity charts, see Service Manual for troubleshooting.

- 2. Outriggers Position (if equipped):** Outriggers position displays the current outriggers position. Appropriate capacity chart will display based on the outriggers position. If machine is not equipped with pressure and proximity sensors, appropriate capacity chart will be manually selected based on outriggers position. See page 3-61.

Note: If machine is not equipped with outriggers, the outriggers position will be blank.

- 3. Real-Time Clock (RTC):** The real-time clock displays the time in 12 or 24 hour format.
- 4. Maintenance Status:** The maintenance status icon shows the current status of maintenance and notifies the operator if any maintenance activity is required. See page 3-53.

- Green: No scheduled maintenance required.
- Yellow: Scheduled maintenance required. See page 3-64.

Note: Brand logo is displayed when the maintenance status is not enabled.

- 5. Lifting Information (if equipped with LMIS):** The lifting information displays the load and boom position information.
- Load: Displays approximate load in metric ton or k-pounds. Load includes object being lifted and all rigging (slings, etc).
 - Maximum Rating/Rated Capacity: Displays rated capacity in metric ton or k-pounds.
 - Height: Displays boom height in meters or feet.
 - Length: Displays boom length in meters or feet.
 - Radius/Reach: Displays boom reach from front of tires in meters or feet.
 - Angle: Displays boom angle in degrees.
- 6. Load Stability Indicator (LSI) Bar Graph (if equipped with LMIS):** Load stability indicator system bar graph displays forward stability limitations when machine is static on firm, level surface. See *"Load Stability Indicator - LSI"* on page 3-22.
- Green: LSI bar graph displays in green color when forward stability limitations is less than 90%.
 - Yellow: LSI bar graph displays in yellow color when forward stability limitations is between 90% and 99%.
 - Red: LSI bar graph displays in red color when forward stability limitations is greater than 100%.
- 7. Load Management Indicator System (LMIS) Bar Graph (if equipped):** Load management indicator system bar graph displays approximate load percentage to rated capacity.
- Green: LMIS bar graph displays in green color when load is less than rated capacity.
 - Yellow: LMIS bar graph displays in yellow color when load is approaching rated capacity.
 - Red: LMIS bar graph displays in red color when automatic function cut-out is activated. Certain functions are disabled (i.e. boom lift, extend, etc). Retract boom to re-enable functions.

Section 3- Controls and Indicators

- 8. Attachment Part Numbers:** Press right Navigation button to display the list of OEM supplied attachment part numbers. Part numbers display for 3 seconds, then home screen displays.



OAP0500

- Additional Operating Information (AUS):** Press left Navigation button to display the travelling information, lifting information and specifications for safe use.



OAP0400

Main Menu

Press the Main Menu button to access the main menu.

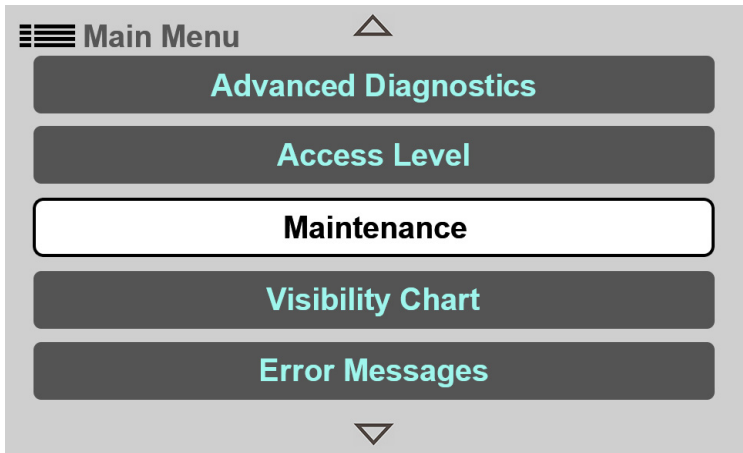

OAP0410

Note: Scroll up or down to view all items.

Maintenance

Maintenance menu displays the maintenance intervals and lubrication requirements to properly maintain the telehandler.

Maintenance Intervals: Maintenance intervals allow the operator to view all the unique maintenance tasks required when engine hours reach an identified interval or multiples of the intervals. See page 3-64.

Lubrication: Lubrication allows the operator to view lubrication charts. See page 3-66.

Access Level

The access level screen displays the current access level. Code entry determines access level.

- Operator (Level 3) - No code required.
- Customer (Level 2) - See Service Manual.
- Service (Level 1) - Manufacturer service representative only.

Section 3- Controls and Indicators

Advanced Diagnostics

Advanced diagnostics menu allows the operator to view diagnostic information.

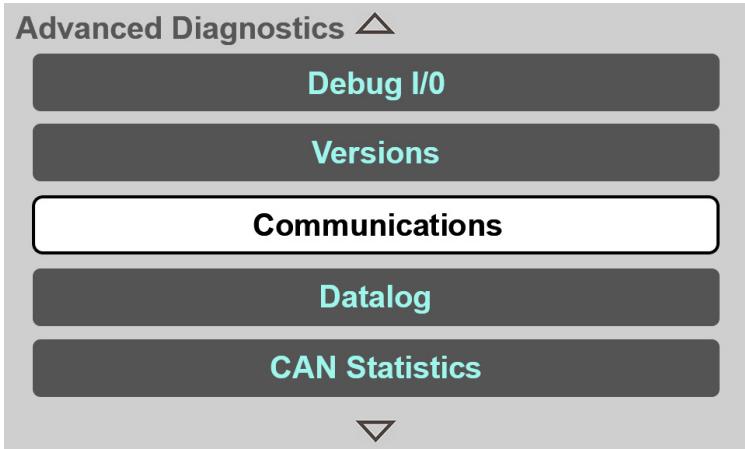

OAP0060

Communications: Communications screen displays the status of all CAN modules in the control system. The status of the appropriate module will be RED in color, if there is any CAN loss. If the communication is good, the appropriate module status will be GREEN in color.

Versions: Versions screen displays the version of the software, hardware and constant data of control modules in the machine.

Debug I/O: Debug I/O screen displays the status of all inputs/outputs and assigned machine function name for the cabin control module, front frame facing control module, and rear frame facing control modules.

Engine: Engine screen displays parameters related to engine.

Joystick: Joystick screen displays parameters related to the joystick.

Transmission: Transmission screen displays parameters related to the drive or transmission.

Hydraulics: Hydraulics screen displays parameters related to the outriggers, frame level and cabin functions.

Load Stability Indicator: Load stability indicator screen displays parameters related to Load stability indicator.

Calibration Data: Calibration data screen displays calibration values for all calibrated sensors in the control system.

System: System screen displays parameters related to control system.

Drive/Steer: Drive/Steer screen displays parameters related to steering system.

Lights: Lights screen displays parameters related to lighting.

Boom Ride & Float: Boom ride and float screen displays parameters related to boom ride and float.

CAN Statistics: CAN statistics screen displays the parameters of the system bus and diagnostic bus.

Section 3- Controls and Indicators

Display Settings

Display settings menu allows the operator to set up the Real-Time Clock (RTC) and screen brightness. Additionally, the operator can view the language settings, maintenance status icon (enable/disable) and revision number of library files.

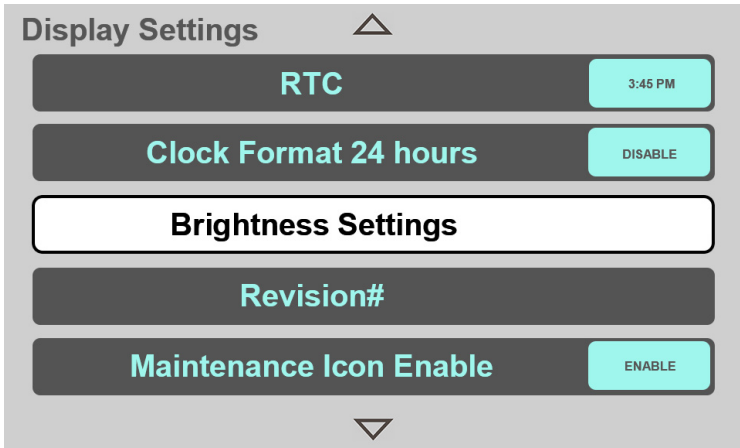

OAP0070

Brightness Settings: Brightness settings menu allows the operator to adjust the screen brightness. It consists of following features to adjust the screen brightness.

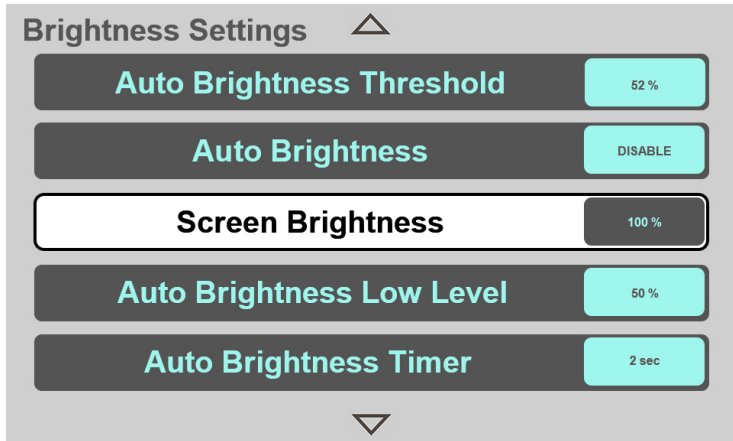

OAP0080

- Screen Brightness:** Screen brightness allows the operator to adjust the screen brightness (0 - 100% in 1% increment).
- Auto Brightness:** Auto brightness screen allows the operator to set auto brightness to enable or disable mode.

- c. **Auto Brightness Threshold:** Auto brightness threshold allows the operator to adjust the auto brightness threshold value when auto brightness is enabled. Based on ambient light level and auto brightness threshold, display will set to auto brightness low level or screen brightness.
- d. **Auto Brightness Timer:** Auto brightness timer allows the operator to adjust the length of time to change to appropriate brightness when auto brightness is enabled.
- e. **Auto Brightness Low Level:** Auto brightness low level allows the operator to set the preferred lowest brightness level (in %) when auto brightness is enabled.

Clock Format 24 Hours: Clock format screen allows the operator to set the real-time clock in 12 or 24 hour format.

Real-Time Clock (RTC): Real-time clock screen allows the operator to set hours, minutes, day, month and year by the use of navigation button.

Language: Language allows the operator to view the current language. See Service Manual to change current language.

Maintenance Icon Enable: Maintenance icon enable screen allows the operator to set the maintenance status to enable or disable mode on the home screen.

Revision#: Revision# screen displays the revision numbers of all libraries (including super library) and application.

Competitive Coupler: Competitive coupler screen allows the operator to show or hide competitive coupler attachments in the attachment selection menu when a competitive coupler is fitted.

Section 3- Controls and Indicators

Machine Set-Up

Machine set-up menu displays configuration (brand, model, engine and transmission etc.) of the machine.

The screenshot shows a 'Machine Set-up' menu with five items, each with a label and a corresponding value in a button:

- Model**: XXXXX
- Vehicle**: XXX-XX
- Brand**: CAT
- Options**: (no value shown)
- Market**: XX

The menu is titled 'Machine Set-up' at the top left and has an upward-pointing triangle at the top center and a downward-pointing triangle at the bottom center.

OAP0510

Brand: Brand displays brand name of the machine.

Vehicle: Vehicle displays the type of vehicle based on boom configuration and market preferences.

Model: Model displays machine model.

Options: Options screen provides machine configuration details for transmission, engine control, auxiliary functions and all other controls.

Market: Market displays applicable compliance standard.

Operator Tools

Operator tools menu allows the operator to set various machine settings.

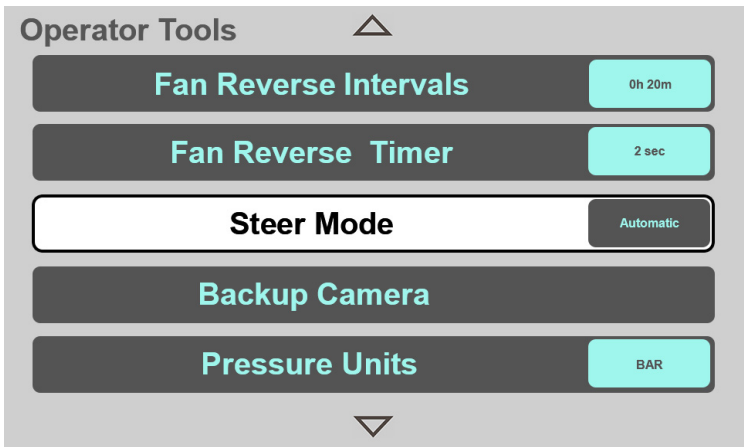

OAP0430

Steer Mode: Steer mode allows the operator to select desired steer mode.

- a. Manual steer mode
- b. Automatic steer mode

Fan Reverse Timer (if equipped): Fan reverse timer allows the operator to set the duration to rotate the fan in reverse direction.

Fan Reverse Interval (if equipped): Fan reverse interval allows the operator to set the interval between fan reversals.

Default Gear: Default gear allows the operator to set the default transmission gear when engine is started.

Elevated Idle: Elevated idle allows the operator to set the elevated idle.

Vehicle Speed Units: Vehicle speed units allows the operator to set the units for vehicle speed in KPH or MPH.

Temperature Units: Temperature units allows the operator to set the units for temperature in Celsius (C) or Fahrenheit (F).

Pressure Units: Pressure units allows the operator to set the units for pressure in BAR or PSI.

Backup Camera (if equipped): Backup camera allows the operator to temporarily view the area behind the telehandler on the home screen.

Tire Selection: Tire selection allows the operator to select applicable tire.

Section 3- Controls and Indicators

Calibrations

Calibrations menu allows the operator to perform functionality checks for various machine controls.

- Park brake test. See page 3-70.
- See Service Manual for more calibrations information.

Error Messages (Fault Codes)

Error messages screen allows the operator to view up to 25 recently logged Diagnostic Trouble Code (DTC)/Diagnostics Message 1 (DM1) fault codes along with a text description. The fault codes are displayed in the order in which they are received. Active fault codes are shown with an asterisk symbol. See Service Manual for additional fault code information.

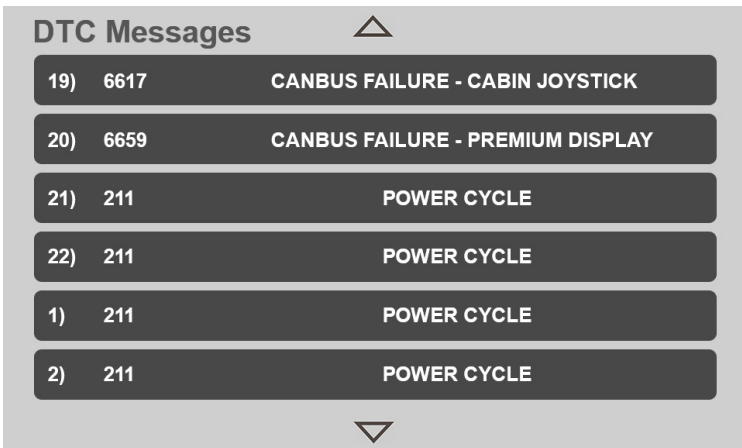

OAP0110

DTC Messages: DTC messages display all machine related fault codes. The DTC message consists of a three to five digit number and corresponding message.

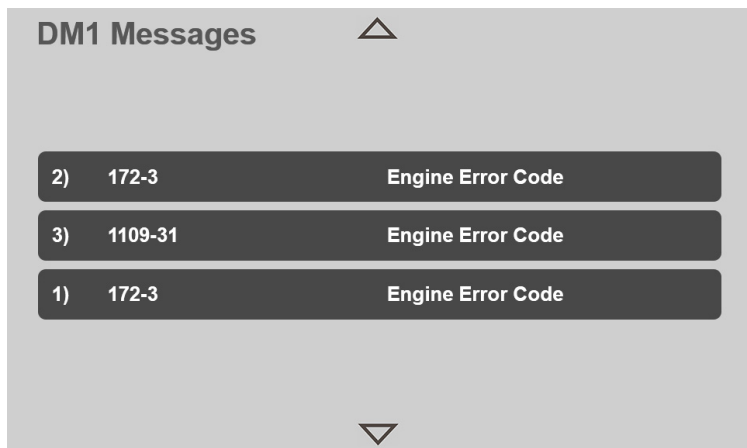

OAP0120

DM1 Messages: DM1 messages display all engine related fault codes. The DM1 message consists of the Suspect Parameter Number (SPN) and Fault Mode Indicator (FMI) component.

Visibility Chart

Visibility chart allows the operator to view the applicable visibility chart. See page 3-74.

Section 3- Controls and Indicators

Operation and Maintenance

Anti-Theft Functionality

Machines with anti-theft feature active require entering a numeric code before operation to prevent unauthorized use. If multifunction display is installed, anti-theft feature is accessed from that display only.

Note: If the anti-theft feature is active and the current access code is not known, it may be viewed or changed by the machine owner. See Service Manual.

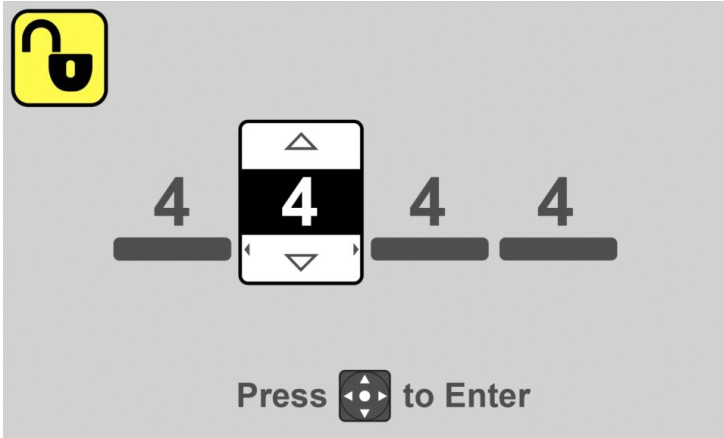

OD1920

1. Turn ignition switch to position 1. If anti-theft is active, the display will prompt the operator for a numeric code.
2. Press the up/down arrows of the Navigation button to select the first digit.
3. Press the right arrow of the Navigation button to move to the next digit.
4. Continue until the code is complete. Press the center of the Navigation button to confirm the code.
5. If an incorrect code is entered, the display will prompt the operator again for the numeric code.
6. If the correct code is entered, normal start up can continue.

Capacity Chart Selection

The home screen displays proper capacity chart based on the selected attachment, and if equipped, selected outriggers position.

A. Attachment Selection

The attachment selection button allows the operator to select a specific attachment in order to display the applicable capacity chart.

1. Press the Attachment Select button to access the types of attachments.

Note: The Competitive Coupler type is only visible when enabled. See "Display Settings" on page 3-52.

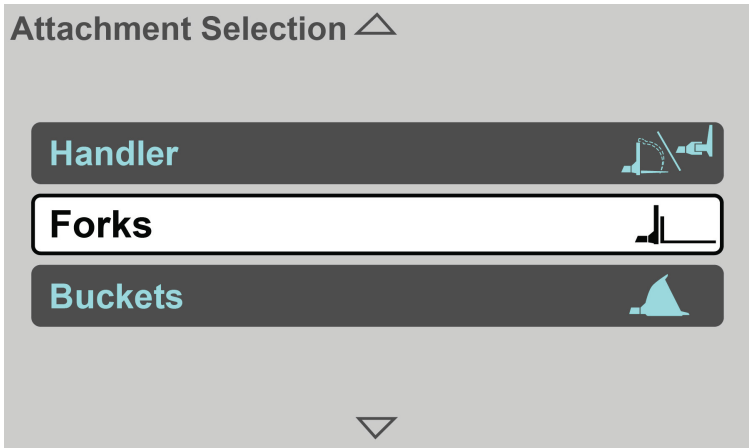

OAP0130

2. Select the type of attachment.

Note: Scroll up or down to view all items.

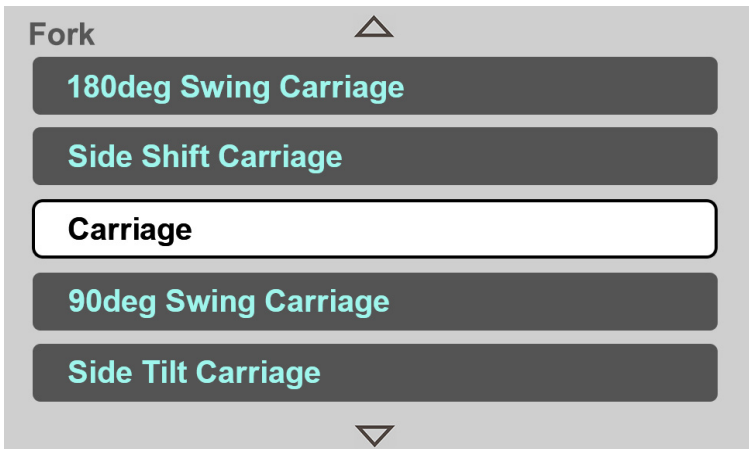

OAP0140

Section 3- Controls and Indicators

3. Select the specific attachment to be used.

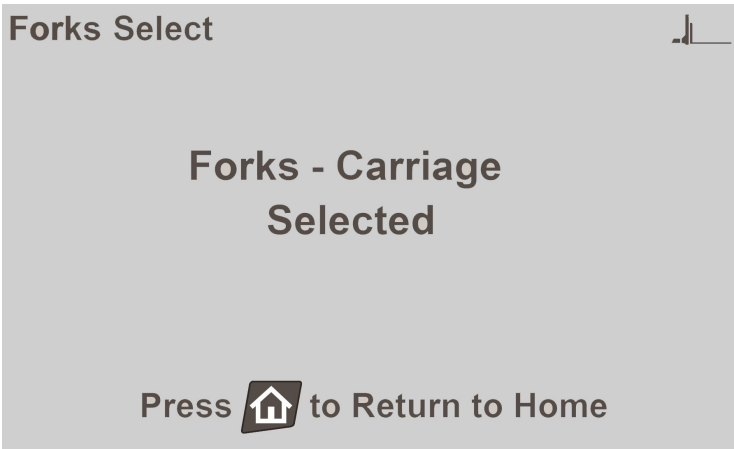

OAP0150

4. A message screen will display to confirm the selection. Press Home Screen button to go to home screen, the capacity chart for the selected attachment will display.

B. Outriggers Position Selection (if equipped)

If machine is equipped with outriggers, the display will show the capacity chart based on the outriggers position. See page 5-6 for use of the capacity chart.

Manual:

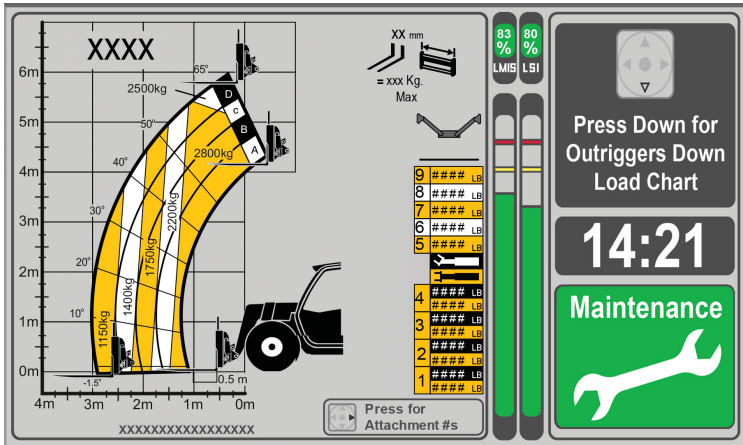

OAP0570

If machine is not equipped with proximity and pressure sensors to detect the status of outriggers position, the operator must select the applicable capacity chart manually.

Note: The default capacity chart is outriggers up.

1. Press down arrow of the Navigation button to display outriggers down capacity chart.
2. Press up arrow of the Navigation button to display outriggers up capacity chart.

Section 3- Controls and Indicators

Semi-automatic:

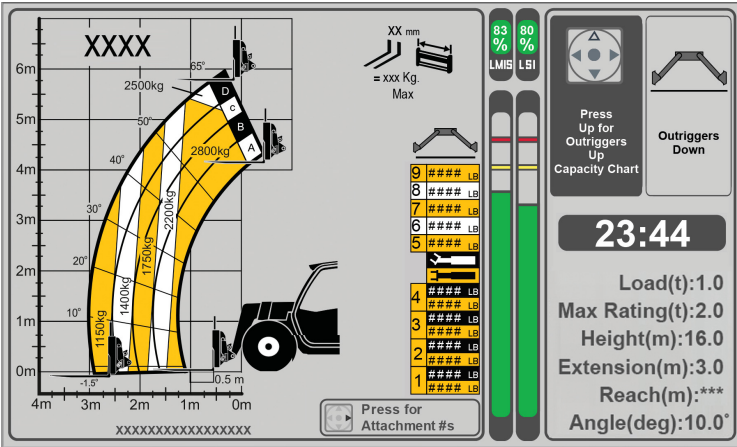

OAP0590

If machine is equipped with pressure sensor only, the display will show the outrigger status and the operator requires to confirm the outrigger status with navigation button.

Automatic:

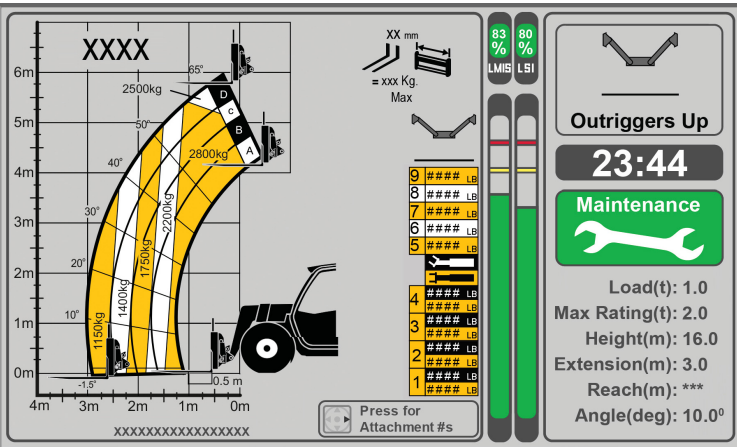

OAP0490

The proximity and pressure sensors detect the status of the outriggers position and automatically displays the corresponding capacity chart on the home screen.

Reversing Camera (if equipped)

WARNING

CRUSH HAZARD. Running into persons or objects can cause death, serious injury, or damage to property and equipment. Always check mirrors and area behind vehicle before and when backing up. Reverse systems are for supplementary use only.

The reversing camera provides an additional view of the area directly behind the telehandler. The view displays on the multifunction display home screen when the telehandler is running, transmission is in reverse and when backup camera is configured to be present under machine setup. The display automatically returns to the standard home screen when transmission is shifted out of reverse.

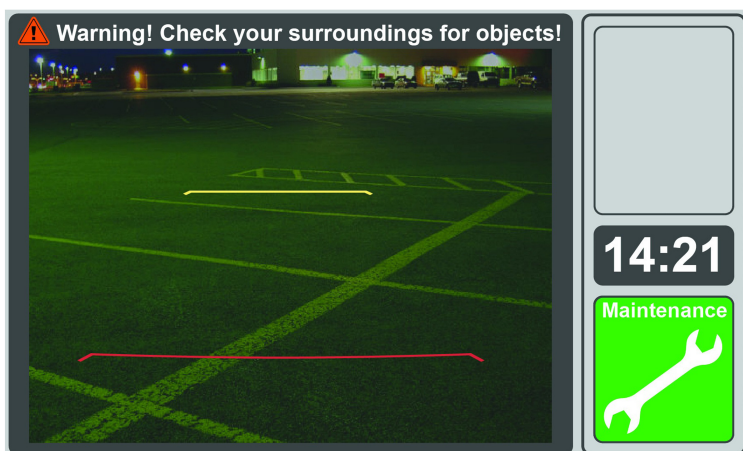

OAP0160

The screen provides a graphic overlay indicating approximate distances of objects at rear of telehandler.

- **Red Line:** Approximately 1,52 m (5 ft).
- **Yellow Line:** Approximately 4,57 m (15 ft).

NOTICE

EQUIPMENT MALFUNCTION. Always keep camera lens clean. Camera may not operate normally at extremely high or low temperatures.

Section 3- Controls and Indicators

Maintenance Schedule Screen

Maintenance schedules identify maintenance tasks required when operating hours reach an identified interval.

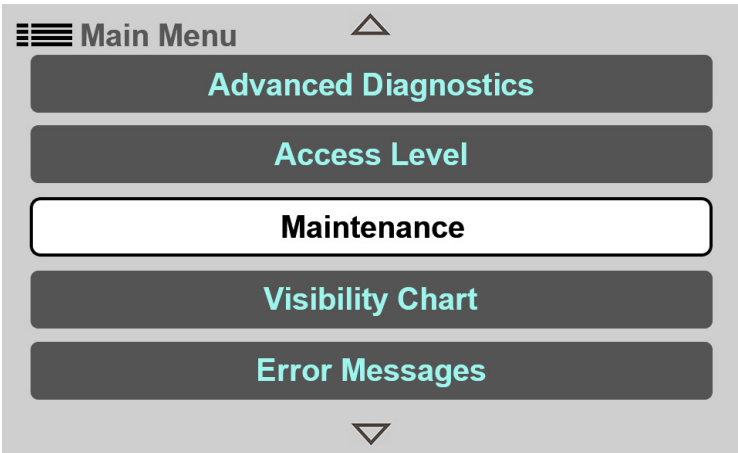

OAP0410

1. Press Main Menu button and select Maintenance.

Note: Scroll up or down to view all items.

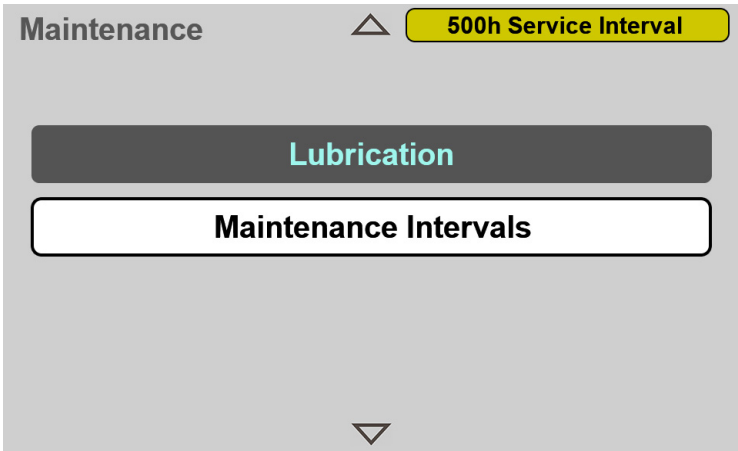

OAP0170

2. Select Maintenance Intervals.

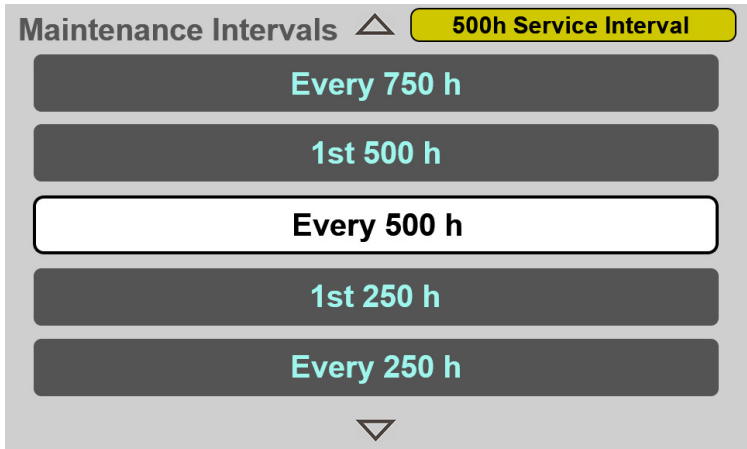

OAP0180

3. Select the required maintenance interval to view the maintenance schedule. See Section 7- Lubrication and Maintenance for additional information.

Note: The screen will display the current maintenance interval in the upper right corner when scheduled operating hours are reached.

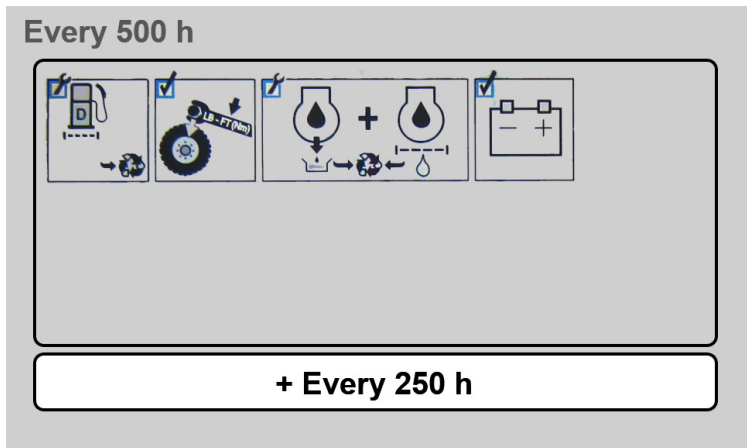

OAP0190

4. Press the center of the Navigation button to view subsequent maintenance schedules until maintenance intervals screen displays.

Section 3- Controls and Indicators

Lubrication Schedule Screen

Lubrication schedules identify lubrication tasks required when operating hours reach an identified interval.

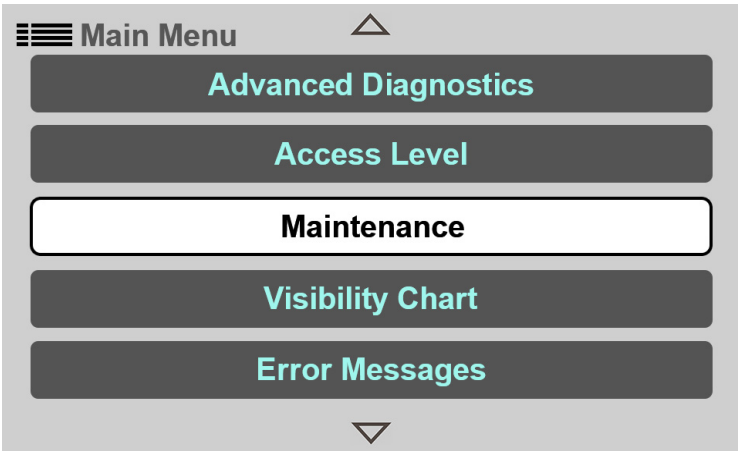

OAP0410

1. Press Main Menu button and select Maintenance.

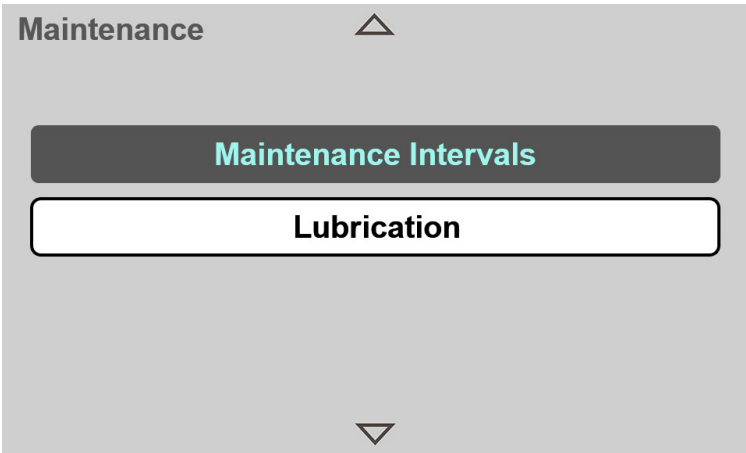

OAP0200

2. Select Lubrication to view the lubrication schedule.

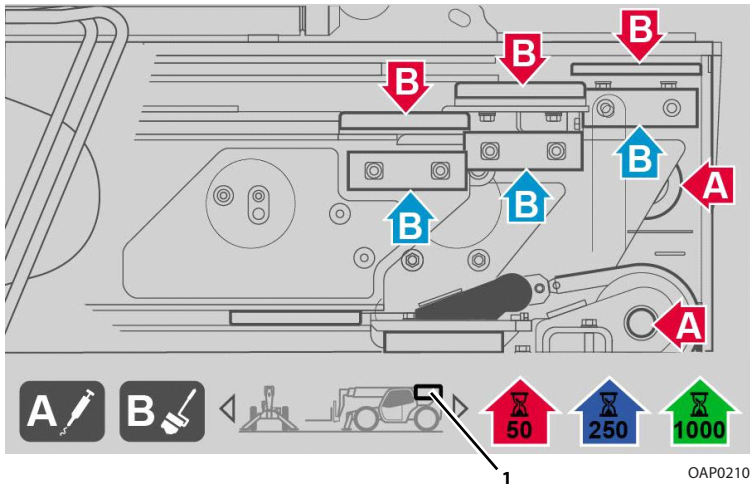

3. Use left/right arrow of the Navigation button to view lubrication points in different locations. See Section 7- Lubrication and Maintenance for additional information.

Note: Rectangle (1) indicates the area of the machine displayed on the screen above.

Section 3- Controls and Indicators

Real-Time Clock (RTC) Setup

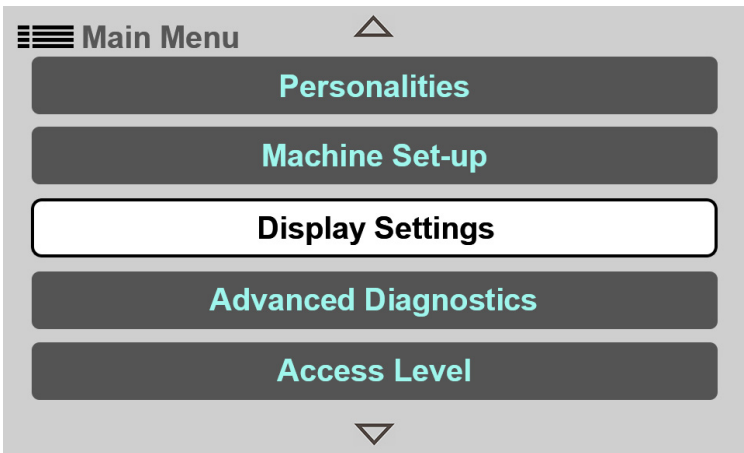

OAP0220

1. Press Main Menu button and select Display Settings.

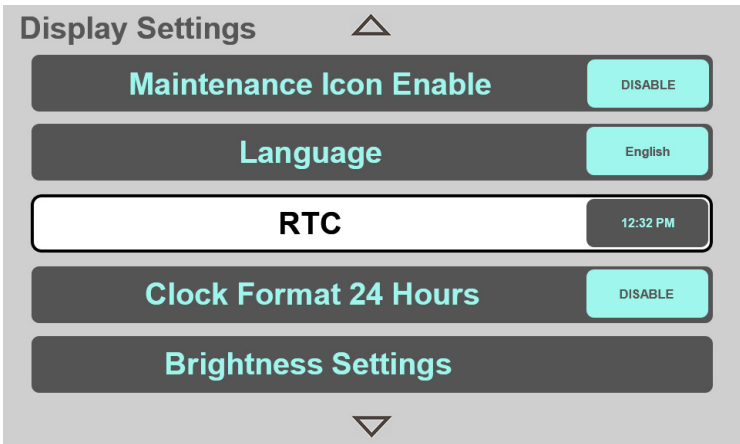

OAP0230

2. Select RTC to set the date and time.

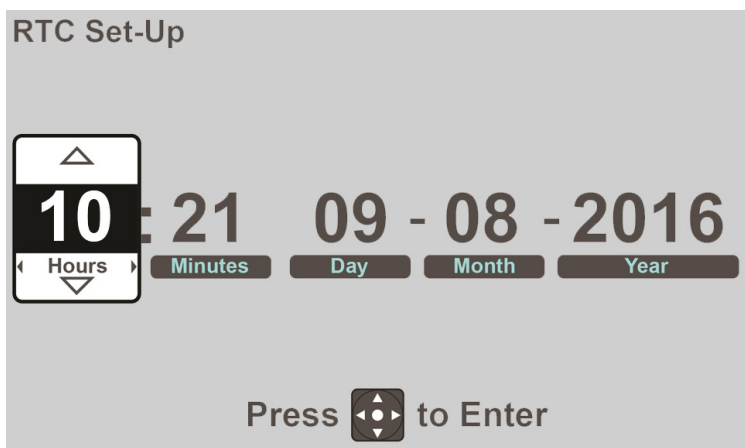

OAP0440

3. Press the up/down arrow of the Navigation button to select the first digit.
4. Press the right arrow of the Navigation button to move to the next digit.
5. Continue until the set-up is complete. Press the center of the Navigation button to confirm.

Section 3- Controls and Indicators

Park Brake Test

Park brake test allows the operator to check the function of park brake.

Note: Each step of the calibration procedure must be completed within 60 seconds. If not, then the calibration fails and need to initiate the calibration procedure again.



WARNING

CRUSH HAZARD. Running into persons or objects can cause death, serious injury, or damage to property and equipment. Always check mirrors and area around machine before performing any test. Apply service brake if machine moves.

1. Apply park brake and start engine to perform the test.

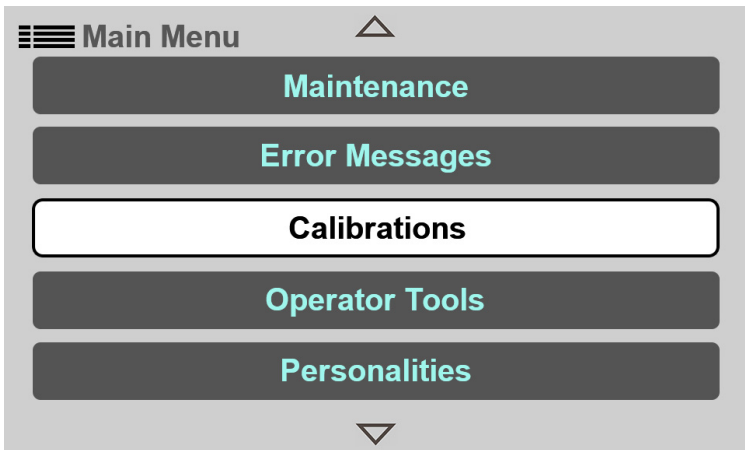

OAP0250

2. Press Main Menu button and select Calibrations.

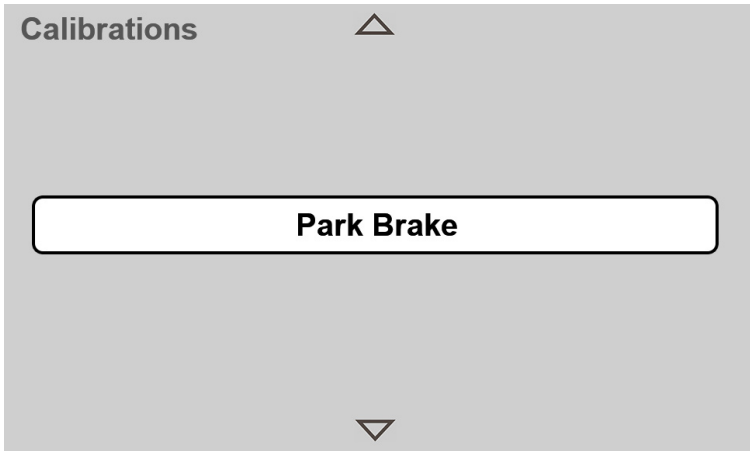

OAP0260

3. Select Park Brake.

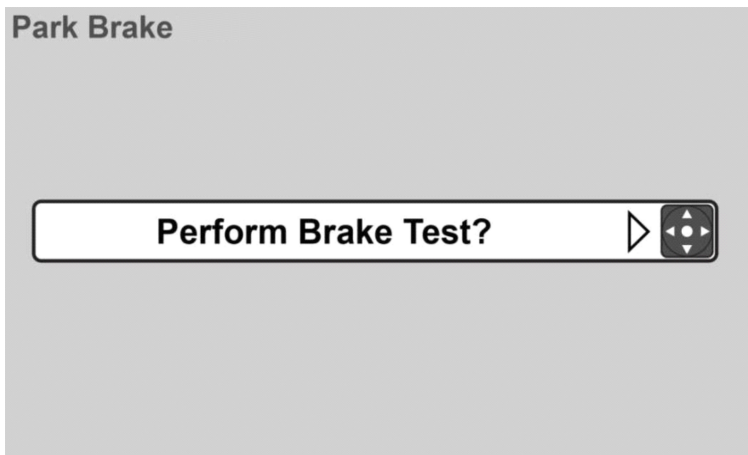

OAP0270

4. Press center of the Navigation button to confirm "Perform Brake Test?".

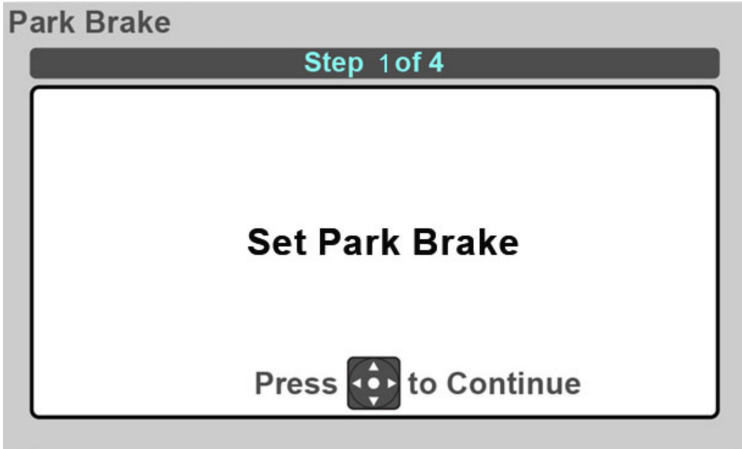

OAP0280

5. Ensure the park brake is engaged. Press center of the Navigation button to confirm.



OAP0290

6. Display shows warning message, "Warning: Drive will be engaged". Place transmission in second gear. Press center of the Navigation button to continue.

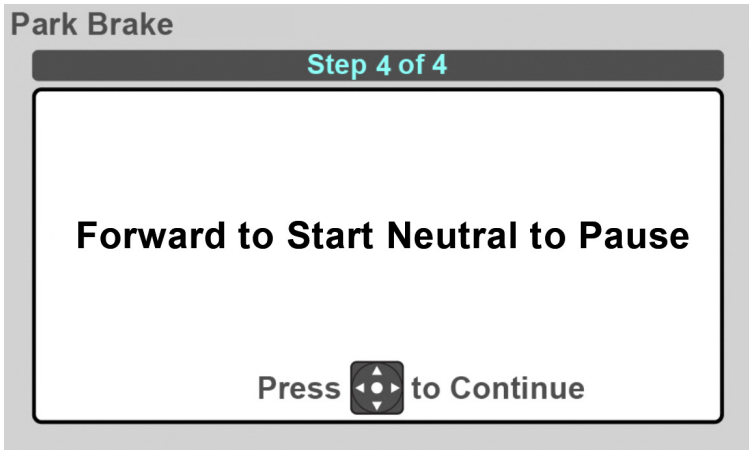

OAP0300

7. Place the transmission in Forward (F).
8. Place the transmission in Neutral (N). Press center of the Navigation button to continue.
9. "Park Brake Test Complete" will be displayed if successful. Press center of the Navigation button to confirm and return to calibrations menu.
"Park Brake Test Failed" will be displayed if failed. Press center of the Navigation button to confirm and return to calibrations menu to repeat the test. If failed again, machine must be removed from service and repaired before continued operation.

Section 3- Controls and Indicators

Visibility Chart Screen

Visibility chart screen allows the operator to view applicable visibility charts.



CRUSH HAZARD. Running into persons or objects can cause death, serious injury, or damage to property and equipment. Always check mirrors and area around machine before moving.

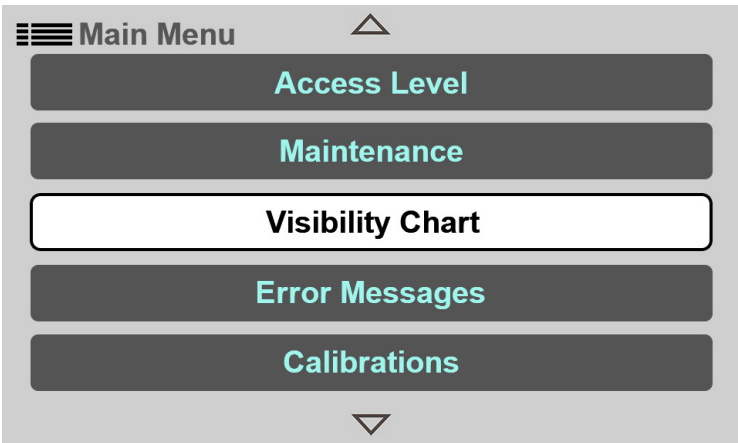

OAP0450

1. Press Main Menu button and select Visibility Chart.

Note: Scroll up or down to view all items.

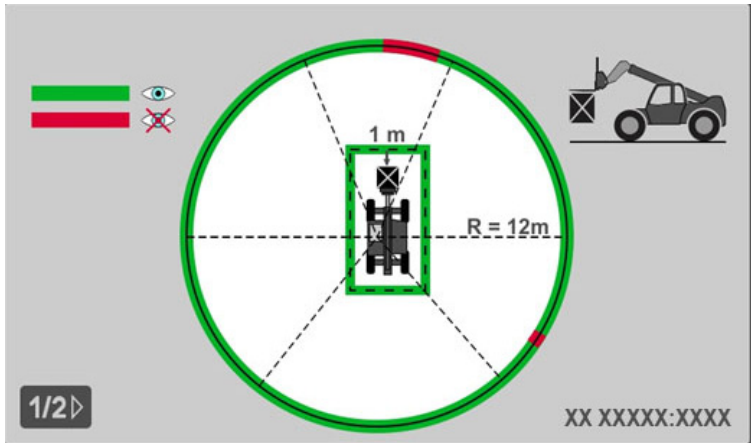

OAP0460

2. The screen will display default visibility chart with suspended load.

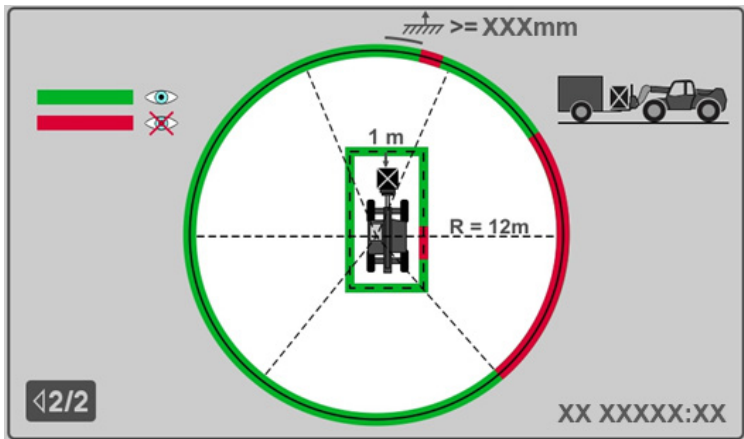

OAP0470

3. Press right arrow of the Navigation button to display visibility chart with non-suspended load.

Troubleshooting

Communication Error Screen



OAP0310

Communication error screen will be displayed if there is a communication failure. Wait for a few moments and restart the machine. If the communication error continues to display, refer service manual for more information.

SECTION 4 - OPERATION

4.1 ENGINE

Note: Refer to Engine Operation & Maintenance Manual for additional information.

Starting the Engine

This machine can be operated under normal conditions in temperatures of -18°C to 48°C (0°F to 118°F). Consult Telehandler Product Group for operation outside this range or under abnormal conditions.

If equipped for extreme cold weather, -40°C to -20°C (-40°F to 0°F), see page 4-2 for starting procedure.

1. Turn on electrical master switch.
2. Make sure all controls are in "Neutral" and all electrical components (lights, heater, etc.) are turned off. Apply park brake.
3. Turn ignition switch to position 1 and wait for engine preheat indicator on instrument panel to go out.
4. Turn ignition switch to position 2 to engage starting motor. Release key immediately when engine starts. If engine fails to start within 20 seconds, release key and allow starting motor to cool for a few minutes before trying again.

Note: If engine fails to start after three attempts, turn key to OFF position and allow starting motor to cool for 30 minutes before trying again.

5. After engine starts, observe indicators. If indicators remain on for more than five seconds, stop engine and determine cause before restarting engine.
6. Warm up engine at approximately 1/2 throttle.

Note: Engine will not start unless transmission is in neutral and park brake is applied.



WARNING

UNEXPECTED MOVEMENT HAZARD. Always ensure that transmission is in neutral and the service brake is applied before releasing park brake. Releasing park brake in either forward or reverse could cause the machine to move abruptly.



WARNING

ENGINE EXPLOSION. Do not spray ether into air intake for cold weather starting.

Section 4- Operation

Extreme Cold Weather Starting (if equipped)

If equipped with extreme cold weather components, machine can be operated in temperatures of -40° C to -20° C (-40°F to 0°F).

1. Machine must be equipped with heating components and extreme cold weather fluids. See Section 9- Specifications for fluid details.
2. Locate the two yellow extension cords stored behind seat in cab.
3. Connect the hydraulic tank heater to one extension cord and the battery and block heaters to the other extension cord. Connect each extension cord to separate A/C power supplies with a minimum rating of 15 Amps each.
4. Allow the heating components to operate a minimum of 12 hours prior to machine operation.
5. Follow start-up procedure on page 4-1 and allow engine to idle 20 minutes.
6. Operate all boom functions continuously for five minutes to circulate the warm hydraulic fluid.
7. Perform "*Shut-Down Procedure*" on page 4-6.
8. Disconnect A/C power supplies and place back in storage locations.
9. Machine is ready for operation.

Battery Boosted Starting

TH306D



OW0530

If battery-boost starting (jump-start) is necessary, proceed as follows:

- Never allow vehicles to touch.
- Ensure boosting vehicle engine is running.

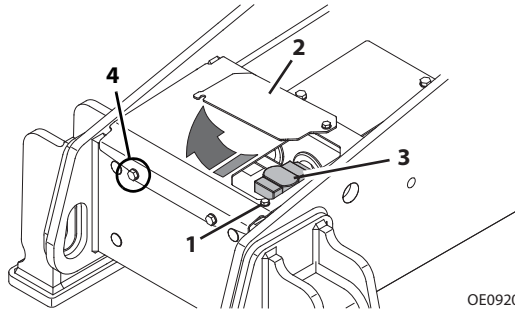

- Battery is located in the frame at the front of the machine for jump-starting.
- Loosen thumb screw (1) from the battery access panel (2) and swing panel aside.
- Connect positive (+) jumper cable to positive (+) post (3) of discharged battery.
- Connect opposite end of positive (+) jumper cable to positive (+) post of booster battery.
- Connect negative (-) jumper cable to negative (-) post on booster battery.
- Connect opposite end of negative (-) jumper cable to bolt head on machine (4).
- Follow standard starting procedures.
- Remove cables in reverse order after machine has started.
- Swing battery access panel back into place and tighten bolt.



WARNING

BATTERY EXPLOSION HAZARD. Never jump-start or charge a frozen battery as it could explode. Keep sparks, flames and lighted smoking materials away from battery. Lead acid batteries generate explosive gases when charging. Wear safety glasses.

Section 4- Operation

TH357D, TH408D, TH3510D



OW0530

If battery-boost starting (jump-start) is necessary, proceed as follows:

- Never allow vehicles to touch.
- Ensure boosting vehicle engine is running.

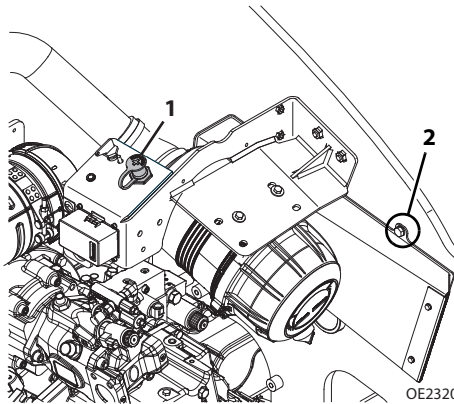

OE2320

- Remote battery post is located on right side of engine compartment for jump-starting.
- Connect positive (+) jumper cable to positive (+) post (1) of discharged battery.
- Connect opposite end of positive (+) jumper cable to positive (+) post of booster battery.
- Connect negative (-) jumper cable to negative (-) post on booster battery.
- Connect opposite end of negative (-) jumper cable to bolt head on machine (2).
- Follow standard starting procedures.
- Remove cables in reverse order after machine has started.



WARNING

BATTERY EXPLOSION HAZARD. Never jump-start or charge a frozen battery as it could explode. Keep sparks, flames and lighted smoking materials away from battery. Lead acid batteries generate explosive gases when charging. Wear safety glasses.

Normal Engine Operation

- Observe instrument panel and display frequently to be sure all systems are functioning properly.
- **Be alert for unusual noises or vibration.** When an unusual condition is noticed, park machine in safe position and perform shut-down procedure. Report condition to your supervisor or maintenance personnel.
- **Avoid prolonged idling.** If engine is not being used, turn it off.
- If prolonged idling is required (park brake applied and all controls in neutral), engine idle may increase.
 - Driving lights on.
 - Air conditioning on.
 - Ambient temperature below -17° C (-1° F).
- When operating a machine at high altitudes, a decrease in machine performance may occur due to a decrease in air density. When operating a machine at high temperatures, a decrease in machine performance and an increase in engine coolant temperature may occur. Contact the local Caterpillar dealer for operation under abnormal conditions.

Section 4- Operation

Shut-Down Procedure

When parking the telehandler, park in a safe location on flat level ground and away from other equipment and/or traffic lanes.

1. Apply park brake.
2. Shift transmission to "Neutral".
3. Lower forks or attachment to ground.
4. Operate engine at low idle for 3 to 5 minutes. **DO NOT over rev engine.**
5. Shut off engine and remove ignition key.
6. Exit telehandler properly.

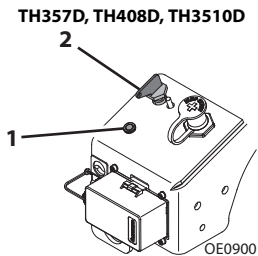
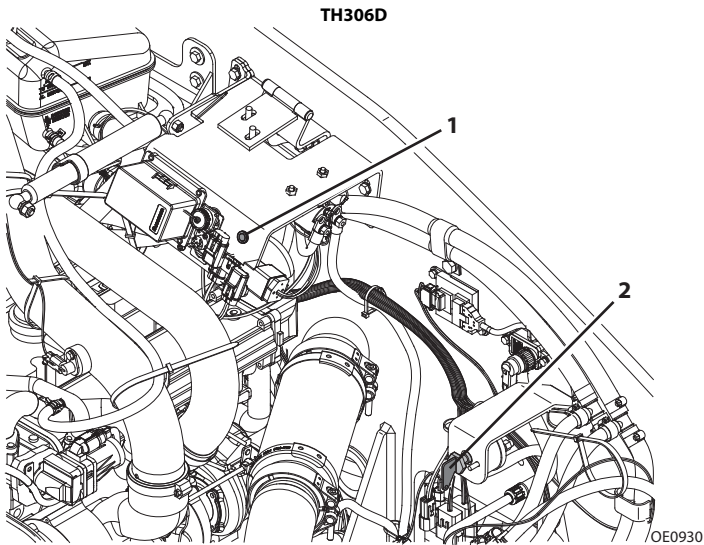

7. During machine shutdown, purge indicator (1) will illuminate until DEF is purged from the system. Do not turn key (2) to off while indicator is illuminated.
8. Turn off electrical master switch.
9. Block wheels (if necessary).

This Page Intentionally Left Blank

Section 4- Operation

4.2 AFTER-TREATMENT SYSTEM (ATS) (SN TD200150 TO PRESENT, SN TA200150 TO PRESENT)

This machine is equipped with an exhaust After-Treatment System. Selective Catalytic Reduction (SCR) Indicator (2) will slowly blink when a maintenance/desulphurization or decrystallization refresh is required. Prior to a stationary exhaust system cleaning, ensure all stationary conditions are met.

1. Move telehandler to a level area free of flammables and people that could be exposed to hot exhaust.
2. Keep engine warm (coolant temperature above 39°C) and at idle speed and ensure no engine system faults are active.
3. Shift transmission to neutral, retract and lower boom and engage park brake.

Note: In cold environments, ensure DEF tank is thawed so that DEF pump can prime and inject.

Stationary Exhaust System Cleaning

To initiate stationary exhaust system cleaning, hold instrument panel buttons (1) simultaneously for 3 seconds.

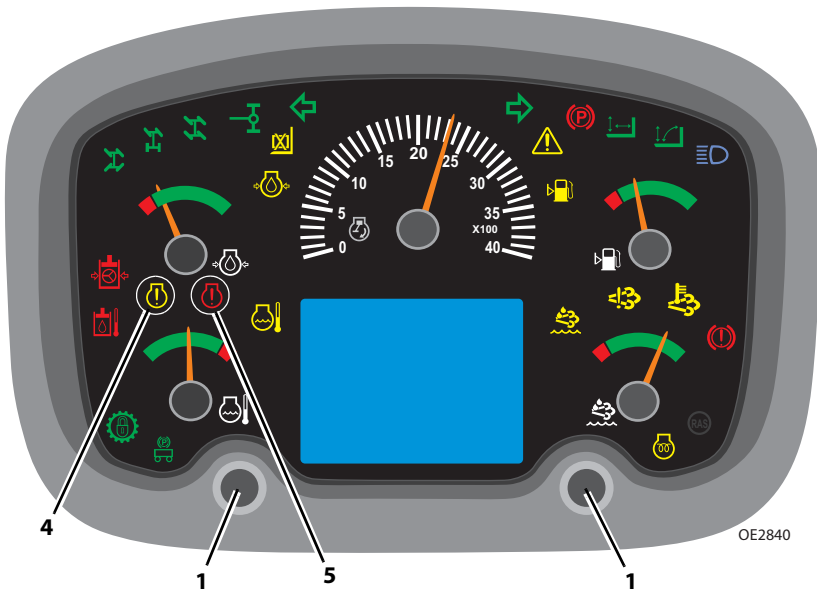

Note: Analyzer may also be used to initiate exhaust system cleaning (except during idle lock inducement).



WARNING

HIGH EXHAUST TEMPERATURE. Keep flammables and people away from hot exhaust.

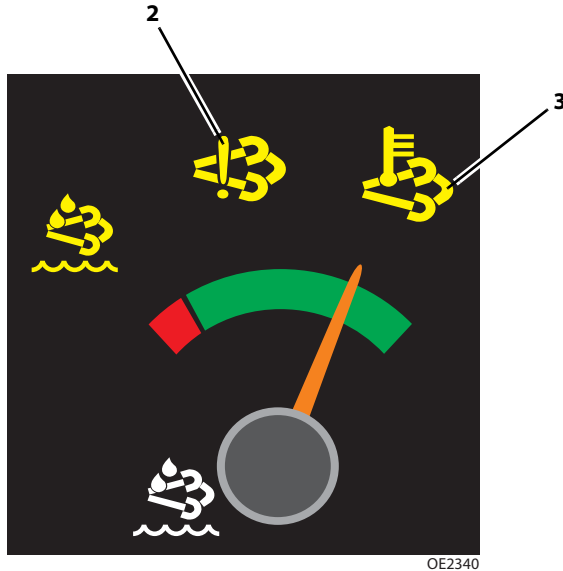

1. SCR (2) and High Exhaust System Temperature (HEST) (3) Indicators will illuminate during stationary exhaust system cleaning.

Note: Do not operate boom controls, park brake or accelerator pedal during exhaust system cleaning. Stationary exhaust system cleaning will stop and may be incomplete if any controls are inadvertently moved or activated.

2. If exhaust system cleaning is interrupted, both instrument panel buttons (1) must be pressed again simultaneously for 3 seconds to re-initiate cycle.
3. Exhaust system cleaning takes up to approximately 35 minutes. Stationary exhaust system cleaning is complete after SCR and HEST indicators go off.
4. If exhaust system cleaning is unsuccessful, SCR indicator (2) will turn off for 2 seconds before resuming a slow blink. Ensure all stationary conditions have been met.

NOTICE

EQUIPMENT DAMAGE. If exhaust system cleaning is ignored, Engine Fault Warning Indicator (4) will illuminate and a 25% power derate will begin. Immediately bring machine to a stop and perform stationary exhaust system cleaning. If cleaning is still ignored, Engine Fault Critical Indicator (5) will illuminate and engine will go into idle speed lock. Contact the local dealer.

Section 4- Operation

4.3 OPERATING WITH A NON-SUSPENDED LOAD

Lift Load Safely

- You must know weight and load center of every load you lift. If you are not sure of weight and load center, check with your supervisor or with supplier of the material.



WARNING

TIP OVER HAZARD. Exceeding lift capacity of the telehandler could damage the equipment and/or cause tip over.

- Know rated load capacities (refer to Section 5) of telehandler to determine operating range in which you can safely lift, transport and place a load.

Picking Up a Load

- Note conditions of the terrain. Adjust travel speed and reduce amount of load if conditions warrant.
- Avoid lifting double-tiered loads.
- Make sure load is clear of any adjacent obstacles.
- Adjust spacing of forks so they engage the pallet or load at maximum width. See *"Adjusting/Moving Forks"* on page 5-21.
- Approach load slowly and squarely with fork tips straight and level. **NEVER** attempt to lift a load with just one fork.
- **NEVER** operate telehandler without a proper and legible capacity chart in operator cab for telehandler/attachment combination you are using.

Transporting a Load



- After engaging the load and resting it against the backrest, tilt the load back to position it for travel. Travel in accordance with the requirements set forth in Section 1- General Safety Practices and Section 5- Attachments and Hitches.

Leveling Procedure

1. Position machine in best location to lift or place load.
2. Apply parking brake and shift transmission to NEUTRAL.
3. Observe level indicator(s) to determine whether machine must be leveled prior to lifting load.
4. Reposition machine to level.

Important things to remember:

- Never raise boom/attachment more than 1,2 m (4 ft) above ground unless telehandler is level.
(AUS - Never raise the forks more than 300 mm (11.8 in) above ground surface unless telehandler is level.)
- Combination of frame leveling and load could cause telehandler to tip over.

Section 4- Operation

Placing a Load

Before placing any load be sure that:

- Landing point can safely support weight of the load.
- Landing point is level; front to back and side to side.
- Use capacity chart to determine safe boom extension range. See *"Use of the Capacity Chart"* on page 5-6.
- Align forks at level the load is to be placed, then position boom slowly until load is just above area where it is to be placed.
- Lower the boom until the load rests in position and the forks are free to retract.

Disengaging a Load

Once the load has been placed safely at the landing point, proceed as follows:

1. With forks free from weight of load, boom can be retracted.
2. Lower carriage.
3. Telehandler can now be driven from landing location to continue work.

4.4 OPERATING WITH A SUSPENDED LOAD

Lift Load Safely

- You must know weight and load center of every load you lift. If you are not sure of weight and load center, check with your supervisor or with supplier of the material.



WARNING

TIP OVER HAZARD. Exceeding lift capacity of the telehandler could damage the equipment and/or cause tip over.

- Know rated load capacities (refer to Section 5) of telehandler to determine operating range in which you can safely lift, transport and place a load.

Picking Up a Suspended Load

- Note conditions of terrain. Adjust travel speed and reduce amount of load if conditions warrant.
- Avoid lifting double-tiered loads.
- Make sure load is clear of any adjacent obstacles.
- **NEVER** operate telehandler without a proper and legible capacity chart in operator cab for telehandler/attachment combination you are using.
- Only use approved lifting devices rated for lifting of load.
- Identify proper lifting points of load, taking into consideration center of gravity and load stability.
- Ensure to always properly tether loads to restrict movement.
- Refer to “*Use of the Capacity Chart*” on page 5-6 for proper lifting guidelines in addition to appropriate capacity chart in operator cab.

Section 4- Operation

Transporting a Suspended Load



OZ3160

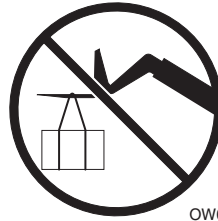

OW0130

- Travel in accordance with the requirements set forth in Section 1- General Safety Practices and Section 5- Attachments and Hitches.
- For additional requirements, refer to appropriate capacity chart in operator cab.

Important things to remember:

- Ensure boom is fully retracted.
- Never raise load more than 300 mm (11.8 in) above ground surface or boom more than 45°.
- Combination of frame leveling and load could cause telehandler to tip over.
- Guide persons and operator must remain in constant communication (verbal or hand) and be in visual contact with operator at all times.
- Never place guide persons between suspended load and telehandler.
- Only transport load at walking speed, 1.4 kph (0.9 mph), or less.

Leveling Procedure

1. Position machine in best location to lift or place load.
2. Apply parking brake and shift transmission to NEUTRAL.
3. Observe level indicator(s) to determine whether machine must be leveled prior to lifting load.
4. Reposition machine to level.

Placing a Suspended Load

Before placing any load be sure that:

- Landing point can safely support weight of load.
- Landing point is level; front to back and side to side.
- Use capacity chart to determine safe boom extension range. See *"Use of the Capacity Chart"* on page 5-6.
- Align load at level the load is to be placed, then position boom slowly until load is just above area where it is to be placed.
- Ensure that guide persons and operator remain in constant communication (verbal or hand) when placing load.

Disengaging a Suspended Load

- Never place guide persons between suspended load and telehandler.
- Once at destination of load, ensure to bring telehandler to a complete stop and apply park brake prior to disengagement of lifting devices and tethers.

Section 4- Operation

4.5 ROAD OPERATION (CE)

1. Preparation
 - a. Remove load from attachment.
 - b. Remove any large amounts of dirt from machine.
 - c. Check lights and mirrors and adjust if necessary.

Note: Be sure to follow all local and federal/provincial traffic regulations.

2. Lower boom. Lowest part of attachment should be approximately 30 cm (12 in) above the ground.
3. Fully tilt attachment back.
4. Place protective shield over front bucket edge: remove or reposition carriage forks toward the machine and secure to the carriage.

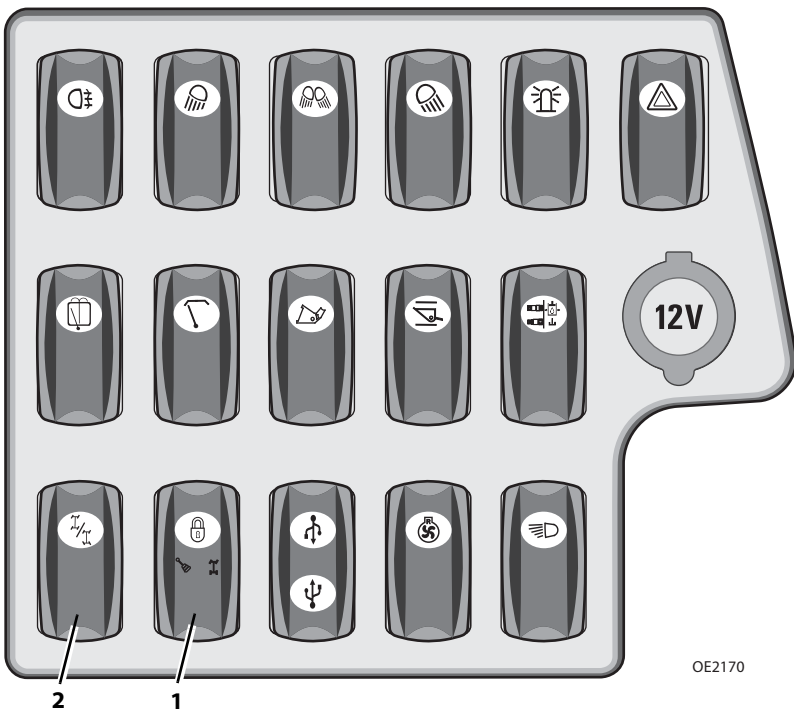

OE2170

5. Depress button (1) to deactivate joystick function and disable all joystick controlled functions.
6. Changes steer mode to front wheel steering (2). See "Steer Modes" on page 3-34 for details.
7. Machine is now ready for road operation.

4.6 LOADING AND SECURING FOR TRANSPORT

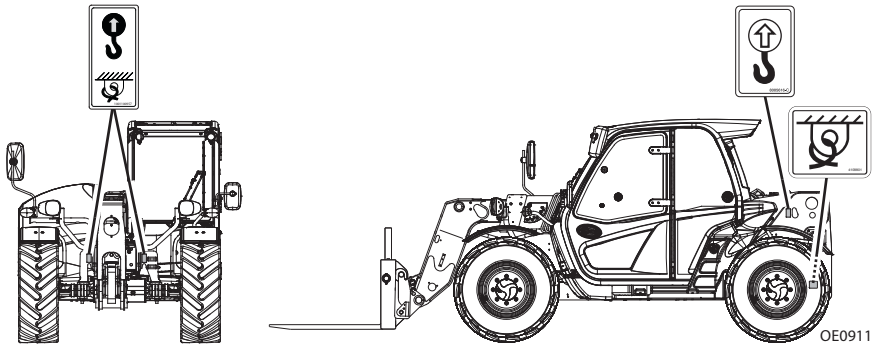

Tie Down

1. Level telehandler prior to loading.
2. Using a spotter, load telehandler with boom as low as possible.
3. Once loaded, apply parking brake and lower boom until boom or attachment is resting on deck. Move all controls to "Neutral," stop engine and remove ignition key.
4. Secure machine to deck by passing chains through designated tie down points as shown in figure.
5. Do not tie down front of boom.

Note: User assumes all responsibility for choosing proper method of transportation and tie-down devices, making sure equipment used is capable of supporting weight of vehicle being transported and that all manufacturer's instructions and warnings, regulations and safety rules of their employer, Department of Transportation and/or any other local, state or federal/provincial laws are followed.



WARNING

TELEHANDLER SLIDE HAZARD. Before loading telehandler for transport, make sure deck, ramps and telehandler wheels are free of mud, snow and ice. Failure to do so could cause telehandler to slide.

Section 4- Operation

Lifting

- When lifting machine, it is very important that the lifting device and equipment is attached only to designated lifting points. If machine is not equipped with lifting lugs contact the local Caterpillar dealer for information.
- Make adjustments to the lifting device and equipment to ensure the machine will be level when elevated. The machine must remain level at all times while being lifted.
- Ensure that the lifting device and equipment is adequately rated and suitable for the intended purpose. See Section 9- Specifications for machine weight or weigh machine.
- Remove all loose items from machine prior to lifting.
- Lift machine with smooth, even motion. Set machine down gently. Avoid quick or sudden motions that could cause shock loads to machine and/or lifting devices.

SECTION 5 - ATTACHMENTS AND HITCHES

5.1 APPROVED ATTACHMENTS

To determine if an attachment is approved for use on the specific telehandler you are using, perform the following prior to installation.

- The attachment type, weight, dimensions and load center must be equal to or less than the data shown on a capacity chart located in the operator cab.
- The model on the capacity chart must match the model telehandler being used.
- Hydraulically powered attachments must only be used on machines equipped with auxiliary hydraulics.
- Hydraulically powered attachments that require auxiliary electrics must only be used on machines equipped with auxiliary hydraulics and electrics.

If any of the above conditions are not met, do not use the attachment. The telehandler may not be equipped with the proper capacity chart or the attachment may not be approved for the model telehandler being used. Contact the local Caterpillar dealer for further information.

5.2 UNAPPROVED ATTACHMENTS

Do not use unapproved attachments for the following reasons:

- Range and capacity limitations for “will fit,” homemade, altered, or other non-approved attachments cannot be established.
- An overextended or overloaded telehandler can tip over with little or no warning and cause serious injury or death to the operator and/or those working nearby.
- The ability of a non-approved attachment to perform its intended function safely cannot be assured.



WARNING

Use only approved attachments. Attachments which have not been approved for use with your telehandler could cause machine damage or an accident.

Section 5- Attachments and Hitches

5.3 JLG SUPPLIED ATTACHMENTS

Attachment	Part Number	TH306D		TH357D		TH408D		TH3510D	
		CE	AUS	CE	AUS	CE	AUS	CE	AUS
Carriage, 1225 mm (48 in)	498-6430	X	X						
Carriage, 1225 mm (48 in)	326-2013			X	X	X	X	X	X
Carriage, 1524 mm (60 in)	474-0135			X	X	X	X	X	X
Carriage, 1829 mm (72 in)	474-0136			X	X	X	X	X	X
Carriage, John Deere	513-7381			X		X		X	
Carriage, Manitou	487-0690			X		X		X	
Carriage, JCB	346-2975			X		X		X	
Fork Positioning Carriage 1270 mm (50 in)	479-0237	X	X	X	X	X	X	X	X
Fork Rotator Carriage 990 mm (39 in)	515-1158	X	X						X
Fork Rotator Carriage 1270 mm (50 in)	456-0454			X	X	X	X	X	X
Side Tilt Carriage 1200 mm (47.2 in)	231-3229	X	X	X	X	X	X	X	X
Side Tilt Carriage 1829 mm (72 in)	227-5748			X	X	X	X	X	X
Side Shift Carriage 1200 mm (47.2 in)	222-6210	X	X	X	X	X	X	X	X
Carriage, FEM	486-0527	X	X	X	X	X	X	X	X
Fork, Pallet 50x100x1200 mm (2x4x47.2 in)	326-1997	X		X		X		X	
Fork, Pallet 50x120x1250 mm (2x4.7x49.2 in)	364-5356	X		X		X		X	
Fork, Pallet 60x100x1200 mm (2.4x4x47.2 in)	326-1998	X	X	X	X	X	X	X	X
Fork, Pallet 50x100x1070 mm (2x4x42.1 in)	463-1675	X		X		X		X	
Fork, Pallet 50x100x1525 mm (2x4x60 in)	252-1456	X		X		X		X	
Fork, Pallet 60x100x1524 mm (2.4x4x60 in)	559-1414	X	X	X		X	X	X	X
Fork, Block 50x50x1220 mm (2x2x48 in)	485-7240	X	X	X	X	X	X	X	X
Fork, Lumber 40x150x1540 mm (1.6x5.9x60 in)	497-6985			X	X	X	X	X	X
Fork, Lumber 45x150x1540 mm (1.75x6x60 in)	525-9244			X	X	X	X	X	X

Section 5- Attachments and Hitches

Attachment	Part Number	TH306D		TH357D		TH408D		TH3510D	
		CE	AUS	CE	AUS	CE	AUS	CE	AUS
Fork Extension 50x100 mm (2x4 in)	485-7238	X	X	X		X		X	
Fork Extension 60x100 mm (2.4x4 in)	491-1372		X		X		X		X
Pipe Grapple	486-0526			X	X	X	X	X	X
Bale, Dual Tine, 1225 mm (48 in)	517-6817	X	X	X	X	X	X	X	X
Bale Handler	483-9533	X	X	X	X	X	X	X	X
Bucket, General Purpose 2100 mm-1,0 m ³ (82.7 in-1.3 yd ³)	503-0261	X	X						
Bucket, General Purpose 2100 mm-1,5 m ³ (82.7 in-2.0 yd ³)	503-0262	X	X						
Bucket, General Purpose 2100 mm-2,0 m ³ (82.7 in-2.6 yd ³)	503-0263	X	X						
Bucket, General Purpose 2450 mm-1,0 m ³ (96.5 in-1.3 yd ³)	456-0498			X	X	X	X	X	X
Bucket, General Purpose 2438 mm-1,5 m ³ (96.0 in-2.0 yd ³)	456-0507			X	X	X	X	X	X
Bucket with Teeth 1,0 m ³ (1.3 yd ³)	502-1235	X	X						
Bucket with Teeth 1,0 m ³ (1.3 yd ³)	474-2537			X	X	X	X	X	X
Bucket, Light Material 2,0 m ³ (2.6 yd ³)	220-4759			X	X	X	X	X	X
Bucket, Light Material 2,5 m ³ (3.3 yd ³)	220-4760			X	X	X	X	X	X
Bucket, Light Material 3,0 m ³ (3.9 yd ³)	220-4761			X	X	X	X	X	X
Bucket, Multi-Purpose 1,0 m ³ (1.3 yd ³)	486-0141			X	X	X	X	X	X
Concrete Bucket Mixer, 500 L	474-2534	X	X	X	X	X	X	X	X
Bucket, Grapple 1850 mm-1,0 m ³ (72 in-1.3 yd ³)	502-1236	X	X						
Bucket, Grapple 2100 mm-1,0 m ³ (83 in-1.3 yd ³)	502-1237	X	X						
Grapple, Multi-Purpose Grapple 0,8 m ³ (1.0 yd ³)	509-4664			X	X	X	X	X	X
Bucket, Manure Grapple 1,4 m ³ (1.8 yd ³)	502-1233	X	X						
Bucket, Manure Grapple 1,55 m ³ (2.0 yd ³)	509-4663			X		X		X	

Section 5- Attachments and Hitches

Attachment	Part Number	TH306D		TH357D		TH408D		TH3510D	
		CE	AUS	CE	AUS	CE	AUS	CE	AUS
Muck Fork, 2100 mm (82 in)	502-1234	X	X						
Muck Fork, 2400 mm (94 in)	509-4662			X	X	X	X	X	X
Sweeper	486-0528	X	X	X	X	X	X	X	X
Auger	491-9892	X	X	X	X	X	X	X	X
Truss Boom, 2,1 m (6.9 ft)	479-0239	X	X	X	X	X	X	X	X
Truss Boom, 3,7 m (12.1 ft)	474-0144	X	X	X	X	X	X	X	X
Truss Boom, 4,0 m (13.1 ft)	456-0473	X	X	X	X	X	X	X	X
Truss Boom, Adjustable 2,0 - 4,0 m (6.6 - 13.1 ft)	229-9714	X		X		X		X	
Truss Boom w/Winch 1 m (3.3 ft)	491-9893	X		X		X		X	
Truss Boom w/Winch 3.7 m (12.1 ft)	474-0147	X		X		X		X	
Coupler Mounted Hook	456-0465	X	X	X	X	X	X	X	X
Fork Mounted Hook	309-9182	X		X		X		X	
Trash Hopper, Fork Mounted	486-0529	X	X	X	X	X	X	X	X

5.4 TELEHANDLER/ATTACHMENT/FORK CAPACITY

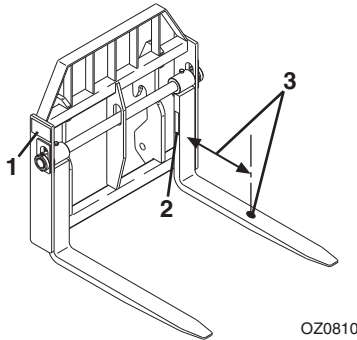

Prior to installing attachment, verify it is approved and telehandler is equipped with proper capacity chart. See “*Approved Attachments*” on page 5-1.

To determine maximum capacity of telehandler and attachment, use the **smallest** of the following capacities:

- Capacity stamped on attachment identification plate (1).
- Fork capacities and load centers are stamped on the side of each fork (2) (if equipped). This rating specifies maximum load capacity that the individual fork can safely carry at maximum load center (3). Total attachment capacity is multiplied by number of forks on attachment (if equipped), up to maximum capacity of attachment.
- Maximum capacity as indicated on the proper capacity chart. See “*Approved Attachments*” on page 5-1.
- When load rating of telehandler differs from capacity of the forks or attachment, the lower value becomes the overall load capacity.

Use the proper capacity chart to determine maximum capacity at various machine configurations. Lifting and placing a load may require use of more than one capacity chart based on machine configuration.

Other than block forks, all forks should be used in matched pairs, block forks used in matched sets.



WARNING

Never use an attachment without the appropriate manufacturer approved capacity chart installed on the telehandler.

Section 5- Attachments and Hitches

5.5 USE OF THE CAPACITY CHART

To properly use capacity chart (see page 5-7), operator must first determine and/or have the following:

1. An approved attachment. See "Approved Attachments" on page 5-1.
2. Proper Capacity Chart(s).
3. Weight of load being lifted.
4. Load placement information:
 - a. HEIGHT where load is to be placed.
 - b. DISTANCE from front tires of telehandler where load is to be placed.
5. On capacity chart, find the line for height and follow it over to distance.
6. Number in load zone where the two cross is the maximum capacity for this lift. If the two cross at a division between zones, the smaller number must be used.

The number in load zone must be equal to or greater than weight of load to be lifted. Determine limits of load zone on capacity chart and keep within these limits.

Capacity Indicator Locations

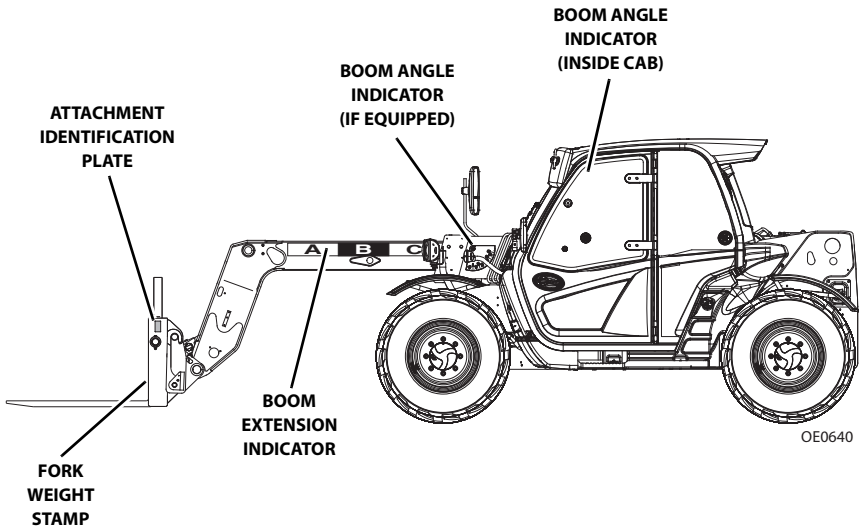

Sample Capacity Chart (CE)

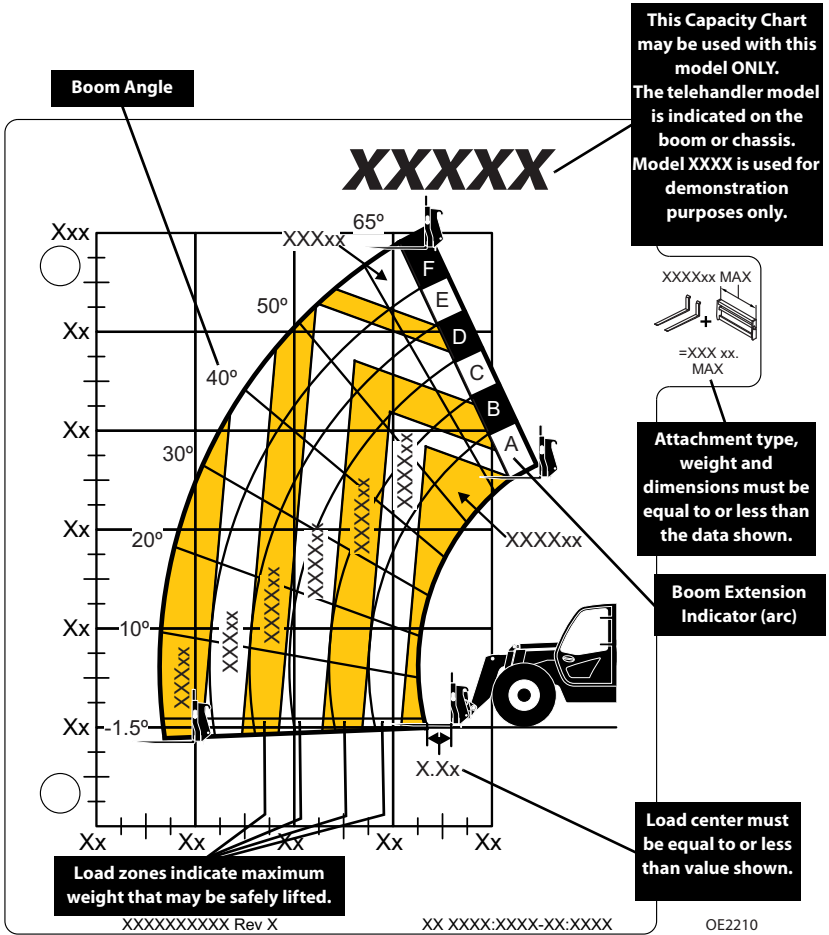

Note: This is sample capacity chart **only!** **DO NOT** use this chart, use the one located in your operator cab.



WARNING

TIP OVER HAZARD. All loads shown on rated capacity chart are based on machine being on firm ground with frame level (see page 4-11 or 4-14); the forks being positioned evenly on carriage; the load being centered on forks; proper size tires being properly inflated; and the telehandler being in good operating condition.

Section 5- Attachments and Hitches

Sample Capacity Chart (AUS)

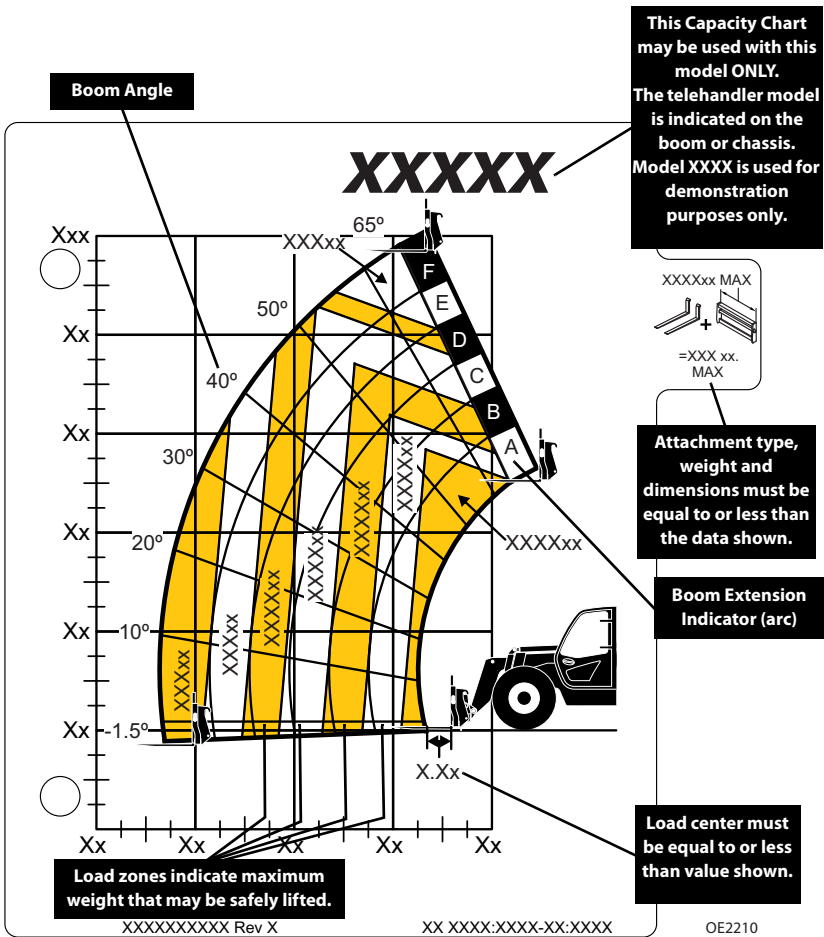

Note: This is sample capacity chart **only!** **DO NOT** use this chart, use the one located in your operator cab.



WARNING

TIP OVER HAZARD. All loads shown on rated capacity chart are based on machine being on firm ground with frame level (see page 4-11 or 4-14); the forks being positioned evenly on carriage; the load being centered on forks; proper size tires being properly inflated; and the telehandler being in good operating condition.

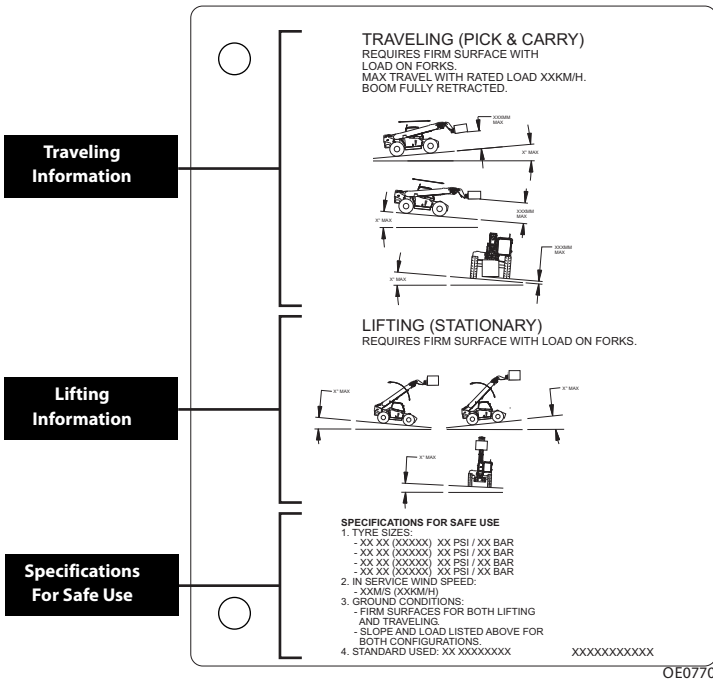

Note: This is a sample capacity chart **only!** **DO NOT** use this chart, use the one located in your operator cab.

Section 5- Attachments and Hitches

Example

A contractor owns a model xxx telehandler with a fork carriage. The contractor knows this attachment may be used with his model since:

- The attachment style, weight, dimensions and load center match the attachment data on the capacity chart.
- The capacity chart is clearly marked for model xxx and corresponds with machine configuration being used.

Below are examples with various conditions the contractor may encounter and whether or not the load may be lifted.

	Load Weight	Distance	Height	OK to Lift
1	1250 kg (2755 lb)	4,0 m (13.1 ft)	3,5 m (11.5 ft)	Yes
2	750 kg (1653 lb)	6,0 m (19.7 ft)	9,0 m (29.5 ft)	NO
3	2500 kg (5512 lb)	2,0 m (6.6 ft)	6,5 m (21.3 ft)	Yes
4	3000 kg (6614 lb)	1,5 m (4.9 ft)	10,5 m (34.4 ft)	NO

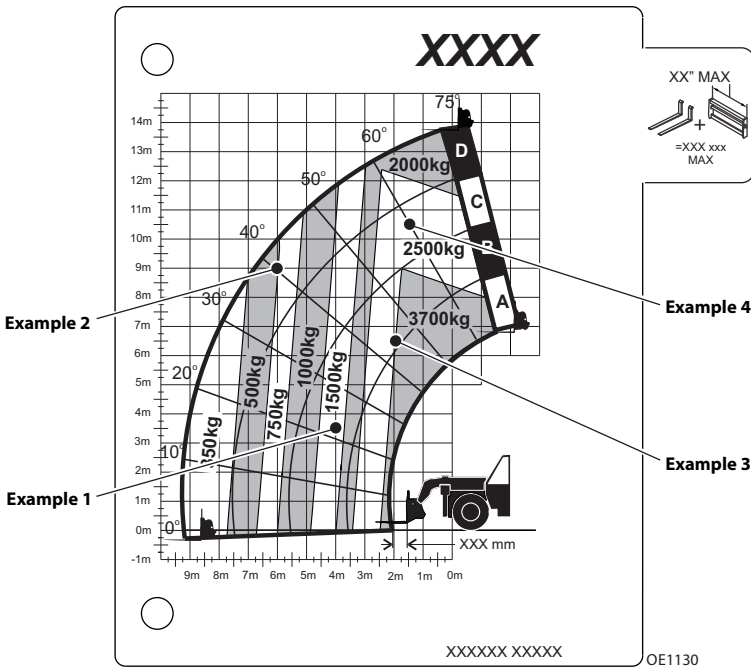

Note: This is a sample capacity chart **only!** **DO NOT** use this chart, use the one located in your operator cab.

5.6 ATTACHMENT INSTALLATION

Coupler

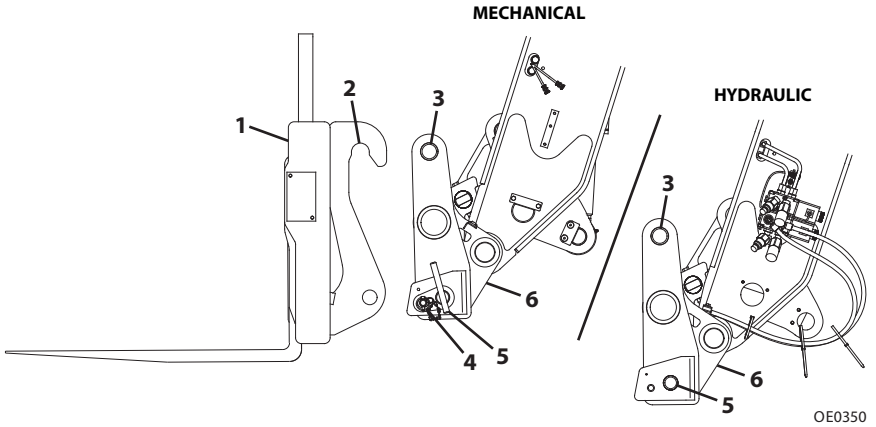

1. **Attachment**
2. **Attachment Pin Recess**
3. **Attachment Pin**
4. **Retainer Pin** (mechanical coupler)
5. **Lock Pin**
6. **Coupler** (attachment tilt control in cab, see page 3-26)



WARNING

CRUSH HAZARD. Always be certain that carriage or attachment is properly positioned on boom and is secured by lock pin and retainer pin. Failure to ensure proper installation could permit carriage/attachment/load to disengage.

Section 5- Attachments and Hitches

Mechanical Coupler

This installation procedure is designed for one-person operation. Prior to exiting cab, perform "Shut-Down Procedure" page 4-6.

1. Tilt coupler forward to provide clearance. Check to be sure lock pin and retainer pin is out.

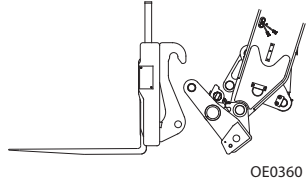

2. Align attachment pin with recess in attachment. Raise boom slightly to engage attachment pin in recess.

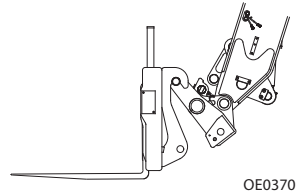

3. Tilt coupler back to engage attachment.

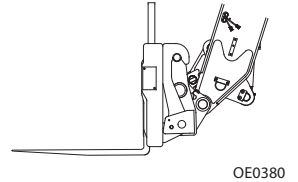

4. Insert lock pin and secure with retainer pin.

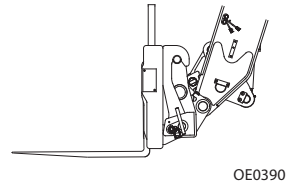

5. If attachment is equipped, connect auxiliary hydraulic hoses. See "JD Coupler" on page 5-14.

Hydraulic Coupler

This installation procedure is designed for one-person operation.

1. Tilt coupler forward to provide clearance. Check to be sure lock pin is disengaged.

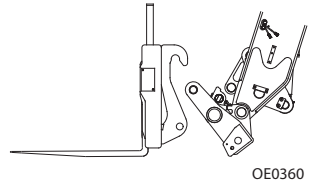

2. Align attachment pin with recess in attachment. Raise boom slightly to engage attachment pin in recess.

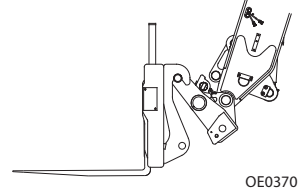

3. Tilt coupler back to engage attachment.

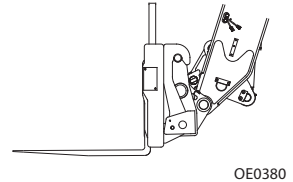

4. Press and hold the coupler switch (1) on left control panel. At the same time, press roller switch (2) up to engage lock pin. Press roller switch (2) down to disengage lock pin.

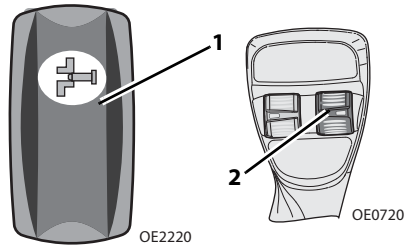

5. Raise boom to eye level and visually check that the lock pin protrudes through the hole. If the pin does not protrude through the hole, place the attachment on the ground and return to step 2.

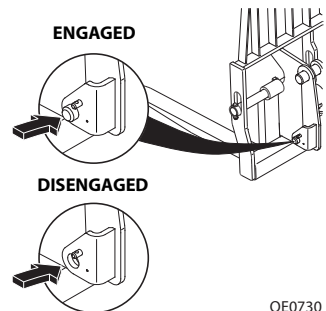

6. If attachment is equipped, connect auxiliary hydraulic hoses. See "JD Coupler" on page 5-14.

Section 5- Attachments and Hitches

JD Coupler

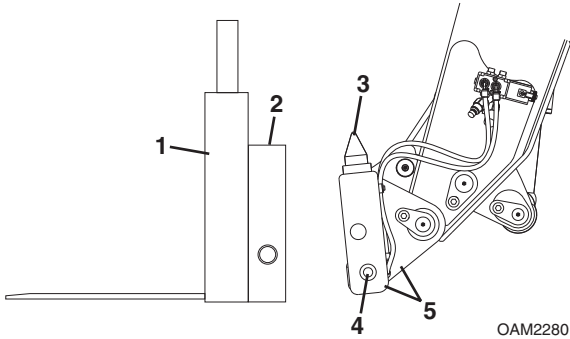

1. **Attachment**
2. **Attachment Point Opening**
3. **Coupler Point**
4. **Lock Pin**
5. **JD Coupler** (attachment tilt control in cab, see page 3-26)



WARNING

CRUSH HAZARD. Always be certain that carriage or attachment is properly positioned on boom and is secured by lock pin. Failure to ensure proper installation could permit carriage/attachment/load to disengage.

Section 5- Attachments and Hitches

This installation procedure is designed for one-person operation.

1. Tilt coupler forward to provide clearance. Check to be sure lock pin is disengaged.

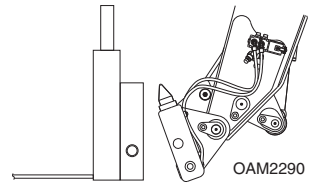

2. Align coupler point with opening in attachment. Raise boom slightly to engage coupler point in opening.

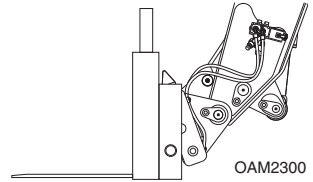

3. Tilt coupler back to engage attachment.

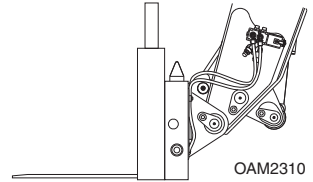

4. Press and hold the coupler switch (1) on left control panel. At the same time, press roller switch (2) up to engage lock pin. Press roller switch (2) down to disengage lock pin.

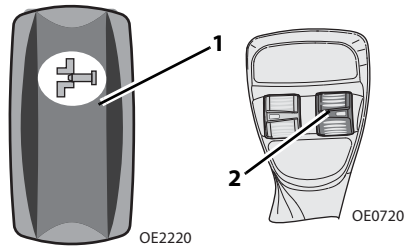

5. Raise boom to eye level and visually check that the lock pin protrudes through the attachment hole. If the pin does not protrude through the attachment hole, place the attachment on the ground and return to step 2.
6. If attachment is equipped, connect auxiliary hydraulic hoses. See "Hydraulic Operated Attachment" on page 5-20.

Section 5- Attachments and Hitches

Manitou Coupler

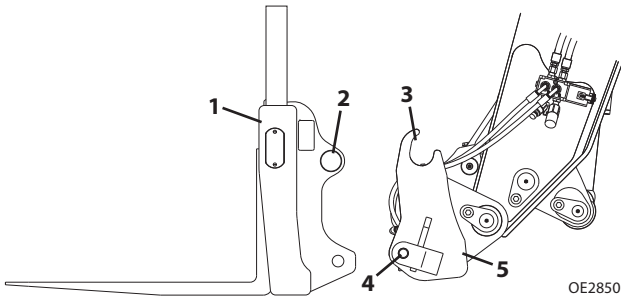

OE2850

1. **Attachment**
2. **Attachment Pin**
3. **Attachment Pin Recess**
4. **Lock Pin**
5. **Manitou Coupler** (attachment tilt control in cab, see page 3-26)



WARNING

CRUSH HAZARD. Always be certain that carriage or attachment is properly positioned on boom and is secured by lock pin. Failure to ensure proper installation could permit carriage/attachment/load to disengage.

Section 5- Attachments and Hitches

This installation procedure is designed for one-person operation.

1. Tilt coupler forward to provide clearance. Check to be sure lock pin is disengaged.

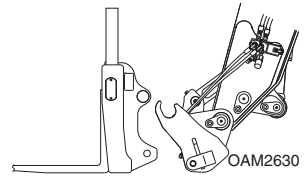

2. Align attachment pin recess with attachment pin. Raise boom slightly to engage attachment pin in recess.

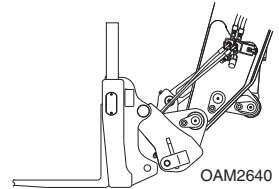

3. Tilt coupler back to engage attachment.

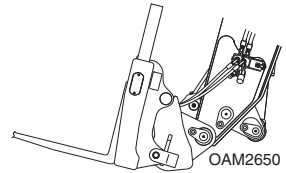

4. Press and hold the coupler switch (1) on left control panel. At the same time, press roller switch (2) up to engage lock pin. Press roller switch (2) down to disengage lock pin.

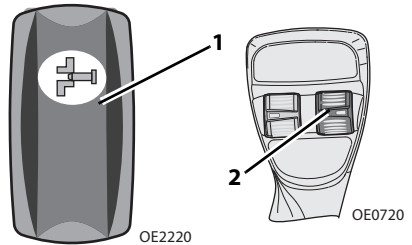

5. Raise boom to eye level and visually check that the lock pin protrudes through the attachment hole. If the pin does not protrude through the attachment hole, place the attachment on the ground and return to step 2.
6. If attachment is equipped, connect auxiliary hydraulic hoses. See "Hydraulic Operated Attachment" on page 5-20.

Section 5- Attachments and Hitches

JCB Coupler

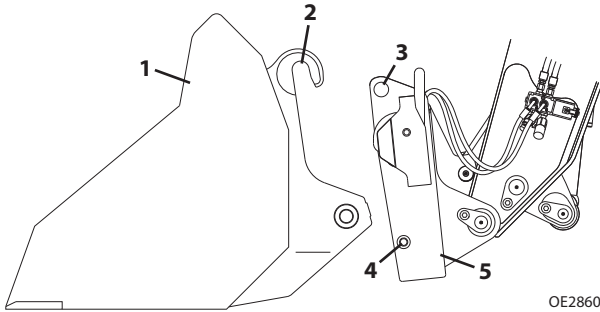

OE2860

1. **Attachment**
2. **Attachment Pin Recess**
3. **Attachment Pin**
4. **Lock Pin**
5. **JCB Coupler** (attachment tilt control in cab, see page 3-26)



WARNING

CRUSH HAZARD. Always be certain that carriage or attachment is properly positioned on boom and is secured by lock pin. Failure to ensure proper installation could permit carriage/attachment/load to disengage.

Section 5- Attachments and Hitches

This installation procedure is designed for one-person operation.

1. Tilt coupler forward to provide clearance. Check to be sure lock pin is disengaged.

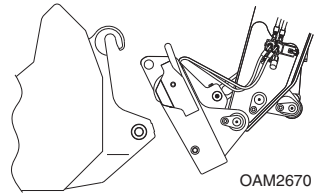

2. Align attachment pin with recess in attachment. Raise boom slightly to engage attachment pin in recess.

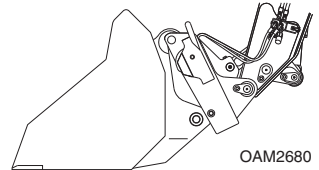

3. Tilt coupler back to engage attachment.

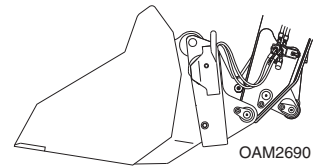

4. Press and hold the coupler switch (1) on left control panel. At the same time, press roller switch (2) up to engage lock pin. Press roller switch (2) down to disengage lock pin.

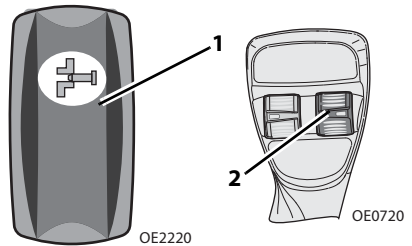

5. Raise boom to eye level and visually check that the lock pin protrudes through the attachment hole. If the pin does not protrude through the attachment hole, place the attachment on the ground and return to step 2.
6. If attachment is equipped, connect auxiliary hydraulic hoses. See "Hydraulic Operated Attachment" on page 5-20.

Section 5- Attachments and Hitches

Hydraulic Operated Attachment

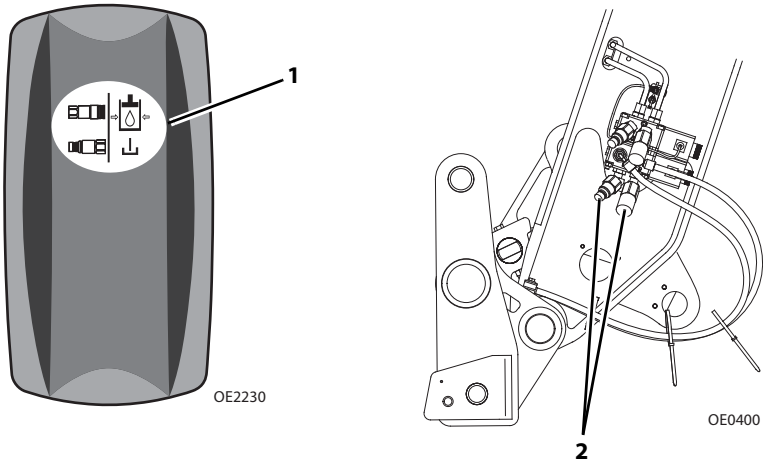

1. Install attachment (see page 5-11).
2. Lower attachment to ground.
3. Press and hold auxiliary decompression switch (1) on right control panel for three seconds to relieve pressure at both auxiliary fittings (2).
4. Perform "Shut-Down Procedure" on page 4-6.
5. Connect attachment hoses to both auxiliary fittings.

5.7 ADJUSTING/MOVING FORKS

Carriages may have different locations where forks can be positioned. Two different methods can be used for repositioning, depending upon carriage structure.

Note: *Apply a light coating of appropriate lubricant to ease sliding of forks or fork bar.*

To slide forks:

1. Ensure attachment is properly installed. See "Attachment Installation" on page 5-11.
2. If equipped, loosen fork locking bolt.
3. Elevate attachment to approximately 1,5 m (5 ft) and tilt carriage forward until fork heel is free from attachment.
4. Stand at side of carriage. To slide fork toward center of carriage, push fork near fork eye. To slide fork toward edge of carriage, pull fork near fork eye. To avoid pinching, do not place fingers or thumb between fork and carriage structure.
5. If equipped, tighten fork locking bolt.

If removing fork bar is necessary:

1. Rest forks on ground.
2. If equipped, loosen fork locking bolt.
3. Remove fork bar.
4. Reposition forks.
5. Reinstall the fork bar and fork bar retaining mechanism(s).
6. If equipped, tighten fork locking bolt.

Section 5- Attachments and Hitches

5.8 ATTACHMENT OPERATION

- Capacities and range limits for telehandler change depending on attachment in use.
- Separate attachment instructions must be kept in manual holder in cab with this Operation & Maintenance Manual. An additional copy must be kept with attachment if it is equipped with a manual holder.

Note: Operations described within this section reference the Lift joystick pattern. Refer to page 3-30 if utilizing the Loader joystick pattern.

NOTICE

EQUIPMENT DAMAGE. Some attachments may contact front tires or machine structure when the boom is retracted and the attachment is rotated. Improper use of attachment may result in attachment or machine structural damage.

NOTICE

EQUIPMENT DAMAGE. Avoid contact with any structure or object when lifting a load. Maintain clearance around boom structure and load. Failure to maintain clearance may result in attachment or machine structural damage.

Carriage with Forks

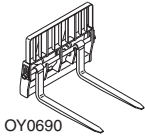

Use Carriage Attachment Capacity Chart

To determine maximum capacity, refer to "Telehandler/Attachment/Fork Capacity" on page 5-5.

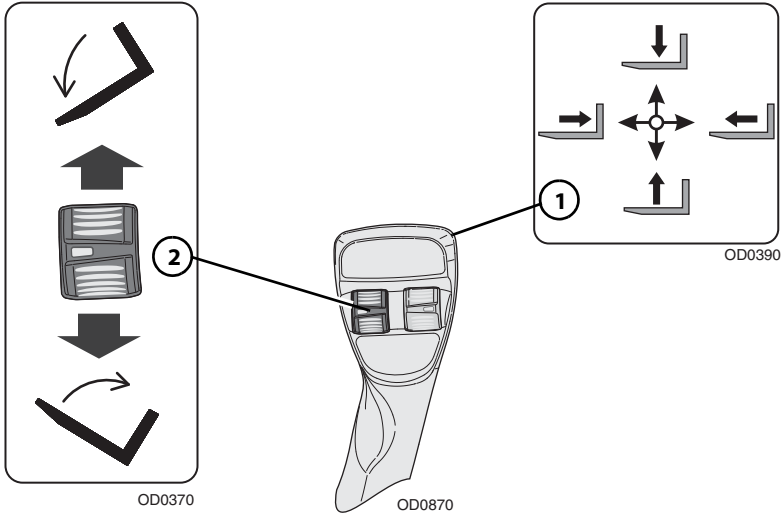

Joystick (1) controls movement of the boom.

Roller switch (2) controls carriage tilt.

- Press roller switch down to tilt up.
- Press roller switch up to tilt down.

Installation Procedure:

Refer to "Attachment Installation" on page 5-11.

Equipment Damage Precautions:

- Do not use forks as a lever to pry material. Excessive prying forces could damage forks or machine structure.
- Do not attempt to lift loads that are attached or connected to another object.

Section 5- Attachments and Hitches

Fork Positioning Carriage

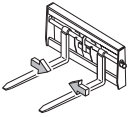

OZ3670

Use Fork Positioning Carriage Capacity Chart

To determine maximum capacity, refer to "Telehandler/Attachment/
Fork Capacity" on page 5-5.

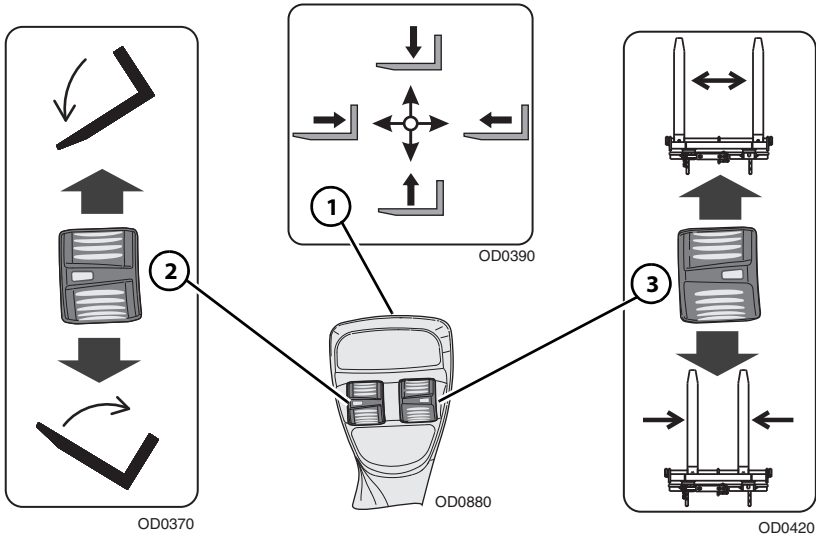

Joystick (1) controls movement of the boom.

Roller switch (2) controls carriage tilt.

- Press roller switch down to tilt up.
- Press roller switch up to tilt down.

To Fork Position:

Roller switch (3) controls fork position.

- Press roller switch down to shift forks in.
- Press roller switch up to shift forks out.

Installation Procedure:

- Refer to “Attachment Installation” on page 5-11.



WARNING

CRUSH HAZARD. Do not use rotation to push or pull objects or load. Failure to comply could cause object or load to fall.

Equipment Damage Precautions

- Do not use forks as a lever to pry material. Excessive prying forces could damage forks or machine structure.
- Do not attempt to lift loads that are attached or connected to another object.

Section 5- Attachments and Hitches

Side Tilt Carriage and Fork Rotator Carriage

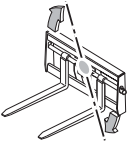

OAL1550

Use Appropriate Side Tilt Carriage or Fork Rotator Carriage Capacity Chart

To determine maximum capacity, refer to *“Telehandler/Attachment/Fork Capacity”* on page 5-5.

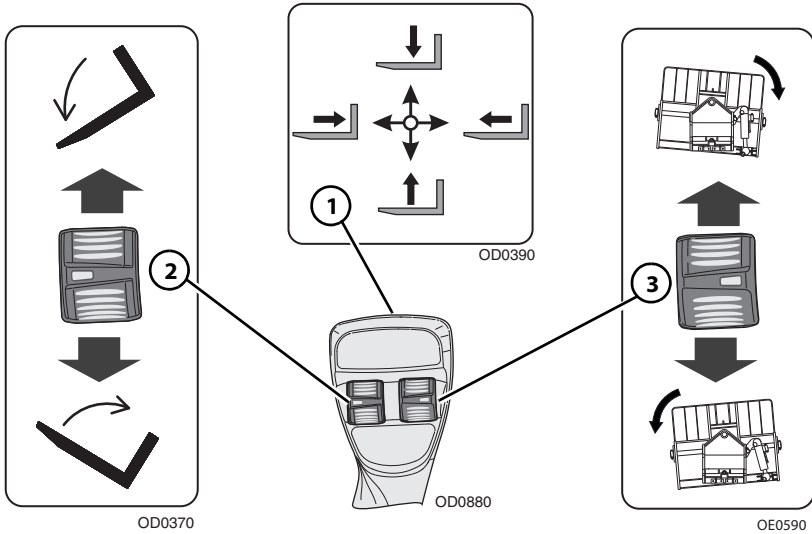

Joystick (1) controls movement of the boom.

Roller switch (2) controls carriage tilt.

- Press roller switch down to tilt up.
- Press roller switch up to tilt down.

To Rotate:

Roller switch (3) controls carriage rotation.

- Press roller switch down to rotate left.
- Press roller switch up to rotate right.

Installation Procedure:

- Refer to “Attachment Installation” on page 5-11.



WARNING

CRUSH HAZARD. Do not use rotation to push or pull objects or load. Failure to comply could cause object or load to fall.

Equipment Damage Precautions

- Do not use forks as a lever to pry material. Excessive prying forces could damage forks or machine structure.
- Do not attempt to lift loads that are attached or connected to another object.

Section 5- Attachments and Hitches

Side Shift Carriage

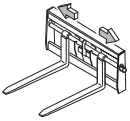

OAL1540

Use Side Shift Carriage Capacity Chart

To determine maximum capacity, refer to "Telehandler/Attachment/Fork Capacity" on page 5-5.

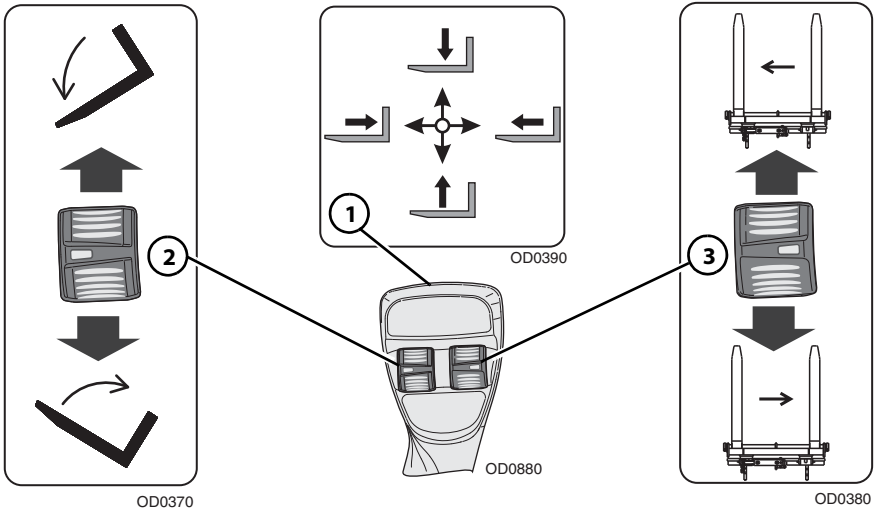

Joystick (1) controls movement of the boom.

Roller switch (2) controls carriage tilt.

- Press roller switch down to tilt up.
- Press roller switch up to tilt down.

To Side Shift:

Roller switch (3) controls carriage side shift.

- Press roller switch down to shift forks right.
- Press roller switch up to shift forks left.

Installation Procedure:

- Refer to “Attachment Installation” on page 5-11.



WARNING

CRUSH HAZARD. Do not use side shift to push or pull objects or load. Failure to comply could cause object or load to fall.

Equipment Damage Precautions:

- Do not use forks as a lever to pry material. Excessive prying forces could damage forks or machine structure.
- Do not attempt to lift loads that are attached or connected to another object.

Section 5- Attachments and Hitches

Fork Extension

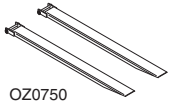

OZ0750

Use Appropriate Carriage Attachment Capacity Chart

To determine maximum capacity, refer to *“Telehandler/Attachment/Fork Capacity”* on page 5-5. The maximum capacity of the carriage when equipped with fork extensions may be reduced to the capacity indicated on the fork extensions. If the load exceeds the capacity of the fork extension, contact the local Caterpillar dealer to obtain forks and/or fork extensions of the proper load rating and length.

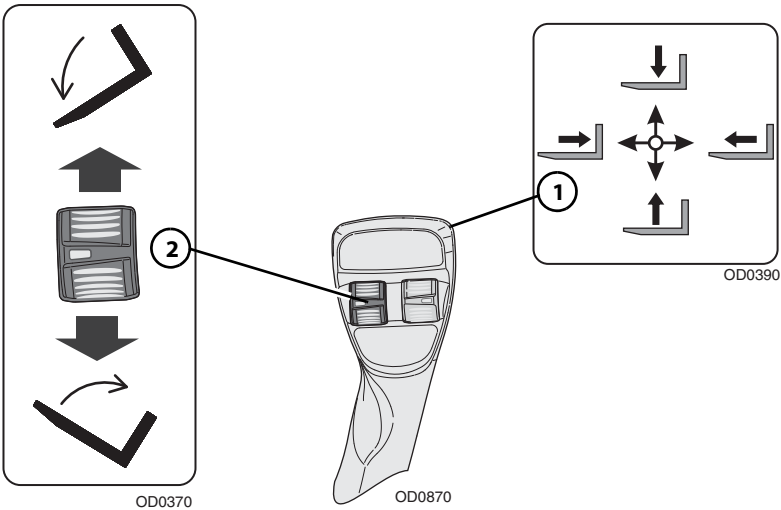

Joystick (1) controls movement of the boom.

Roller switch (2) controls carriage tilt.

- Press roller switch down to tilt up.
- Press roller switch up to tilt down.

Installation Procedure:

- Ensure carriage is properly installed. Refer to *"Attachment Installation"* on page 5-11.
- Ensure length and cross section of the parent fork arm is equal to or exceeds the parent fork arm blade length stamped into the fork extension.
- Secure the fork extensions to the forks by sliding the fork extensions onto the parent forks and install the retaining pin behind the vertical shank of the fork.

Operation:

- Heavy part of load must be against carriage backrest.
- Do not allow load center of gravity to be in front of tip of the supporting fork.
- Do not pick up a load or pry materials with tip of fork extensions.

Section 5- Attachments and Hitches

Pipe Grapple



Use Pipe Grapple Attachment Capacity Chart

To determine maximum capacity, refer to "Telehandler/Attachment/Fork Capacity" on page 5-5.

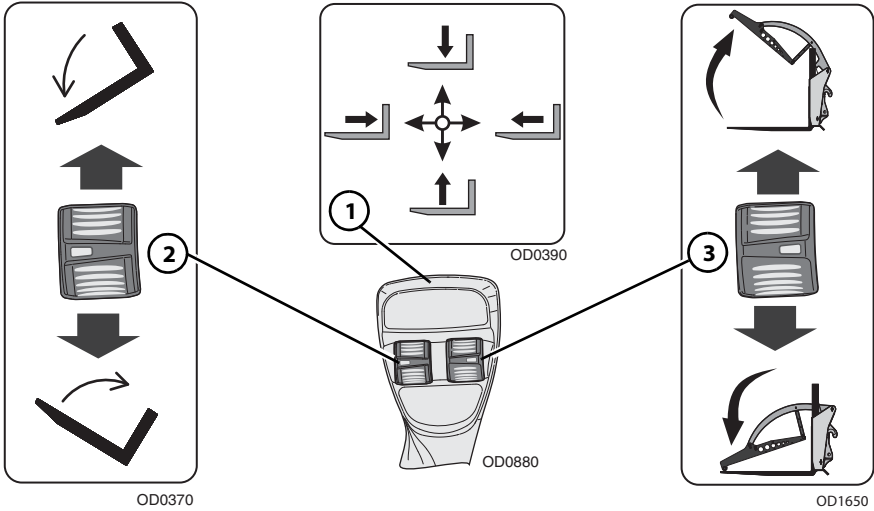

Joystick (1) controls movement of the boom.

Roller switch (2) controls pipe grapple tilt.

- Press roller switch down to tilt up.
- Press roller switch up to tilt down.

To Open/Close Pipe Grapple:

Roller switch (3) controls the open/close movement of the pipe grapple.

- Press roller switch down to close grapple.
- Press roller switch up to open grapple.

Installation Procedure:

- Refer to “Attachment Installation” on page 5-11.

Operation:

- Raise or lower boom to appropriate height and open pipe grapple for loading material.
- Align and center telehandler with face of material.
- Drive slowly and smoothly into material for loading. Boom extension may be required for loading material.
- Center load on forks, tilt forks up far enough to retain load, close pipe grapple and back away.
- Travel in accordance with requirements set forth in Section 1- General Safety Practices.
- Open pipe grapple and unload material from forks.

Equipment Damage Precautions

- Except for lifting or unloading material, the boom must be fully retracted for all operations.
- Do not use forks as a lever to pry material. Excessive prying forces could damage forks or machine structure.
- Do not use pipe grapple as a lever to pry material. Excessive prying forces could damage pipe grapple or machine structure.
- Do not attempt to load material which is hard or frozen. This could cause severe damage to coupler or machine structure.
- Do not attempt to lift loads that are attached or connected to another object.

Section 5- Attachments and Hitches

Dual Tine Bale

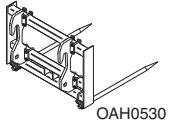

Use Dual Tine Bale Capacity Chart

To determine maximum capacity, refer to "Telehandler/Attachment/Fork Capacity" on page 5-5.

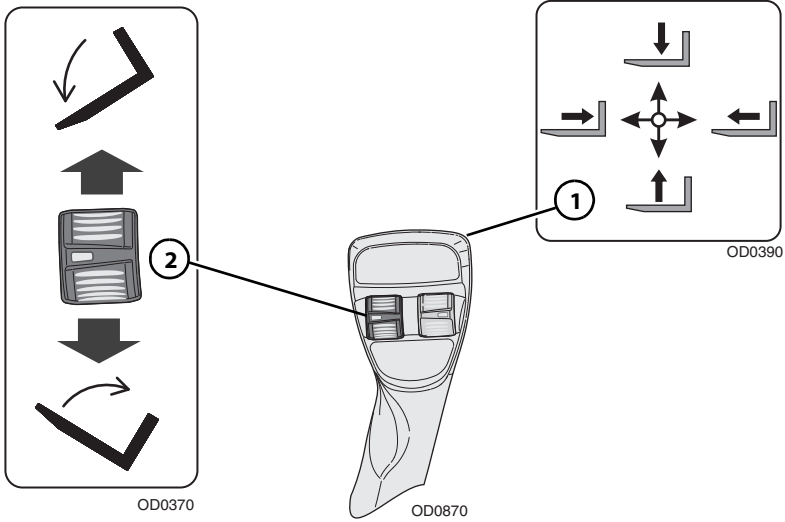

Joystick (1) controls movement of the boom.

Roller switch (2) controls carriage tilt.

- Press roller switch down to tilt up.
- Press roller switch up to tilt down.

Installation Procedure:

Refer to "Attachment Installation" on page 5-11.

Equipment Damage Precautions:

- Do not use forks as a lever to pry material. Excessive prying forces could damage forks or machine structure.
- Do not attempt to lift loads that are attached or connected to another object.

This Page Intentionally Left Blank

Section 5- Attachments and Hitches

Bale Handler

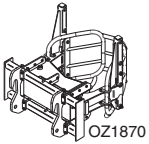

Use Bale Handler Capacity Chart

To determine maximum capacity, refer to "Telehandler/Attachment/
Fork Capacity" on page 5-5.

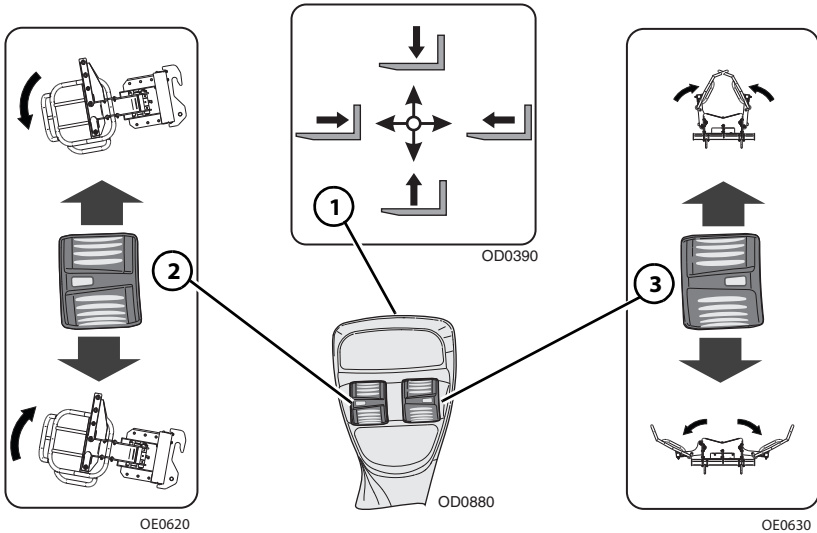

Joystick (1) controls movement of the boom.

Roller switch (2) controls bale handler tilt.

- Press roller switch down to tilt up.
- Press roller switch up to tilt down.

To Open/Close Bale Handler:

Roller switch (3) controls open/close movement of the bale handler.

- Press roller switch down to open bale handler.
- Press roller switch up to close bale handler.

Installation Procedure:

Refer to *"Attachment Installation"* on page 5-11.

Operation:

- Travel in accordance with requirements set forth in Section 1- General Safety Practices.

Equipment Damage Precautions

- Do not use bale handler as a lever to pry material. Excessive prying forces could damage the bale handler or machine structure.
- Do not attempt to load material which is hard or frozen. This could cause severe damage to coupler or machine structure.

Section 5- Attachments and Hitches

Bucket

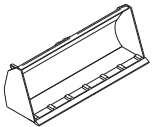

OZ0730

Use Appropriate Bucket Capacity Chart

To determine maximum capacity, refer to "Telehandler/Attachment/
Fork Capacity" on page 5-5.

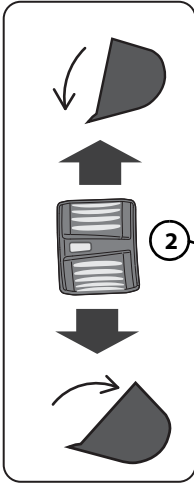

OD0460

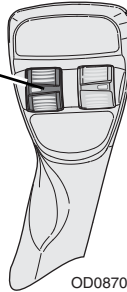

OD0870

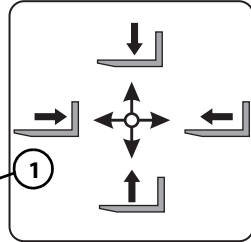

OD0390

Joystick (1) controls movement of the boom.

Roller switch (2) controls bucket tilt.

- Press roller switch down to tilt up.
- Press roller switch up to tilt down.

Installation Procedure:

- Refer to "Attachment Installation" on page 5-11.

Operation:

- Raise or lower boom to appropriate height for loading material from stockpile.
- Align telehandler with face of stockpile and drive slowly and smoothly into pile to load bucket.
- Tilt bucket up far enough to retain load and back away from pile.
- Travel in accordance with requirements set forth in Section 1- General Safety Practices.
- Tilt bucket down to dump load.

Equipment Damage Precautions

- Except for lifting or dumping a load, the boom must be fully retracted for all bucket operations.
- Do not corner-load bucket. Distribute material evenly within the bucket. Bucket capacity charts are for evenly distributed loads only.
- Do not use bucket as a lever to pry material. Excessive prying forces could damage bucket or machine structure.
- Do not attempt to load material which is hard or frozen. This could cause severe damage to coupler or machine structure.
- Do not use bucket for "back dragging." This could cause severe damage to coupler and retraction cables/chains.

Section 5- Attachments and Hitches

Multi-Purpose Bucket

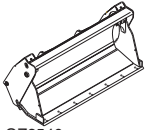

OZ2540

Use Appropriate Multi-Purpose Bucket Capacity Chart

To determine maximum capacity, refer to "Telehandler/Attachment/
Fork Capacity" on page 5-5.

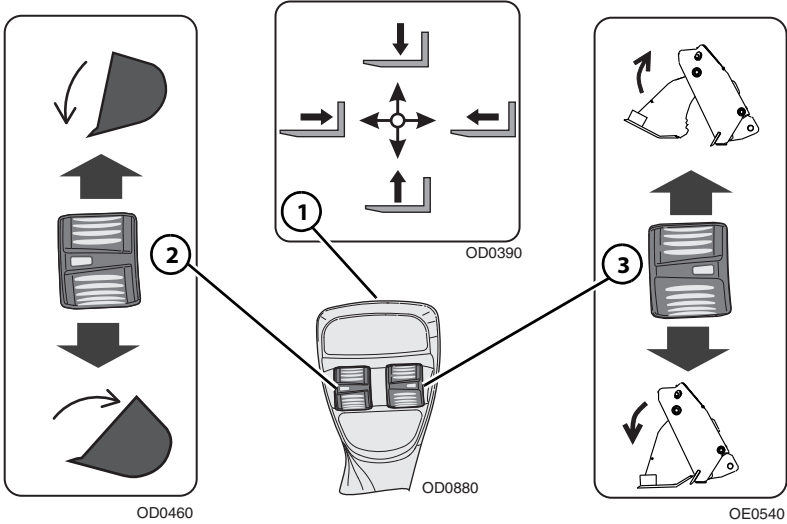

Joystick (1) controls movement of the boom.

Roller switch (2) controls bucket tilt.

- Press roller switch down to tilt up.
- Press roller switch up to tilt down.

To Open/Close Bucket:

The attachment auxiliary hydraulic roller switch (3) controls open/close movement of the bucket.

- Press roller switch down to close bucket.
- Press roller switch up to open bucket.

Installation Procedure:

- Refer to “Attachment Installation” on page 5-11.

Operation:

- Raise or lower boom to appropriate height and close bucket for loading material from stockpile.
- Align telehandler with face of stockpile and drive slowly and smoothly into pile to load bucket.
- Tilt bucket up far enough to retain load and back away from pile.
- Travel in accordance with requirements set forth in Section 1- General Safety Practices.
- Open bucket or tilt bucket down to dump load.

Equipment Damage Precautions

- Except for lifting or dumping a load, the boom must be fully retracted for all bucket operations.
- Do not corner-load bucket. Distribute material evenly within the bucket. Bucket capacity charts are for evenly distributed loads only.
- Do not use bucket as a lever to pry material. Excessive prying forces could damage bucket or machine structure.
- Do not attempt to load material which is hard or frozen. This could cause severe damage to coupler or machine structure.
- Do not use bucket for "back dragging." This could cause severe damage to coupler.

Section 5- Attachments and Hitches

Grapple Bucket

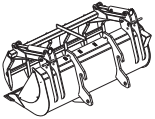

OZ1450

Use Grapple Bucket Capacity Chart

To determine maximum capacity, refer to "Telehandler/Attachment/Fork Capacity" on page 5-5.

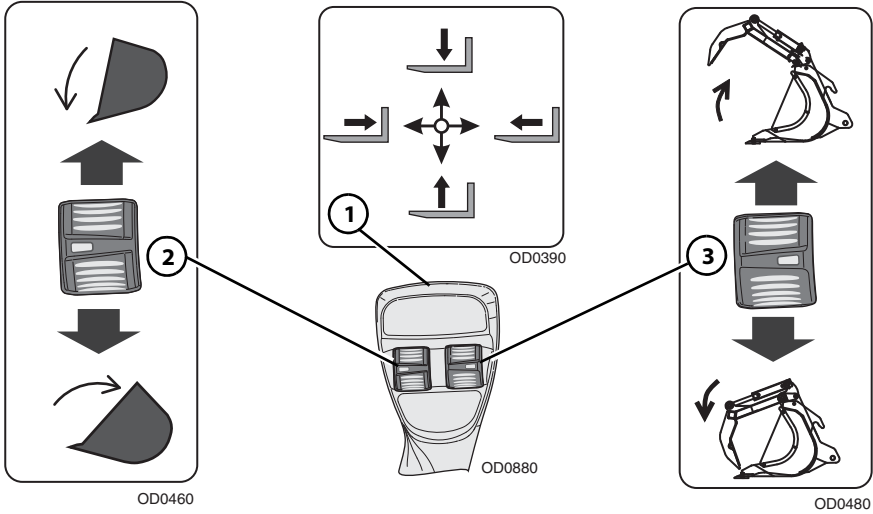

Joystick (1) controls movement of the boom.

Roller switch (2) controls grapple bucket tilt.

- Press roller switch down to tilt up.
- Press roller switch up to tilt down.

To Open/Close Grapple:

Roller switch (3) controls the open/close movement of the grapple.

- Press roller switch down to close grapple.
- Press roller switch up to open grapple.

Installation Procedure:

- Refer to “Attachment Installation” on page 5-11.

Operation:

- Raise or lower boom to appropriate height and open grapple for loading material from stockpile.
- Align telehandler with face of stockpile and drive slowly and smoothly into pile to load bucket.
- Tilt bucket up far enough to retain load, close grapple and back away from pile.
- Travel in accordance with requirements set forth in Section 1- General Safety Practices.
- Open grapple and tilt bucket down to dump load.

Equipment Damage Precautions

- Except for lifting or dumping a load, the boom must be fully retracted for all bucket operations.
- Do not corner-load bucket. Distribute material evenly within the bucket. Bucket capacity charts are for evenly distributed loads only.
- Do not use bucket as a lever to pry material. Excessive prying forces could damage bucket or machine structure.
- Do not attempt to load material which is hard or frozen. This could cause severe damage to coupler or machine structure.
- Do not use bucket for "back dragging." This could cause severe damage to coupler and retraction cables/chains.

Section 5- Attachments and Hitches

Manure Grapple

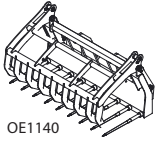

Use Manure Grapple Capacity Chart

To determine maximum capacity, refer to "Telehandler/Attachment/Fork Capacity" on page 5-5.

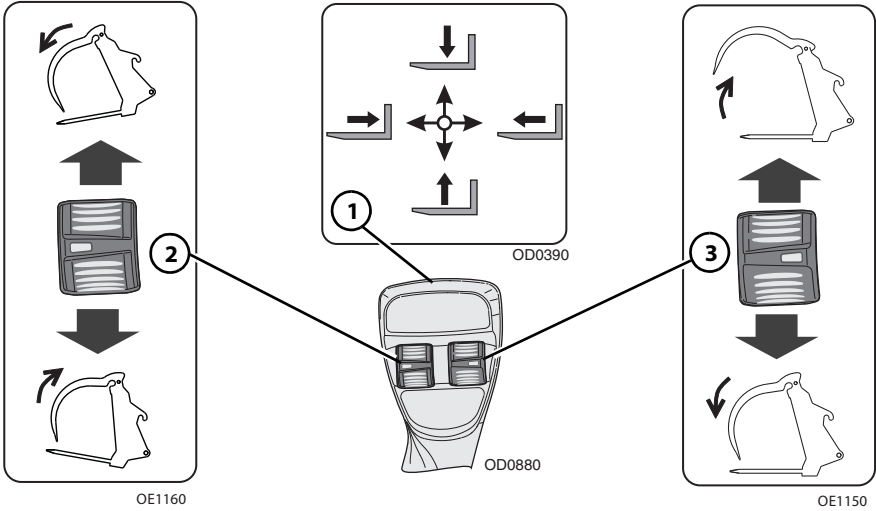

Joystick (1) controls movement of the boom.

Roller switch (2) controls manure grapple tilt.

- Press roller switch down to tilt up.
- Press roller switch up to tilt down.

To Open/Close Manure Grapple:

Roller switch (3) controls the open/close movement of the manure grapple.

- Press roller switch down to close grapple.
- Press roller switch up to open grapple.

Installation Procedure:

- Refer to “Attachment Installation” on page 5-11.

Operation:

- Raise or lower boom to appropriate height and open manure grapple for loading material from stockpile.
- Align telehandler with face of stockpile and drive slowly and smoothly into pile to load manure grapple.
- Tilt manure grapple up far enough to retain load, close manure grapple and back away from pile.
- Travel in accordance with requirements set forth in Section 1- General Safety Practices.
- Open manure grapple and tilt down to dump load.

Equipment Damage Precautions

- Except for lifting or dumping a load, the boom must be fully retracted for all operations.
- Do not corner-load manure grapple. Distribute material evenly within the manure grapple. Manure grapple capacity charts are for evenly distributed loads only.
- Do not use manure grapple as a lever to pry material. Excessive prying forces could damage manure grapple or machine structure.
- Do not attempt to load material which is hard or frozen. This could cause severe damage to coupler or machine structure.
- Do not use manure grapple for "back dragging." This could cause severe damage to coupler and retraction cables/chains.

Section 5- Attachments and Hitches

Muck Fork

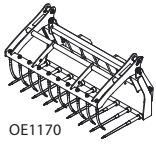

Use Muck Fork Capacity Chart

To determine maximum capacity, refer to "Telehandler/Attachment/
Fork Capacity" on page 5-5.

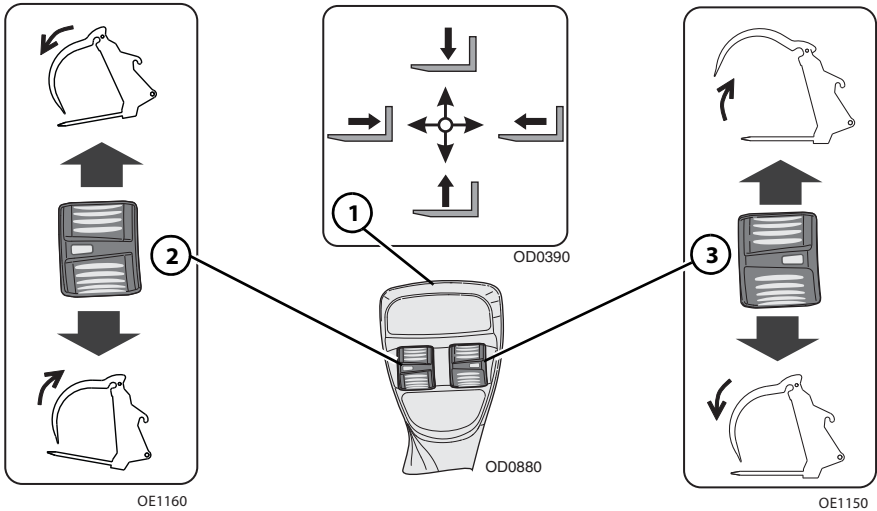

Joystick (1) controls movement of the boom.

Roller switch (2) controls muck fork tilt.

- Press roller switch down to tilt up.
- Press roller switch up to tilt down.

To Open/Close Muck Fork:

Roller switch (3) controls the open/close movement of the muck fork.

- Press roller switch down to close muck fork.
- Press roller switch up to open muck fork.

Installation Procedure:

- Refer to “Attachment Installation” on page 5-11.

Operation:

- Raise or lower boom to appropriate height and open muck fork for loading material from stockpile.
- Align telehandler with face of stockpile and drive slowly and smoothly into pile to load muck fork.
- Tilt muck fork up far enough to retain load, close muck fork and back away from pile.
- Travel in accordance with requirements set forth in Section 1- General Safety Practices.
- Open muck fork and tilt down to dump load.

Equipment Damage Precautions

- Except for lifting or dumping a load, the boom must be fully retracted for all operations.
- Do not corner-load muck fork. Distribute material evenly within the muck fork. Muck fork capacity charts are for evenly distributed loads only.
- Do not use muck fork as a lever to pry material. Excessive prying forces could damage muck fork or machine structure.
- Do not attempt to load material which is hard or frozen. This could cause severe damage to coupler or machine structure.
- Do not use muck fork for "back dragging." This could cause severe damage to coupler and retraction cables/chains.

Section 5- Attachments and Hitches

Sweeper

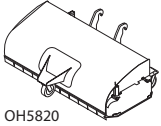

OH5820

Use Sweeper Capacity Chart

To determine maximum capacity, refer to "Telehandler/Attachment/Fork Capacity" on page 5-5.

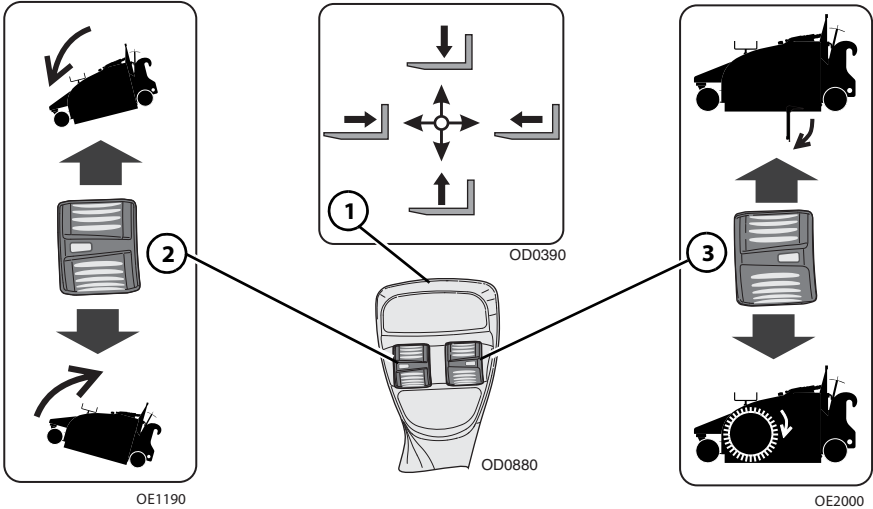

Joystick (1) controls movement of the boom.

Roller switch (2) controls sweeper tilt.

- Press roller switch down to tilt up.
- Press roller switch up to tilt down.

To Control Sweeper:

Roller switch (3) controls the sweeper.

- Press roller switch down to close hopper and engage sweeper brushes.
- Press roller switch up to open hopper.

To Enable/Disable Continuous Operation of Sweeper Brushes:

- With transmission in neutral, press and hold continuous auxiliary hydraulics switch on left dash control panel.
- Press roller switch (3) down to engage sweeper brushes.
- Release continuous auxiliary hydraulics switch and roller switch (3) to enable continuous operation of sweeper brushes.
- To disable continuous operation of sweeper brushes, press continuous auxiliary hydraulics switch again.

Installation Procedure:

- Refer to "Attachment Installation" on page 5-11.



WARNING

CRUSH HAZARD. Remove large objects in path of sweeper before operating. Failure to comply could cause object to be thrown by sweeper.

Operation:

- Place sweeper on a level area. Fully retract boom and lower until all three sweeper wheels are in contact with the ground.
- Using height and angle gauge on the sweeper, obtain the central mid-float position to obtain best sweeping operation.
- Operate roller switch (3) to engage sweeper brushes.
- Sweep a path less than the width of the sweeper.
- Travel in accordance with requirements set forth in Section 1- General Safety Practices.
- To empty hopper, raise sweeper over desired dump area ensuring proper clearance. Operate roller switch (3) to open the hopper allowing the contents to slide out. Close the hopper after all contents are removed.

Equipment Damage Precautions

- Except for emptying hopper, the boom must be fully retracted for all sweeper operations.
- Avoid excessive downward pressure on brushes when sweeping.
- Do not store sweeper with weight on brushes. Place on blocks or storage stands.

Section 5- Attachments and Hitches

Auger

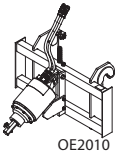

Use Auger Capacity Chart

To determine maximum capacity, refer to "Telehandler/Attachment/Fork Capacity" on page 5-5.

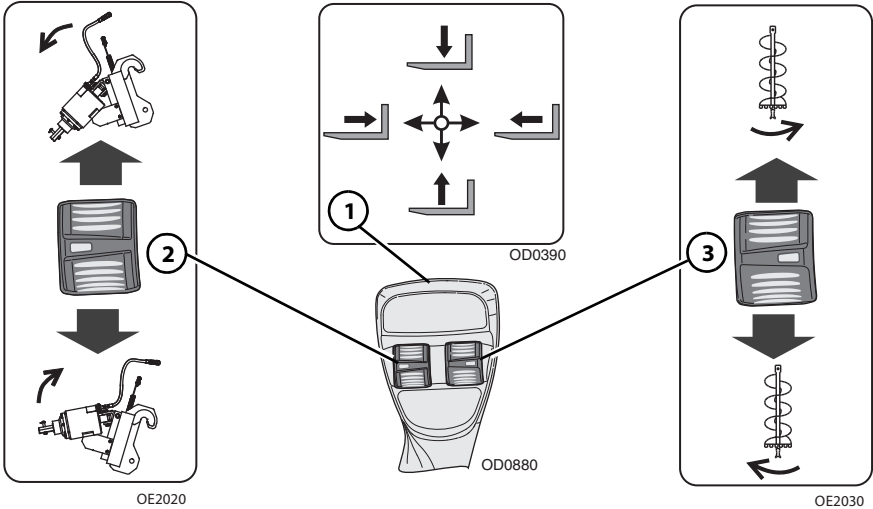

Joystick (1) controls movement of the boom.

Roller switch (2) controls auger tilt.

- Press roller switch down to tilt up.
- Press roller switch up to tilt down.

To Control Auger Bit:

Roller switch (3) controls the auger bit rotation.

- Press roller switch down to rotate clockwise.
- Press roller switch up to rotate counter-clockwise.

Installation Procedure:

- Refer to “Attachment Installation” on page 5-11.

Operation:

- Travel in accordance with requirements set forth in Section 1- General Safety Practices.
- Tilt auger down so auger bit is perpendicular to ground and carriage is horizontal.
- Lower auger to ground so that only the center point penetrates ground.
- Operate roller switch (3) to turn auger in a clockwise ("digging") rotation.
- Release roller switch (3) to stop auger rotation.
- Raise auger from hole to clean out debris.

Equipment Damage Precautions

- Travel with the auger in a safe transport position to prevent uncontrolled movement.
- Transport the auger unit as low as practical at a slow speed without rapid side to side movement.
- Do not engage auger rotation unless the point of the auger cutting head is touching the ground.

Section 5- Attachments and Hitches

Concrete Bucket Mixer

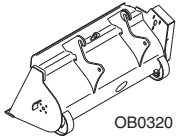

Use Concrete Bucket Mixer Capacity Chart

To determine maximum capacity, refer to "Telehandler/Attachment/Fork Capacity" on page 5-5.

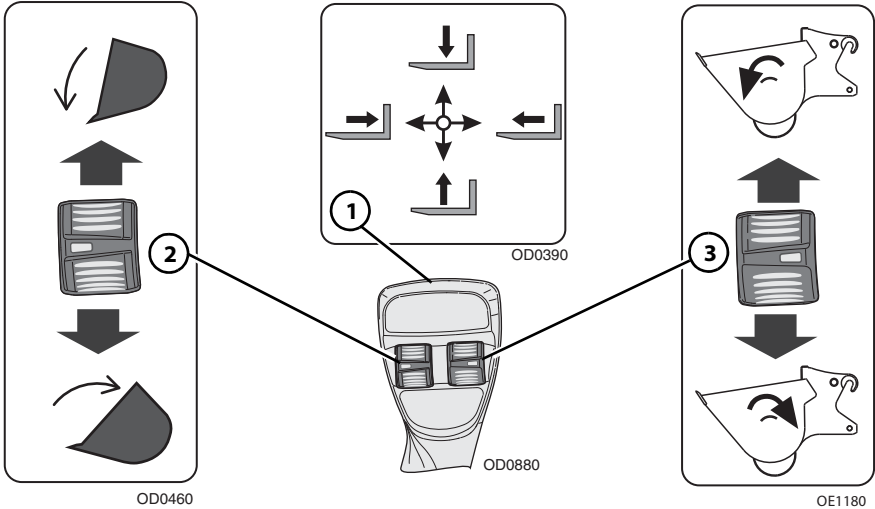

Joystick (1) controls movement of the boom.

Roller switch (2) controls bucket tilt.

- Press roller switch down to tilt up.
- Press roller switch up to tilt down.

To Control Mixer:

Roller switch (3) controls the bucket mixer.

- Press roller switch down to rotate rearward.
- Press roller switch up to rotate forward.

Installation Procedure:

- Refer to “Attachment Installation” on page 5-11.

Operation:

- Close bucket gate, level bucket and fully retract and lower boom to load material.
- Distribute material evenly within the bucket. Bucket capacity charts are for evenly distributed loads only.
- Load center will vary depending on the amount of material in the bucket. Always ensure compliance with the capacity chart.
- Travel in accordance with requirements set forth in Section 1- General Safety Practices.
- Position bucket and open bucket gate to release load.

Equipment Damage Precautions

- Transport the concrete bucket as low as practical at a slow speed and without rapid side to side movement.

Section 5- Attachments and Hitches

Truss Boom

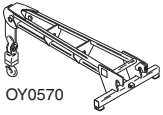

Use Appropriate Truss Boom Attachment Capacity Chart

To determine maximum capacity, refer to "Telehandler/Attachment/Fork Capacity" on page 5-5.

Suspend loads in accordance with requirements set forth in Section 1- General Safety Practices.

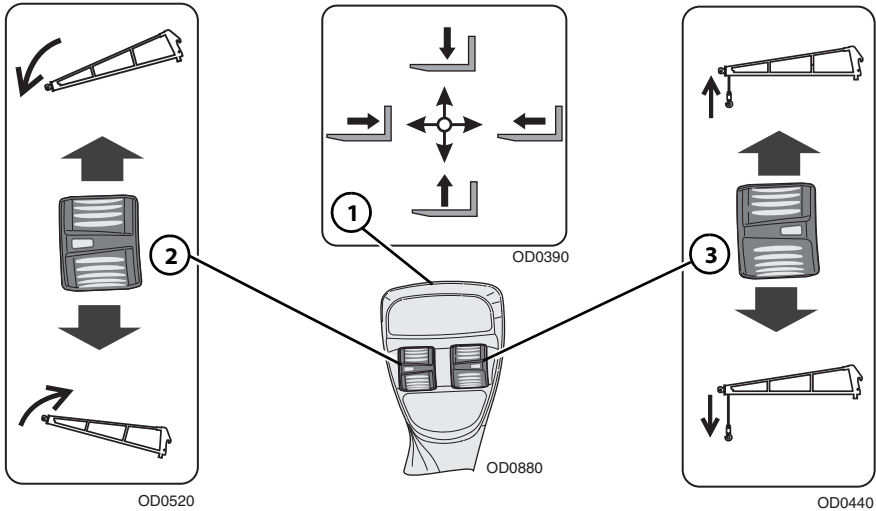

Joystick (1) controls movement of the boom.

Roller switch (2) controls truss boom tilt.

- Press roller switch down to tilt up.
- Press roller switch up to tilt down.

Winch Control (if equipped):

Roller switch (3) controls truss boom mounted winch.

- Press roller switch down to lower cable.
- Press roller switch up to raise cable.

Installation Procedures

- Refer to “Attachment Installation” on page 5-11.



WARNING

CRUSH HAZARD. Maintain a minimum of three wraps of wire rope on the cable drum at all times. Failure to comply could cause object or load to fall.

Operation:

- Weight of rigging must be included as part of total load being lifted.

Section 5- Attachments and Hitches

Coupler Mounted Hook

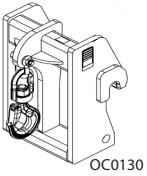

Use Appropriate Coupler Mounted Hook Capacity Chart

To determine maximum capacity, refer to "Telehandler/Attachment/
Fork Capacity" on page 5-5.

Suspend loads in accordance with requirements set forth in Section 1- General Safety Practices.

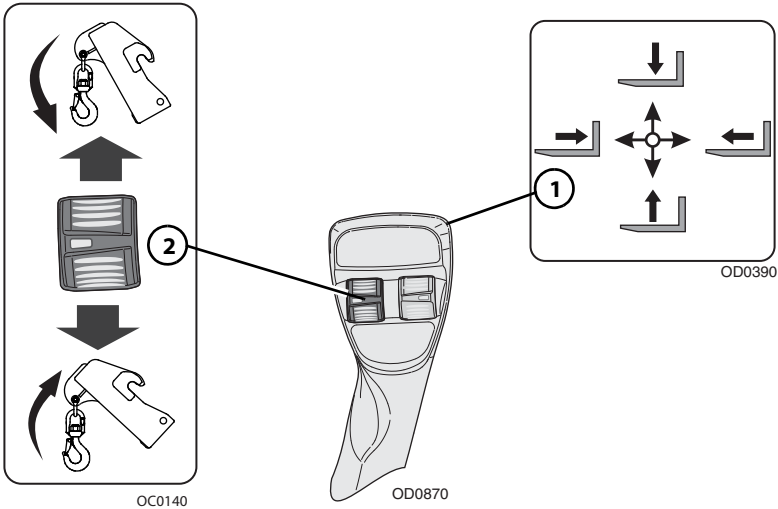

Joystick (1) controls movement of the boom.

Roller switch (2) controls coupler mounted hook tilt.

- Press roller switch down to tilt up.
- Press roller switch up to tilt down.

Installation Procedure:

- Refer to “Attachment Installation” on page 5-11.

Operation:

- Weight of rigging must be included as part of total load being lifted.

Section 5- Attachments and Hitches

Fork Mounted Hook

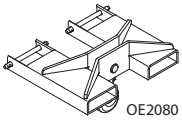

Use Appropriate Carriage Attachment Capacity Chart

To determine maximum capacity, refer to "Telehandler/Attachment/
Fork Capacity" on page 5-5.

Suspend loads in accordance with requirements set forth in Section 1- General Safety Practices.

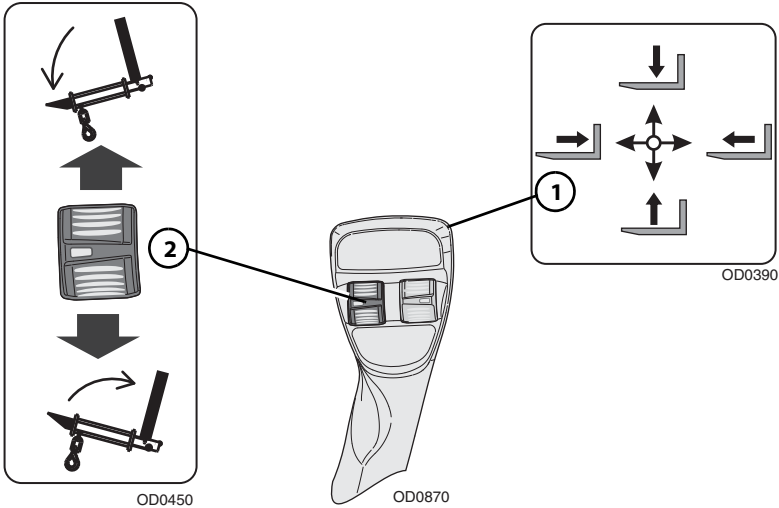

Joystick (1) controls movement of the boom.

Roller switch (2) controls carriage tilt.

- Press roller switch down to tilt up.
- Press roller switch up to tilt down.

Installation Procedure:

- Ensure carriage is properly installed. Refer to *"Attachment Installation"* on page 5-11.
- Secure the fork mounted hook to the forks by sliding the fork mounted hook onto the parent forks and install the retaining pin behind the vertical shank of the fork.

Operation:

- Pallet or lumber forks of an appropriate load rating must be used. Do not use with cubing or block forks.
- Fork mounted hook and rigging weight must be included as part of total load being lifted.
- Do not use with mast carriage attachment.
- Do not use fork mounted hook with attachments capable of rotating (i.e. side tilt and swing carriages) without disabling the rotation feature(s).

Section 5- Attachments and Hitches

Trash Hopper - Fork Mounted

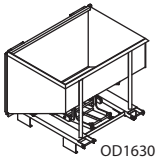

OD1630

Use Appropriate Trash Hopper Capacity Chart

To determine maximum capacity, refer to "Telehandler/Attachment/
Fork Capacity" on page 5-5.

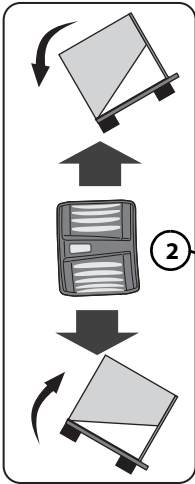

OD1640

2

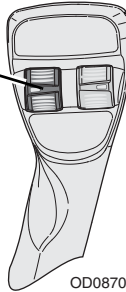

OD0870

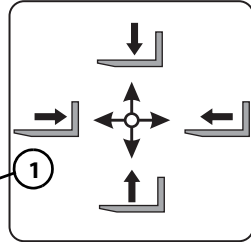

OD0390

1

Joystick (1) controls movement of the boom.

Roller switch (2) controls trash hopper tilt.

- Press roller switch down to tilt up.
- Press roller switch up to tilt down.

Installation Procedure:

- Ensure carriage is properly installed. Refer to “Attachment Installation” on page 5-11.
- Secure the fork mounted trash hopper to the forks by sliding the fork mounted trash hopper onto the parent forks and install the retaining pin behind the vertical shank of the fork.

Operation:

- Raise or lower boom to appropriate height for loading material.
- Travel in accordance with requirements set forth in Section 1- General Safety Practices.
- To release gate, tilt fork mounted trash hopper down approximately 10 degrees and engage bottom bumper on edge of dumpster. The gate will open allowing the contents to slide out.
- Tilt fork mounted trash hopper back to close and secure the gate.
- Do not use with mast carriage attachment.
- Do not use fork mounted trash hopper with attachments capable of rotating (i.e. side tilt carriages) without disabling the rotation feature(s).

Equipment Damage Precautions

- Except for lifting or dumping a load, the boom must be fully retracted for all fork mounted trash hopper operations.

Section 5- Attachments and Hitches

5.9 HITCHES AND TRAILER BRAKES

Machines may be equipped with various types of hitches. If not previously installed, secure hitch to machine with hardware supplied with installation.

Maximum towing capacity shall be the smallest of the telehandler and hitch capacities. Refer to page 9-18 for details.

Note: *Ensure hitch is in lowest position when towing trailer. Speed and/or load may need reduced if traveling on ground which is not level.*



WARNING

CRUSH HAZARD. Stay clear from area between machine and trailer.

Retrieval Hitch

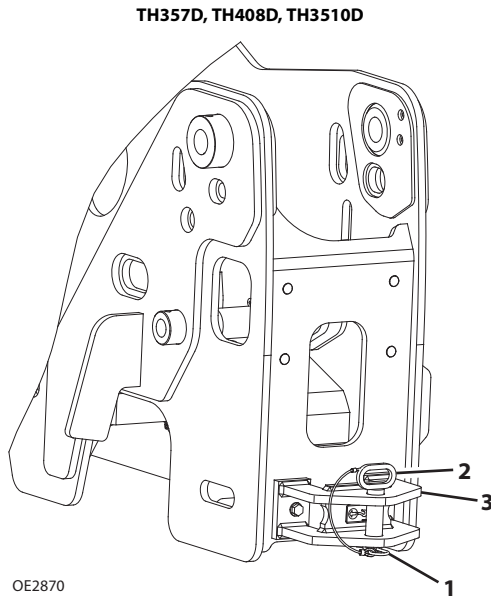
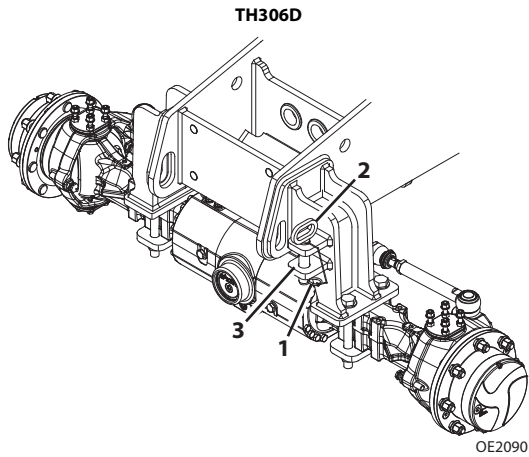

Connecting for retrieval:

1. Remove safety pin (1) and pull pin (2) from hitch (3).
2. Place pin through hitch and retrieval device. Secure pin with safety pin.

Note: Retrieval devices are not intended for trailer towing applications.

Section 5- Attachments and Hitches

Fixed Hitch

Hitch Capacities

Maximum combined weight of trailer and load 12 000 kg (26 450 lb)

Maximum vertical load at hitch interface 2500 kg (5500 lb)

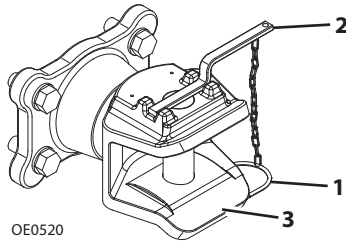

Connecting trailer for towing:

1. Remove safety pin (1) and pull pin (2) from hitch (3).
2. Align machine and tow eye of trailer.
3. Place pin through hitch and tow eye. Secure pin with safety pin.

Pin Hitch - CUNA C (Italy)

Hitch Capacities

Maximum combined weight of trailer and load 6000 kg (13 225 lb)

Maximum vertical load at hitch interface 1500 kg (3305 lb)

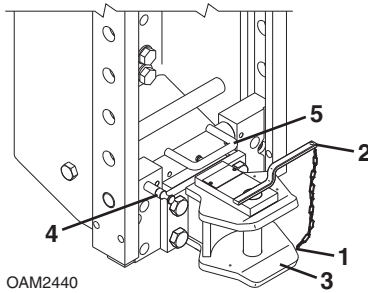

Connecting trailer for towing:

1. Remove safety pin (1) and pull pin (2) from hitch (3).
2. Align machine and tow eye of trailer.
3. Place pin through hitch and tow eye. Secure pin with safety pin.
4. If equipped, connect trailer harness to trailer plug.
5. If equipped, connect trailer hydraulics to rear auxiliary fittings.

Adjusting Hitch Height:

1. Pull lock pin (4) and lift handle (5) to release locking mechanism.
2. Move hitch to desired height.
3. Lower handle. When locking mechanism engages, lock pin will return to locked position.

Section 5- Attachments and Hitches

Pin Hitch - CUNA D2 (Italy)

Hitch Capacities

Maximum combined weight of trailer and load 12 000 kg (26 450 lb)

Maximum vertical load at hitch interface 2000 kg (4400 lb)

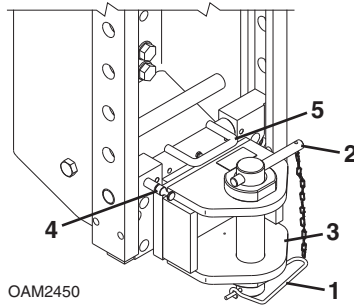

Connecting trailer for towing:

1. Remove safety pin (1) and pull pin (2) from hitch (3).
2. Align machine and tow eye of trailer.
3. Place pin through hitch and tow eye. Secure pin with safety pin.
4. If equipped, connect trailer harness to trailer plug.
5. If equipped, connect trailer hydraulics to rear auxiliary fittings.

Adjusting Hitch Height:

1. Pull lock pin (4) and lift handle (5) to release locking mechanism.
2. Move hitch to desired height.
3. Lower handle. When locking mechanism engages, lock pin will return to locked position.

EEC Manual Pin Hitch

Hitch Capacities

Maximum combined weight of trailer and load12 000 kg (26 450 lb)

Maximum vertical load at hitch interface.....2500 kg (5500 lb)

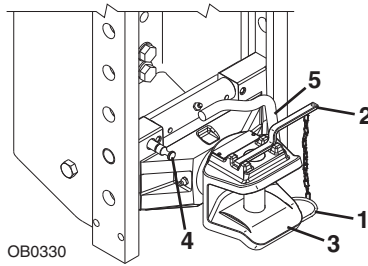

Connecting trailer for towing:

1. Remove safety pin (1) and pull pin (2) from hitch (3).
2. Align machine and tow eye of trailer.
3. Place pin through hitch and tow eye. Secure pin with safety pin.
4. If equipped, connect trailer harness to trailer plug.
5. If equipped, connect trailer hydraulics to rear auxiliary fittings.

Adjusting Hitch Height:

1. Pull lock pin (4) and lift handle (5) to release locking mechanism.
2. Move hitch to desired height.
3. Lower handle. When locking mechanism engages, lock pin will return to locked position.

Section 5- Attachments and Hitches

EEC Auto Hitch

Hitch Capacities

Maximum combined weight of trailer and load 12 000 kg (26 450 lb)

Maximum vertical load at hitch interface 2500 kg (5500 lb)

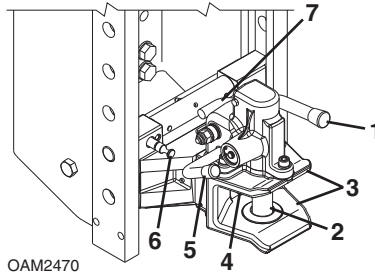

Connecting trailer for towing:

1. Rotate lever (1) until pin (2) fully retracts.
2. Align hitch mouth (3) and tow eye of trailer.
3. Reverse machine toward trailer.
4. After the tow eye contacts trigger (4), the pin and lever will be released.
5. If equipped, connect trailer harness to trailer plug.
6. If equipped, connect trailer hydraulics to rear auxiliary fittings.

Note: Use lever (5) to lower pin (2) after disconnecting from trailer.

Adjusting Hitch Height:

1. Pull lock pin (6) and lift handle (7) to release locking mechanism.
2. Move hitch to desired height.
3. Lower handle. When locking mechanism engages, lock pin will return to locked position.

Piton Frame and EEC Auto Hitch

Hitch Capacities

Maximum combined weight of trailer and load12 000 kg (26 450 lb)

Maximum vertical load at hitch interface2500 kg (5500 lb)

Note: See page 5-68 for Auto Hitch information.

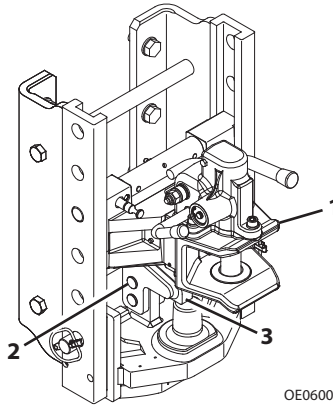

Connecting trailer for towing:

1. Raise Auto Hitch (1) to highest position.
2. Remove safety pin (2) and lift locking latch (3).
3. Insert safety pin to hold locking latch in the up position.
4. Align machine and tow eye of trailer.
5. Remove safety pin and lower locking latch. Secure locking latch with safety pin.
6. If equipped, connect trailer harness to trailer plug.
7. If equipped, connect trailer hydraulics to rear auxiliary fittings.

Section 5- Attachments and Hitches

Hydraulic Hitch

Hitch Capacities

Maximum combined weight of trailer and load 12 000 kg (26 450 lb)

Maximum vertical load at hitch interface 2500 kg (5500 lb)

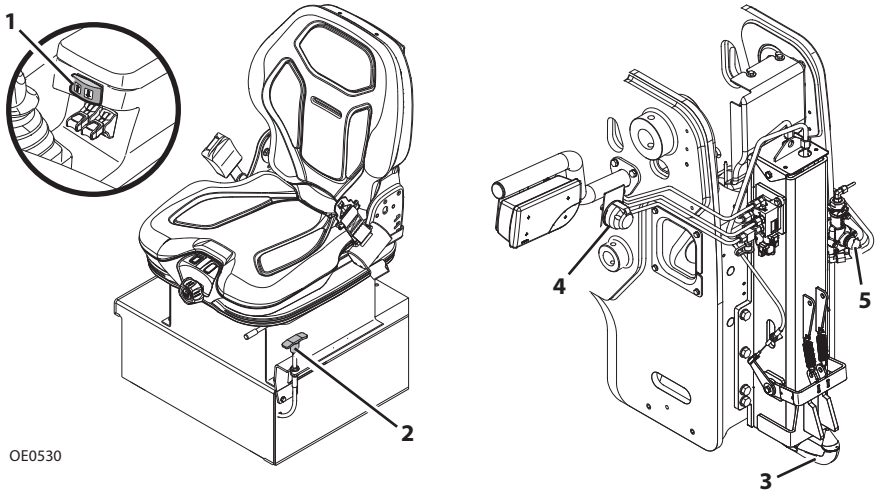

OE0530

Connecting trailer for towing:

1. Depress and hold right side of hydraulic hitch switch (1) to raise hitch safety posts off safety hooks.
2. Pull and hold cable release (2) to withdraw safety hooks. Cable can be released once posts are lower than safety hooks.
3. Depress and hold left side of hydraulic hitch switch to lower the hitch (3) to the required height.
4. Reverse machine until the hitch is under the center of the tow eye.
5. Depress and hold right side of hydraulic hitch switch to raise hitch until the safety hooks are engaged.
6. If equipped, connect trailer harness to trailer plug (4).
7. If equipped, connect trailer brake line to trailer coupling (5). See page 5-72.

Rear Auxiliary Hydraulics

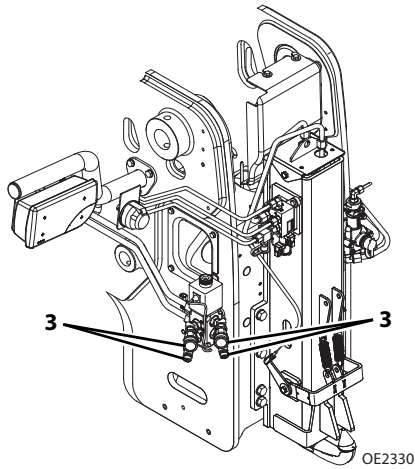
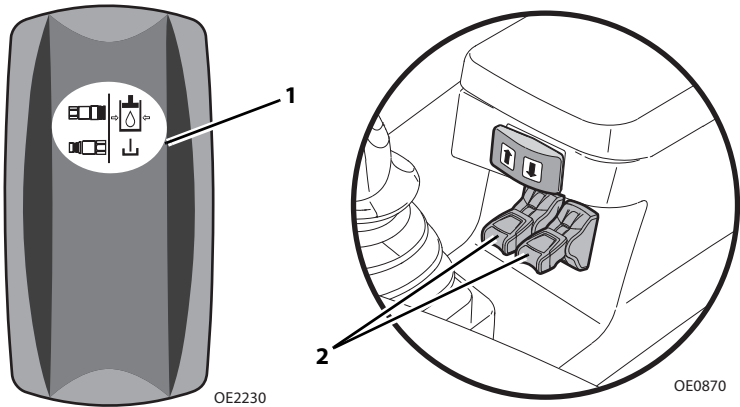

1. Press and hold auxiliary decompression switch (1) on right control panel then operate the rear auxiliary hydraulic levers (2) to relieve pressure at rear auxiliary fittings (3).
2. Perform "Shut-Down Procedure" on page 4-6.
3. Connect hoses to auxiliary fittings.

Section 5- Attachments and Hitches

Trailer Brakes

CE & AUS

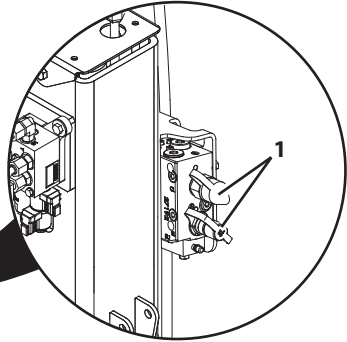

ITALY

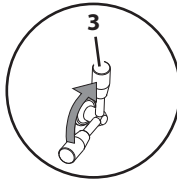
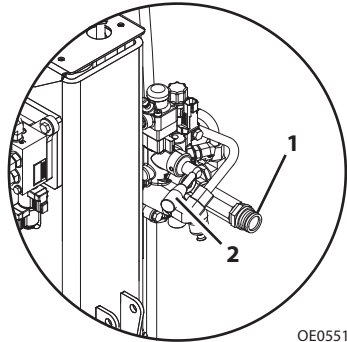

OE0551

Connecting trailer brake system:

CE & AUS

1. Ensure trailer is properly connected for towing.
2. Connect trailer brake lines to machine couplings (1).

Italy

1. Ensure trailer is properly connected for towing.
2. Lever should be in horizontal position (2).
3. Connect trailer brake line to machine coupling (1).
4. Lift lever to vertical position (3).

SECTION 6 - EMERGENCY PROCEDURES

6.1 TOWING A DISABLED PRODUCT

The following information assumes telehandler cannot be moved under its own power.

- Before moving the telehandler, read all of the following information to understand options available. Then select the appropriate method.
- Machine mounted retrieval devices provide suitable means to attach a tow rope, chain or tow bar only in the event the telehandler becomes stuck or disabled.
- Retrieval devices are not intended for on-road trailer towing applications.
- The steering system permits manual steering if engine or power assist feature fails; however, **steering will be slow and will require much greater force.**
- **DO NOT** attempt to tow a telehandler that is loaded or the boom/attachment is raised above 1,2 m (4 ft).

Moving Short Distances

- If it is only necessary to move telehandler a short distance, less than 30 m (100 ft), it is permissible to use a vehicle of sufficient capacity to tow the unit with no previous preparation.

Moving Longer Distance

- See Service Manual for information.
- Dependant on local regulations the appropriate machine Service Manual should be kept in the cab of homologated machines at all times.

Contact the local Caterpillar dealer for specific instructions if neither of these methods are applicable.

Section 6- Emergency Procedures

6.2 EMERGENCY LOWERING OF BOOM

In the event of total loss of engine power or hydraulic pump failure with an elevated load, the situation must be properly evaluated and dealt with on an individual basis. **Contact the local Caterpillar dealer for specific instructions.**

Secure the telehandler using the following procedures:

1. Clear the area around telehandler of all personnel.
2. Apply the parking brake. Place the transmission in "NEUTRAL".
3. Block all four wheels.
4. Section off a large area under the boom to restrict any personnel from entering this area.
5. See Service Manual for information.

6.3 EMERGENCY EXIT FROM ENCLOSED CAB

In an emergency, the rear window or right side window can be used to exit the telehandler if it is not possible to use the cab door.

If possible, fully lower the boom, shut off the engine and remove ignition key before using any of the following procedures to exit the telehandler.

Rear Window Inside Cab

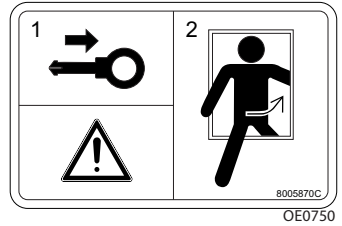
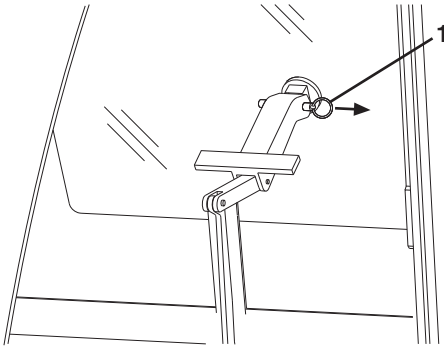

1. Remove the latch pin (1).
2. Swing open the window and exit the telehandler.

Section 6- Emergency Procedures

Rear Window Outside Cab (if equipped)

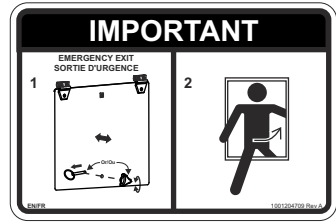
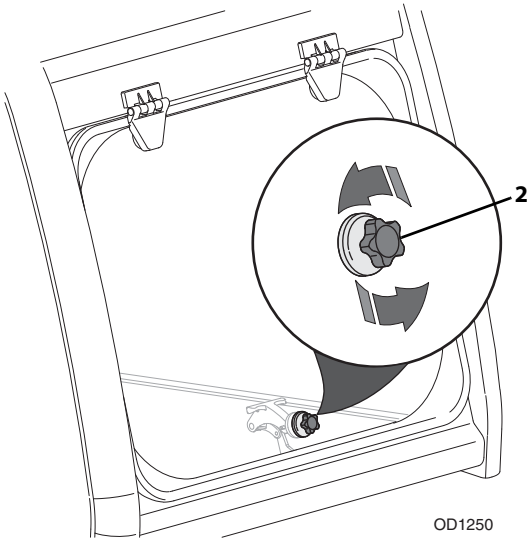

1. Remove the knob (2) securing the window.
2. Swing open the window and exit the telehandler.

Right Side Window (Agriculture)

Note: Only exit through the right side window if it is not possible to exit through the cab door or rear window.

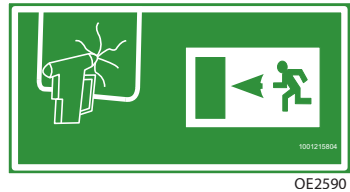
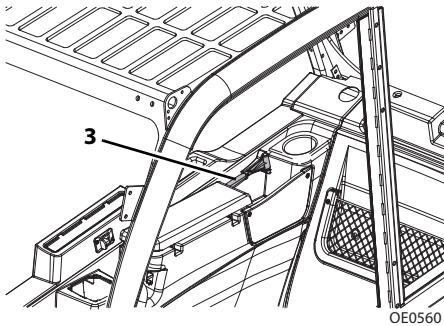

1. Remove the escape hammer (3) located below the right hand side window.
2. Use the hammer to break the window and exit the telehandler.

SECTION 7 - LUBRICATION AND MAINTENANCE

7.1 INTRODUCTION

This section is intended as information to assist the operator to perform maintenance tasks only. Service product in accordance with maintenance schedule on the following pages.

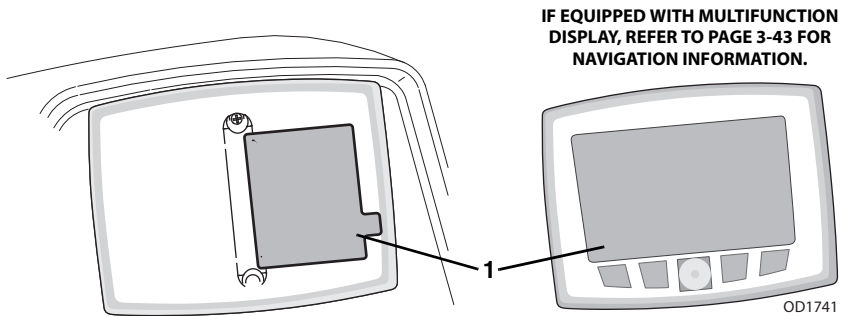

Lubrication and maintenance charts (1) contain instructions that must be followed to keep this product in good operating condition. Operation & Maintenance Manual and Service Manual contain more detailed service information with specific instructions. If equipped with Multifunction Display, refer to page 3-43 for navigation information.

Clothing and Safety Gear

- Wear all protective clothing and personal safety devices issued to you or called for by job conditions
- **DO NOT** wear loose clothing or jewelry that can get caught on controls or moving parts

Section 7- Lubrication and Maintenance

7.2 GENERAL MAINTENANCE INSTRUCTIONS

Prior to performing any service or maintenance on the telehandler, follow the shut-down procedure on page 4-6 unless otherwise instructed. Ensure telehandler is level, for proper fluid readings.

- Clean lubrication fittings before lubricating.
- After greasing telehandler, cycle all functions several times to distribute lubricants. Perform this maintenance procedure without attachment installed.
- Apply a light coating of engine oil to all linkage pivot points.
- Intervals shown are for normal usage and conditions. Adjust intervals for abnormal usage and conditions.
- Check all lubricant levels when lubricant is cool, with the exception of the transmission fluid. For ease of filling hydraulic reservoir, use a funnel with a hose or flexible tube for best results.











WARNING

CUT/CRUSH/BURN HAZARD. Do not perform service or maintenance on the machine with engine running with the exception of transmission fluid level check.

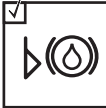
7.3 SERVICE AND MAINTENANCE SCHEDULES

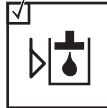
10 & 1st 50 Hour Maintenance Schedule - TH306D

EVERY
10 

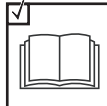
 Check Fuel Level	 Check Tire Condition & Pressure	 Check Brake Fluid Level	 Check Engine Oil Level	 Check Hydraulic Oil Level
 Drain Fuel/Water Separator	 Check Air Filter	 Check DEF Level (SN TD200150 to Present SN TA200150 to Present)	 Check Engine Coolant Level	 Additional Checks - Section 8

1st
50 

 Check Wheel Lug Nut Torque
--

OE2380

Section 7- Lubrication and Maintenance

50, 1st 250 & 250 Hour Maintenance Schedule - TH306D

EVERY

50 



Lubrication
Schedule



Check
Washer
Fluid



Check Cab
Air Filter

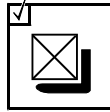

Check
LSI System

1st

250 

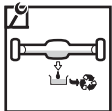

Change
Axle Oil

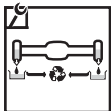

Change Wheel
End Oil

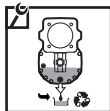

Change Front
Axle Drop
Box Oil

EVERY

250 



Lubrication
Schedule

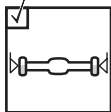

Check Wheel
End Oil Levels



Check Boom
Wear Pads

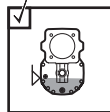

Check Front
Axle Drop
Box Oil Level

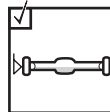

Check Axle
Oil Level

OE2390

Section 7 - Lubrication and Maintenance

500, 750 & 1000 Hour Maintenance Schedule - TH306D

EVERY

500 

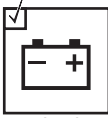

Check
Battery

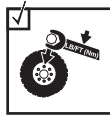

Check Wheel
Lug Nut Torque

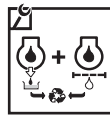

Change Engine
Oil and Filter



Check
Fan Belt



Change
Air Filter
Elements

EVERY

750 



Change
Hydraulic
Tank Breather



Change
Hydraulic Filters

EVERY

1000 

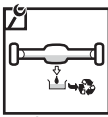

Change
Axle Oil

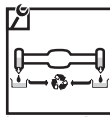

Change Wheel
End Oil



Check Air
Intake System

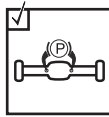

Check Park
Brake

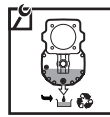

Change Front
Axle Drop
Box Oil

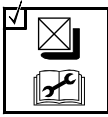

Check LSI
Calibration



Change
Fuel Filters

OE2400

Section 7- Lubrication and Maintenance

1500, 2000 & 3000 Hour Maintenance Schedule - TH306D

EVERY
1500 



Change
Hydraulic Fluid
and Filters



Change DEF
Pump Filter
(SN TD200150 to Present
SN TA200150 to Present)

EVERY
2000 



Change
Engine Coolant



Change DEF
Tank Filter
(SN TD200150 to Present
SN TA200150 to Present)

EVERY
3000 













Change
Fan Belt

OE2410

Section 7- Lubrication and Maintenance

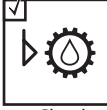
10 & 1st 50 Hour Maintenance Schedule - TH357D, TH408D, TH3510D

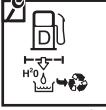
EVERY
10 

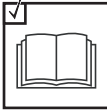
 Check Fuel Level	 Check Tire Condition & Pressure	 Check Brake Fluid Level	 Check Engine Oil Level	 Check Hydraulic Oil Level
 Check Transmission Oil Level	 Check Air Filter	 Check DEF Level <small>(SN TD600150 to Present SN TH900150 to Present SN TH200150 to Present SN T7F00150 to Present)</small>	 Drain Fuel/Water Separator	 Check Engine Coolant Level
 Additional Checks - Section 8				

1st
50 

 Check Wheel Lug Nut Torque

OE2242

Section 7- Lubrication and Maintenance

50, 1st 250 & 250 Hour Maintenance Schedule - TH357D, TH408D, TH3510D

EVERY

50 



Lubrication
Schedule



Check
Washer
Fluid



Check Cab
Air Filter



Check
LSI System

1st

250 

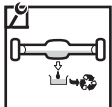

Change
Axle Oil

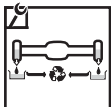

Change Wheel
End Oil

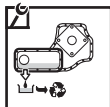

Change
Transfer
Case Fluid

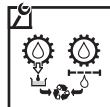

Change
Transmission
Fluid and Filter

EVERY

250 



Lubrication
Schedule

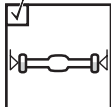

Check Wheel
End Oil Levels

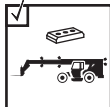

Check Boom
Wear Pads

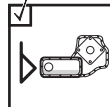

Check
Transfer Case
Fluid Level

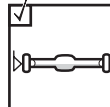

Check Axle
Oil Level

OE2251

Section 7- Lubrication and Maintenance

500, 750 & 1000 Hour Maintenance Schedule - TH357D, TH408D, TH3510D

EVERY

500 



Change Fuel Filters

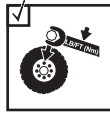

Check Wheel Lug Nut Torque

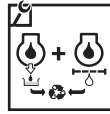

Change Engine Oil and Filter

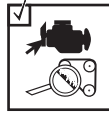

Check Fan Belt



Change Air Filter Elements

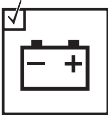

Check Battery

EVERY

750 



Change Hydraulic Tank Breather



Change Hydraulic Filters

EVERY

1000 

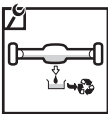

Change Axle Oil

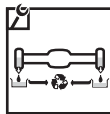

Change Wheel End Oil



Check Air Intake System

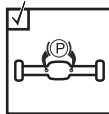

Check Park Brake

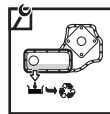

Change Transfer Case Fluids



Change Transmission Fluid and Filter

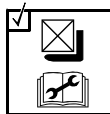

Check LSI Calibration

OE2261

Section 7- Lubrication and Maintenance

1500, 2000 & 3000 Hour Maintenance Schedule - TH357D, TH408D, TH3510D

EVERY
1500 



Change Hydraulic Fluid and Filters



Change DEF Pump Filter

(SN TD600150 to Present
SN TH900150 to Present
SN TH200150 to Present
SN T7F00150 to Present)



Change Crankcase Vent Filter

EVERY
2000 



Change Engine Coolant



Change DEF Tank Filter

(SN TD600150 to Present
SN TH900150 to Present
SN TH200150 to Present
SN T7F00150 to Present)

EVERY
3000 



Change Fan Belt

OE2352

6000 & 12000 Hour Maintenance Schedule - TH357D, TH408D,
TH3510D

EVERY
6000 
or
3 Years



Add Engine
Coolant
Extender

EVERY
12000 
or
6 Years



Change
Engine Coolant

OE1011

Note: If hour and year intervals are listed, use the interval that occurs first. Refer to Engine Operation & Maintenance Manual for additional information.

Section 7- Lubrication and Maintenance

7.4 LUBRICATION SCHEDULES

TH306D

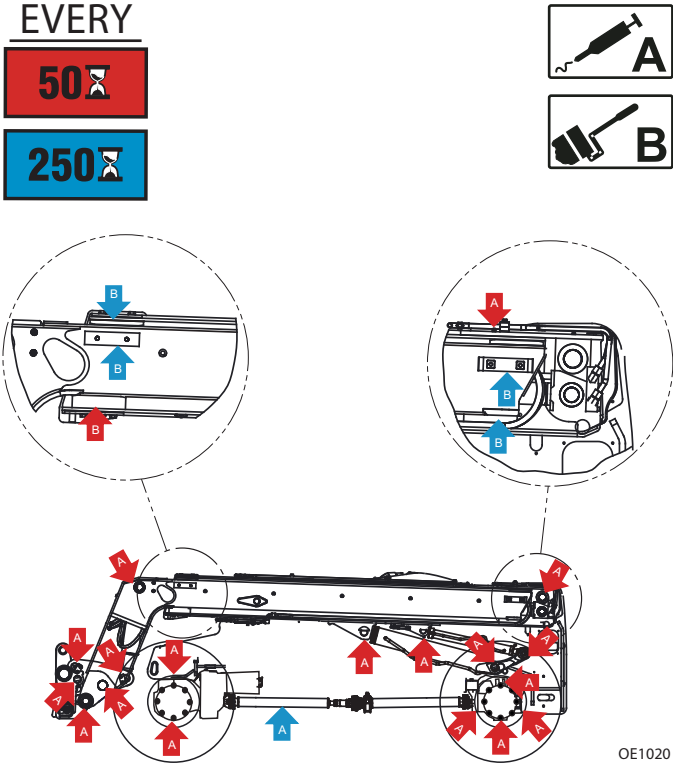

TH357D, TH408D, TH3510D

EVERY

50 

250 

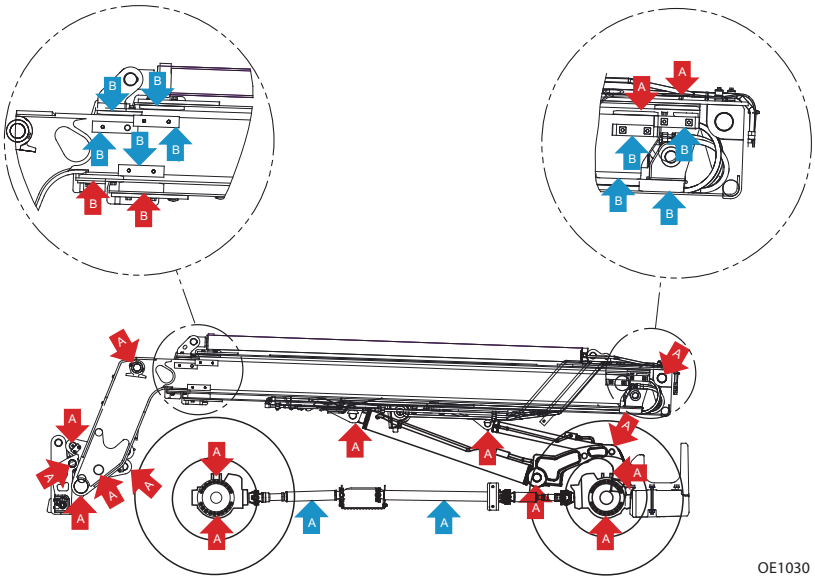

OE1030

This Page Intentionally Left Blank

7.5 OPERATOR MAINTENANCE INSTRUCTIONS

Engine Maintenance Components

TH306D

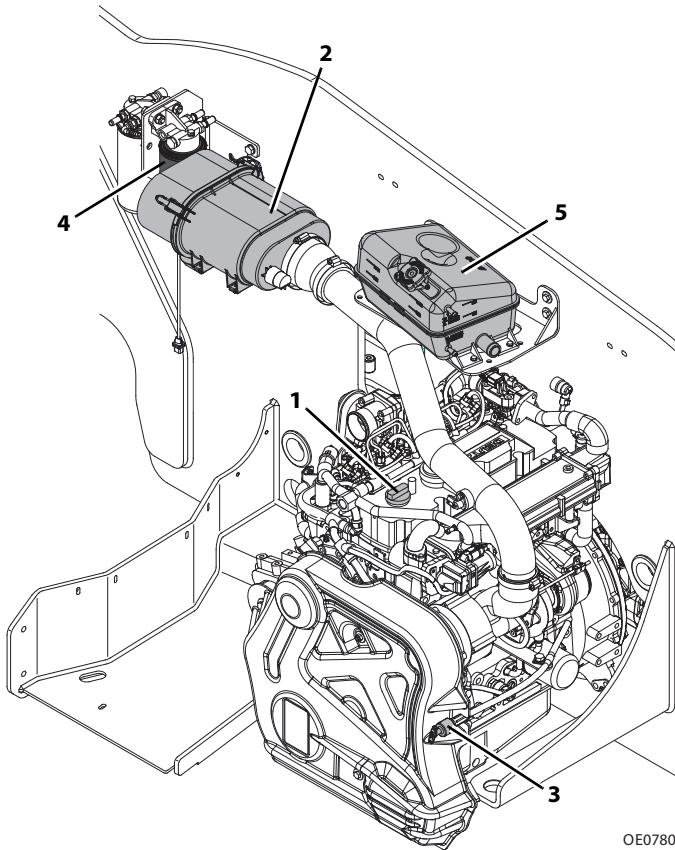

1. **Engine Oil Cap:** See page 7-23.
2. **Air Cleaner:** See page 7-24.
3. **Engine Oil Dipstick:** See page 7-23.
4. **Primary Fuel Filter:** See page 7-21.
5. **Surge Tank:** See page 7-33.

Section 7- Lubrication and Maintenance

TH357D - SN TD600150 to Present, TH408D - SN TH900150 to Present,
TH3510D - SN TH200150 to Present, SN T7F00150 to Present (3.4 Liter Engine)

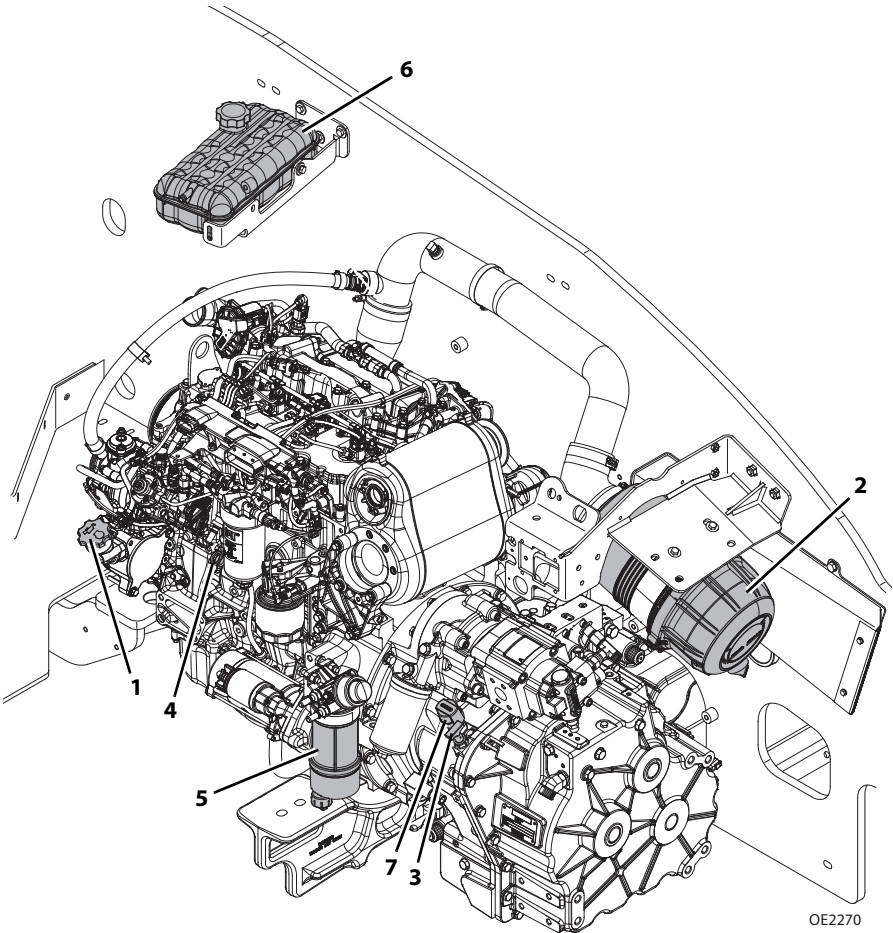

1. **Engine Oil Cap:** See page 7-23.
2. **Air Cleaner:** See page 7-24.
3. **Transmission Fluid Dipstick:** See page 7-30.
4. **Engine Oil Dipstick:** See page 7-23.
5. **Primary Fuel Filter:** See page 7-21.
6. **Surge Tank:** See page 7-33.
7. **Transmission Fluid Plug:** See page 7-30.

Section 7- Lubrication and Maintenance

TH357D - SN TD600150 to Present, TH408D - SN TH900150 to Present,
TH3510D - SN TH200150 to Present, SN T7F00150 to Present (4.4 Liter Engine)

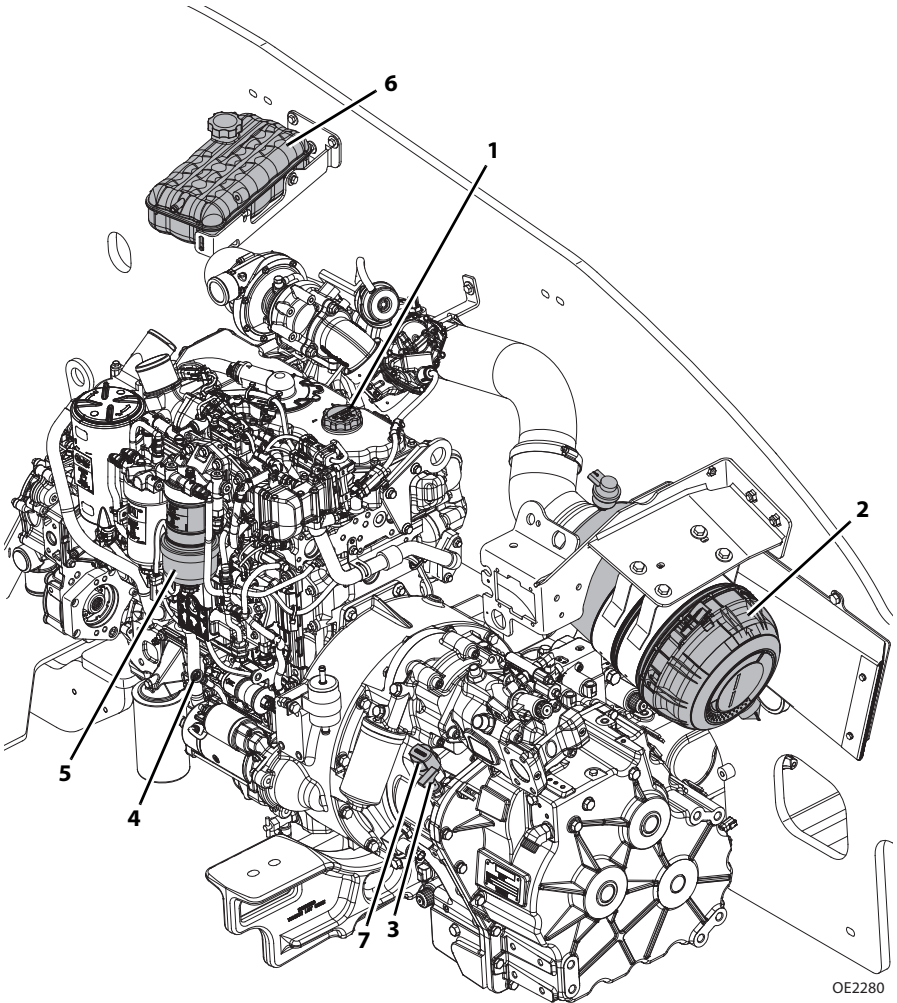

OE2280

1. **Engine Oil Cap:** See page 7-23.
2. **Air Cleaner:** See page 7-24.
3. **Transmission Fluid Dipstick:** See page 7-30.
4. **Engine Oil Dipstick:** See page 7-23.
5. **Primary Fuel Filter:** See page 7-21.
6. **Surge Tank:** See page 7-33.
7. **Transmission Fluid Plug:** See page 7-30.

Section 7- Lubrication and Maintenance

TH357D - SN TD700150 to Present, TH408D - SN TH400150 to Present
TH3510D - SN TH300150 to Present, SN THZ00150 to Present

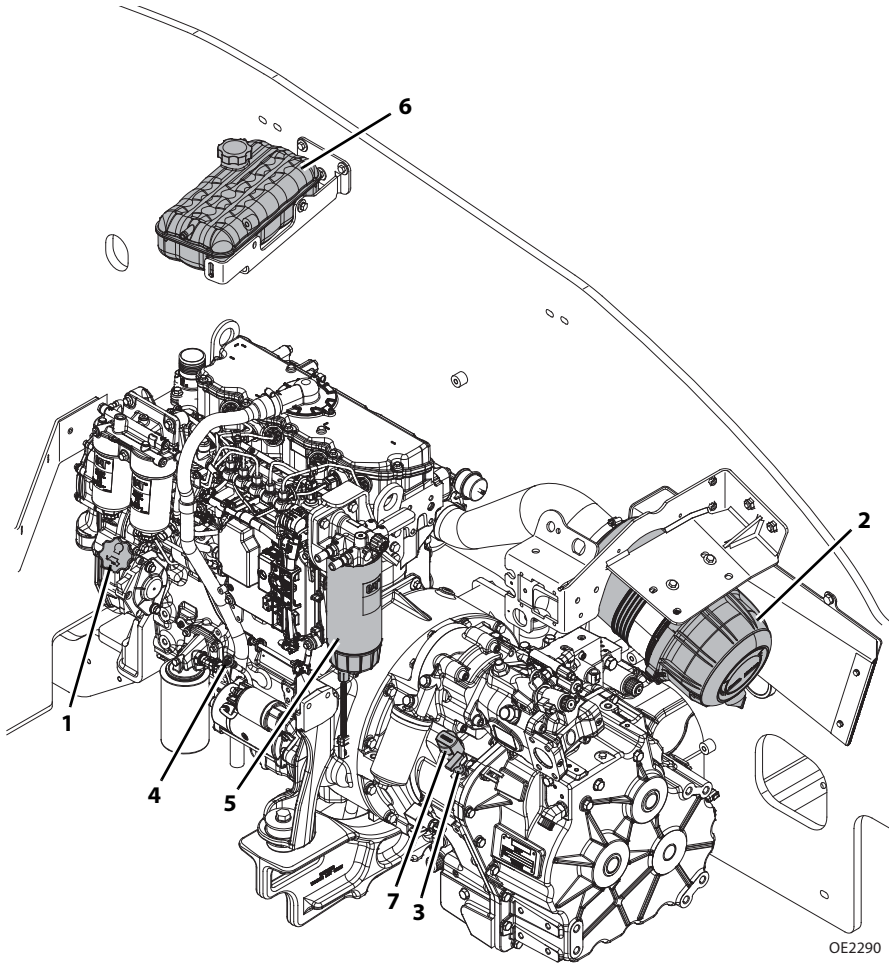

1. **Engine Oil Cap:** See page 7-23.
2. **Air Cleaner:** See page 7-24.
3. **Transmission Fluid Dipstick:** See page 7-29.
4. **Engine Oil Dipstick:** See page 7-23.
5. **Primary Fuel Filter:** See page 7-19.
6. **Surge Tank:** See page 7-33.
7. **Transmission Fluid Plug:** See page 7-29.

This Page Intentionally Left Blank

Section 7- Lubrication and Maintenance

Fuel System

A. Fuel Level Check

10 
OW0970

OW0990

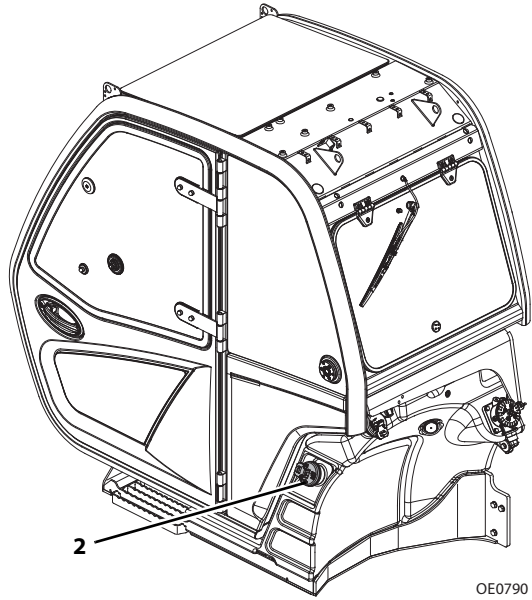
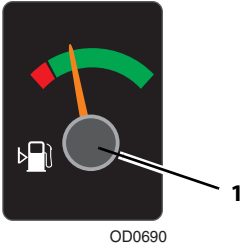

1. Check Fuel Gauge (1) located in right side of Instrument Panel in cab.
2. If fuel is low, proceed to fuel source and perform "Shut-Down Procedure" on page 4-6.
3. Turn fuel tank cap (2) to remove from filler neck.
4. Add fuel as needed.
5. Replace fuel tank cap.

Note: Replenish diesel fuel at end of each work shift to minimize condensation.

NOTICE

EQUIPMENT DAMAGE. Do not allow machine to run out of fuel during operation. See Engine Operation & Maintenance Manual for details prior to servicing.

B. Drain Fuel/Water Separator

10 
OW0970



TH306D

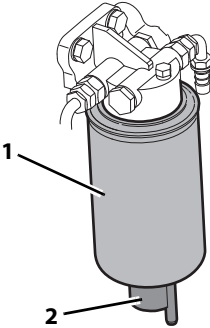

TH357D
SN TD600150 TO PRESENT
TH408D
SN TH900150 TO PRESENT
TH3510D
SN TH200150 TO PRESENT
SN T7F00150 TO PRESENT
(3.4 Liter Engine)

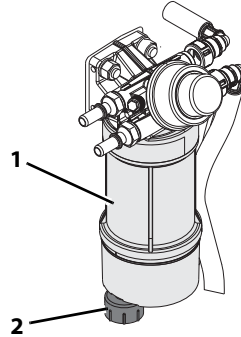

TH357D
SN TD600150 TO PRESENT
TH408D
SN TH900150 TO PRESENT
TH3510D
SN TH200150 TO PRESENT
SN T7F00150 TO PRESENT
(4.4 Liter Engine)

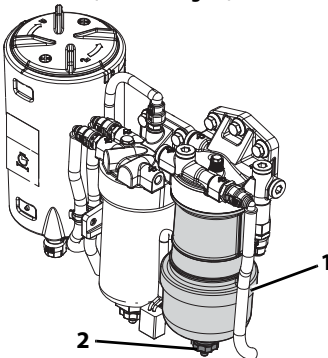

TH357D
SN TD700150 TO PRESENT
TH408D
SN TH400150 TO PRESENT
TH3510D
SN TH300150 TO PRESENT
SN THZ00150 TO PRESENT

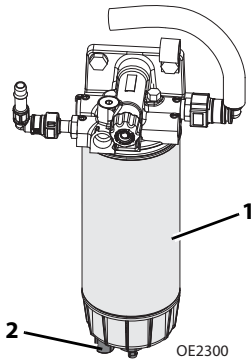

1. Perform "Shut-Down Procedure" on page 4-6.
2. Open engine cover.
3. Loosen drain cock (2) on underside of fuel filter (1) and allow all water to drain into a glass until clear fuel is visible. Tighten drain cock.
4. Close and secure engine cover.

Section 7- Lubrication and Maintenance

Emission System (SN TD200150 to Present, SN TA200150 to Present, SN TD600150 to Present, SN TH900150 to Present, SN TH200150 to Present, SN T7F00150 to Present)

A. Diesel Emission Fluid (DEF) Level Check

10 
OW0970



1

TH306D

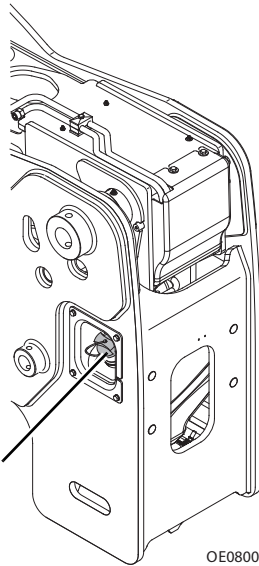

2

TH357D, TH408D, TH3510D

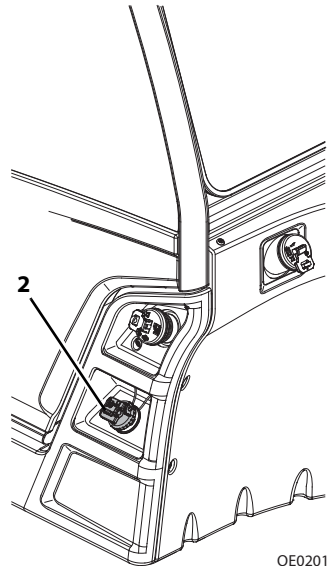

2

1. Check Diesel Emission Fluid (DEF) Gauge (1) located in right side of Instrument Panel in cab.
2. If DEF is low, proceed to DEF source and perform "Shut-Down Procedure" on page 4-6.
3. Turn DEF tank cap (2) to remove.
4. Add DEF as needed.
5. Replace DEF tank cap.

NOTICE

EQUIPMENT DAMAGE. Do not allow machine to run out of Diesel Emission Fluid (DEF) during operation. See the Engine Operation & Maintenance Manual for details prior to servicing.

Engine Oil

A. Engine Oil Level Check

10 
OW0970

OW1020

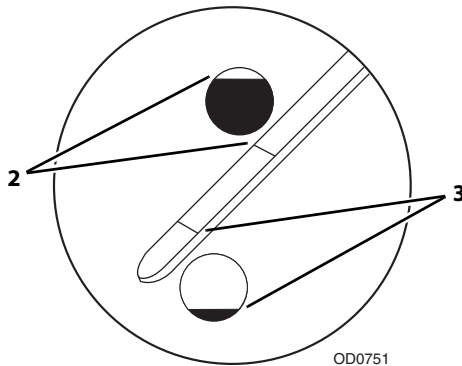

1. Perform "Shut-Down Procedure" on page 4-6.
2. Open engine cover.
3. Remove dipstick and check oil mark. Oil should be between full (2) and add (3) marks of dipstick.
4. Replace dipstick.
5. If oil is low, remove oil fill cap and add oil to bring oil up to full mark.
6. Replace oil fill cap.
7. Close and secure engine cover.

Section 7- Lubrication and Maintenance

Air Intake System

A. Air Cleaner Check

10 
OW0970

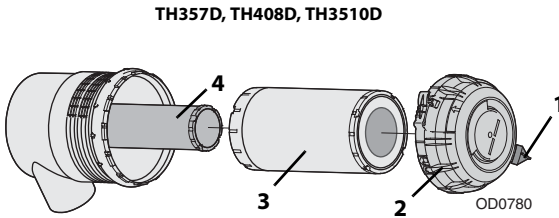
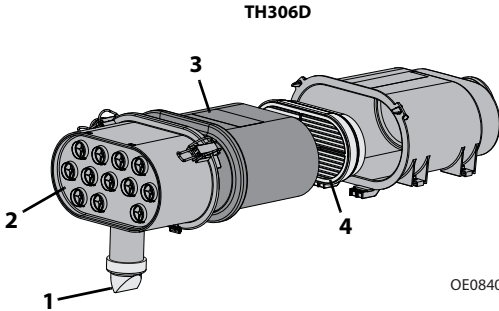

1. Perform "Shut-Down Procedure" on page 4-6.
2. Open engine cover.
3. Remove dust from vacuumator valve (1) by squeezing bottom of valve to allow loose particles to fall out.
4. Close and secure engine cover.

NOTICE

EQUIPMENT DAMAGE. Only remove air cleaner cover to service elements. Excessive access to check elements can lead to premature element and/or engine failure.

B. Filter Change

Note: Change elements as air cleaner restriction indicator indicates or every two years. Use the interval that occurs first.

1. Perform "Shut-Down Procedure" on page 4-6.
2. Open engine cover.
3. Unlock air cleaner cover (2) and remove from air cleaner.
4. Remove outer primary element (3). Inspect element for damage then discard.
5. Thoroughly clean interior of air cleaner canister and vacuator valve.
6. Replace inner safety element (4) every third primary element change or if primary element was found to be damaged. If replacing inner safety element at this time, carefully slide element out and replace with new element.
7. Slide new primary element over inner safety element making sure sealing edge is flush with base of air cleaner.
8. Position air cleaner cover in place and lock into position.
9. Close and secure engine cover.

Note: Elements should never be washed or reused. Always install new elements.

NOTICE

EQUIPMENT DAMAGE. Primary and safety elements are required to be replaced if used in an application longer than two years regardless of hours of operation.

Section 7- Lubrication and Maintenance

Tires

A. Tire Air Pressure Check



1. Perform “Shut-Down Procedure” on page 4-6.
2. Remove valve stem cap.
3. Check tire pressure.
4. Add air if required. See page 9-11 for tire pressures.
5. Replace valve stem cap.

B. Tire Damage

For pneumatic tires, when any cut, rip or tear is discovered that exposes sidewall or tread area cords in the tire, measures be taken to remove the product from service immediately. Arrangements must be made for replacement of the tire or tire assembly.

For polyurethane foam filled tires, when any of the following are discovered, measures must be taken to remove the product from service immediately. Arrangements must be made for replacement of the tire or tire assembly.

- Smooth even cut through the cord plies which exceeds 7,5 cm (3 in) in total length
- Any tears or rips (ragged edges) in cord plies which exceeds 2,5 cm (1 in) in any direction
- Any punctures which exceed 1 in 2,5 cm (1 in) in diameter

If a tire is damaged but within above noted criteria, tire must be inspected daily to ensure damage has not propagated beyond allowable criteria.

C. Tire and Wheel Replacement

Machines equipped with pneumatic tires from manufacturer must use pneumatic replacements. Machines equipped with foam filled or ballast filled tires from manufacturer must use foam filled or ballast filled replacements.

It is recommended that a replacement tire to be same size, ply and brand as originally installed. Refer to appropriate parts manual for ordering information. If not using an approved replacement tire, replacement tires must have the following characteristics:

- Equal or greater ply/load rating and size of original
- Tire tread contact width equal or greater than original
- Wheel diameter, width and offset dimensions equal to the original
- Approved for application by tire manufacturer (including inflation pressure and maximum tire load)

Section 7- Lubrication and Maintenance

Due to size variations between tire brands, when selecting and installing a replacement tire ensure both tires on the axle are the same.

The rims installed have been designed for stability requirements which consist of track width, tire pressure and load capacity. Size changes such as rim width, center piece location, larger or smaller diameter, etc., without written factory recommendations, may result in unsafe condition regarding stability.

When replacing tires and wheels see "Jacking Up Machine" on page 7-40.

D. Wheel Installation

Torque lug nuts after first 50 hours and after each wheel installation.

Note: If machine is equipped with directional tire assemblies, wheel and tire assemblies must be installed with directional tread pattern "arrows" facing in direction of forward travel.

1. Start all nuts by hand to prevent cross threading. DO NOT use a lubricant on threads or nuts.

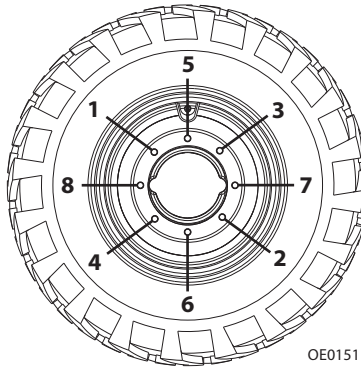

2. Tighten lug nuts in an alternating pattern as indicated in figure. See page 9-11 for torque value.



WARNING

TIP OVER HAZARD. Lug nuts must be installed and maintained at the proper torque to prevent loose wheels, broken studs and possible separation of wheel from the axle.

Section 7- Lubrication and Maintenance

Hydraulic Oil

A. Hydraulic Oil Level Check

10 
OW0970

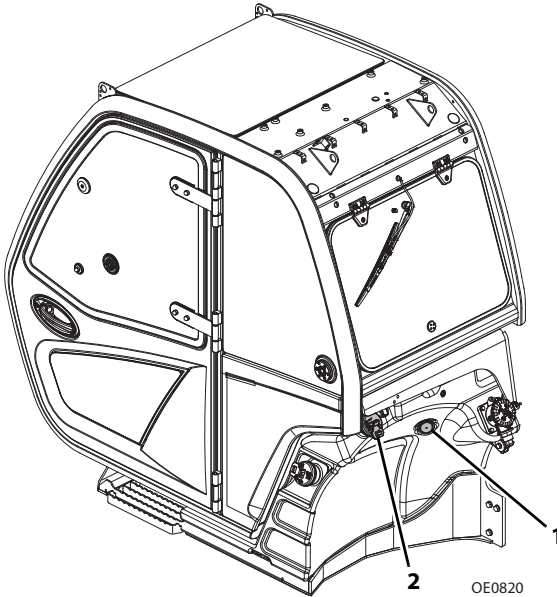

1. Be sure all cylinders are fully retracted, outriggers (if equipped) are fully raised and machine is level.
2. Perform "Shut-Down Procedure" on page 4-6.
3. Allow hydraulic oil to cool. Check fluid level at sight gauge (1). Oil level should be visible in gauge window.
4. Remove fill cap (2). Add fluid to bring oil up to the center of the sight gauge.
5. Replace hydraulic oil fill cap.

This Page Intentionally Left Blank

Section 7- Lubrication and Maintenance

Transmission Oil (TH357D, TH408D, TH3510D)

A. Transmission Oil Level Check

10 
OW0970

OW1050

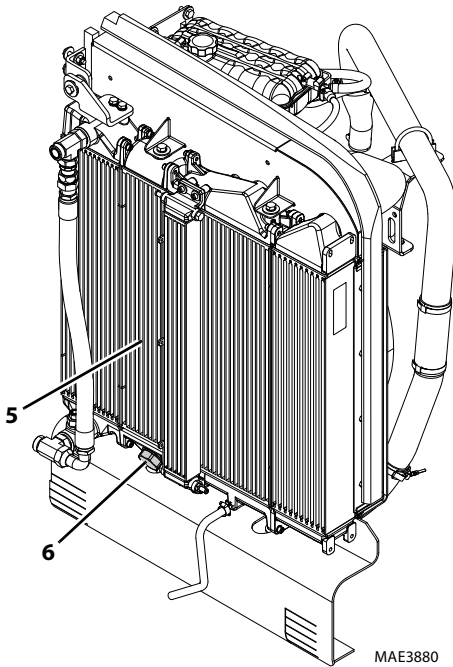
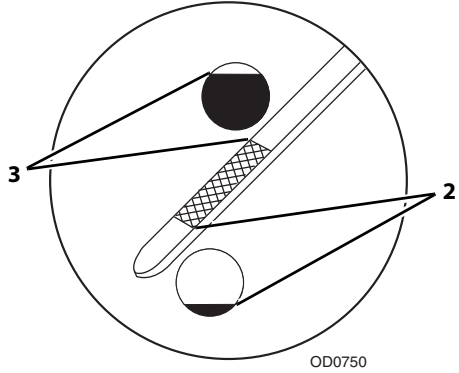
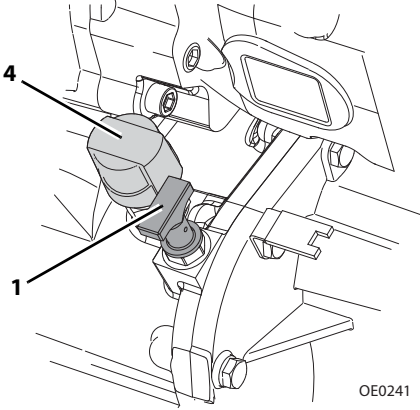

Note: Final transmission oil level must always be checked with engine at idle and transmission oil at operating temperature (minimum 80°C/176°F).

Section 7- Lubrication and Maintenance

1. Start machine on a firm, level surface, level machine, fully retract boom, lower boom, place transmission in (N) NEUTRAL, engage park brake and run engine at idle.
2. Open engine cover.
3. Remove the transmission dipstick (1) and check the oil level. The cold oil level after 2-3 minutes of idle must be between the MIN (2) and MAX (3) oil level marks.
4. If the oil is low, remove plug (4) and add oil as required.
5. Replace the transmission dipstick and plug.
6. Close and secure the engine cover.
7. Ensure that the front of the machine is clear of persons or obstacles.
8. Apply the service brake and disengage the park brake. Place the transmission in (F) FORWARD at 4th gear.
9. Stall the transmission against service brake at full throttle a maximum of 60 seconds. If transmission temperature warning light illuminates, go to step 12.
10. Allow the engine to run at idle for 30 seconds.
11. Repeat steps 9 and 10 three more times or until the transmission temperature warning light illuminates.
12. Place the transmission in (N) NEUTRAL and apply the park brake. Allow the engine to run at idle for 30 seconds.
13. Open the engine cover.
14. Verify that top of transmission oil cooler (5) is warm to determine that the bypass valve (6) has closed and oil is circulating through the cooler. If the top tank of the transmission oil cooler is not warm, repeat steps 6 thru 10.
15. Remove the transmission dipstick (1) and check the oil level. The oil level should be between the MIN and MAX level marks.
16. Add oil as required.
17. Replace the transmission dipstick and plug.
18. Close and secure the engine cover.
19. Shut engine OFF.

Section 7- Lubrication and Maintenance

Brake Fluid

A. Brake Fluid Level Check

10 
OW0970

OD1380

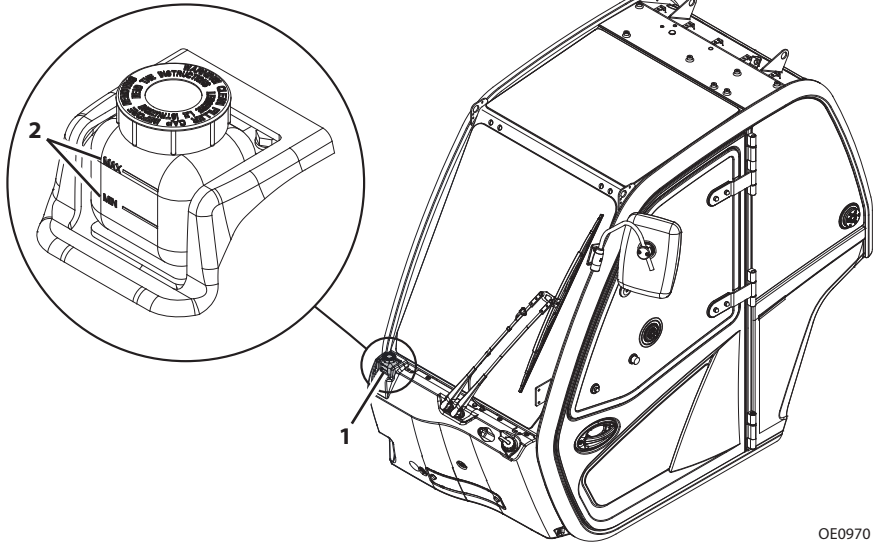

1. Perform "Shut-Down Procedure" on page 4-6.
2. Check the brake fluid level (1). Fluid should be between Max and Min (2) marks on brake reservoir.
3. If fluid is low, remove the product from service. See Service Manual for information.

Engine Cooling System

A. Engine Coolant Level Check

10 
OW0970

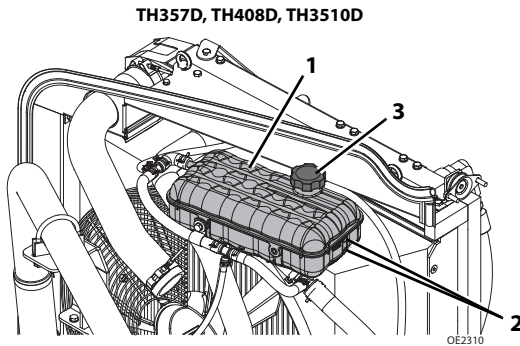
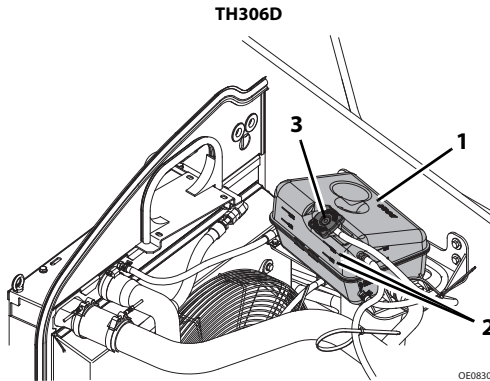

1. Perform "Shut-Down Procedure" on page 4-6.
2. Open engine cover.
3. Check coolant level in surge tank (1). Coolant should be between Max and Min (2) marks on surge tank.
4. If coolant is low, allow fluid to cool.
5. Remove surge tank cap (3) slowly. Add coolant as required.
6. Replace surge tank cap.
7. Close and secure engine cover.

Note: When filling coolant, maximum fill rate is 9,5 liter per minute (2.5 gallon per minute).

Section 7- Lubrication and Maintenance

Windshield Washer System (if equipped)

A. Windshield Washer Fluid Level Check

50 
OW0980

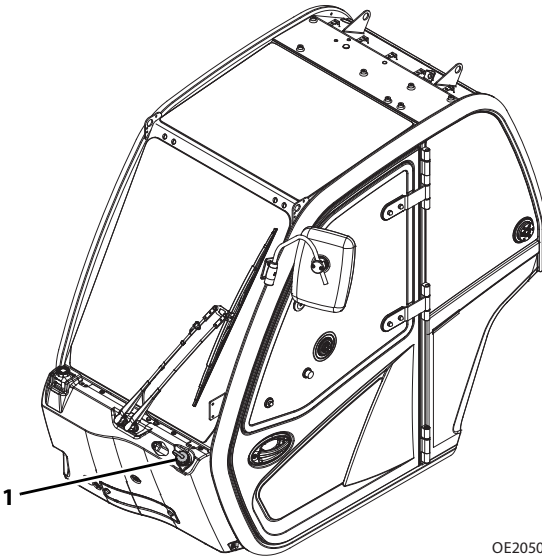

1. Perform "Shut-Down Procedure" on page 4-6.
2. Remove reservoir cap (1).
3. Windshield washer fluid should be visible in the reservoir.
4. If washer fluid level is low, add fluid as needed.
5. Replace reservoir cap.

This Page Intentionally Left Blank

Section 7- Lubrication and Maintenance

Cab Air Filters (if equipped)

A. Cab Air Filters Check

50 
OW0980

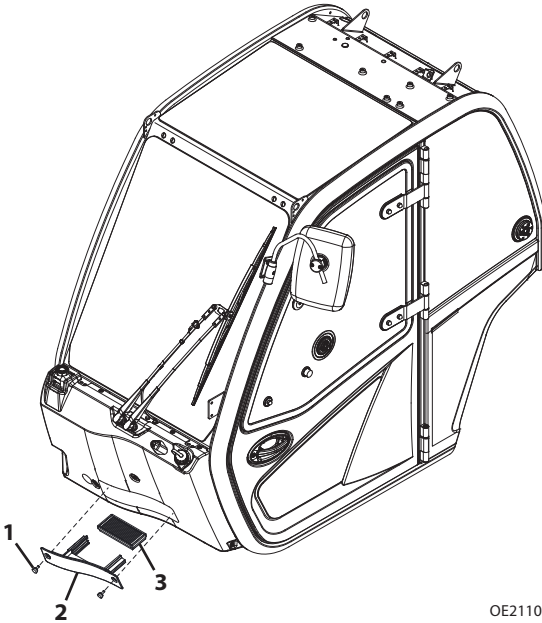

1. Perform "Shut-Down Procedure" on page 4-6.
2. Remove two thumb screws (1) and panel (2) from front of cab.
3. Remove filter (3) and inspect.
4. If filter is not damaged, clean and place back under dash. If damaged, replace filter.
5. Replace panel on front of cab and secure with thumb screws.

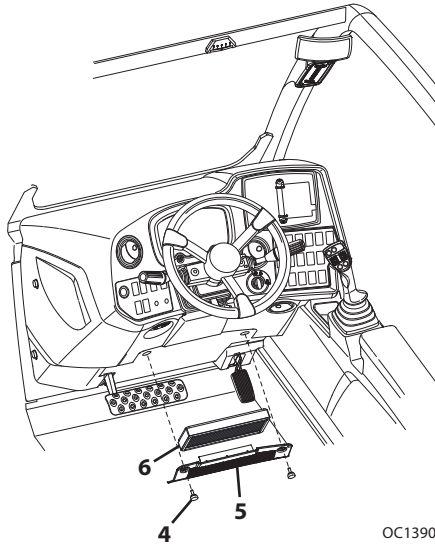

6. Remove two thumb screws (4) and panel (5) from under dash.
7. Remove cab air filter (6) and inspect.
8. If filter is not damaged, clean and place back under dash. If damaged, replace filter.
9. Replace panel and secure with thumb screws.

Section 7- Lubrication and Maintenance

Load Stability Indicator System

A. Load Stability Indicator System Check

50 
OW0980

OZ0840

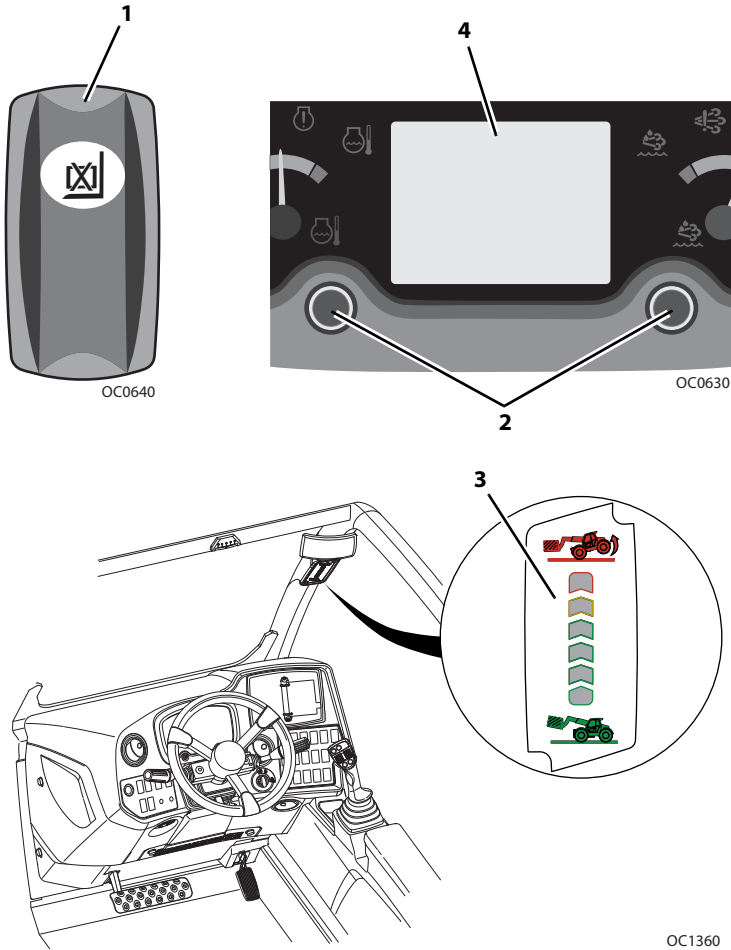

The Load Stability Indicator (LSI) is intended to continuously monitor the forward stability of the telehandler. To check this feature, perform the following:

1. Remove attachment, fully retract and fully raise boom and fully lower outriggers (if equipped).
2. Press and hold LSI override switch (1) on left control panel and the two control buttons (2) on instrument panel.

Section 7- Lubrication and Maintenance

3. LSI indicator LEDs (**3**) will illuminate sequentially then repeat if check is successful. LSI indicator LEDs will resume normal functionality when control buttons are released.
4. If check fails, a fault code will appear in the LCD display (**4**) and must be corrected before continued use. Repeat system check or re-calibrate machine. See Service Manual for LSI system calibration information.

Section 7- Lubrication and Maintenance

Jacking Up Machine

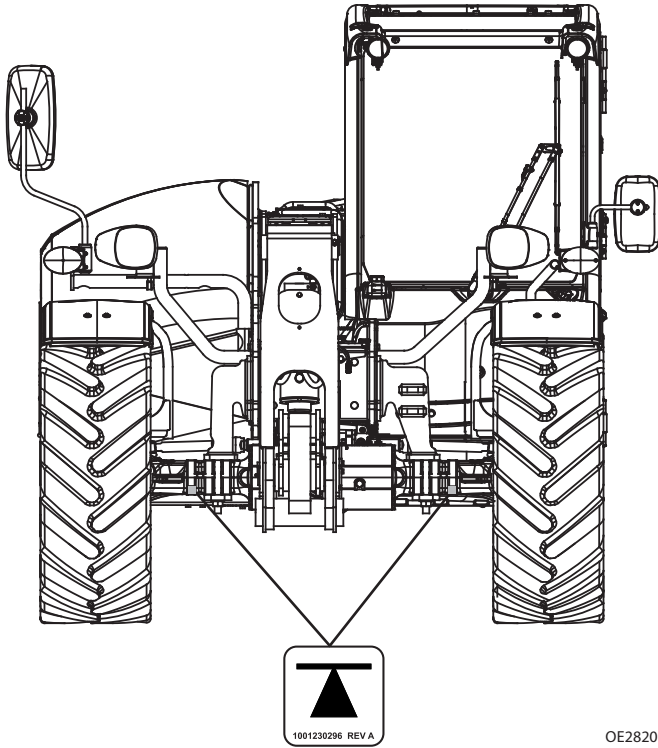

OE2820

Jack up machine at designated locations. Improper placement may damage machine or cause injury.

1. Ensure machine is parked on a solid, level surface.
2. Set the park brake and turn off engine.
3. Place wheel chocks on both sides of tires at end of machine that will not be jacked up.
4. Jack machine up at designated jack points located on both the front and rear axles. Use jack stands to support the machine.

SECTION 8 - ADDITIONAL CHECKS

8.1 GENERAL

If any of the following test results cannot be achieved, the system is not functioning properly and the machine must be removed from service and repaired before continued operation.

8.2 REVERSE SENSING SYSTEM (IF EQUIPPED)

A. Reverse Sensing System Check



Reverse Sensing System provides audible indication of objects to rear of unit while in reverse gear.

1. Clear all people and/or obstacles behind machine before performing Reverse Sensing System check.
2. Start machine and depress and hold brake. Place machine in reverse gear.
3. Verify alarm sounds upon system start up.

Note: Reverse Sensing System detects objects of size more than 232.25 square centimeters (36 square inches) area and is functional when machine is moving in reverse direction.

Note: The use of a construction cone or similar object must be used to test the Reverse Sensing System.



WARNING

CRUSH HAZARD. Do not use a person to test the reverse sensing system.

4. Verify operation with no objects in detection zone. No audible alarm.
5. Verify operation when object is in range of approximately 2.7 to 4.5 m (9 to 15 ft). Produces pulsing audible alarm at a frequency of one per second (1 Hz).
6. Verify operation when object is in range of approximately 2.1 to 2.7 m (7 to 9 ft). Produces pulsing audible alarm. Produces pulsing audible alarm at a frequency of two per second (2 Hz).
7. Verify operation when object is range of approximately 0.9 to 2.1 m (3 to 7 ft). Produces pulsing audible alarm at a frequency of four per second (4 Hz).
8. Verify operation when object is under approximately 0.9 m (3 ft) from machine. Produces pulsing audible alarm at a frequency of eight per second (8 Hz).

This Page Intentionally Left Blank

SECTION 9 - SPECIFICATIONS

9.1 PRODUCT SPECIFICATIONS

Fluids

SN TD200150 to Present, SN TA200150 to Present

Compartment or System	Type and Classification	Viscosities	Ambient Temperature Range			
			°F		°C	
			Min	Max	Min	Max
Engine Crankcase	Mobil Delvac 1 ESP	SAE 0W-40	-40	104	-40	40
		SAE 5W-40	-22	118	-30	48
Transmission Pump	CAT TDTO	SAE 50	50	122	10	50
		SAE 30	32	95	0	35
		SAE 10W	0	95	-20	35
		SAE 5W-30	-22	68	-30	20
		SAE 0W-30	-40	68	-40	20
Axle Differential and Wheel Ends	CAT Synthetic Gear Oil (GO)*	SAE 75W-140	-22	113	-30	45
	CAT Gear Oil (GO)*	SAE 85W-140	14	122	-10	50
		SAE 80W-90	-4	122	-20	50
	API GL5 with LS Additives	SAE140	50	122	10	50
		80W-140 85W-140	14	122	-10	50
		SAE90 SAE90LS	32	104	0	40
		80W-90	-4	104	-20	40
		75W-90	-40	104	-40	40
		75W	-40	50	-40	10
Hydraulic System	CAT TDTO CAT Arctic TDTO SYN commercial TO-4	SAE 15W-40	5	122	-15	50
		SAE 10W-30	-4	104	-20	40
		SAE 30	50	122	10	50
		SAE 10W	-4	104	-20	40
		SAE 5W-40	-22	104	-30	40
		SAE 5W-30	-22	104	-30	40
		SAE 0W-30	-40	104	-40	40
		SAE 0W-20	-40	104	-40	40
Boom Wear Pad Grease	Extreme Pressure Grease	NLGI Grade 000	-31	122	-35	50

Section 9- Specifications

Compartment or System	Type and Classification	Viscosities	Ambient Temperature Range			
			°F		°C	
			Min	Max	Min	Max
Grease Fittings	Extreme Pressure Grease	NLGI Grade 2 EP with Moly Additive or NLGI Grade 3 EP with Moly Additive	5	122	-15	50
Engine Coolant	CAT Extended Life Coolant (ELC)	50/50 Mix				
Fuel	EN590 ASTM D975 Grade 2-D ASTM D975 Grade 1-D (Maximum B5 Biodiesel)	Ultra Low Sulfur (S ≤ 15 mg/kg)				
Diesel Exhaust Fluid	ISO22241-1	32.5%Urea				
Brake Fluid	Mobil ATF 220		-40	122	-40	50
Air Conditioning	Refrigerant R-134-a	Tetrafluoroethane				

*Friction Modifier (197-0017) required for axle differentials. Must be pre-mixed with axle fluid.

Section 9- Specifications

SN TD300150 to Present, SN TA300150 to Present

Compartment or System	Type and Classification	Viscosities	Ambient Temperature Range			
			°F		°C	
			Min	Max	Min	Max
Engine Crankcase	CAT DEO-ULS	SAE 0W-30	-40	86	-40	30
		SAE 0W-40	-40	118	-40	48
		SAE 5W-30	-22	86	-30	30
		SAE 5W-40	-22	118	-30	48
		SAE 10W-30	0	104	-18	40
		SAE 10W-40	0	118	-18	48
		SAE 15W-40	15	118	-10	48
Transmission Pump	CAT TDTO	SAE 50	50	122	10	50
		SAE 30	32	95	0	35
		SAE 10W	0	95	-20	35
		SAE 5W-30	-22	68	-30	20
		SAE 0W-30	-40	68	-40	20
Axle Differential and Wheel Ends	CAT Synthetic Gear Oil (GO)*	SAE 75W-140	-22	113	-30	45
	CAT Gear Oil (GO)*	SAE 85W-140	14	122	-10	50
		SAE 80W-90	-4	122	-20	50
	API GL5 with LS Additives	SAE140	50	122	10	50
		80W-140 85W-140	14	122	-10	50
		SAE90 SAE90LS	32	104	0	40
		80W-90	-4	104	-20	40
		75W-90	-40	104	-40	40
75W	-40	50	-40	10		
Hydraulic System	CAT TDTO CAT Arctic TDTO SYN commercial TO-4	SAE 15W-40	5	122	-15	50
		SAE 10W-30	-4	104	-20	40
		SAE 30	50	122	10	50
		SAE 10W	-4	104	-20	40
		SAE 5W-40	-22	104	-30	40
		SAE 5W-30	-22	104	-30	40
		SAE 0W-30	-40	104	-40	40
		SAE 0W-20	-40	104	-40	40
Boom Wear Pad Grease	Extreme Pressure Grease	NLGI Grade 000	-31	122	-35	50

Section 9- Specifications

Compartment or System	Type and Classification	Viscosities	Ambient Temperature Range			
			°F		°C	
			Min	Max	Min	Max
Grease Fittings	Extreme Pressure Grease	NLGI Grade 2 EP with Moly Additive or NLGI Grade 3 EP with Moly Additive	5	122	-15	50
Engine Coolant	CAT Extended Life Coolant (ELC)	50/50 Mix				
Fuel	EN590 ASTM D975 Grade 2-D ASTM D975 Grade 1-D (Maximum B5 Biodiesel)	Low Sulfur (S ≤ 500 mg/kg)				
Brake Fluid	Mobil ATF 220		-40	122	-40	50
Air Conditioning	Refrigerant R-134-a	Tetrafluoroethane				

*Friction Modifier (197-0017) required for axle differentials. Must be pre-mixed with axle fluid.

Section 9- Specifications

**SN TD600150 to Present, SN TH900150 to Present, SN TH200150 to Present,
SN T7F00150 to Present**

Compartment or System	Type and Classification	Viscosities	Ambient Temperature Range			
			°F		°C	
			Min	Max	Min	Max
Engine Crankcase	CAT DEO ULS API CI-4	SAE 15W-40	14	122	-10	50
		SAE 10W-30	-4	104	-20	40
		SAE 0W-40	-40	118	-40	48
Transmission and Transfer Case	CAT TDTO	SAE 50	50	122	10	50
		SAE 30	32	95	0	35
		SAE 10W	0	95	-20	35
		SAE 5W-30	-22	68	-30	20
		SAE 0W-30	-40	68	-40	20
Axle Differential and Wheel Ends	CAT Synthetic Gear Oil (GO)*	SAE 75W-140	-22	113	-30	45
	CAT Gear Oil (GO)*	SAE 85W-140	14	122	-10	50
		SAE 80W-90	-4	122	-20	50
	API GL5 with LS Additives	SAE140	50	122	10	50
		80W-140 85W-140	14	122	-10	50
		SAE90 SAE90LS	32	104	0	40
		80W-90	-4	104	-20	40
		75W-90	-40	104	-40	40
		75W	-40	50	-40	10
Hydraulic System	CAT TDTO CAT Arctic TDTO SYN commercial TO-4	SAE 15W-40	5	122	-15	50
		SAE 10W-30	-4	104	-20	40
		SAE 30	50	122	10	50
		SAE 10W	-4	104	-20	40
		SAE 5W-40	-22	104	-30	40
		SAE 5W-30	-22	104	-30	40
		SAE 0W-30	-40	104	-40	40
		SAE 0W-20	-40	104	-40	40
Boom Wear Pad Grease	Extreme Pressure Grease	NLGI Grade 000	-31	122	-35	50

Section 9- Specifications

Compartment or System	Type and Classification	Viscosities	Ambient Temperature Range			
			°F		°C	
			Min	Max	Min	Max
Grease Fittings	Extreme Pressure Grease	NLGI Grade 2 EP with Moly Additive or NLGI Grade 3 EP with Moly Additive	5	122	-15	50
Engine Coolant	CAT Extended Life Coolant (ELC)	50/50 Mix				
Fuel	EN590 ASTM D975 Grade 2-D ASTM D975 Grade 1-D (Maximum B5 Biodiesel)	Ultra Low Sulfur (S ≤ 15mg/kg)				
Diesel Exhaust Fluid	ISO22241-1	32.5%Urea				
Brake Fluid	Mobil ATF 220		-40	122	-40	50
Air Conditioning	Refrigerant R-134-a	Tetrafluoroethane				

*Friction Modifier (197-0017) required for axle differentials. Must be pre-mixed with axle fluid.

Section 9- Specifications

**SN TD700150 to Present, SN TH400150 to Present, SN TH300150 to Present,
SN THZ00150 to Present**

Compartment or System	Type and Classification	Viscosities	Ambient Temperature Range			
			°F		°C	
			Min	Max	Min	Max
Engine Crankcase	CAT DEO API CI-4	SAE 15W-40	14	122	-10	50
		SAE 10W-30	-4	104	-20	40
		SAE 0W-40	-40	118	-40	48
Transmission and Transfer Case	CAT TDTO	SAE 50	50	122	10	50
		SAE 30	32	95	0	35
		SAE 10W	0	95	-20	35
		SAE 5W-30	-22	68	-30	20
		SAE 0W-30	-40	68	-40	20
Axle Differential and Wheel Ends	CAT Synthetic Gear Oil (GO)*	SAE 75W-140	-22	113	-30	45
	CAT Gear Oil (GO)*	SAE 85W-140	14	122	-10	50
		SAE 80W-90	-4	122	-20	50
	API GL5 with LS Additives	SAE140	50	122	10	50
		80W-140 85W-140	14	122	-10	50
		SAE90 SAE90LS	32	104	0	40
		80W-90	-4	104	-20	40
		75W-90	-40	104	-40	40
		75W	-40	50	-40	10
Hydraulic System	CAT TDTO CAT Arctic TDTO SYN commercial TO-4	SAE 15W-40	5	122	-15	50
		SAE 10W-30	-4	104	-20	40
		SAE 30	50	122	10	50
		SAE 10W	-4	104	-20	40
		SAE 5W-40	-22	104	-30	40
		SAE 5W-30	-22	104	-30	40
		SAE 0W-30	-40	104	-40	40
		SAE 0W-20	-40	104	-40	40
Boom Wear Pad Grease	Extreme Pressure Grease	NLGI Grade 000	-31	122	-35	50

Section 9- Specifications

Compartment or System	Type and Classification	Viscosities	Ambient Temperature Range			
			°F		°C	
			Min	Max	Min	Max
Grease Fittings	Extreme Pressure Grease	NLGI Grade 2 EP with Moly Additive or NLGI Grade 3 EP with Moly Additive	5	122	-15	50
Engine Coolant	CAT Extended Life Coolant (ELC)	50/50 Mix				
Fuel	EN590 ASTM D975 Grade 2-D ASTM D975 Grade 1-D (Maximum B5 Biodiesel)	Low Sulfur (S ≤ 500 mg/kg)				
Brake Fluid	Mobil ATF 220		-40	122	-40	50
Air Conditioning	Refrigerant R-134-a	Tetrafluoroethane				

*Friction Modifier (197-0017) required for axle differentials. Must be pre-mixed with axle fluid.

Capacities

Engine Crankcase Oil

Capacity with Filter Change

TH306D	8,0 L (8.5 qt)
TH357D, TH408D, TH3510D (3.4 Liter Engine)	9,0 L (9.5 qt)
TH357D, TH408D, TH3510D (4.4 Liter Engine)	8,8 L (9.3 qt)

Fuel Tank

Capacity

TH306D	106 L (28 gal)
TH357D, TH408D, TH3510D	145 L (38 gal)

Diesel Exhaust Fluid Tank

Capacity

TH306D	10 L (2.6 gal)
TH357D, TH408D, TH3510D	19 L (5.0 gal)

Cooling System

System Capacity

TH306D	21,5 L (22.7 qt)
TH357D, TH408D, TH3510D (3.4 Liter Engine, 83 KW)	17.4 L (18.4 qt)
TH357D, TH408D, TH3510D (4.4 Liter Engine, 92.6 & 106 KW).....	22.0 L (23.3 qt)
TH357D, TH408D, TH3510D (4.4 Liter Engine, 74.5 KW)	20.0 L (21.1 qt)
TH357D, TH408D, TH3510D (4.4 Liter Engine, 96.5 KW)	18.4 L (19.4 qt)

Hydraulic System

System Capacity 130 L (34.3 gal)

Reservoir Capacity to Full Mark

TH306D	98 L (25.9 gal)
TH357D, TH408D, TH3510D	97 L (25.6 gal)

Front Axle Drop Box (TH306D)

Capacity 1,8 L (1.9 qt)

Transmission System (TH357D, TH408D, TH3510D)

Capacity with Filter Change..... 14 L (14.8 qt)

Transfer Case (TH357D, TH408D, TH3510D)

Capacity 2,75 L (2.9 qt)

Section 9- Specifications

Axles

Differential Housing Capacity

TH306D

Front Axle

if utilizing fluid with LS Additives 4,2 L (4.4 qt)

if utilizing fluid without LS Additives* 3,99 L (4.2 qt)

Rear Axle 3,4 L (3.6 qt)

TH357D, TH408D, TH3510D

Front Axle

if utilizing fluid with LS Additives 6,15 L (6.5 qt)

if utilizing fluid without LS Additives* 5,84 L (6.2 qt)

Rear Axle

if utilizing fluid with LS Additives 7,5 L (7.9 qt)

if utilizing fluid without LS Additives* 7,125 L (7.5 qt)

**If axle fluid does not contain LS Additives, Friction Modifier must be added. Pre-mix before placing in axle differential. Not pre-mixing fluids can lead to excessive brake noise.*

Friction Modifier (if needed)

TH306D

Front Axle Not to Exceed 210 mL (7.1 oz)

Rear Axle None

TH357D, TH408D, TH3510D

Front Axle Not to Exceed 310 mL (10.5 oz)

Rear Axle Not to Exceed 375 mL (12.7 oz)

Wheel End Capacity

TH306D 0,85 L (0.9 qt)

TH357D, TH408D, TH3510D 1,61 L (1.7 qt)

Brake Fluid

Capacity 0,5 L (0.5 qt)

Air Conditioning System (if equipped)

System Capacity 1200 g (2.65 lb)

Tires

TH306D

405/70-20 MPT01	3,5 bar (51 psi)
400/70 R20 XMCL	4,0 bar (58 psi)
405/70-24 MPT01	4,0 bar (58 psi)
400/70 R24 XMCL	4,0 bar (58 psi)
400/70-24 POWER CL	5,0 bar (73 psi)

TH357D, TH408D, TH3510D

15.5/80-24	4,25 bar (62 psi)
15.5 R25 XHA TL	4,25 bar (62 psi)
460/70 R24 XMCL	4,0 bar (58 psi)
500/70 R24 XMCL	3,0 bar (44 psi)
440/80-24 POWER CL	3,5 bar (51 psi)
15.5-25 SGL	
Pneumatic	4,0 bar (58 psi)
Foam	264 kg (582 lb)
400/80-24 POWER CL	4,0 bar (58 psi)
370/75-28	5,25 bar (76 psi)
460/70 R24 BIBLOAD	4,0 bar (58 psi)

Wheel Lug Nut

Torque

TH306D (20 Inch Wheel)	300 ±20 Nm (221 ±15 lb-ft)
TH306D (24 Inch Wheel), TH357D, TH408D, TH3510D	460 ±20 Nm (340 ±15 lb-ft)

Section 9- Specifications

Performance

Maximum Lift Capacity

TH306D	2800 kg (6173 lb)
TH357D	3500 kg (7716 lb)
TH408D	4000 kg (8819 lb)
TH3510D	3500 kg (7716 lb)

Maximum Lift Height

TH306D	5800 mm (19.0 ft)
TH357D	7000 mm (23.0 ft)
TH408D	7610 mm (25.0 ft)
TH3510D	9800 mm (32.2 ft)

Capacity at Maximum Height

TH306D	2600 kg (5732 lb)
TH357D	2375 kg (5236 lb)
TH408D	2150 kg (4740 lb)
TH3510D	870 kg (1918 lb)

Maximum Forward Reach

TH306D	3100 mm (10.2 ft)
TH357D	3700 mm (12.1 ft)
TH408D	4276 mm (14.0 ft)
TH3510D	6600 mm (21.7 ft)

Capacity at Maximum Forward Reach

TH306D	1100 kg (2425 lb)
TH357D	1375 kg (3031 lb)
TH408D	1275 kg (2811 lb)
TH3510D	500 kg (1102 lb)

Reach at Maximum Height

TH306D	620 mm (2.0 ft)
TH357D	550 mm (1.8 ft)
TH408D	900 mm (3.0 ft)
TH3510D	1230 mm (4.0 ft)

Auxiliary Hydraulic Circuit Max Flow

TH306D	92 lpm (24.3 gpm)
TH357D, TH408D, TH3510D	100 lpm (26.4 gpm)

Maximum Travel Speed

TH306D	32 kph (19.9 mph)
TH357D, TH408D, TH3510D	40 kph (24.9 mph)

Section 9- Specifications

Maximum Travel Grade (boom in travel position)

Gradeability 45%

Side Slope 8.75%

Note: Refer to machine specific documents and/or plates for local governmental requirements and/or restrictions.

Section 9- Specifications

Dimensions

Note: Values will vary depending on machine configuration.

Maximum Overall Height

TH306D	2250 mm (88.6 in)
TH357D, TH408D, TH3510D	2475 mm (97.4 in)

Maximum Overall Width

TH306D	2100 mm (82.7 in)
TH357D, TH408D, TH3510D	2382 mm (93.8 in)

Maximum Track Width

TH306D	1672 mm (65.8 in)
TH357D, TH408D, TH3510D	1988 mm (78.3 in)

Wheel Base

TH306D	2770 mm (109.1 in)
TH357D, TH408D, TH3510D	3165 mm (124.6 in)

Length at Front Wheels

TH306D	3866 mm (152.2 in)
TH357D, TH408D, TH3510D	4433 mm (174.5 in)

Overall Length (no attachment)

TH306D	4400 mm (173.2 in)
TH357D	4972 mm (195.8 in)
TH408D	5258 mm (207.0 in)
TH3510D	5300 mm (208.7 in)

Ground Clearance

TH306D	390 mm (15.4 in)
TH357D, TH408D, TH3510D	429 mm (16.9 in)

Outside Turning Radius Over Tires

TH306D	3700 mm (145.7 in)
TH357D, TH408D, TH3510D	3847 mm (151.5 in)

Outside Turning Radius Over Forks

TH306D, TH357D	4400 mm (173.2 in)
TH408D	4525 mm (178.2 in)
TH3510D	4585 mm (180.5 in)

Maximum Operating Weight (no attachment)

TH306D	6300 kg (13,889 lb)
TH357D	8132 kg (17,928 lb)
TH408D	8712 kg (19,207 lb)
TH3510D	9287 kg (20,474 lb)

**Distribution of Maximum Operating Weight
(no attachment, boom level and fully retracted)****Front Axle**

TH306D	3000 kg (6,614 lb)
TH357D	4058 kg (8,946 lb)
TH408D	3985 kg (8,785 lb)
TH3510D.....	4273 kg (9,420 lb)

Rear Axle

TH306D	3300 kg (7,275 lb)
TH357D	4074 kg (8,982 lb)
TH408D	4727 kg (10,421 lb)
TH3510D.....	5014 kg (11,054 lb)

Maximum Ground Bearing Pressure**TH306D**

405/70-20 MPT01	Not Available at Publication
400/70 R20 XMCL	10,98 kg/cm ² (156.2 lb/in ²)
405/70-24 MPT01	Not Available at Publication
400/70 R24 XMCL	10,90 kg/cm ² (155.0 lb/in ²)
405/70-24 POWER CL.....	12,10 kg/cm ² (172.1 lb/in ²)

TH357D

15.5/80-24.....	10,04 kg/cm ² (142.8 lb/in ²)
15.5 R25 XHA TL.....	7,44 kg/cm ² (105.8 lb/in ²)
460/70 R24 XMCL	11,21 kg/cm ² (159.4 lb/in ²)
500/70 R24 XMCL	8,58 kg/cm ² (122.0 lb/in ²)
400/80-24 POWER CL.....	11,46 kg/cm ² (163.0 lb/in ²)
440/80-24 POWER CL.....	10,11 kg/cm ² (143.8 lb/in ²)
460/70 R24 BIBLOAD.....	8,74 kg/cm ² (124.3 lb/in ²)

TH408D

15.5/80-24.....	10,23 kg/cm ² (145.5 lb/in ²)
15.5 R25 XHA TL.....	7,41 kg/cm ² (105.4 lb/in ²)
460/70 R24 XMCL	11,48 kg/cm ² (163.3 lb/in ²)
500/70 R24 XMCL	8,76 kg/cm ² (124.6 lb/in ²)
400/80-24 POWER CL.....	11,65 kg/cm ² (165.7 lb/in ²)
440/80-24 POWER CL.....	10,27 kg/cm ² (146.1 lb/in ²)
460/70 R24 BIBLOAD.....	8,96 kg/cm ² (127.4 lb/in ²)

TH3510D

15.5/80-24.....	10,65 kg/cm ² (151.5 lb/in ²)
15.5 R25 XHA TL.....	7,51 kg/cm ² (106.8 lb/in ²)
460/70 R24 XMCL	12,00 kg/cm ² (170.7 lb/in ²)
500/70 R24 XMCL	9,12 kg/cm ² (129.7 lb/in ²)
400/80-24 POWER CL.....	12,06 kg/cm ² (171.5 lb/in ²)
440/80-24 POWER CL.....	10,58 kg/cm ² (150.5 lb/in ²)
460/70 R24 BIBLOAD.....	9,42 kg/cm ² (134.0 lb/in ²)

Section 9- Specifications

Declaration of Vibration

According to Directive 78/764/EEC and Regulation (EU) No 1322/2014, Annex XIV

Seat*	Weighted Seat Vibration Acceleration (a_{ws})	
	Light Driver	Heavy Driver
503-1691	1,18 m/s ²	1,01 m/s ²
476-7798	1,18 m/s ²	1,01 m/s ²
476-7796	1,18 m/s ²	1,01 m/s ²
476-8930	1,13 m/s ²	1,01 m/s ²
503-1690	1,14 m/s ²	1,06 m/s ²

According to Standard EN13059

Seat*	Average Weighted Whole Body Acceleration	
	TH306D	TH357D, TH408D, TH3510D
Mechanical Suspension	0,5 m/s ² (1.6 ft/s ²)	0,387 m/s ² (1.3 ft/s ²)
Pneumatic Suspension	0,5 m/s ² (1.6 ft/s ²)	0,298 m/s ² (1.0 ft/s ²)

**A seat is an essential means to reduce the vibration transmitted to the operator. In case of replacement of the seat, refer to the manufacturer.*

Noise Emission Level (CE)

Note: To avoid any increase in noise emission, after maintenance and repair work, all panels and other sound absorbing materials must be replaced in their original condition. Do not modify the machine in such a manner as to increase noise emissions

L_{WA} is A-weighted emission sound power level

L_{pA} is A-weighted emission sound pressure level

According to Directive 2000/14/EC (Outdoor Noise) & EN 12053 (Operator Noise)

Model	Net Power:	2000/14/EC	EN 12053
TH306D TH357D TH408D TH3510D	≤90,0 kW	106 dB(A) L_{WA}	<80 dB(A) L_{pA}
TH306D TH357D TH408D TH3510D	>90,0 kW	107 dB(A) L_{WA}	<80 dB(A) L_{pA}

According to Regulation (EU) No 1322/2014, Annex XIII (Operator Noise)

Model	Windows Closed	Windows Open
TH306D TH357D TH408D TH3510D	79.7 dB(A) L_{pA}	78.5 dB(A) L_{pA}

Section 9- Specifications

Machine Towing Capacity

Note: Refer to machine specific documents and/or plates for local governmental requirements and/or restrictions.

Unbraked.....	3000 kg (6,614 lb)
Hydraulic or Pneumatic Braked	
TH306D	8000 kg (17,637 lb)
TH357D, TH408D, TH3510D	12000 kg (26,455 lb)

According to Directive 2010/52/EU

TH306D

Tires	Maximum Mass per Axle (kg)		Hitch Load	
	32 km/h	40 km/h	32 km/h	40 km/h
400/70 R20 XMCL	5607	N/A	1750	N/A
405/70-20 MPT01	5607	N/A	1750	N/A
400/70 R24 XMCL	N/A	6116	N/A	1750
400/70 R24 POWER CL	N/A	6116	N/A	1750
405/70-24 MPT01	N/A	6116	N/A	1750

TH357D, TH408D

Tires	Maximum Mass per Axle (kg)		Hitch Load TH357D		Hitch Load TH408D	
	30 km/h	40 km/h	30 km/h	40 km/h	30 km/h	40 km/h
	15.5/80-24	8700	7900	2500	2500	2500
15.5 R25 XHA TL	9000	8200	2500	2500	2500	2500
460/70 R24 XMCL	9000	8100	2500	2500	2500	2500
500/70 R24 XMCL	8000	7800	2500	2500	2500	2500
400/80-24 POWER CL	8200	7900	2500	2500	2500	2500
440/80-24 POWER CL	8700	8100	2500	2500	2500	2500
460/70 R24 BIBLOAD	9000	8100	2500	2500	2500	2500

TH3510D

Tires	Maximum Mass per Axle (kg)		EEC Manual Hitches Hitch Load		Fixed Height & Hydraulic Hitches Hitch Load	
	30 km/h	40 km/h	30 km/h	40 km/h	30 km/h	40 km/h
	15.5/80-24	8700	7900	2500	2400	2500
15.5 R25 XHA TL	9000	8200	2500	2500	2500	2500
460/70 R24 XMCL	9000	8100	2500	2500	2500	2500
500/70 R24 XMCL	8000	7800	2500	2400	2500	2400
400/80-24 POWER CL	8200	7900	2500	2400	2500	2500
440/80-24 POWER CL	8700	8100	2500	2500	2500	2500
460/70 R24 BIBLOAD	9000	8100	2500	2500	2500	2500

This Page Intentionally Left Blank

A	C
Accessory Control Lever..... 3-20	Cab Air Filters 7-36
Additional Checks 8-1	Capacity 5-5
Adjusting/Moving Forks 5-21	Capacity Chart
After-Treatment System..... 4-8	Example 5-10
Air Cleaner..... 7-24	Sample (AUS) 5-8
Approved Attachments..... 5-1	Sample (CE) 5-7
Attachment Installation	Capacity Indicator Locations 5-6
Hydraulic Coupler 5-13	Carriage w/Forks..... 5-23
JCB Coupler 5-18	Chemical Hazards..... 1-14
JD Coupler 5-14	Controls..... 3-2
Manitou Coupler..... 5-16	Coolant Level 7-33
Mechanical Coupler..... 5-12	Cooling System 9-9
Attachment Operation 5-22, 5-62	Coupler Mounted Hook 5-56
Attachments..... 5-1	
JLG Supplied 5-2	D
Auger 5-50	DEF Tank..... 9-9
Axles 9-10	Diesel Emission Fluid (DEF) Level 7-22
	Dimensions..... 9-14
B	Disengaging a Load..... 4-12
Bale Handler 5-36	Disengaging a Suspended Load 4-15
Battery Boosted Starting..... 4-3	Driving Hazards on Slopes 1-10
Battery Hazards 1-15	Dual Tine Bale 5-34
Boom Indicator	
Angle..... 3-41	E
Extension 3-41	EEC Auto Hitch 5-68
Boom Ride Control..... 3-11	EEC Manual Pin Hitch..... 5-67
Brake Fluid..... 7-32, 9-10	Electrical Hazards 1-2
Bucket 5-38	Emergency Exit from Enclosed Cab 6-3
	Emergency Lowering of Boom 6-2
	Emergency Procedures 6-1
	Engine
	Extreme Cold Weather Starting 4-2
	Normal Operation 4-5
	Starting 4-1
	Engine Crankcase Oil..... 9-9
	Engine Hood 2-17
	Engine Oil Level 7-23
	Exit 6-3

Index

F

Fall Hazard	1-13
Fixed Hitch.....	5-64
Fluids.....	9-1
Capacities.....	9-9
Fork Extension	5-30
Fork Mounted Hook	5-58
Fork Positioning Carriage.....	5-24
Fork Rotator Carriage.....	5-26
Front Axle Drop Box	9-9
Fuel Level	7-20
Fuel Tank	9-9
Fuel/Water Separator.....	7-21

G

General Maintenance	7-2
Grapple Bucket.....	5-42

H

Hazard Classification System	1-1
Hitches	5-62
Hydraulic Hitch.....	5-70
Hydraulic Oil Level	7-28
Hydraulic Operated Attachment	5-20
Hydraulic System.....	9-9

I

Ignition.....	3-16
Instrument Panel.....	3-4

J

Jacking Up Machine	7-40
Joystick.....	3-26
Lift Pattern	3-26
Loader Pattern	3-30

L

Leveling Procedure	4-11, 4-14
Lifting Personnel	1-9
Load Falling Hazard.....	1-8
Load Stability Indicator - LSI.....	3-22
LSI System Check	7-38
Lubrication and Maintenance	7-1
Lubrication Schedule	
TH306D	7-12
TH357D, TH408D, TH3510D	7-13

M

Manure Grapple.....	5-44
Muck Fork	5-46, 5-52
Multi-Purpose Bucket	5-40

N

Noise Emission	9-17
----------------------	------

O

Operating with a Non-Suspended Load	3-6, 4-9, 4-10
Operating with a Suspended Load.....	4-13
Operational Check.....	2-13
Operator Cab	2-14
Operator Maintenance Instructions.....	7-15
Operator Presence	3-36
Operator Seat	3-36
Adjustments	3-37

P	
Park Brake.....	3-17
Parking Procedure.....	3-17
Performance.....	9-12
Picking Up a Load.....	4-10
Picking Up a Suspended Load	4-13
Pin Hitch - CUNA C	5-65
Pin Hitch - CUNA D2	5-66
Pinch Points and Crush Hazards	1-11
Pipe Grapple.....	5-32
Piton Hitch	5-69
Placing a Load.....	4-12
Placing a Suspended Load	4-15
Pre-Operation Check and Inspection.....	2-2
R	
Rear Auxiliary Hydraulics	5-71
Retrieval Hitch	5-63
Reverse Sensing System	3-42
Reversing Camera	3-42, 3-44
Reversing Fan Switch	3-21
S	
Safety Practices	1-1
Safety Signal Words	1-1
Seat Belt	3-40
Service and Maintenance Schedule	
10 Hour (TH306D)	7-3
10 Hour (TH357D, TH408D, TH351D).....	7-7
1000 Hour (TH306D).....	7-5
1000 Hour (TH357D, TH408D, TH3510D)	7-9
12000 Hour (TH357D, TH408D, TH3510D)	7-11
1500 Hour (TH306D).....	7-6
1500 Hour (TH357D, TH408D, TH3510D)	7-10
1st 250 Hour (TH306D).....	7-4
1st 250 Hour (TH357D, TH408D, TH3510D)	7-8
1st 50 Hour (TH306D)	7-3
1st 50 Hour (TH357D, TH408D, TH351D).....	7-7
2000 Hour (TH306D)	7-6
2000 Hour (TH357D, TH408D, TH3510D)	7-10
250 Hour (TH306D).....	7-4
250 Hour (TH357D, TH408D, TH3510D)	7-8
3000 Hour (TH306D)	7-6
3000 Hour (TH357D, TH408D, TH3510D)	7-10
50 Hour (TH306D)	7-4
50 Hour (TH357D, TH408D, TH3510D)	7-8
500 Hour (TH306D).....	7-5
500 Hour (TH357D, TH408D, TH3510D)	7-9
6000 Hour (TH357D, TH408D, TH3510D)	7-11
750 Hour (TH306D).....	7-5
750 Hour (TH357D, TH408D, TH3510D)	7-9
Shut-Down Procedure.....	4-6
Side Shift Carriage.....	5-28
Side Tilt Carriage.....	5-26
Specifications.....	9-1
Steering Alignment Mode	
All Wheel Assisted.....	3-35
Manual	3-34
Steering Column Adjuster.....	3-24
Sweeper	5-48

Index

T

Tip Over Hazard	1-4
Tires	7-26, 9-11
Air Pressure	7-26
Damage	7-26
Replacement.....	7-26
Towing	6-1
Towing Capacity	9-18
Trailer Brakes.....	5-62, 5-72
Transmission Control	
Direction of Travel	3-18
Gear Selection	3-19
Transmission Oil Level.....	7-30
Transmission System	9-9
Transport	
Lifting	4-18
Tie Down	4-17
Transporting a Load	4-11
Transporting a Suspended Load	4-14
Trash Hopper—Fork Mounted.....	5-60
Travel Hazard	1-7
Truss Boom	5-54



V

Vibration	9-16
-----------------	------

W

Warm-Up Check.....	2-13
Wheel Installation	7-27
Wheel Lug Nut.....	9-11
Wheel Replacement	7-26
Windshield Washer Fluid Level	7-34

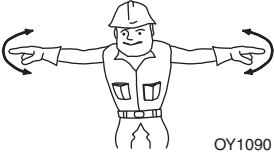
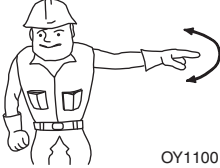
Hand Signals

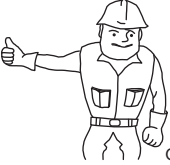
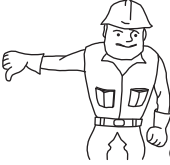
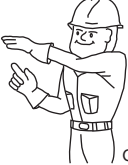
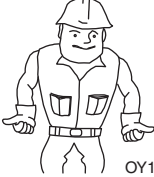
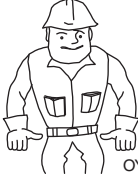
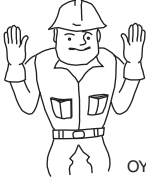
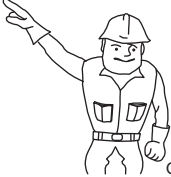
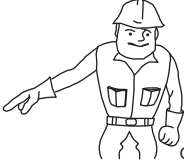
 <p>OY1090</p> <p>EMERGENCY STOP - With both arms extended laterally, hands open downward, move arms back and forth.</p>	 <p>OY1100</p> <p>STOP - With either arm extended laterally, hand open downward, move arm back and forth.</p>	 <p>OY1110</p> <p>STOP ENGINE - Draw thumb or forefinger across throat.</p>
 <p>OY1120</p> <p>RAISE BOOM - With either arm extended horizontally, fingers closed, point thumb upward.</p>	 <p>OY1130</p> <p>LOWER BOOM - With either arm extended horizontally, fingers closed, point thumb downward.</p>	 <p>OY1140</p> <p>MOVE SLOWLY - Place one hand motionless in front of hand giving motion signal. (Raise load slowly shown)</p>
 <p>OY1150</p> <p>EXTEND BOOM - With both hands clenched, point thumbs outward.</p>	 <p>OY1160</p> <p>RETRACT BOOM - With both hands clenched, point thumbs inward.</p>	 <p>OY1170</p> <p>THIS FAR TO GO - With hands raised and open inward, move hands laterally, indicating distance to go.</p>
 <p>OY1180</p> <p>TILT FORKS UP - With one arm held at side, extend other arm upward at about 45 degrees.</p>	 <p>OY1190</p> <p>TILT FORKS DOWN - With one arm held at side, extend other arm downward at about 45 degrees.</p>	

Special Signals - When signals for auxiliary equipment functions or conditions not covered are required, they shall be agreed upon in advance by the operator and signalman.



31211089

CATERPILLAR®