

CN1566

Cat® Electric Motor for Gas Compression

1500 bhp

Dimensions

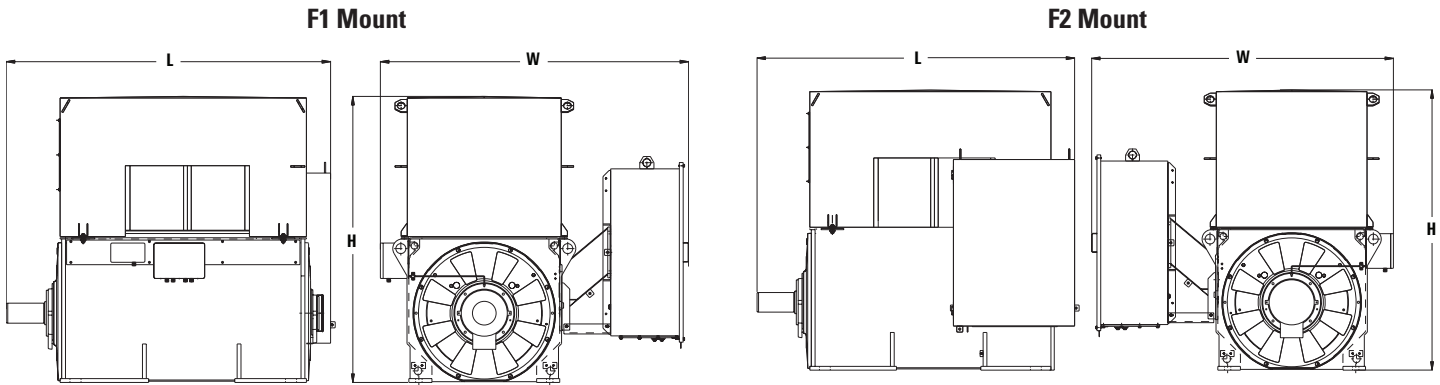

Standard Terminal Box Shown

Length.....	83.07 in (2110 mm)
Width.....	78.94 in (2005 mm)
Height.....	73.23 in (1860 mm)
Weight.....	8289 lb (3760 kg)

approximate dimensions

Performance Curves

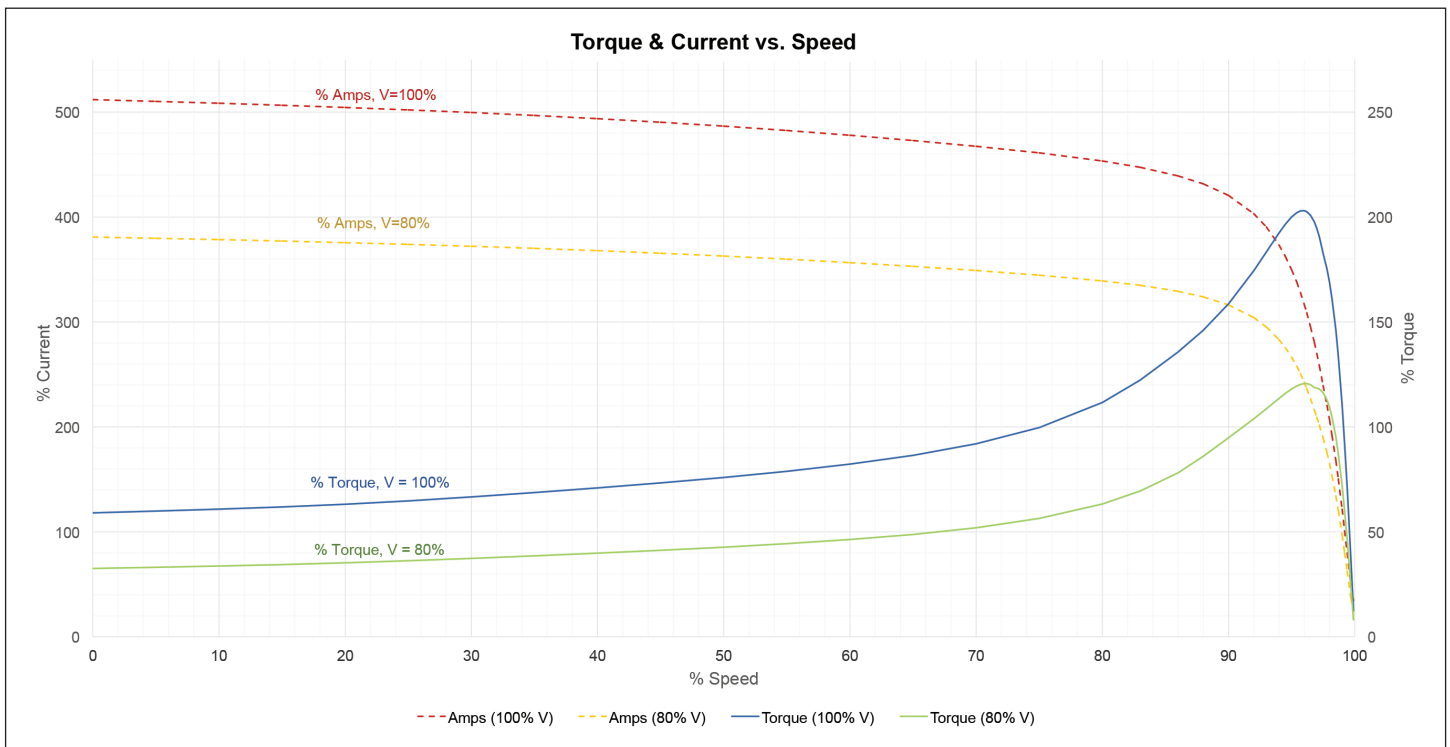

Performance Curves continued

