



3516C (HD) Offshore Generator Set

1530 kW (2186 kVA)
60 Hz (1200 rpm)

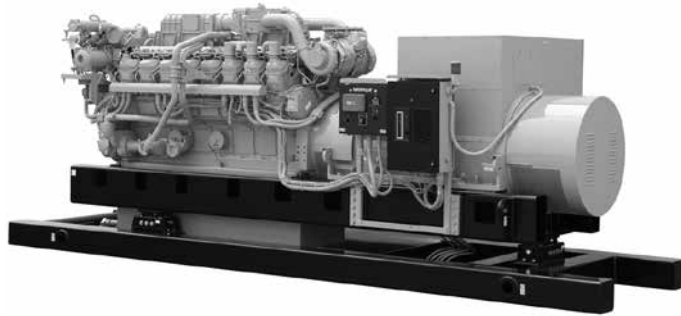

Image shown with optional attachments.

CAT® ENGINE SPECIFICATIONS

V-16, 4-Stroke-Cycle-Diesel

Emissions	EPA Marine Tier 2, IMO Tier II
Bore	170 mm (6.7 in)
Stroke	215 mm (8.5 in)
Displacement	78 L (4764 in ³)
Aspiration	Turbocharged-Aftercooled
Fuel System	EUI™
Engine Control	ADEM™ A3
Instrumentation	Marine Power Display
Oil Change Interval	1000 hours

FEATURES

Engine Design

- Proven reliability and durability
- Robust diesel strength design prolongs life and lowers owning an operating costs
- Assembled, tested, and validated as a package to minimize package vibration and maximize component life
- Market-leading power density
- Long overhaul life proven in oilfield applications
- Core engine components designed for reconditioning and reuse at overhaul

Ease of Installation

Engine and generator are mounted to an inner base, which mounts to an outer base assembly with vibration isolators. Installed with an integral drip tray to provide a single lift installation and to reduce the shipyard scope of work complexity.

Safety

- E-stop pushbutton on instrument panel
- Air shutoff and explosion relief valves
- Configurable alarm and shutdown features
- Extra alarm switches available for customer-supplied panel

Improved Serviceability

Large inspection openings allow convenient access to core engine internals

Reduction of Owning and Operating Costs

- Long filter change intervals, aligned with service intervals
- Excellent fuel economy — direct injection electronic unit injectors precisely meter fuel

Custom Packaging

For any petroleum application, trust Caterpillar to meet your exact needs with a factory custom package. Cat® engines, generators, enclosures, controls, radiators, transmissions — anything your project requires — can be custom designed and matched to create a one-of-a kind solution. Custom packages are globally supported and are covered by a one-year warranty after startup.

Testing

Every Cat engine is full-load tested to ensure proper engine performance.

Product Support Offered Through Global Cat Dealer Network

More than 2,200 dealer outlets

Caterpillar factory-trained dealer technicians service every aspect of your petroleum engine

Caterpillar parts and labor warranty

Preventive maintenance agreements available for repair-before-failure options

S•O•SSM program matches your oil and coolant samples against Caterpillar set standards to determine:

- Internal engine component condition
- Presence of unwanted fluids
- Presence of combustion by-products
- Site-specific oil change interval

Over 80 Years of Engine Manufacturing Experience

Ownership of these manufacturing processes enables Caterpillar to produce high quality, dependable products.

- Cast engine blocks, heads, cylinder liners, and flywheel housings
- Machine critical components
- Assemble complete engine

Web Site

For all your petroleum power requirements, visit www.catoilandgasinfo.com.



STANDARD AND OPTIONAL EQUIPMENT

Air Inlet System

Standard

Aftercooler core, corrosion resistant coating (air side)
Air cleaner, regular duty with soot filter
Dual turbochargers, 152 mm (6 in) OD straight connection
Service indicators

Optional

Remote air inlet adapters

Control System

Standard

Caterpillar ADEM A3 electronic engine control, LH
Requires 24V DC 10 amp continuous, 20 amp intermittent,
clean electric power

Optional

Direct rack control interface, 0-200 mA DC control
Load sharing module

Cooling System

Standard

Configuration for remote or engine-mounted radiators
Separate circuit aftercooler (SCAC) with thermostat control
Jacket water cooling circuit (JW) with thermostat control
Gear-driven centrifugal pumps, one for each circuit
Engine oil cooler in JW circuit

Optional

Air separator
Custom radiator
Plate-type heat exchanger

Note: To ensure emissions and engine performance,
optional or customer-supplied radiators or heat
exchangers must be capable of rejecting enough heat
for proper operation at worse-case site conditions.

Exhaust System

Standard

Dry, gas-tight exhaust manifolds with thermo-laminated
heat shields
Dual turbochargers with thermo-laminated heat shields
Flexible exhaust fitting/weldable exhaust flange

Optional

Thermocouples
Flexible exhaust fittings
Exhaust elbows
Muffler – 356 mm (14 in)
Muffler – 406 mm (16 in)
Muffler – 356 mm (14 in); spark arresting
Muffler – 406 mm (16 in); spark arresting

Flywheels and Flywheel Housings

Standard

Flywheel, SAE No. 00, 183 teeth
Flywheel housing, SAE No. 00

Optional

Flywheel guard
Flexible coupling
Coupling hub

Fuel System

Standard

Fuel filter, LH
Fuel transfer pump
Fuel priming pump, LH
Mechanically-actuated, electronically-controlled unit
injectors

Optional

Duplex fuel filter
Fuel level switch
Fuel priming pump, RH
Primary fuel filter
Water separator

Generator and Attachments

Standard

Custom generator

Optional

Air filter
Single-point connection terminal box
Cable access box

Instrumentation

Standard

Marine Power Display – 178 mm (7 in) color monitor
Analog or digital display of:
Engine oil pressure
Engine water temperature
Fuel pressure
System DC voltage
Air inlet restriction
Exhaust temperature
Fuel filter differential
Oil filter differential
Service meter
Engine speed
Instantaneous fuel consumption
Total fuel consumed
Engine control switch (4-position)
Prioritized alarms
Overspeed shutdown notification light
Pre-lube override
Shutdown override

Optional

Communication module PL1000T
Communication module PL1000E
Metal particle detector annunciator
Discrete I/O module
Remote cylinder temperature display
Oil temperature sensor
Oil pressure switch
Intake manifold temperature sensors
Water temperature switch
Water level switch



STANDARD AND OPTIONAL EQUIPMENT CONTINUED

Lubrication System

Standard

- Crankcase breather, top-mounted
- Oil cooler in JW system
- Oil filter, simplex, LH
- Oil filler and dipstick, LH
- Oil pan, 1000-hour oil change interval
- Oil pump, gear-type
- Oil pan drain valve, 2 in NPT female connection

Optional

- Oil filter, duplex
- Centrifugal oil filter
- Oil pan and dipstick, 15 degree tilt capability
- Oil pan and dipstick, 25 degree tilt capability
- Air prelube
- Electric prelube
- Manual prelube
- Oil level regulator
- Emergency lube oil connections
- Sump pump
- Drip tray

Mounting System

Note: For use with Caterpillar or other manufacturers' generators

Standard

- Inner base with three-point mounting to outer base
- Maintains engine/generator alignment on uneven surfaces
- Engine length drip pan
- Oil drain extension
- Lifting provisions on base

Optional

- Custom bases
- Vibration isolators

Power Take-Offs

Optional

- Alternator drive
- Auxiliary drive shafts and pulleys
- Front stub shaft
- Crankshaft pulley

Protection System

Standard

- ADEM A3 monitoring system provides engine deration, alarm and shutdowns
- Selected customer-programmable parameters
- Pushbutton emergency stop on instrument panel
- Alarm switches (oil pressure and water temperature for PL1000, unwired)

Optional

- Spray shielding
- Crankcase explosion relief valves
- Metal particle detector

Starting System

Standard

- Air starting motor, RH, 620-1034 kPA (90-150 psi), LH control
- Air silencer

Optional

- Air pressure regulator
- Battery set
- Charging alternator
- Electric starter
- Jacket water heater
- Redundant start with select switch

General

Standard

- Paint, Caterpillar yellow with black rails
- Vibration damper and guard
- Engine lifting eyes

Optional

- Engine spare parts kit



TECHNICAL DATA

3516C (HD) Offshore Generator Set — 1200 rpm

	Units	DM8421
Generator Set Data		
Rated power	ekW	1530
kVA rating	kVA	2186
Rated power factor		0.7
Frequency	Hz	60
Engine Data		
Engine power	bkW (bhp)	1603 (2150)
Engine speed	rpm	1200
Maximum ambient temperature without derate	°C (°F)	60 (140)
BMEP @ rated	kPa (psi)	2053 (298)
BSFC @ 100% load	g/bkW-hr (lb/bhp-hr)	210 (0.35)
BSFC @ 75% load	g/bkW-hr (lb/bhp-hr)	219 (0.36)
BSFC @ 50% load	g/bkW-hr (lb/bhp-hr)	225 (0.37)
BSFC @ 25% load	g/bkW-hr (lb/bhp-hr)	252 (0.42)
Fuel consumption @ rated (nominal)	L/hr (gal/hr)	401.8 (106)
Air flow rate (@25°C, 101.3 kPa)	m ³ /min (ft ³ /min)	139 (4905)
Inlet manifold pressure	kPa (psi)	268 (38.9)
Inlet manifold temperature	°C (°F)	58.6 (137)
Aftercooler water temperature	°C (°F)	50 (122)
Jacket water temperature	°C (°F)	99 (210)
Exhaust stack temperature	°C (°F)	436 (816)
Exhaust flow rate (@stack temp, 101.3 kPa)	m ³ /min (ft ³ /min)	345 (12,176)
Separate circuit afercooler heat rejection @ rated	kW (Btu/min)	442 (25,136)
Separate circuit afercooler water flow @ rated	L/min (gal/min)	0
Jacket water heat rejection @ rated	kW (Btu/min)	618 (35,144)
Jacket water flow @ rated	L/min (gal/min)	0
Radiated/convective heat rejection @ rated	kW (Btu/min)	133 (7563)
Lube oil system capacity	L (gal)	405 (107)
Engine coolant capacity	L (gal)	234.7 (62)
Oil change interval	Hours	1000
Generator Data		
Generator model		Kato 6P6.6-3200 HR
Voltage	Volts	600
Design kVA rating	kVA	2619
Insulation class		F
Temperature rise (@ 50°C ambient temp)	°C	90
Max overspeed		125%/60 sec
Excitation		PM
Number of poles		6
Winding		Form wound
Pitch		0.778
Number of leads		6
Number of bearings		2
Ingress protection rating		IP44
Alignment		Close coupled
Space heater	Volts	120/240
Stator RTDs per phase		2
Bearings RTDs		2



3516C (HD) OFFSHORE GENERATOR SET

1530 ekW 60 Hz

DIMENSIONS

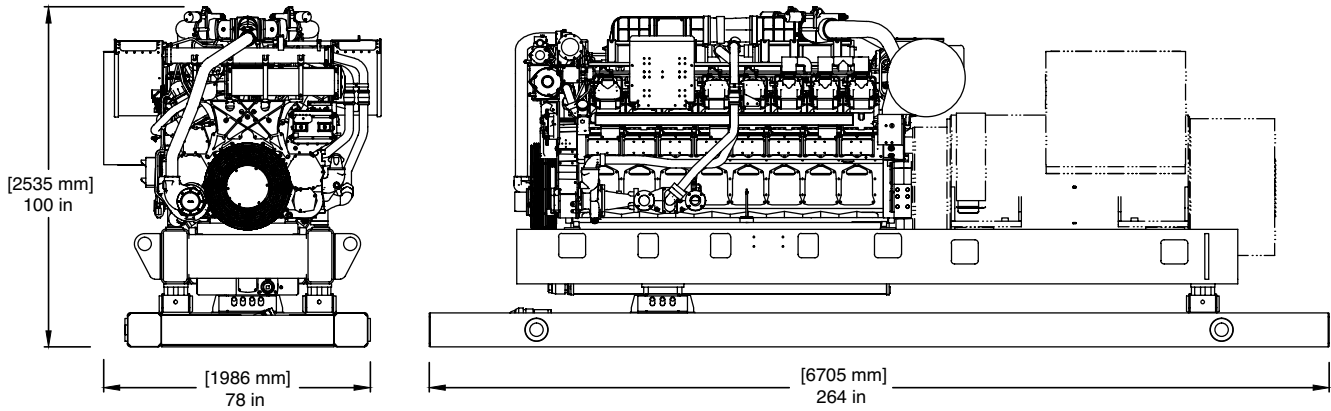

Dimensions and Weight		
Length	6705 mm	264 in
Width	1986 mm	78 in
Height	2535 mm	100 in
Weight – dry	18 800 kg	41 400 lb

Note: Dimensions are dependent on generator and options selected. See general installation drawings for detail.

Note: Weight includes engine, generator, base, coupling, and all auxiliary components. Weight may vary depending upon individual configuration.

RATING DEFINITIONS AND CONDITIONS

Rating Definition — Maximum Continuous Rating (MCR) following reference conditions according to the International Association of Classification Societies (IACS) for main and auxiliary engines. An overload of 10% is permitted for one hour within 12 hours of operation.

Conditions are based on SAE J1995 standard conditions of 100 kPa (29.61 in Hg) and 25°C (77°F). These ratings also apply at ISO3046/1, DIN6271, and BS5514 standard conditions of 100 kPa (29.61 in Hg), 27°C (81°F), and 60% relative humidity.

Fuel Consumption — 5% tolerance and based on fuel oil of 35° API [16°C (60°F)] gravity having an LHV of 62 780 kJ/kg (18,390 Btu/lb) when used at 29°C (85°F) and weighing 838.9 g/liter (7.001 lbs/U.S. gal). Fuel consumption is shown with all engine-driven oil, fuel, and water pumps.

Information contained in this publication may be considered confidential. Discretion is recommended when distributing. Materials and specifications are subject to change without notice. The International System of Units (SI) is used in this publication. CAT, CATERPILLAR, their respective logos, ADEM, EUI, S•O•S, "Caterpillar Yellow" and the "Power Edge" trade dress, as well as corporate and product identity used herein, are trademarks of Caterpillar and may not be used without permission.