

793

MINING TRUCK



Engine:	C175-16
Gross Power – SAE J1995:	1 976 kW / 2,650 HP
Gross Weight:	386 007 kg / 851,000 lb 404 000 kg / 890,668 lb
Nominal Payload:	230-240 tonnes / 254-265 tons



CAT® MINING TRUCKS
**YOUR PARTNER
FOR THE
LONG HAUL**

Cat® Mining Trucks have been around for generations, and each new class brings cutting-edge technology built on a foundation of industry leadership. The longevity of Cat mining trucks is no mystery. It's a product of purpose-driven engineering, intense customer focus and technology that meets today's industry requirements. They're built to be rebuilt and here for the long haul.





What can you expect from your Cat mining truck?
The lowest cost per ton over its life.

A lot goes into delivering that value. Like high speed on grade for improved productivity. A class-leading standard payload. Anytime braking plus front and rear wheel resistive braking (retarding) for more confident operators. Total Cat integration, which results in highly efficient systems and performance. And high reliability, so trucks spend more time hauling material than they do sitting in the maintenance shop.

With a truck for every site and application—no matter the size class or drive system—and a broad lineup of loading tools, Caterpillar offers a complete loading and hauling solution that delivers a better bottom line to the most important mine in the world: yours.

THE NEXT GENERATION OF PRODUCTIVE HAULING

The Cat 793 is designed to be the most efficient and productive truck available in its size class. If there was one word to describe the hundreds of improvements we've made in our products, it would be "optimized."

We've optimized the operator experience, making the machine safer and more comfortable, and incorporating features that make their jobs easier, more consistent and more predictable. We've optimized electronics and connectivity, providing faster and easier access to data and streamlining technology integration. We've optimized machine health, with improved data analytics and new diagnostic capabilities. We've optimized maintenance, with modular features and consolidated components that make service faster and easier.

And we've done it all for one reason: So you can experience optimization in your hauling operation—and boost your bottom line.

CAT[®] 793

THE GOLD
STANDARD
IN COST
PER TON



The Cat 793 Mining Truck is a popular industry workhorse that is the ideal choice for a wide variety of applications. It delivers high availability and hauls more every load, every cycle and every shift when compared to competitive trucks in its size class—burning less fuel in the process.

New and improved features take the 793 to a new level. The operator sits in a state-of-the-art environment designed for efficiency and equipped with features that increase comfort, automate functions, provide real-time information and boost confidence. The 793 also delivers significant improvements in serviceability and reliability, enhanced connectivity and easier technology integration—including autonomous haulage. These improvements—and more—take an already proven truck to the next level of productivity.

OVER 10% MORE FUEL EFFICIENT*

More productivity, lower fuel consumption and industry-leading powertrain efficiency = greater fuel efficiency vs. the competition

UP TO 10% FASTER CYCLE TIMES*

- + Travel at a class-leading speed of 11.7-12.9 kph (7.3-8 mph) on 10% grade
- + Top speed of 60 kph (37 mph)
- + Capable of traveling at a maximum 28% grade loaded

**compared to competitive trucks*

OVER 30% PRODUCTIVITY BOOST WITH AUTONOMY

- + Up to 11% better fuel efficiency compared to staffed trucks
- + Cat MineStar™ Command for hauling is a fully integrated factory offering
- + Proven on sites around the world
- + Near continuous utilization
- + 35% increase in useful tire life



UP TO
6%

MORE PAYLOAD

- + Highest payload for rated gross machine weight (up to 240 tonnes / 265 tons)
- + Max Payload Body option reduces weight more than 3 tonnes (3.3 tons)

LOWERING COST PER TON

With offerings in both electric and mechanical drive and payloads ranging from 139 to 372 tonnes (153 to 410 tons), Caterpillar can offer a truck for every type of mining application. But one thing all the models have in common is the philosophy we follow in their design. Whatever measurement you use for material movement, our goal is to help you optimize that cycle — lowering cost per ton.



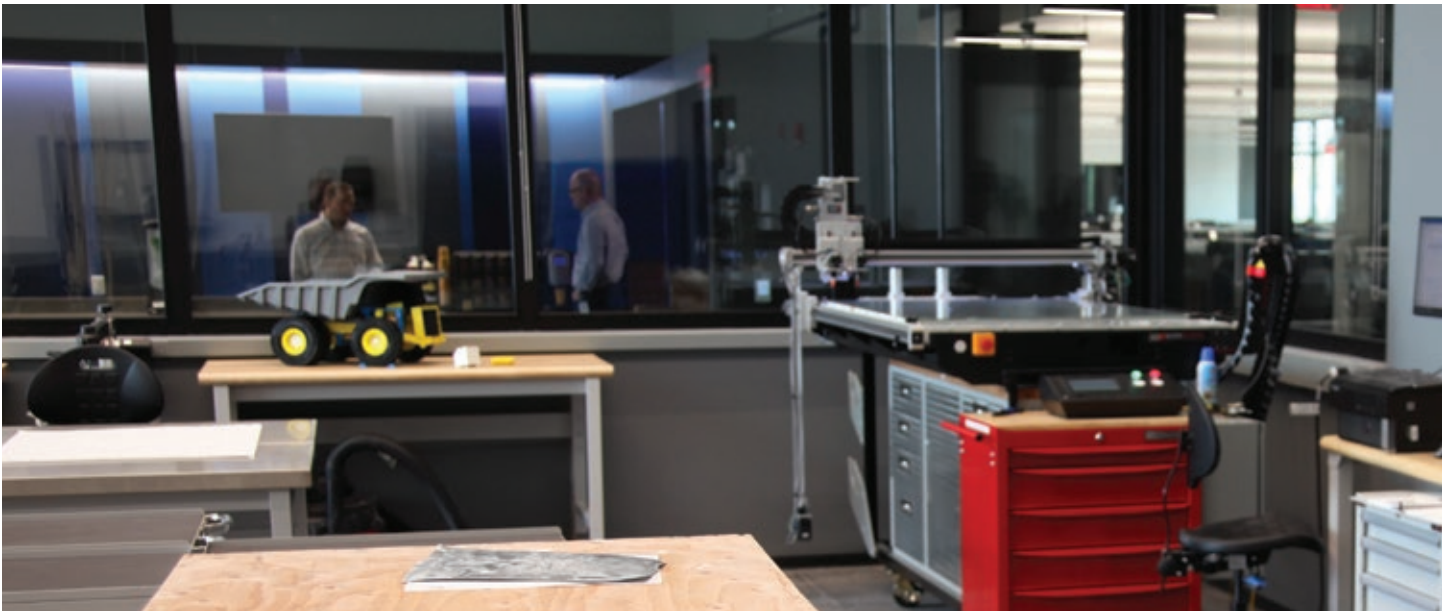

A PROVEN DESIGN PHILOSOPHY

When it comes to making Cat mining trucks, we follow a proven design philosophy that focuses around five main areas:

1. MAKING A SUSTAINED INVESTMENT IN RESEARCH & DEVELOPMENT
2. INTEGRATING EVERY COMPONENT
3. DELIVERING IRON THAT PERFORMS
4. SUPPORTING PRODUCTS— AND PRODUCTIVITY
5. LISTENING TO OUR CUSTOMERS TO SPUR CONTINUOUS IMPROVEMENT

By following this philosophy — for every truck, every time — we strive to ensure that you get what you expect from Caterpillar: low cost per ton, high productivity and more uptime.

A PROVEN APPROACH TO R&D



A WORLD-CLASS TEAM OF ENGINEERS AND EXPERTS



A DISCIPLINED APPROACH TO DEVELOPMENT



MINING INDUSTRY FEEDBACK



TESTING AND VALIDATION OF EVERY MACHINE



HAUL MORE — EVERY LOAD AND EVERY CYCLE

OPTIMIZED PAYLOAD

An empty weight advantage of 13-19 tonnes (14-21 tons) over competitive electric drive trucks in its size class ensures you're getting the full payload you expect. The lower the empty machine weight, the higher your payload — up to 6% more in some cases. And when you choose the Max Payload (MP) Body option, you'll reduce weight an additional 3.0-6.0 tonnes (3.3-6.6 tons).

FASTER SPEEDS

The 793 is faster than competitive trucks and delivers optimal speed on steep grades, poor underfoot conditions and haul roads with high rolling resistance. Its C175-16 diesel engine's 16-cylinder, four-stroke design uses long, effective power strokes for optimum efficiency. The APECS transmission and advanced automatic resistor control (ARC) remove the need for the operator to select gears.



OPTIMUM POWER

The Cat six-speed transmission, with the latest APECS controls, is paired with the C175-16 engine to deliver optimum power over a wide range of operating speeds. The lock-up torque converter engages at approximately 8 km/h (5 mph), delivering unsurpassed stall torque for its size class. Cat final drives work as a system with the upper powertrain to deliver maximum power to the ground.

FASTER CYCLES

In addition to faster speeds than competitive trucks, the 793 reduces cycle times thanks to a number of options and features. Automated functions and controls boost efficiency and shorten the operator learning curve. In addition, the Advanced Power Electronic Control Strategy (APECS) delivers productivity and efficiency improvements that can reduce cycle times. Benefits of APECS vary by application, but most mining applications will see an improvement to the bottom line through:

- + **Shorter cycle times.** More continuous torque and rimpull delivers more power to the ground and makes it possible to use a higher gear on grade for optimal fuel efficiency.
- + **Faster acceleration.** Forward momentum and torque are maintained through each shift, with optimum gear selection resulting in faster acceleration.
- + **Improved operator comfort.** Operators enjoy a more comfortable ride thanks to smoother transitional shifting and reduced shift jerk levels.
- + **Reduced haul road maintenance.** Smoother shifting results in less spillage and less haul road maintenance required.
- + **Improved engine and powertrain life.** A reduction in torque spikes and fewer variations in engine speed deliver longer engine and powertrain component life.



A TRUCK YOU CAN DEPEND ON

The Cat 793 has been a reliable performer on mine sites for decades, and today's 793s are achieving more than ever.

The 793 has been improved with longer-life components, extended service intervals and easier maintenance to deliver mechanical availability that is consistently greater than 90%. And today's 793 is built on the durable 240-tonne (265-ton) frame, backed by unprecedented levels of virtual and in-iron validation. Almost 5,000 793 trucks are currently operating with millions of operating hours.

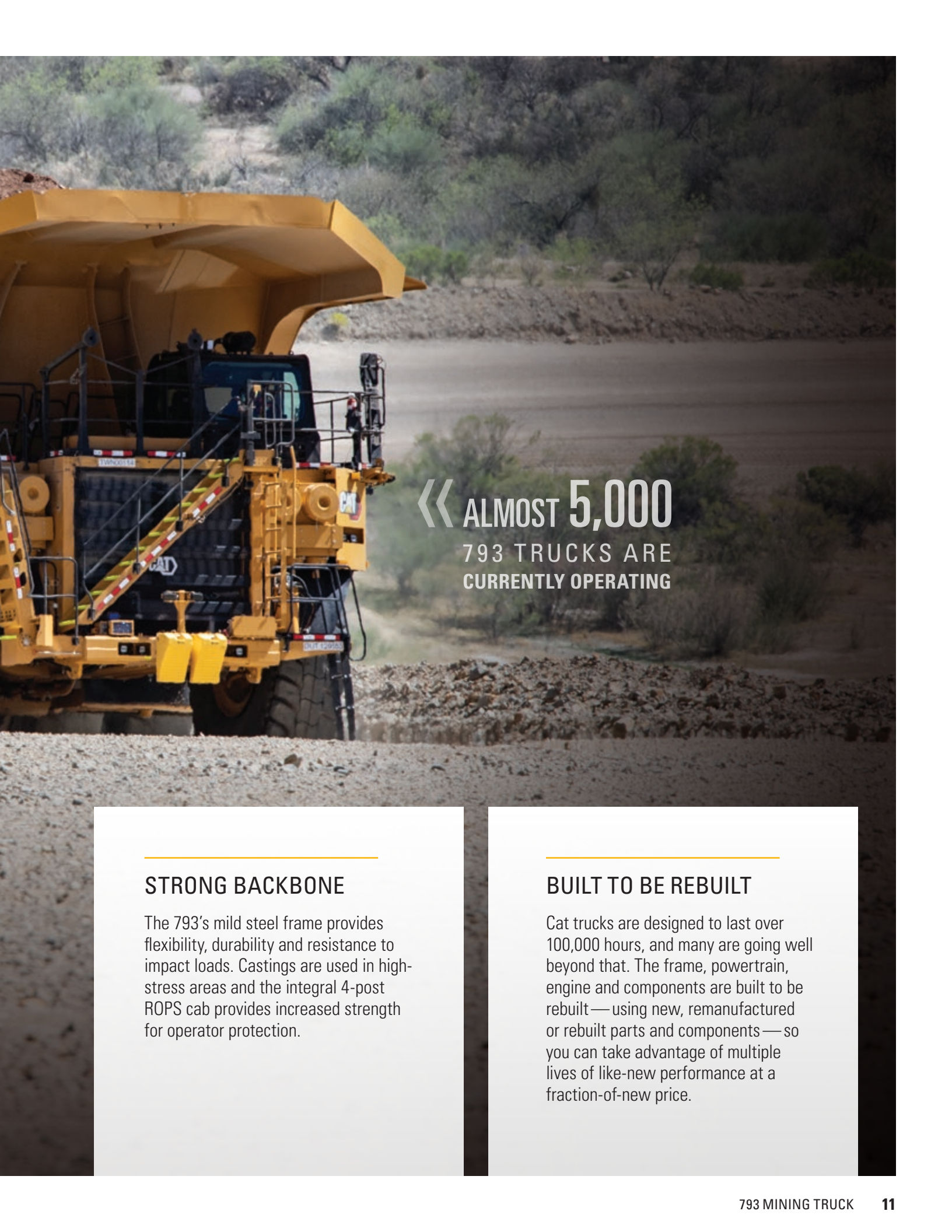

« **ALMOST 5,000**
793 TRUCKS ARE
CURRENTLY OPERATING

STRONG BACKBONE

The 793's mild steel frame provides flexibility, durability and resistance to impact loads. Castings are used in high-stress areas and the integral 4-post ROPS cab provides increased strength for operator protection.

BUILT TO BE REBUILT

Cat trucks are designed to last over 100,000 hours, and many are going well beyond that. The frame, powertrain, engine and components are built to be rebuilt—using new, remanufactured or rebuilt parts and components—so you can take advantage of multiple lives of like-new performance at a fraction-of-new price.



MORE TIME HAULING, LESS TIME SERVICING

The 793 is designed to reduce the time you spend on regular maintenance procedures. Enhanced serviceability and long service intervals help increase machine availability and productivity.



REDUCE YOUR DOWNTIME. REDUCE YOUR COSTS.

We've reduced key contributors to downtime with features like the new modular HVAC (heating, ventilation and air conditioning) system, which improves reliability and consolidates components so the entire system can be removed and replaced quickly. A modular radiator reduces engine removal and installation time and enables rebuilds to be completed off the truck for reduced downtime.

Remote Troubleshooting capabilities reduce downtime and optimize machine performance by providing immediate access to the latest software updates and making it possible to troubleshoot the machine remotely or schedule updates when it's most convenient to the operation.

- + Reduces machine downtime due to software by as much as 50%
- + Helps ensure that machine faults are repaired as soon as possible — decreasing reporting or data quality issues by 10%
- + Decreases the need to pay technicians' travel and mileages expenses

The next generation of productive hauling delivers significant improvements in serviceability and reliability.

- + Optional fast fill service center with Live S•O•SSM Service Center and brake wear indicators
- + Grouped ground-level maintenance and checkpoints
- + 2,000-hour hydraulic filters
- + Oil level sight gauges and front wheel sight glass
- + Service platforms on the engine and transmission
- + Easy access to major components for easy servicing and removal
- + 100% airless electric start option, which eliminates air system maintenance from the machine and improves uptime
- + AutoLube system that automatically lubricates necessary components on a regular basis
- + Sealed electrical connectors

DESIGNED BY OPERATORS FOR OPERATORS

The latest cab is equipped with features that increase comfort and improve efficiency.



+17%
CAB
WIDTH

+11%
LEG
ROOM

34%
MORE
OPERATOR
SPACE

+19%
SHOULDER
ROOM

As compared to D-series cabs

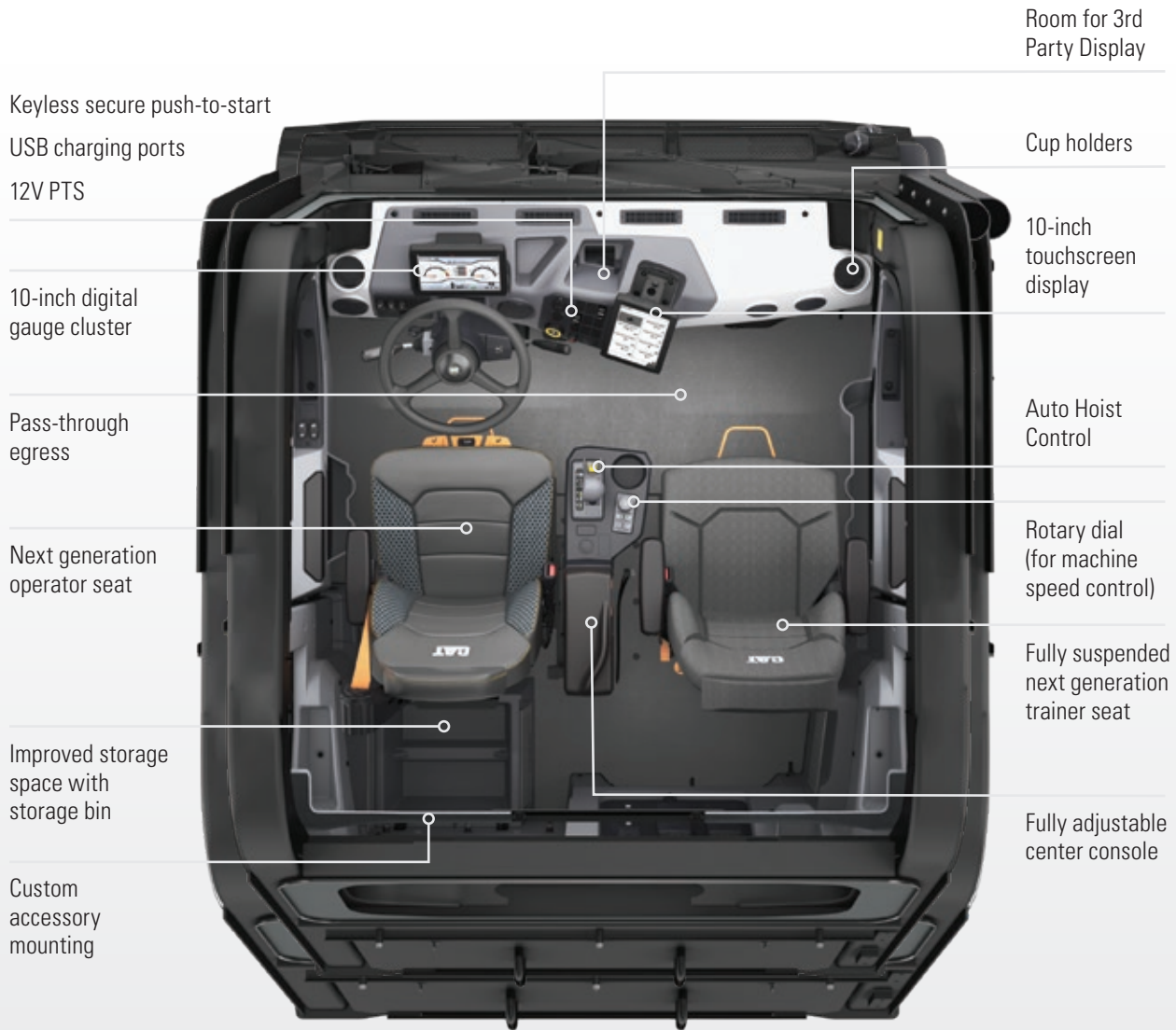

Keyless secure push-to-start

USB charging ports

12V PTS

10-inch digital gauge cluster

Pass-through egress

Next generation operator seat

Improved storage space with storage bin

Custom accessory mounting

Room for 3rd Party Display

Cup holders

10-inch touchscreen display

Auto Hoist Control

Rotary dial (for machine speed control)

Fully suspended next generation trainer seat

Fully adjustable center console

Note: Some optional features shown

IMPROVED CAB

The 793 cab is spacious and ergonomic, with controls, levers and switches positioned for ease of use. It's also quieter and offers automated temperature control and cab filtration for a safer and more comfortable environment. A walk-through cab with fully adjustable center console, easy-to-adjust seat and increased leg room make the cab ideal for operators of all sizes.

The cab can be equipped with High Efficiency Particulate Air (HEPA) filters to cut respirable dust penetration by 96% — reducing operator exposure to potentially hazardous substances such as asbestos and coal dust. The system delivers sustainable positive airflow into the HVAC, enabling cabin pressurization at a stabilized level that is less noticeable to the operator.

COMFORT SEAT

The next generation seat is four-point-restraint ready and improves operator comfort with features like thigh tilt and extensions, air adjustable side and lumbar bolsters, leather upholstery, heated and cooled cushions and dynamic end dampening suspension.



ADVANCED SCREENS

Machine data, controls and guidance information are consolidated onto two 10-inch screens to reduce the number of displays required and present the right information when needed. The screens are ideally located to enable the operator's eyes to remain forward as much

as possible, reducing fatigue and improving safety. The gauge cluster is non-touchscreen while the secondary screen containing machine information is a touchscreen display. The displays provide a simple, consistent and intuitive user interface for operators across all global regions.

BOOSTING OPERATOR PRODUCTIVITY AND BUILDING CONFIDENCE

The next generation of productive hauling starts with the operator, who sits in a state-of-the-art environment designed for efficiency and equipped with features that automate functions. We've made the operator experience easier, safer, more consistent and more predictable. We've increased efficiency through automation, improved access to information and reduced fatigue. We've also added features that improve machine responsiveness and controllability while improving cycle times.

30+ NEW OR IMPROVED TECHNOLOGY FEATURES



AUTO HOIST

The optional Auto Hoist feature automatically raises the body and controls engine speed, simplifying operation and minimizing cycle times and cycle time variations across various operators. This feature is integrated with the transmission control, requiring less hand movement and enabling easier operation.



OPERATOR SPEED COACHING

The Operator Speed Coaching function gives operators real-time feedback on factors such as payload, grade and ground conditions to help them choose the right speed for maximum productivity and safety.



PAYLOAD MONITORING

The payload monitoring system is twice as accurate as its predecessor, with better monitoring and an improved interface that provides easy access to information.

ENHANCED VISIBILITY AND AWARENESS

The integrated Cat MineStar™ Detect Object Detection system combines radar and cameras to warn operators about light vehicles or stationary hazards around the machine. In addition, an optional 360 Surround View camera delivers a bird's-eye perspective, increasing visibility and improving awareness. Together, these two systems give operators a complete picture on a single screen.



DYNAMIC STABILITY CONTROL (DSC)

An option to help steer operators in the right direction, DSC monitors steering intention — where the operator intends to go — tracks the motion of the truck, and then automatically modulates the brakes to ensure the machine is tracking.

- + Prevents understeering & oversteering
- + Gives operators better control of their machines
- + Ensures a safer mine for everyone

MACHINE SPEED LIMITING AND CRUISE CONTROL

This feature allows the operator to quickly and easily set a target speed limit. The truck will limit fuel or apply brakes to ensure the target speed limit is not exceeded. The powertrain will select the appropriate gear and RPM to maximize performance and efficiency.

NOTE: Some optional features shown

AUTOMATIC RESISTOR CONTROL (ARC)

Automatic Resistor Control senses truck conditions like grade, payload, brake oil temperature and more to automatically set an optimum resistive braking speed. This allows trucks to travel 3–6% faster on grade, driving down cycle times with no impact on safety. In addition, zero fuel is consumed during mechanical resistive braking.

HILL START ASSIST WITH ANTI-ROLLBACK

Hill Start Assist uses physical grade and payload to determine the rimpull needed to keep the truck stationary and simplifies operation to move the truck in the selected direction.

Anti-Rollback stops the machine with automatic brake application when it is rolling in the opposite direction of the selected gear.

ANTI-LOCK BRAKE SYSTEM (ABS)

This optional system reduces wheel lock and the resulting chance of an uncontrollable skid, making it easier to control the truck in braking situations with reduced traction. ABS allows the operator to steer while in a sliding condition and helps the operator maintain the desired path of travel during braking.

ENHANCED TRACTION CONTROL

The Enhanced Tractional Control feature monitors front and rear wheel speeds, grade and machine acceleration to determine targeted rear wheel speeds, then uses that information to control rear corner brakes and limit engine torque when needed to deliver improved traction for the truck. The feature increases traction control responsiveness and improves machine controllability and reduces tire wear and damage.



SAFETY-INFUSED

From slip-resistant surfaces and guard rails to state-of-the-art collision avoidance technologies, the Cat 793 is infused with features to help operators feel safe and confident on the job.

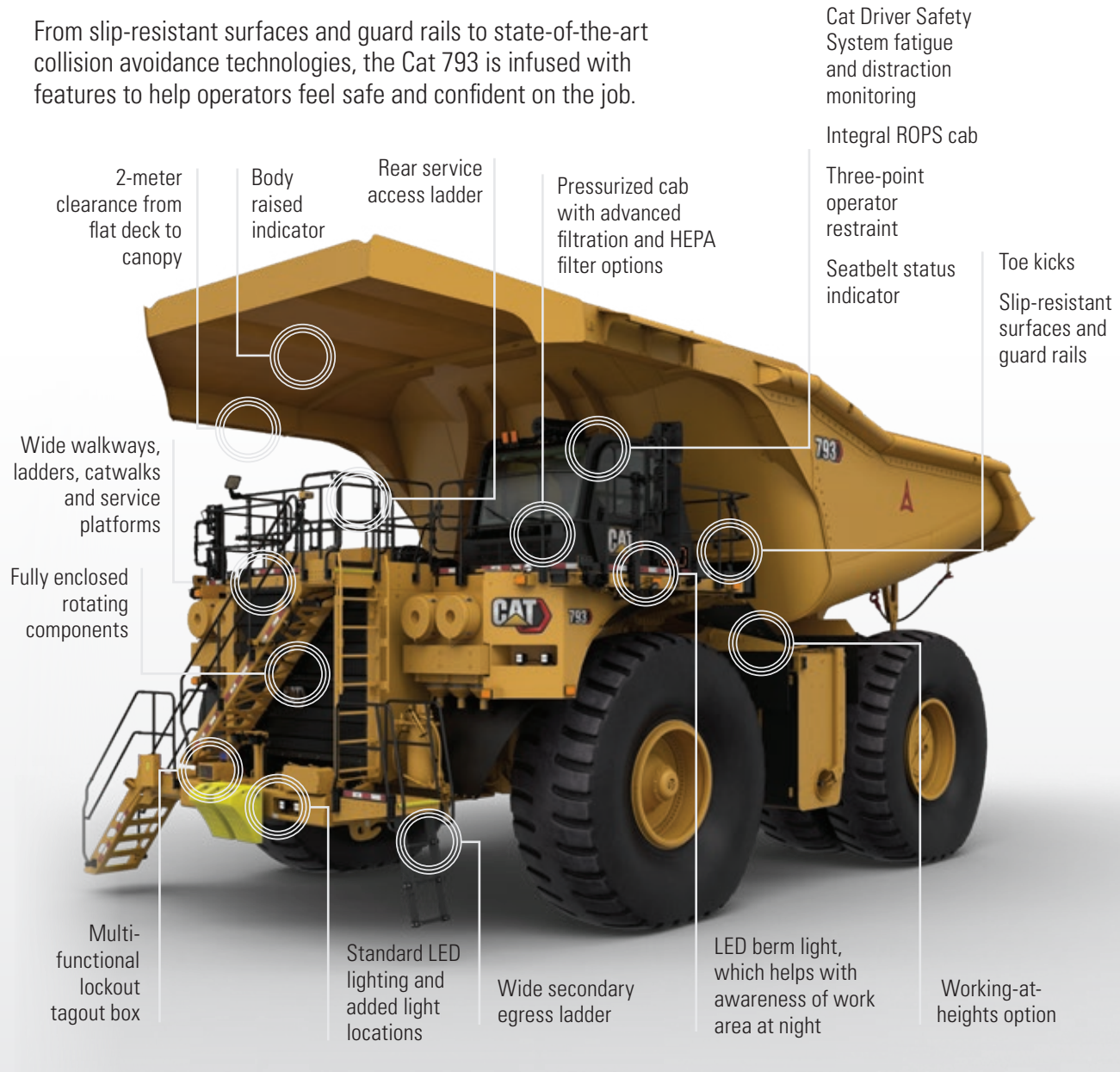

SUPERIOR BRAKING

The 793 features Caterpillar's patented oil-cooled, multiple disc brakes — the most respected and trusted in the industry. They provide immediate, fade-resistant braking for increased operator confidence. The 793 has a true four-corner service braking and mechanical resistive braking (retarding) system proven in thousands of Cat mining trucks under every conceivable condition. With mechanical resistive braking power applied to all four corners, the full weight of the truck can be applied for traction, resulting in maximum productivity even in poor underfoot conditions. The Caterpillar braking system delivers anti-lock braking and dynamic stability control.

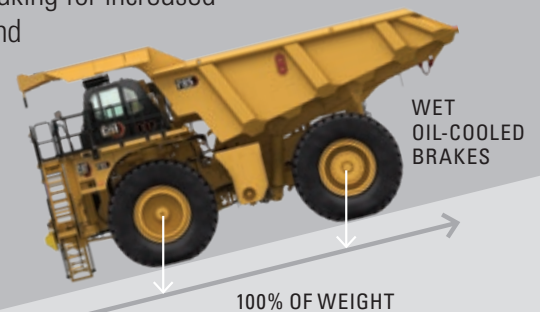



CUTTING-EDGE CONNECTIVITY

Next generation connectivity delivers:

- + Faster data transfers
- + Instant access to quality information on any supported device
- + Consistent data communication
- + More insightful and actionable data
- + Improved data analytics
- + New diagnostic capabilities

Improved connectivity has a positive impact on every aspect of a mining operation — from operator performance to equipment maintenance, fleet management to machine life.

We've developed a future-proof platform that makes it easier to integrate technologies that provide data and analytics, keep operators and sites informed, and boost the overall performance of your entire operation. Improved access to quality data and real-time information gives you the ability to make better decisions, faster.

Connectivity is supported by ethernet communication across the machine controllers, sensors that are optimized for data analytics, and robust controls. Advanced connectivity on the new 793 truck is enabled by standard cellular 4G/LTE, optional dual mode 4G/LTE and Satellite Product Link™, or locally installed Wi-Fi.

PRODUCT LINK™ ELITE

Product Link Elite is Caterpillar's next generation on-board hardware that enables your assets to collect and transmit information into locally-hosted or cloud-hosted applications. Its easy-to-configure interface and customizable data-push frequency enable equipment management anywhere, anytime. Every machine from factory comes standard with Product Link cellular connectivity as well as an option to communicate through dual-mode cellular 4G/LTE and satellite, or local Wi-Fi networks.

Product Link Elite transmits information off the equipment via cellular, satellite or mine network connection and can also be configured for direct connectivity to the cloud. The hardware delivers fast processing with enhanced on-board memory and storage capability and offers on-board data buffering for intermittent network connections

BUMPER-TO-BUMPER CATERPILLAR

The individual components, software, systems and engine that go inside a Cat 793 have different purposes, but they have one very important thing in common: They are all manufactured by Caterpillar and supported by the Cat dealer network. This integration ensures that the entire truck, from tires to transmissions, engines to electronics, can be fully optimized to deliver the lower cost per ton.





GET THE RIGHT BODY FOR THE JOB

Matching the truck body to the application is a critical part of achieving the best value from your 793. It's essential that the body is integrated with the whole machine. Only Caterpillar can provide comprehensive virtual validation of how the body and chassis interact.

Caterpillar offers the widest variety of OEM designed, application-specific truck body solutions in the industry. Cat bodies consistently meet target payload and outperform competitive bodies in scale studies. They are designed and analyzed as an integral part of the entire vehicle system, helping to ensure you achieve maximum chassis life. From the design to the materials, manufacturing to shipping, the entire process meets Cat standards of quality and control.

BODY OPTIONS

The 793 has the widest variety of body options compared to all other models and operates in the widest variety of applications globally.



MAX PAYLOAD (MP) BODY

The MP body is a lightweight, bolster-less design utilizing formed base plates in place of traditional structural members. It employs a convex canopy and a strong perimeter reinforcement in the top rail and rear rib. Curved front/side transitions minimize carryback. Material flow is improved with a two-stage kick-up in the tail that creates a smoother angular transition as the material exits the body while still minimizing spillage and providing designed-in freeboard at the tail. A modular concept allows for a sideboard attachment to increase volume, or dedicated base body sidewall adjustments are available from the factory.

THE BENEFITS

- + Increased payload
- + Reduced fuel consumption
- + Extended tire life
- + Front wheel life
- + Less spillage
- + Minimized carryback
- + Improved maintenance access



OVER 3,400
793 BODIES SOLD
— SINCE 2008 —

HIGH PERFORMANCE (HP) BODY

The HP body features a lightweight, simplified and durable design that provides complete front machine coverage and extended overhead protection.

The HP body features robust top rail geometry with internal stiffeners and a high-visibility load placement indicator. Patented floating bolsters and spring plates improve overall durability by avoiding welds in high-stress areas. In addition, the body requires only minimal liner coverage due to thicker and harder base plates. Curved front / side transitions minimize carryback.

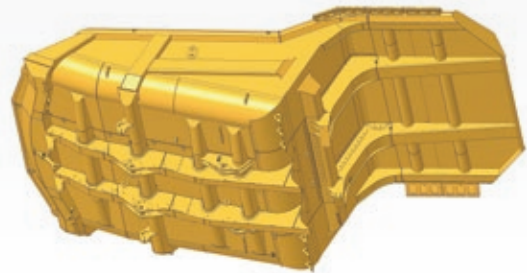

TRADITIONAL BODY OPTIONS

In addition to the MP and HP body, the 793 can be configured with our traditional body options, which are also specifically designed to work with the Cat frame for superior structural performance. Bodies can also be customized with options like tail extensions, sideboards and application-specific liners, which help to maintain rated payload, reduce spillage and improve hauling efficiencies.

COAL BODY

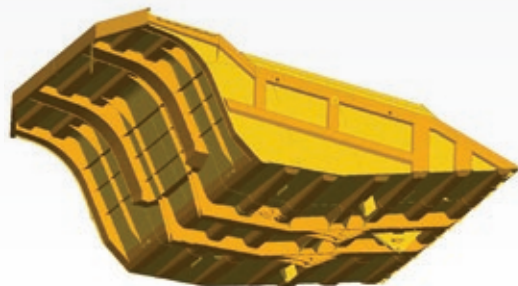



BUILT FOR THE FUTURE

Like all next generation trucks, the Cat 793 is built for the future. Designed for future updates, the 793 features an expandable platform and architecture and leaves the factory ready for full integration of standard and optional technologies. The engineering group responsible for the family of controllers on the base truck is also responsible for the software that controls the trucks. This results in consistency and portability.

- + Ability to deliver new solutions and technology within the existing architecture
- + Easier to integrate Caterpillar and certain third-party current and future technology solutions
- + Plenty of processing power and high-speed communication enable delivery of future features
- + Intentionally designed for more information and data than just machine controls

OPTIMIZE YOUR ENTIRE OPERATION

Optional offerings improve the overall safety, efficiency and productivity of your operation:

- + Fleet Management
- + Driver Safety System
- + Proximity Awareness
- + Equipment Care Advisor
- + Health—Equipment Insights
- + Health Office
- + Command



GAIN AN EDGE WITH CAT MINESTAR™ SOLUTIONS



FLEET



TERRAIN



DETECT



HEALTH



COMMAND

Cat MineStar Solutions help you optimize your loading and hauling operation, keeping your shovels busy and your trucks on the move. MineStar fleet management tools will help you identify opportunities to improve truck efficiencies in ways that maximize payload, reduce cycle times, lower costs and boost profitability. And they'll guide your operators to the right material, optimize every truck load, track what material goes where and ensure you're moving the right amount of material with every load. And when you add autonomous trucks to the mix, you'll gain even more efficiencies. The result? Productivity goes up and costs go down.

MineStar Solutions for loading and hauling include a range of capabilities that meet the needs of your fleet, your budget and your site. From simple fleet management offerings to fully autonomous haulage, every solution puts more value to your bottom line.

MANAGING AND MITIGATING FATIGUE

Fatigued and distracted machine operators are present on every mine site every day—and the consequences can be costly, even fatal. The Cat Driver Safety System (DSS) is a non-intrusive, in-cab detection system that can help you identify fatigue and distraction—and address it—in real time. The 793 leaves the factory ready for the DSS, which also includes an option to send events to a 24-hour monitoring center.



IMPLEMENTING AUTONOMOUS HAULAGE

MineStar Command for hauling, an autonomous hauling solution, is a fully integrated factory offering on the 793. Command enables near-continuous utilization and has proven to increase productivity by up to 30%.

Operators are completely removed from the environment for significant improvements in site safety. Hundreds of autonomous 793s are currently in service.

MINING — FOR A — BETTER WORLD

When it comes to your hauling operation, Caterpillar and Cat dealers are here to help you achieve your climate-related objectives. With many solutions available today — and many more on the horizon — we're committed to working together to find new ways to mine more responsibly and build a better, more sustainable world.

SOLUTIONS FOR YOUR JOURNEY TO A REDUCED-EMISSIONS FUTURE

There are a variety of features, solutions and offerings that can help you reduce emissions today as you build a path to a reduced-emissions future.

- + Today's 793 has been designed to use less fuel and reduces corresponding greenhouse gas emissions. Zero fuel burn during mechanical resistive braking, combined with high mechanical drive powertrain efficiencies, can decrease fuel consumption.
- + The optional U.S. EPA Tier 4 Final engine can reduce NOx and particulate matter.
- + Caterpillar scale studies utilize truck scales and bed scanners to help optimize empty machine weight, reduce carryback and ensure maximum payload. Reduction in weight or payload results in lower CO2 per ton.
- + Caterpillar Production Studies optimize operations and maximize productivity and utilization at the fleet, site and enterprise levels. These studies can be conducted on site or remotely.
- + Site assessments that evaluate haul road design, maintenance and traffic patterns provide opportunities to improve cycle times, increase productivity, lower fuel burn per cycle and reduce maintenance costs.
- + The 793 engine is compatible with diesel fuel blended with lower-carbon intensity fuels such as biofuels and renewable fuels. These fuels reduce lifecycle greenhouse gas (GHG) emissions in the fuel value chain; GHG emissions at the tailpipe are essentially the same as traditional fuels. Drop-in replacements for diesel include biodiesel fuels, Hydrotreated Vegetable Oil (HVO) and Gas-to-Liquid (GTL) fuels.
- + Features like the Enhanced Engine Oil Filtration System, continuous rear axle filtration, extended life filters and longer maintenance intervals decrease the amount of waste contributed to the environment.
- + We preserve raw materials, conserve energy and reduce emissions through the Cat Reman program, which returns end-of-life components to like-new condition. Reman has been shown to contribute 65-87% less GHG process emissions. It uses 80-90% less new materials (by weight) and 65-87% less process energy.*
- + Machine rebuilds also consume less energy and reduce emissions compared to manufacturing new trucks.

**Represents U.S. environmental impacts comparing gate-to-gate remanufacturing and manufacturing processes for engines and components. Based on 2018 external study of Cat engines, alternators and turbochargers. Does not include impacts elsewhere in our value chain.*

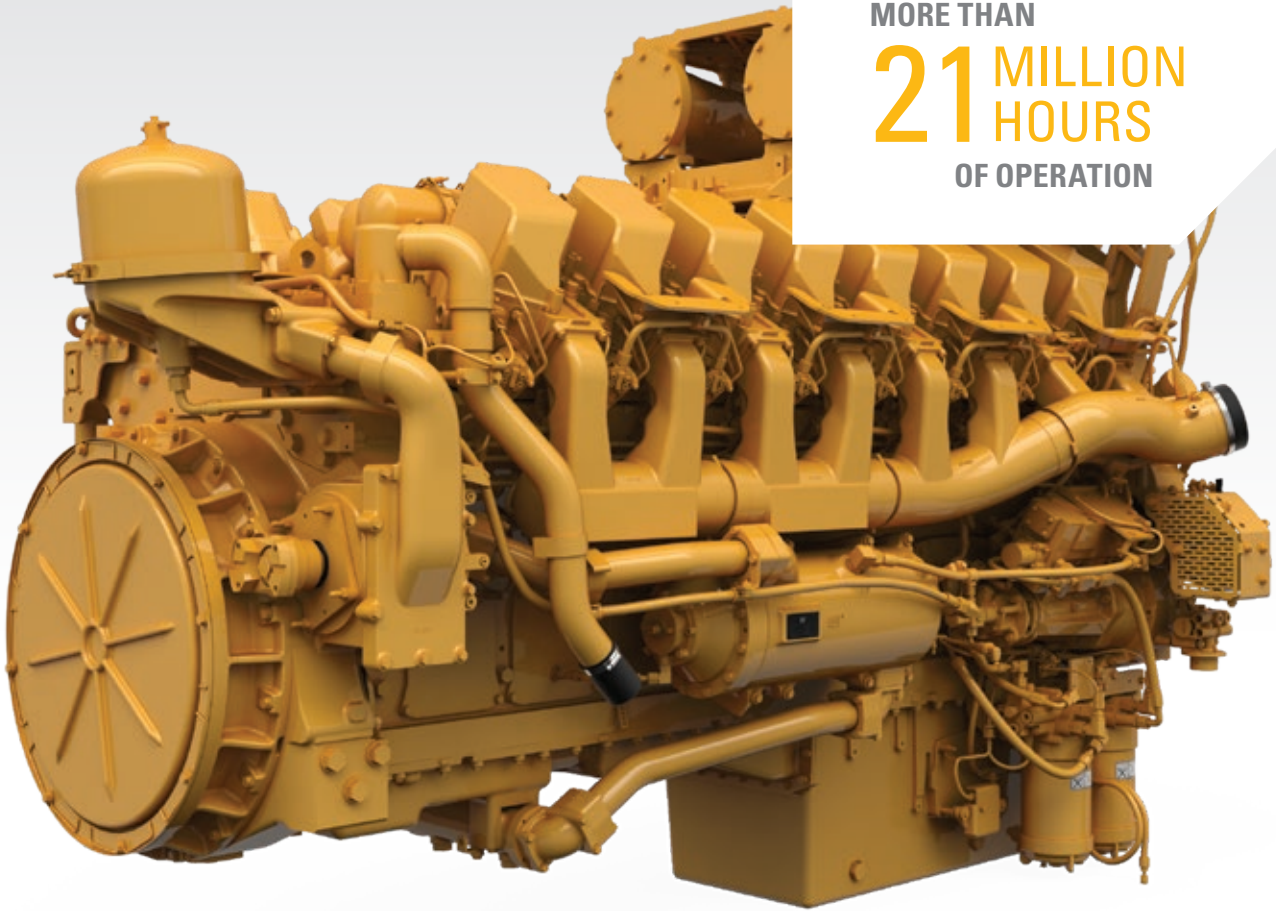

MORE THAN
21 MILLION
HOURS
OF OPERATION

MORE POWER, LOWER COSTS

The 793 is powered by the proven C175-16 engine. This engine has more than 21 million hours of operation and in the 793 is capable of burning over 4.5 million liters (1.2 million gallons) of fuel before overhaul. The C175 reduces fuel consumption while increasing horsepower. Engine power is adjustable to adapt to changes in production targets and to work smoothly in mixed fleets.

The engine contributes to overall lower operating and maintenance costs thanks to:

- + High displacement, low rpm rating and conservative horsepower ratings, which mean more time on the haul roads and less time in the shop.
- + The Cat Common Rail Fuel System provides optimal fuel delivery, which reduces both fuel consumption and emissions output.
- + The new Cat Enhanced Engine Oil Filtration System increases engine life, eliminates cartridge filter changes and makes it possible to extend oil change intervals.



SUPPORTING PRODUCTS

—AND PRODUCTIVITY

Our commitment to your success doesn't end when your Cat 793 begins hauling overburden or ore. We immediately start looking for ways to make that truck work more efficiently, safely and productively. From addressing performance issues, to training operators and technicians, to calibrating onboard technologies — our support of your truck productivity is ongoing.

Caterpillar and Cat dealer personnel will work with you to help improve the performance not only of your trucks but of your overall loading and hauling operation. You'll have access to parts and service, and technicians who are focused on helping you optimize repairs to keep machines in the field rather than the maintenance shop. And we help with training to ensure your operators have the skills and knowledge they need to work as efficiently and productively as possible.

Together with our Cat dealer network, we customize service offerings to provide a maintenance solution that fits your operation — whether you want to perform the majority of service yourself, or you're looking for an on-site expert to manage your maintenance organization. We're also consultants who can help you make smart decisions about buying, operating, maintaining, repairing, rebuilding and replacing equipment.

SITE-LEVEL SOLUTIONS

We're committed to supporting more than your equipment. We work together to find ways to help you optimize your entire operation. We'll work alongside you to help you improve site productivity and machine availability while lowering cost per ton. We have teams of people with decades of experience working in the industry. They have hands-on knowledge of mining machines and applications, site operations and equipment maintenance and repair, mining technologies, safety solutions, fleet management—and more

- + Cat Job Site Solutions—Combining the products, services and expertise of the global Cat dealer network and Caterpillar providers into customized solutions that help you optimize your equipment, your people and your overall operation.
- + Caterpillar Safety Services—Guiding you along your safety journey by providing industry best practices, continuous improvement processes and the latest technologies to see, mitigate and manage risks.

CAT CUSTOMER VALUE AGREEMENTS (CVAS)

Cat Customer Value Agreements (CVAs) for mining help you maximize equipment health, keep your fleet moving and get the most from your investment. With built-in cost controls and a range of guarantees, your dealer can tailor these plans to suit your mine site's needs and bring top results to your business. Your Cat dealer can offer you options for planned maintenance, components and powertrain—all with the flexibility to be shaped for your operation.

- + Hassle-Free Ownership. CVAs bring together dealer advice, easy parts acquisition, plus options for flexible payment terms.
- + Hassle-Free Maintenance. Getting the right Genuine Cat Parts delivered to the right place at the right time makes it easier for maintenance to get done. Service options are flexible to meet your needs.
- + Security of Expert Dealer Support. Cat CVAs are customized plans that offer troubleshooting, diagnostics and repairs with Genuine Cat Parts. If you need trained technician assistance, there are options for that, too.
- + Peace of Mind from Equipment Health Management. You get easy access to monitoring tools with a Cat CVA. Digital tools give you the ability to access important operating parameters for your business anywhere you have an internet connection.

SUPPORT FOR THE COMPLETE EQUIPMENT LIFECYCLE

No one knows more about how to get the most from a piece of Cat equipment than your local Cat dealer. This one-of-a-kind, on-the-ground support network delivers expert service, integrated solutions, after-sales support, fast and efficient parts fulfillment, world-class rebuild and remanufacturing capabilities, and more.

Cat dealers operate as nearly 150 local businesses—each one fully embedded in and committed to the geographic area it serves. That means you work with people you know, who know your business, and who respond on your timeframe.



BETTER
LOADING
BETTER
HAULING
**BETTER
BOTTOM
LINE**

With a truck for every site or application — no matter the size class or drive system — and a broad lineup of loading tools, Caterpillar delivers a complete loading and hauling solution that delivers the lowest cost per ton.

Trucks and loaders are ideally matched to optimize the loading and hauling cycle. Whether you choose a Cat electric rope shovel, hydraulic mining shovel or large wheel loader, or a mechanical drive or electric drive Cat truck, you'll find they all have one thing in common: They're Caterpillar, inside and out. From iron to engines, hydraulics to electronics, software to hardware, transmissions to ground engaging tools — systems are fully integrated and work together to deliver optimized performance and a better bottom line.



793

PASS MATCH

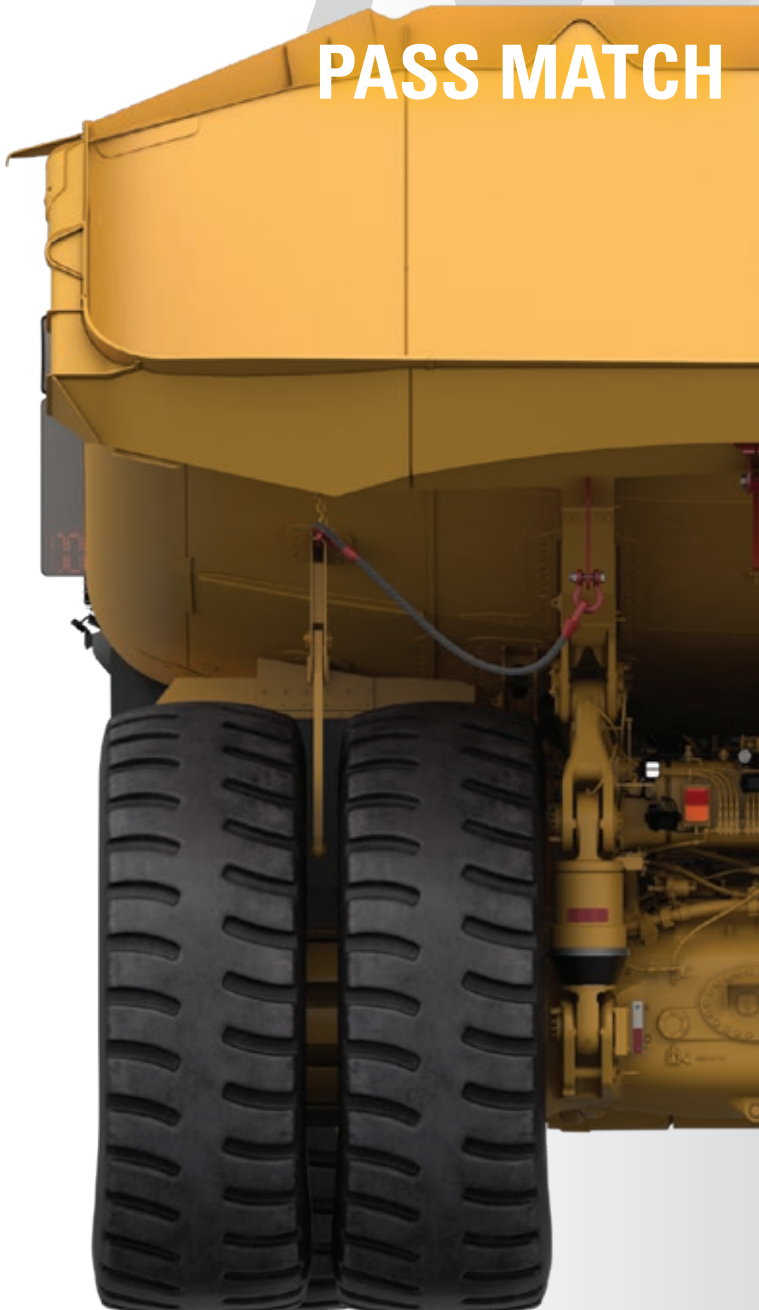

LWL 995 Highlift



5

HMS 6040



6

6060



4

ERS 7295



4

7395 HR



4

7495 HD



3

TECHNICAL SPECIFICATIONS

See cat.com for complete specifications.

ENGINE		
Engine Model	Cat® C175-16	
Gross Power - SAE J1995:2014		
Standard	1976 kW	2,650 hp
Optional	1693 kW	2,270 hp
Net Power - SAE J1349:2011	1886 kW	2,529 hp
Rated Speed	1,750 rpm	
Emissions Rating	Fuel Optimized / U.S. EPA Tier 4 Final / EU Stage V	
Bore	175 mm	6.9 in
Stroke	220 mm	8.7 in
Displacement	85 L	5,187 in ³
+ Net Power advertised is the power available at the flywheel when the engine is equipped with air intake system, exhaust system, and alternator.		
+ U.S. EPA Tier 4 Final / EU Stage V available for applicable markets.		

WEIGHTS – APPROXIMATE		
Rated Gross Machine Weight (RGMW)		
Standard Wheel Stations	386 008 kg	851,000 lb
Extended Life Wheel Stations	404 000 kg	890,668 lb
Chassis Weight (CW)		
Standard Wheel Stations	124 127 kg	273,654 lb
Extended Life Wheel Stations	132 007 kg	291,026 lb
Body Weight (BW)	32 072 kg	70,707 lb
Nominal Rated Payload (NRP)		
Standard Wheel Stations	230 tonnes	253 tons
Extended Life Wheel Stations	240 tonnes	265 tons
+ Consult your tire manufacturer for maximum tire load		
+ Chassis weight with full fuel and fluids, standard & mandatory attachments, hoist, body mounting group, rims, and tires.		

WEIGHT DISTRIBUTIONS – APPROXIMATE	
Front Axle – Empty	51%
Rear Axle – Empty	49%
Front Axle – Loaded	33%
Rear Axle – Loaded	67%
+ Weight distributions optimized with Cat body.	

FINAL DRIVES	
Double reduction, planetary with full floating axles.	
Differential Ratio	1.8:1
Planetary Ratio	16:1
Total Reduction Ratio	28.8

TRANSMISSION		
Forward 1	12.3 km/h	7.6 mph
Forward 2	16.6 km/h	10.3 mph
Forward 3	22.7 km/h	14.1 mph
Forward 4	30.6 km/h	19.0 mph
Forward 5	41.5 km/h	25.8 mph
Forward 6	60.5 km/h	37.6 mph
Reverse	11.4 km/h	7.1 mph
Top Speed – Loaded	60.5 km/h	37.6 mph

TIRES & RIMS	
40.00 R57 (Standard - Standard Wheel Stations)	
46/90 R57 (Standard - Extended Life Wheel Stations)	
50/80 R57 (Optional)	
737 mm (29 in) optional rims, 813 mm (32 in) Optional rims	
+ Quick Change Rims optional.	
+ Extended life wheel stations optional.	
+ Caterpillar recommends the customer evaluate all job conditions and consult tire manufacturer for proper tire selection and TKPH (TMPH) capabilities.	

BRAKING SYSTEM		
Service Brakes:		
Four-Corner, Wet Disc, Oil Cooled, Hydraulically Actuated		
Front Wet Disc Brake Surface Area		
Standard Wheel Station	89 727 cm ²	13,907 in ²
Extended Life Wheel Stations	134 665 cm ²	20,873 in ²
Rear Wet Disc Brake Surface Area		
Standard Wheel Station	134 590 cm ²	20,861 in ²
Extended Life Wheel Stations	155 383 cm ²	24,084 in ²
Standards (Service and Secondary)	ISO 3450:2011	
Parking Brake:		
Four-corner, Multi-disk, Spring applied, Hydraulically Released		

CAPACITY – HP BODY - 100% FILL FACTOR

Struck	112.6-151 m ³	147-197.5 yd ³
Heaped (SAE 2:1)	162-190 m ³	212-249 yd ²

+ Consult your local Cat dealer for body recommendations.

BODY HOISTS

Twin, two-stage hydraulic cylinders with snubbing valve
(Times include advanced control for end of stroke snubbing)

Pump Flow – High Idle	819 L/min	216 gal/min
Relief Valve Setting – Raise	20 370 kPa	2,955 psi
Body Raise Time – High Idle	22 Seconds	
Body Lower Time – Float	23 Seconds	
Body Power Down – High Idle	20.7 Seconds	

SUSPENSION

Self-contained nitrogen/oil cylinders, pin-to-pin mounting, top & bottom double shear clevis attachments

Effective Cylinder Stroke – Front	292 mm	11.48 in
Effective Cylinder Stroke – Rear	140 mm	5.50 in
Rear Axle Oscillation	+/- 4.9 degrees	

SERVICE REFILL CAPACITIES

Fuel Tank	2839 L	750 gal
Fuel Tank (Optional)	4922 L	1,300 gal
Diesel Exhaust Fluid (DEF) Tank	235 L	62 gal
Cooling System	1074 L	284 gal
Crankcase	350 L	93 gal
Front Wheels, Each (SWS)	30 L	8 gal
Each (XLWS)	56 L	15 gal
Differential & Final Drives	984 L	260 gal
Steering System (Includes Tank)	290 L	77 gal
Brake/Hoist System (Includes Tank)	1315 L	347 gal
Torque Converter/Transmission System (Includes Sump)	209 L	55 gal

CAB

Air Conditioning Ambient Temperature to 50C (122F)	9.3 kW	31,722 BTU/hr
Heater / Defroster Ambient Temperature to -30C (-22F)	10.7 kW	36,510 BTU/hr
Sound level: Operator Sound tested to ISO 6394:2008 and ISO 6396:2008		74 dB(A)
Rollover Protective Structure: ROPS for Operator ROPS for Trainer		ISO 3471:2008 ISO 13459:2012
Falling Objects Protective Structure: FOPS for Operator FOPS for Trainer		ISO 3449:2005 Level II ISO 13459:2012 Level II

STEERING

Steer Angle	30.9 degrees	
Turning Diameter (ISO 7457:1997)	28 m	93 ft
Steering Standards	ISO 5010:2019	



793 MINING TRUCK

For more complete information on Cat products, dealer services and industry solutions, visit us at www.cat.com

AEHQ8437-01

Materials and specifications are subject to change without notice. Featured machines in photos may include additional equipment. See your Cat dealer for available options.

© 2024 Caterpillar. All Rights Reserved. CAT, CATERPILLAR, LET'S DO THE WORK, their respective logos, "Caterpillar Corporate Yellow", the "Power Edge" and Cat "Modern Hex" trade dress as well as corporate and product identity used herein, are trademarks of Caterpillar and may not be used without permission.

